



CY3274

Cypress High Voltage Programmable Powerline Communication Development Kit Guide

Doc. # 001-53598 Rev. *E

Cypress Semiconductor
198 Champion Court
San Jose, CA 95134-1709
Phone (USA): 800.858.1810
Phone (Intl): 408.943.2600
<http://www.cypress.com>

Copyrights

© Cypress Semiconductor Corporation, 2009-2011. The information contained herein is subject to change without notice. Cypress Semiconductor Corporation assumes no responsibility for the use of any circuitry other than circuitry embodied in a Cypress product. Nor does it convey or imply any license under patent or other rights. Cypress products are not warranted nor intended to be used for medical, life support, life saving, critical control or safety applications, unless pursuant to an express written agreement with Cypress. Furthermore, Cypress does not authorize its products for use as critical components in life-support systems where a malfunction or failure may reasonably be expected to result in significant injury to the user. The inclusion of Cypress products in life-support systems application implies that the manufacturer assumes all risk of such use and in doing so indemnifies Cypress against all charges.

Any Source Code (software and/or firmware) is owned by Cypress Semiconductor Corporation (Cypress) and is protected by and subject to worldwide patent protection (United States and foreign), United States copyright laws and international treaty provisions. Cypress hereby grants to licensee a personal, non-exclusive, non-transferable license to copy, use, modify, create derivative works of, and compile the Cypress Source Code and derivative works for the sole purpose of creating custom software and or firmware in support of licensee product to be used only in conjunction with a Cypress integrated circuit as specified in the applicable agreement. Any reproduction, modification, translation, compilation, or representation of this Source Code except as specified above is prohibited without the express written permission of Cypress.

Disclaimer: CYPRESS MAKES NO WARRANTY OF ANY KIND, EXPRESS OR IMPLIED, WITH REGARD TO THIS MATERIAL, INCLUDING, BUT NOT LIMITED TO, THE IMPLIED WARRANTIES OF MERCHANTABILITY AND FITNESS FOR A PARTICULAR PURPOSE. Cypress reserves the right to make changes without further notice to the materials described herein. Cypress does not assume any liability arising out of the application or use of any product or circuit described herein. Cypress does not authorize its products for use as critical components in life-support systems where a malfunction or failure may reasonably be expected to result in significant injury to the user. The inclusion of Cypress' product in a life-support systems application implies that the manufacturer assumes all risk of such use and in doing so indemnifies Cypress against all charges.

Use may be limited by and subject to the applicable Cypress software license agreement.

PSoC® is a registered trademark of Cypress Semiconductor Corporation. All products and company names mentioned in this document may be the trademarks of their respective holders.

Purchase of I2C components from Cypress or one of its sublicensed Associated Companies conveys a license under the Philips I2C Patent Rights to use these components in an I2C system, provided that the system conforms to the I2C Standard Specification as defined by Philips. As from October 1st, 2006 Philips Semiconductors has a new trade name - NXP Semiconductors.

Flash Code Protection

Cypress products meet the specifications contained in their particular Cypress PSoC Data Sheets. Cypress believes that its family of PSoC products is one of the most secure families of its kind on the market today, regardless of how they are used. There may be methods, unknown to Cypress, that can breach the code protection features. Any of these methods, to our knowledge, would be dishonest and possibly illegal. Neither Cypress nor any other semiconductor manufacturer can guarantee the security of their code. Code protection does not mean that we are guaranteeing the product as "unbreakable."

Cypress is willing to work with the customer who is concerned about the integrity of their code. Code protection is constantly evolving. We at Cypress are committed to continuously improving the code protection features of our products.

Contents



1. Introduction	5
1.1 Safety Precautions	5
1.2 Using the PLC Kit	5
1.3 The Cypress PLC Solution	5
1.4 Kit Contents	7
1.5 Additional Learning Resources	8
1.6 Document Revision History	9
1.7 Documentation Conventions	9
2. Getting Started	11
2.1 Kit Installation	11
2.2 PSoC Designer	16
2.3 PSoC Programmer	17
2.4 Software Installation	18
2.4.1 Before You Begin	18
2.4.2 Prerequisites	18
2.4.3 Installing PLC Control Panel Software	18
3. PLC Development Board	21
3.1 Features	21
3.2 CY3274 PLC Development Board Functional Overview	21
3.2.1 Operating Conditions	21
3.3 Hardware Description	22
3.3.1 Development	23
3.3.2 LCD Daughter Card	26
3.3.3 RJ45 Connector for Debugging	27
3.3.4 RS232 COM Port	27
3.3.5 High Voltage with Switched Mode Power Supply (SMPS)	28
3.3.6 Transmit Filter, Transmit Amplifier, and Receive Filter	28
3.3.7 High Voltage Coupling Circuit	29
3.4 Code Example	30
3.5 Technical Reference	30
Appendix	31
Schematics	31
Board Overview	31
User Interface	32
Transmit and Receive Filters and Coupling	33
Power Supply	34
Layout	35
Top Layer	35

Ground Layer.....	36
Power Layer	37
Bottom Layer	38
Top Silkscreen.....	39
Bottom Silkscreen.....	40
Bill of Materials.....	41

1. Introduction



1.1 Safety Precautions



CAUTION: High Voltage (Risk of Electric Shock)

Extreme care is necessary when you work with powerline communication equipment.

Use caution when using power supplies or power related equipment.

- Use the board with expert technical supervision. There is high voltage (110-V, 240-V AC) power on the board.
- Accidental human contact with high voltage is dangerous.
- The capacitors on the board can be energized even after disconnecting the board from the main power supply. Be careful not to touch any parts on the board immediately after you disconnect the main power supply.
- Safety plastic casing is provided on the top of the high voltage section. Do not touch the protected area during live operation for debugging, probing, or for any other purpose.

Cypress bears no responsibility for any consequences that may result from the improper or hazardous use of this board.

1.2 Using the PLC Kit

Cypress's Powerline Communication Solution (PLC) makes it possible to transmit command and control data over high voltage and low voltage powerlines. This solution is developed for low bandwidth powerline communication.

The CY3274 PLC high voltage (HV) PLC development kit provides the capability to develop an application on the Cypress CY8CPLC20 device that can transmit and receive data over high voltage (110 V to 240 V AC) powerlines.

- Chapter 1 provides a brief overview of the Cypress PLC solution. It describes the contents of the CY3274 development kits and lists special features of the kit.
- Chapter 2 gives the functional overview of the PLC board and describes the operating procedure of PLC HV board. It provides a high level hardware description of the board.
- The Appendix contains the schematics, layout, and bill of materials.

1.3 The Cypress PLC Solution

Powerlines are available everywhere in the world. This makes them one of the most widely available communication media. The pervasiveness of powerlines also makes it difficult to predict their characteristics and noise. Because of the variability of powerline quality, implementing robust communication over powerline has been an engineering challenge for years. With this in mind, the Cypress PLC solution is designed to enable secure, reliable, and robust communication over powerlines.

The key features of the Cypress PLC solution are:

- An integrated powerline PHY modem with optimized filters and amplifiers that work with rugged high and low voltage powerlines
- Powerline optimized network protocol that supports bidirectional communication with acknowledgement based signaling and multiple retries
- Support for 8-bit packet CRC and 4-bit header CRC for error detection and data packet retransmission
- Carrier Sense Multiple Access (CSMA) scheme that minimizes collisions between packet transmissions on the powerline

The Cypress PLC solution consists of three key elements as shown in [Figure 1-1](#).

- Powerline network protocol layer
- Physical layer FSK modem
- Power amplification and coupling circuits

Figure 1-1. Cypress PLC Solution Block Diagram

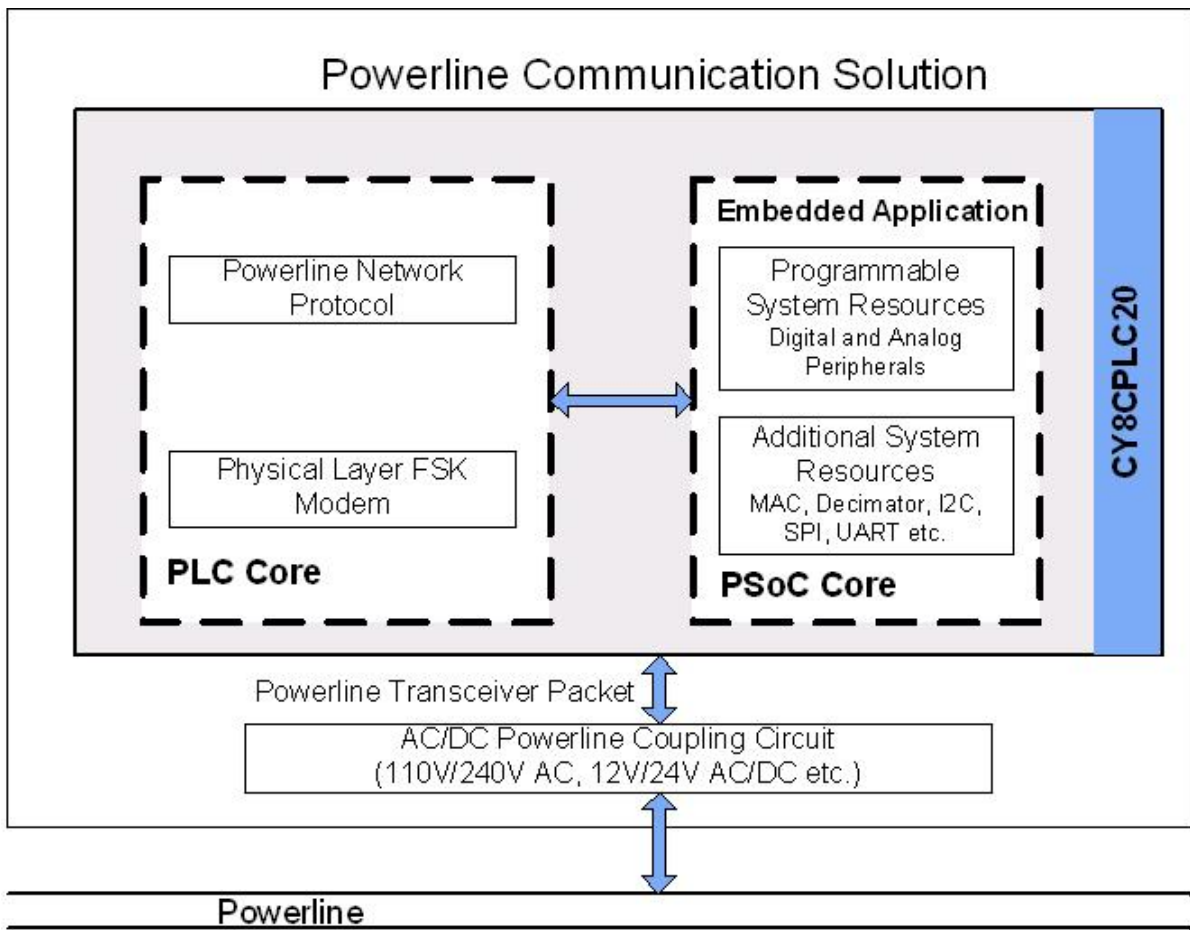

The powerline network protocol layer and the physical layer FSK modem are implemented on the CY8CPLC20 chip. The chip also contains a PSoC core in addition to the PLC core. The CY3274 board contains the CY8CPLC20 device along with the power amplification and coupling circuit for communicating on high voltage (110-240 V AC) powerlines. For a detailed description of the design parameters for the circuit, refer to the application note [Cypress Powerline Communication Board Design Analysis - AN55427](#).

The network protocol layer allows for the addressing of multiple nodes on the network. This enables point-to-multipoint communication. The protocol layer also provides a defined packet structure for transmitting data packets from one node to the other as well as error detection and packet retransmit functionalities. The chip contains a PSoC core in addition to the PLC core. The PSoC core includes configurable blocks of analog and digital logic, and programmable interconnects. This architecture enables you to create customized peripheral configurations that match the requirements of each individual application. A fast CPU, flash program memory, SRAM data memory, and configurable I/Os are also included.

A two-node system level diagram is shown in Figure 1-2. To evaluate this kit, follow the steps in the quick start guide, which is provided in the kit.

Note To evaluate this kit, a second high voltage PLC kit is required. The compatible kits are CY3274 (this kit) and CY3272 High Voltage PLC Evaluation Kit, with EZ-Color. For information on these kits, visit <http://www.cypress.com/go/CY3274> and <http://www.cypress.com/go/CY3272>.

Figure 1-2. PLC System Level Block Diagram – Two Nodes

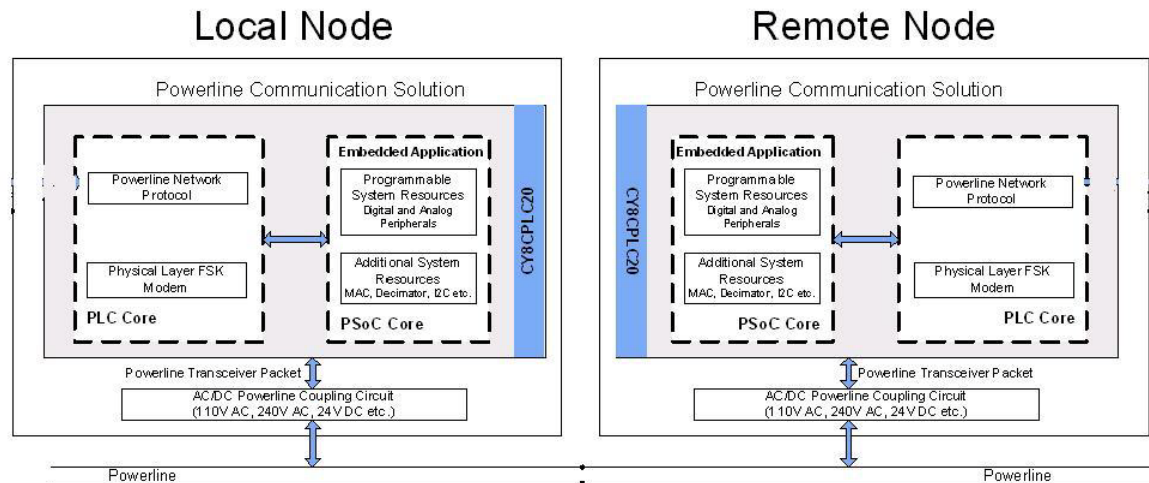

1.4 Kit Contents

The CY3274 PLC HV development kit contains:

- CY3274 quick start guide
- CY3274 PLC HV development board
- CDs containing:
 - Packet test software – PLC Control Panel application
 - PLC Control Panel release notes
 - CY3274 release notes
 - CY8CPLC20 datasheet
 - Development board user guide
 - CY3274 board Altium design project
 - CY3274 board schematics, layout, and BOM
 - Application note – *Using CY8CPLC20 in Powerline Communication (PLC) Applications*
 - PSoC Designer™
 - PSoC Programmer
- AC power cable
- MiniProg1 to program CY8CPLC20
- 25 jumper wires

- LCD module
- USB-I2C bridge
- Retractable USB cable
- Five CY8CPLC20-28PVXI SSOP device samples

1.5 Additional Learning Resources

Visit <http://www.cypress.com/go/plc> for additional learning resources in the form of datasheets, technical reference manuals, and application notes.

- CY3274 Schematic.pdf
<http://www.cypress.com/?rID=38026>
- CY3274 Board Layout.zip
<http://www.cypress.com/?rID=38026>
- CY3274 Kit documentation
<http://www.cypress.com/go/CY3274>
- For a list of PSoC Designer-related trainings, see
<http://www.cypress.com/?rID=40543>
- CY8CPLC20 data sheet
<http://www.cypress.com/?rID=38201>
- For more information regarding PSoC Designer functionality and releases, refer to the user guide and release notes on the PSoC Designer web page:
www.cypress.com/go/psocdesigner
- For more information regarding PSoC Programmer, supported hardware, and COM layer, go to the PSoC Programmer web page:
www.cypress.com/go/psocprogrammer
- AN54416, Using CY8CPLC20 in Powerline Communication (PLC) Applications
<http://www.cypress.com/?rID=37951>

1.6 Document Revision History

Table 1-1. Revision History

Revision	PDF Creation Date	Origin of Change	Description of Change
**	8/14/09	IUS	New kit guide.
*A	9/3/09	IUS	Rework for external release.
*B	12/10/09	RARP	Content updates
*C	09/28/10	RKPM	Added Software Installation, Example Projects, and Technical Reference sections. Added schematic in section 2.3.
*D	03/08/2011	FRE	Added references to the compatible high voltage PLC kits. Added a reference to the quick start guide for evaluation. Added clarifications to the text throughout.
*E	10/12/2011	ADIY	Removed reference to CY3276 and CY8CLED16P01. Updated Figure 1-2. Updated hyperlinks. Updated section 1.5. Added Getting Started section.

1.7 Documentation Conventions

Table 1-2. Document Conventions for Guides

Convention	Usage
Courier New	Displays file locations, user entered text, and source code: C:\...cd\icc\
<i>Italics</i>	Displays file names and reference documentation: Read about the <i>sourcefile.hex</i> file in the <i>PSoC Designer User Guide</i> .
[Bracketed, Bold]	Displays keyboard commands in procedures: [Enter] or [Ctrl] [C]
File > Open	Represents menu paths: File > Open > New Project
Bold	Displays commands, menu paths, and icon names in procedures: Click the File icon and then click Open .
Times New Roman	Displays an equation: $2 + 2 = 4$
Text in gray boxes	Describes cautions or unique functionality of the product.

2. Getting Started



This chapter describes how to install and configure the CY3274-HV PLV Development Kit.

2.1 Kit Installation

To install the kit software, follow these steps:

1. Insert the kit CD into the CD drive of your PC. The CD is designed to auto-run and the **Kit Installer Startup Screen** appears.
2. Click **Install CY3274 High Voltage PLC Kit** to start the installation.

Figure 2-1. Kit Installer Startup Screen



Note If auto-run does not execute, double-click the *cyautorun.exe* file on the root directory of the CD.

Figure 2-2. Root Directory of CD

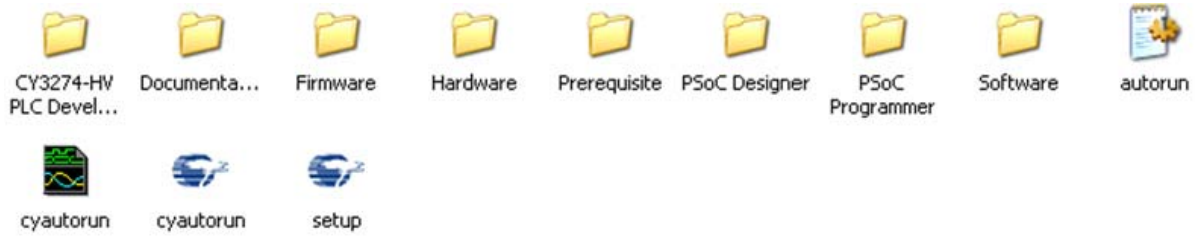

3. The **CY3274-HV PLV Development Kit - InstallShield Wizard** screen appears. Choose the folder location to install the setup files. You can change the location of the folder using **Change**.
4. Click **Next** to launch the kit installer.

Figure 2-3. CY3274-HV PLV Development Kit - InstallShield Wizard

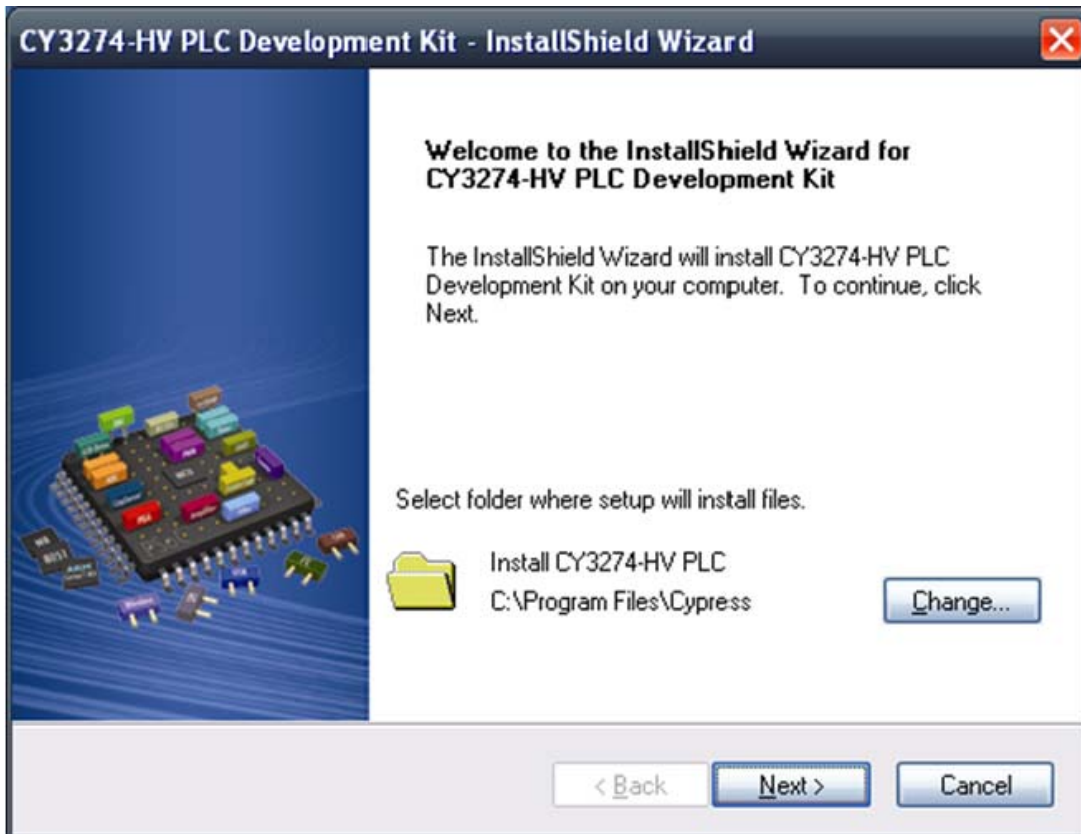

5. On the **Product Installation Overview** screen, select the installation type that best suits your requirement. The drop-down menu has the options **Typical**, **Complete**, and **Custom**, as shown in Figure 2-4.
6. Click **Next** to start the installation.

Figure 2-4. Installation Type Options



7. When the installation begins, a list of all packages appears on the **Installation Page**.
8. A green check mark appears next to every package that is downloaded and installed.
9. Wait until all the packages are downloaded and installed successfully.

Figure 2-5. Installation Page

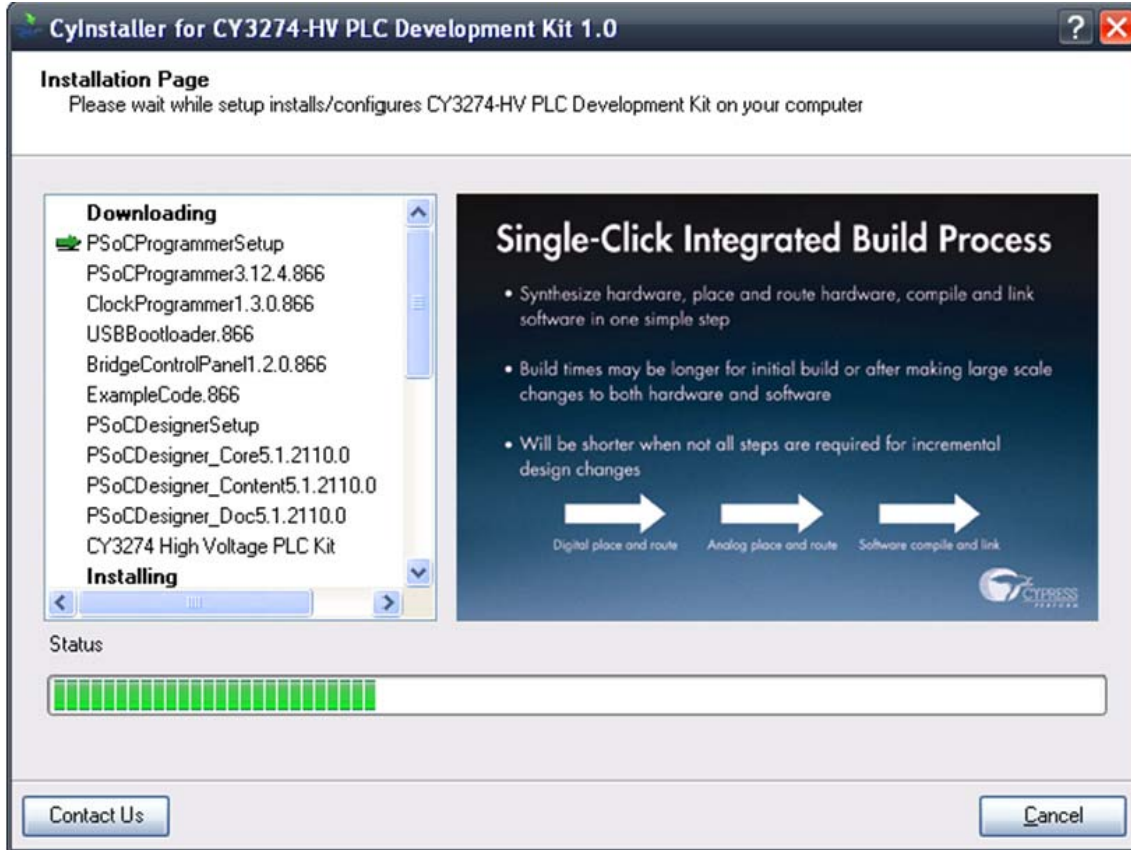

10. Click **Finish** to complete the installation.

Figure 2-6. Installation Completion Page

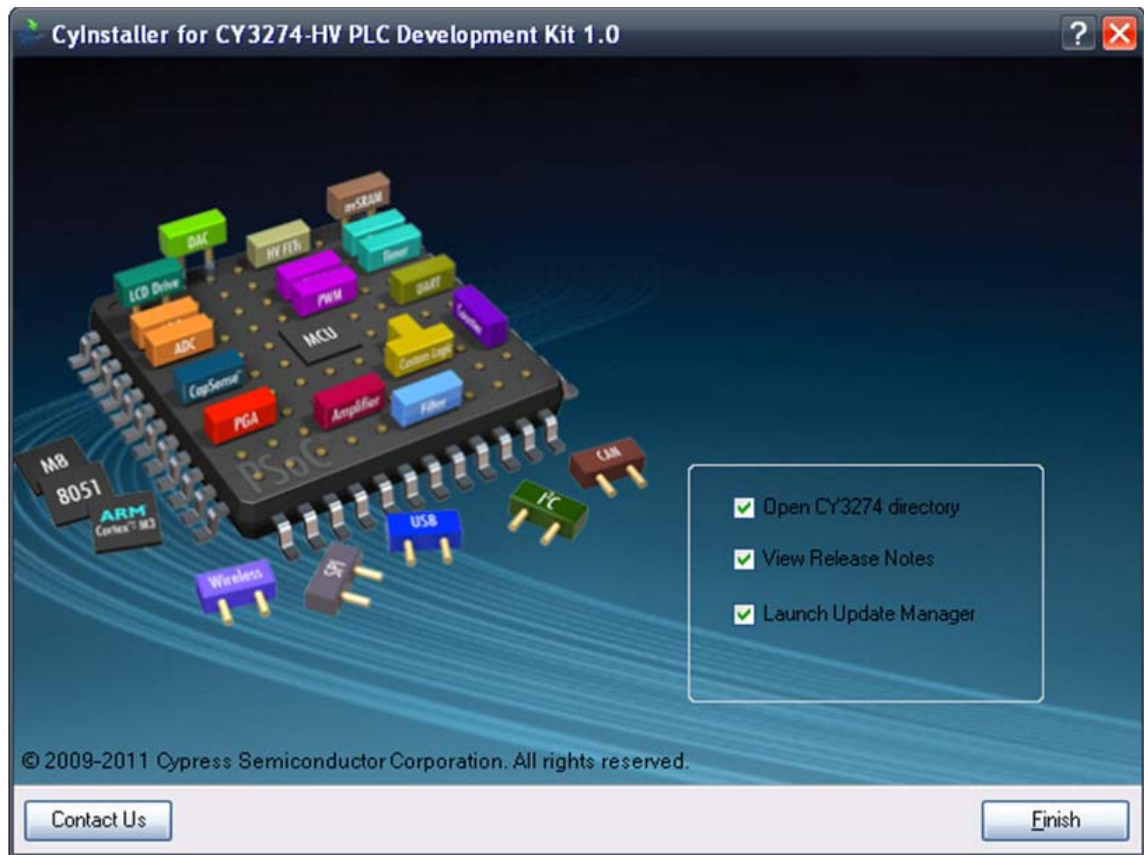

2.2 PSoC Designer

1. Click **Start > All Programs > Cypress > PSoC Designer <version> > PSoC Designer <version>**.
2. Click **File > New Project** to create a new project on the PSoC Designer menu or go to **File > Open Project/Workspace** to work with the existing project on the PSoC Designer menu

Figure 2-7. PSoC Designer Interconnect View

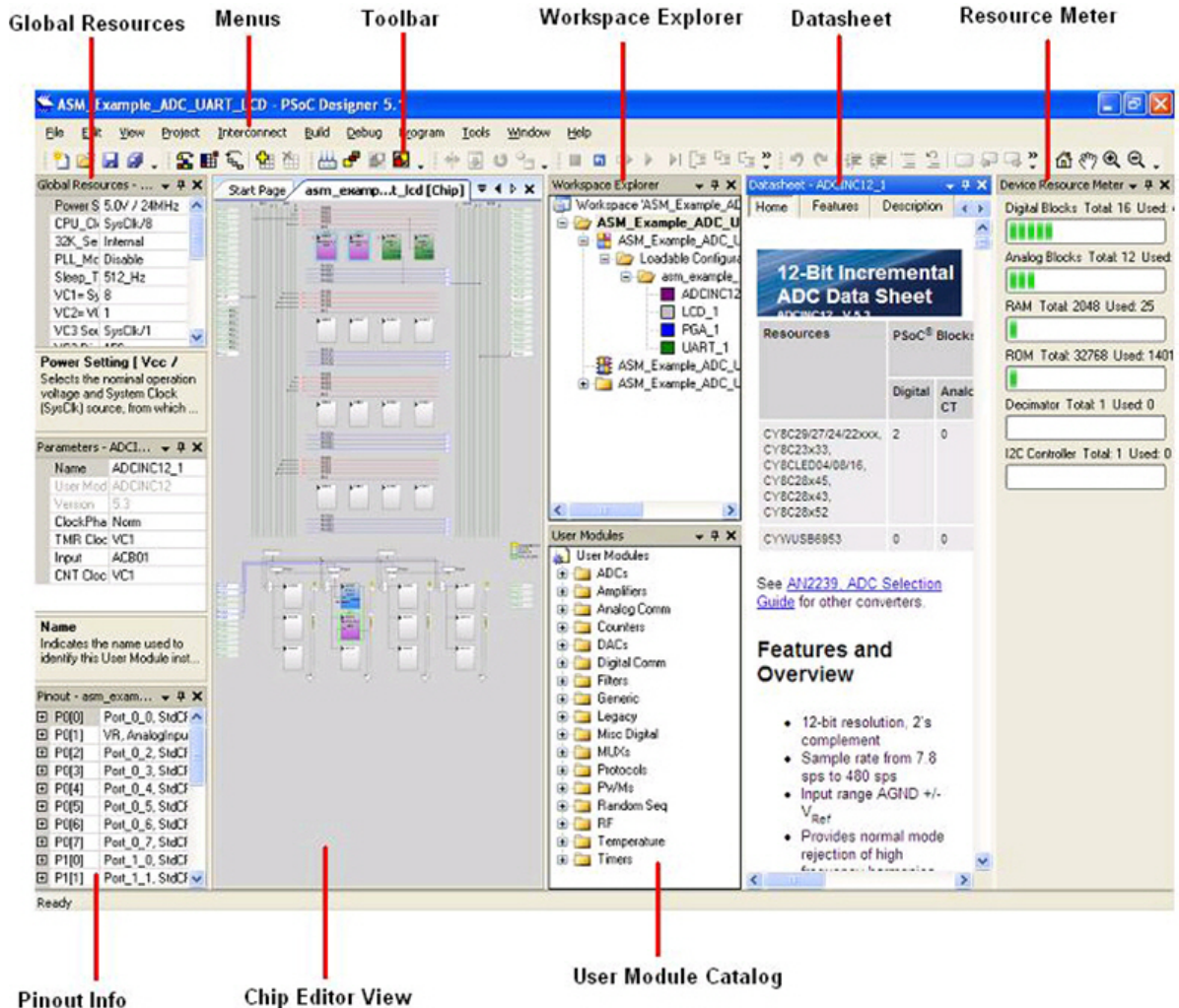

3. For more details on PSoC Designer, go to **Help Topics** from the following directory:

<Install_Dir>\Cypress\PSoC Designer\<version>\PSoC Designer 5\Help\PSoCDesigner (Compiled HTML Help file)

2.3 PSoC Programmer

1. Click **Start > All Programs > Cypress > PSoC Programmer <version> > PSoC Programmer <version>**.
2. Connect the MiniProg from **Port Selection**.

Figure 2-8. PSoC Programmer Window

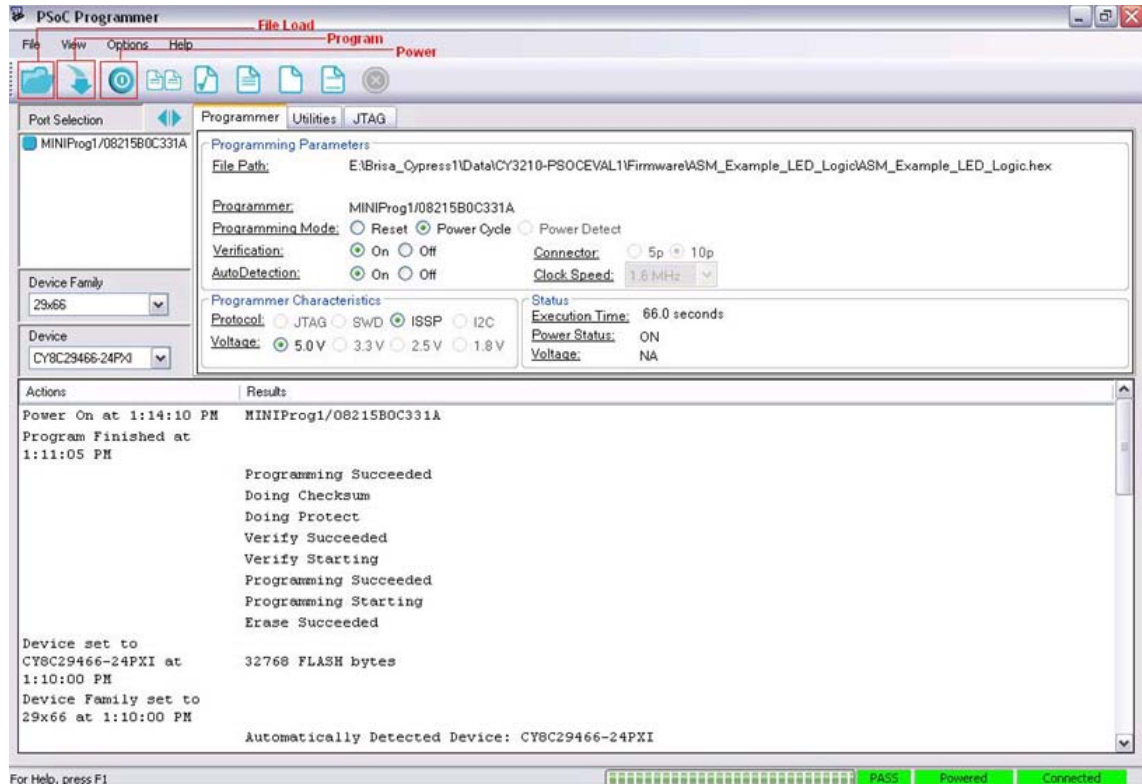

3. Click the File Load button to load the hex file.
4. Use the Program button to program the hex file on to the chip.
5. When the file is successfully programmed, Programming Succeeded appears on the Action pane.
6. Close PSoC Programmer.

Note For more details on PSoC Programmer, go to **Help Topics** from the following path:
 <Install_Dir>\Cypress\Programmer\<version>\PSoC_Programmer(Compiled HTML Help file)

2.4 Software Installation

2.4.1 Before You Begin

All Cypress software installations require administrator privileges; however, this is not required to run the installed software.

- Shutdown any Cypress software that is currently running.
- Disconnect any Cypress devices (USB-I2C bridge, ICE Cube, or MiniProg) from your computer.

2.4.2 Prerequisites

The PLC Control Panel GUI requires the latest versions of Microsoft .NET Framework, Adobe Acrobat Reader, and a Windows Installer. If your computer does not have .NET Framework and Windows Installer, the installation automatically installs it. However, if your computer does not have Adobe Acrobat Reader, download and install it from the Adobe website.

2.4.3 Installing PLC Control Panel Software

The PLC Control Panel GUI is installed as a prerequisite when you install the CY3274 PLC HV Development kit. Follow the steps shown on the screen to complete the installation. If you need to reinstall this application, select Install PLC Control Panel GUI from the installation screen, as shown in [Figure 2-1 on page 11](#).

Click **Start > All Programs > Cypress > PLC Control Panel > PLC Control Panel**.

The PLC Control Panel application controls the CY3274 PLC HV Development Kit over USB interface from a PC. The application's startup display, when a board is attached and operating, is shown in the following figure.

Figure 2-9. PLC Control Panel

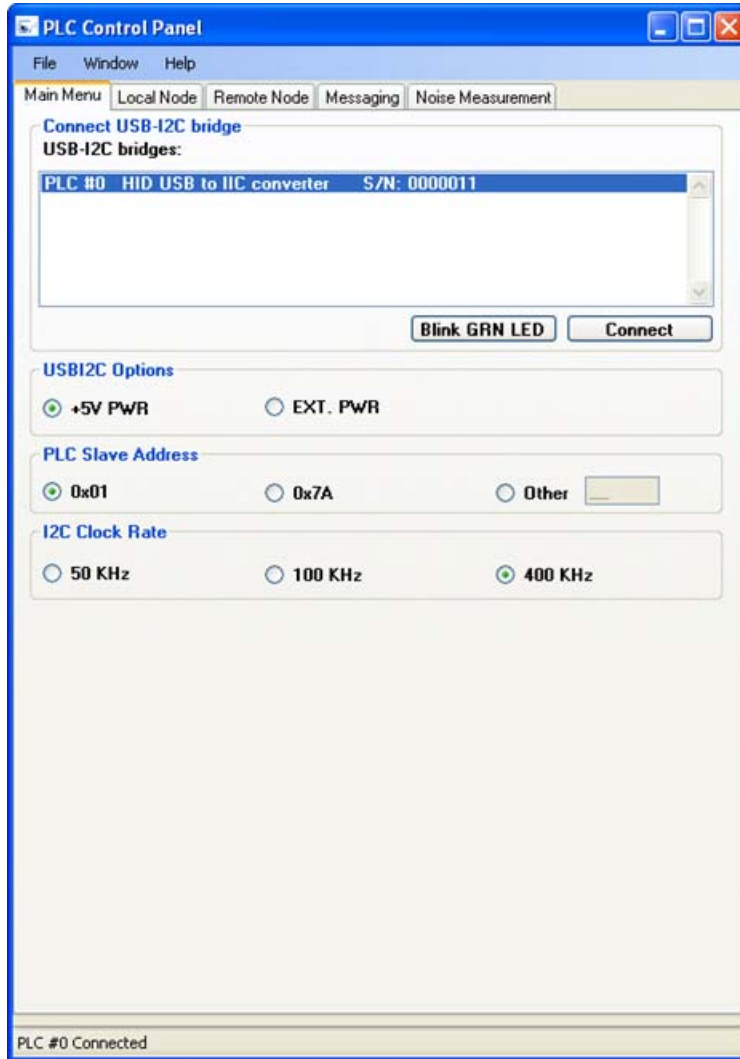

After installing PLC Control Panel, refer to the documentation as needed:

<CD Drive>\Software\PLC Control Panel\PLC Control Panel Release Notes.pdf

<CD Drive>\Software\PLC Control Panel\User Guide for Cypress PLC Control Panel GUI.pdf

The PLC Control Panel user guide is also available in the installation directory. It contains extra information about installation and how to set up the kit to work with the GUI. It can also be accessed from the Help menu in the PLC Control Panel GUI.



3. PLC Development Board



This chapter explains the key features of the CY3274 development board.

3.1 Features

The key features of the CY3274 development board are:

- User friendly PLC Control Panel application available on kit CD
- CY8CPLC20-OCD – 100-pin TQFP on-chip debug (OCD) device that allows quick design and debug of a PLC application.
The CY8CPLC20 100-pin TQFP is available for debug purpose only. For production quantities, CY8CPLC20 is available in 28-pin SSOP and 48-pin QFN packages.

- Chip power supply derived from 110 V to 240 V AC
- User configurable general purpose LEDs
- General purpose 8-position DIP switch
- On board surge protection and isolation circuit
- RJ45 connector to use ICE debugger
- RS232 COM port for communication
- Header to attach the LCD card
- I²C header for communicating to external device
- ISSP header for programming the CY8CPLC20

3.2 CY3274 PLC Development Board Functional Overview

The CY3274 PLC development board is designed as a product development platform for low bandwidth (up to 2400 bps) powerline communication.

The user-written application running on the CY8CPLC20 generates the data. The PLC core encapsulates this data into a PLC network packet. The FSK modem then modulates this packet and the coupling circuitry incorporates the resulting sinusoidal waveform on to the existing waveform on the high voltage bus.

3.2.1 Operating Conditions

- Input voltage: 110 V AC/240 V AC
- Input current: 100 mA/50 mA
- Operating temperature: 0 °C to 40 °C
- Operating humidity condition: 5% to 95% relative humidity (RH), non-condensing

3.3 Hardware Description

The programmable high voltage PLC development board is shown in [Figure 3-1](#). Key sections on the board are highlighted.

Figure 3-1. Front View of Cypress Programmable PLC HV Development Board

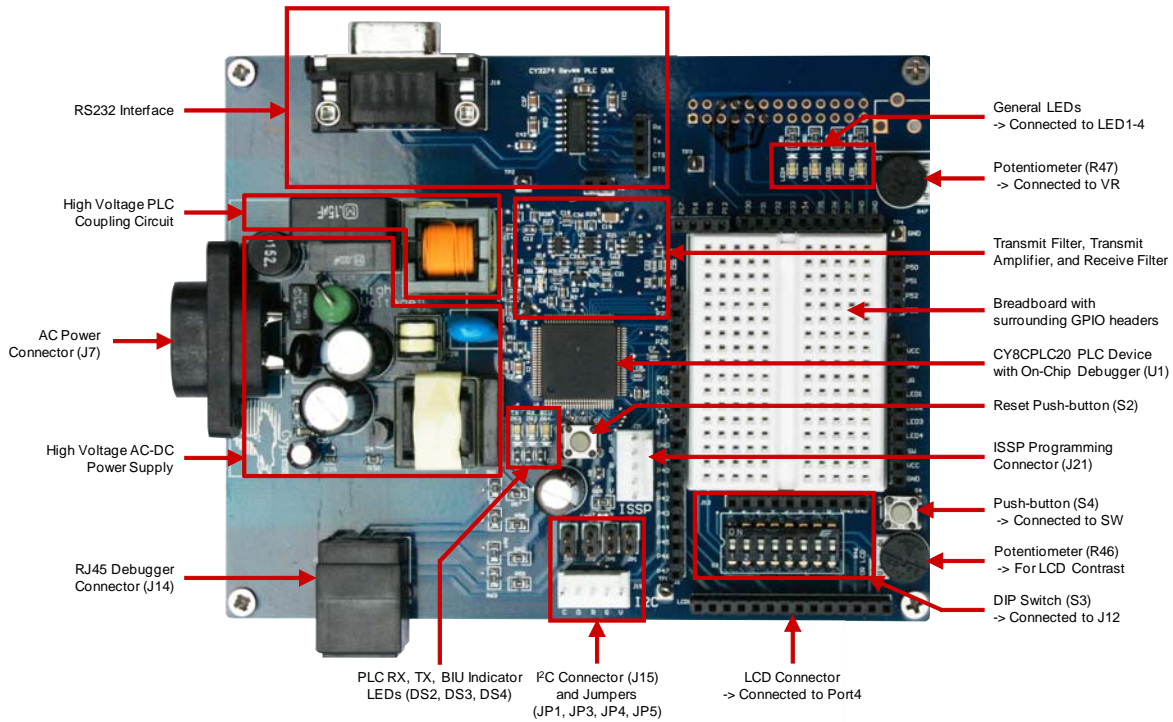

The core of the PLC HV board is the CY8CPLC20 chip. The communication signal flows on this HV board as follows:

Transmit: CY8CPLC20 TX pin (FSK_OUT) → Transmitter Filter Circuitry → Power Amplifier Circuitry → High Voltage Powerline Coupling Circuitry → High Voltage Powerline (110 V to 240 V AC)

Receive: High Voltage Powerline (110 V to 240 V AC) → High Voltage Powerline Coupling Circuitry → Passive Low Pass Filtering → Vdd/2 Biasing → CY8CPLC20 RX pin (FSK_IN)

The CY3274 board can be divided into seven main sections:

- Development
- LCD daughter card
- RJ45 connector for debugging
- RS232 COM port
- High voltage with SMPS
- Transmit amplifier and filtering
- High voltage coupling circuit

3.3.1 Development

3.3.1.1 User I/Os, Bread Board and GPIO Headers

This is the area where you make custom designs. All GPIO pins excluding those required for PLC communication are routed to this area for ease of access. Some of the pins are shared for other purposes (for example, the port 4 pins P4[6:0] are also connected to the LCD connector).

Header J18 has pins that are connected to user I/Os (potentiometer, push-button, and LEDs). In [Figure 3-2](#), these connections are represented by the green arrows. To connect one of these user I/Os to a CY8CPLC20 pin, connect a jumper wire between the respective header pins. For example, to connect the push-button S4 to pin P1[6], place a jumper wire in SW on header J18 and the other end in P16 on header J9.

The DIP switch bank S3 is not connected directly to any of the CY8CPLC20 pins. The DIP switch is connected to header J12, so that a jumper wire can be connected to any of the pins. The DIP switch is active LOW (connected to GND when in the ON position).

Figure 3-2. Bread Board

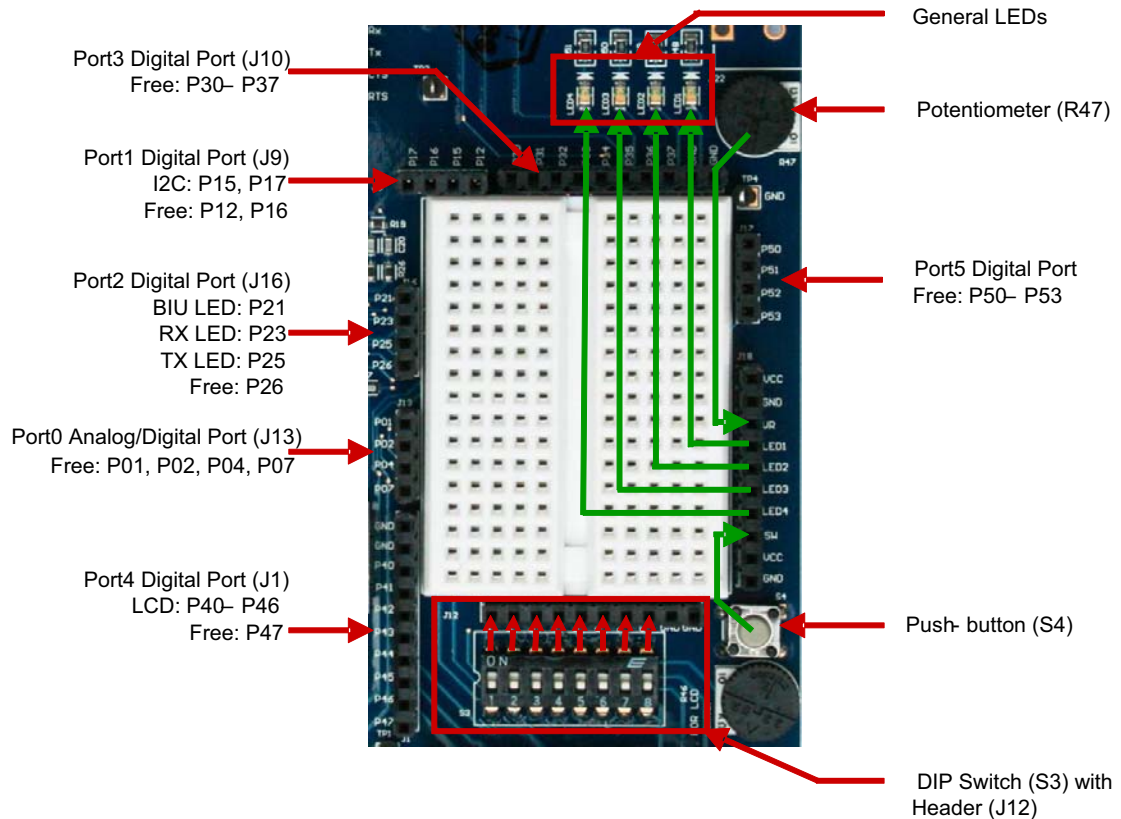

3.3.1.2 CY8CPLC20 PLC Device

This section has the CY8CPLC20-OCD device, which has the integrated transmit and receive modem and network protocol. It also has the I²C header for optional communication with an external host processor. The ISSP header is provided to program the device. The device also has built-in debug support using the RJ45 connector for use with the ICE debugger. There are also three dedicated LEDs, which can be used to indicate communication on the powerline: green LED for TX, red LED for RX, and yellow LED for BIU.

Figure 3-3. The Development Section

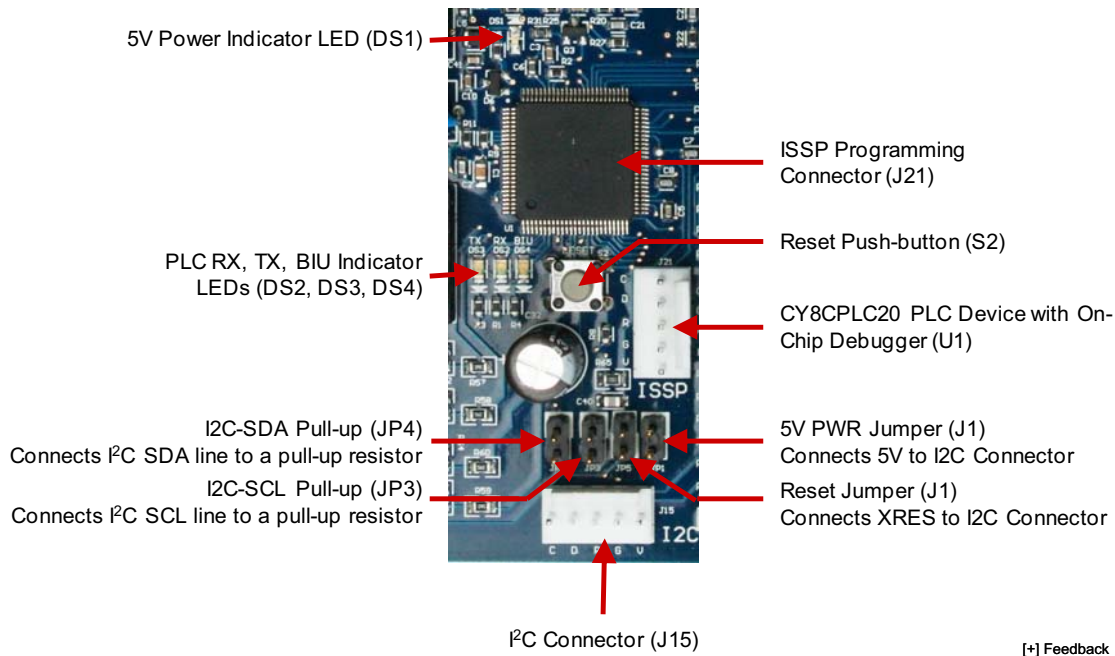

Table 3-1. Headers and Jumpers

Headers and Jumpers	Description
BIU LED[DS4]	Yellow LED that can be used to indicate when the transmit frequency band is in use.
CY8CPLC20-OCD	Cypress Powerline transceiver chip. It is a 100-pin on-chip debugger (OCD) device.
J8	Two-pin header for connecting to Vcc and Gnd for debug. Do not use these pins to power an external board.
JP1 (PWR)	This jumper should be connected to power an external board. After this jumper is connected, power for the external board can be derived from the V (V _{DD}) and G (Gnd) connectors on the I2C header (J15). The CY3274 board can provide a maximum of 50 mA at 5 V to an external board through the V and G pins on the I2C header (J15).
JP5 (Reset)	The jumper enables the reset of the PLC device through an external board. After this jumper is connected, the external board reset can be connected to the R (Reset) pin on the I2C header (J15).

Headers and Jumpers	Description
JP4 (I2C-SDA)	<p>This is a pull-up jumper. While communicating through I2C (J15), one side has to pull up the line. When the jumper is connected, the SDA line is pulled high. This needs to be done when the user wants the I2C link to be pulled up by the CY3274 board.</p> <p>This jumper does not need to be placed if the USB-I2C bridge is used for communication to the host.</p>
JP3 (I2C-SCL)	<p>This is a pull-up jumper. While communicating through I2C (J15), one side has to pull up the line. When the jumper is connected, the SCL line is pulled high. This needs to be done when the user wants the I2C link to be pulled up by the CY3274 board.</p> <p>This jumper does not need to be placed if the USB-I2C bridge is used for communication to the host.</p>
J15	<p>V – V_{DD}. This pin can provide a maximum of 50 mA at 5 V to an external board. This pin is only to source the current. DO NOT SUPPLY POWER TO THIS PIN FOR POWERING CY8CPLC20 DEVICE. Note that the PWR jumper (JP1) needs to be connected to enable this functionality.</p> <p>G – Gnd. The Gnd pin can provide the ground reference to an external board. This pin connects to the ground plane of the CY3274 board.</p> <p>D – I²C data (SDA). The I²C data pin is the data line for the I2C communication. This pin is directly connected to the CY8CPLC20 device. See appropriate I2C-SDA jumper (JP4) settings before connecting I2C bus to this pin.</p> <p>C – I²C clock (SCL). The I²C clock pin is the clock line for the I2C communication. This pin is directly connected to the CY8CPLC20 device. See appropriate I2C-SCL jumper (JP3) settings before connecting I2C bus to this pin.</p> <p>R – Reset. Connecting this pin to an external board enables the CY8CPLC20 chip to be reset by an external board. Note that the RES jumper (JP5) needs to be connected to enable this functionality.</p>
LCD Contrast[R46]	Adjusting this potentiometer adjusts the contrast on the LCD Daughter Card.
LED1-LED4	Headers connected to general purpose configurable LEDs.
PWR LED[DS1]	Blue LED that glows when the board is powered on.
P01, P02, P04, P07	Free analog/digital port pins
P15	Port pin connected to SDA for I2C
P16, P12	Free port pins
P17	Port pin connected to SCL for I2C
P21	Port pin connected to yellow LED for BIU
P23	Port pin connected to red LED for RX
P25	Port pin connected to green LED for TX
P26	Free port pin
P30, P31, P32, P33, P34, P35, P36, P37	Free port pins
P40-P46	Port pins connected to LCD card
P47	Free port pin
P50, P51, P52, P53	Free port pins

Headers and Jumpers	Description
R47	This is a variable resistor (potentiometer) that connects to the VR header. It can be used to generate a voltage between +5 V and GND.
RX LED[DS2]	Red LED that can be used to indicate when the board is receiving data
S2	Reset switch for resetting the CY8CPLC20-OCD chip
S3[7-0]	These dip switches are general purpose and can be routed to any port of the CY8CPLC20 chip.
SW	Header connected to the switch S4. S4 is a general purpose switch. Active HIGH (connected to V _{DD} when pressed).
TP1, TP2, TP3, TP4	Grounded test points to facilitate probing/debugging. These test points connect to the board ground plane.
TX LED[DS3]	Green LED that can be used to indicate when the board is transmitting data on to the powerline
VR	Header connected to the potentiometer R47

3.3.2 LCD Daughter Card

The LCD module is connected to header LCD1 and controlled with the CY8CPLC20 port 4 pins P4[6:0].

Figure 3-4. LCD Daughter Card



Connect the LCD daughter card to the main board as shown in [Figure 3-5](#). The contrast of the LCD is controlled by the potentiometer R46.

Figure 3-5. LCD Daughter Card Board Connection

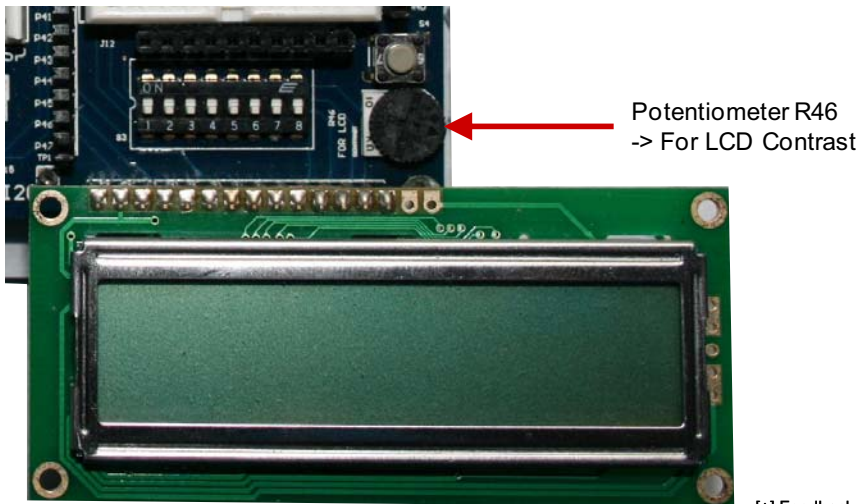

[+] Feedback

3.3.3 RJ45 Connector for Debugging

The RJ45 ICE Cube Emulation Connector (J14) provides a debug interface between the CY8CPLC20 device and the ICE Cube emulation tool using the PSoC Designer software application. A CY3215-DK In-Circuit Emulation Development kit is required to interface the PC to this board. It can be purchased at <http://www.cypress.com/go/CY3215-DK>.

Figure 3-6. RJ45 Connector

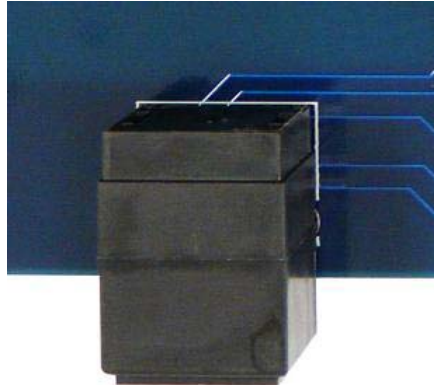

3.3.4 RS232 COM Port

The RS232 COM Port can be used with a standard RS232 cable to connect two RS232 capable devices together. The RS232 (J20) header is a four pin header that has connections for the RX, TX, RTS, and CTS lines. These need to be wired to port pins to connect the device to the respective pins on the RS232 DB9 port.

Figure 3-7. RS232-COM

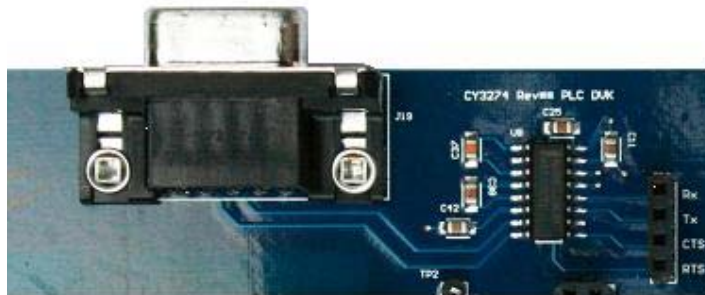

Table 3-2. Controls Associated with Port

Control	Description
RX	The board receives the RS232 information through this pin.
TX	The board transmits RS232 information through this pin.
RTS	The host asks the chip if it can send information through this pin.
CTS	The chip signals that it is ready to accept information through RX.

3.3.5 High Voltage with Switched Mode Power Supply (SMPS)

This section takes the power from the powerline and generates necessary low DC voltage for the operation of the PLC transceiver and other components on the chip.

Table 3-3. Key High Voltage with SMPS Components

Component	Description
J7	This is the two pin connector where the AC cable hooks up to the powerline.
F1	Protection fuse for the circuit.
D7	Full wave bridge rectifier diode IC.
T3	Common mode choke.
U6	iW1690-07 – iWatt high performance AC/DC power supply controller.
T2	Flyback transformer.
U5	5-V regulator.

The key components are circled in the following schematic

Figure 3-8. Power Supply Schematic

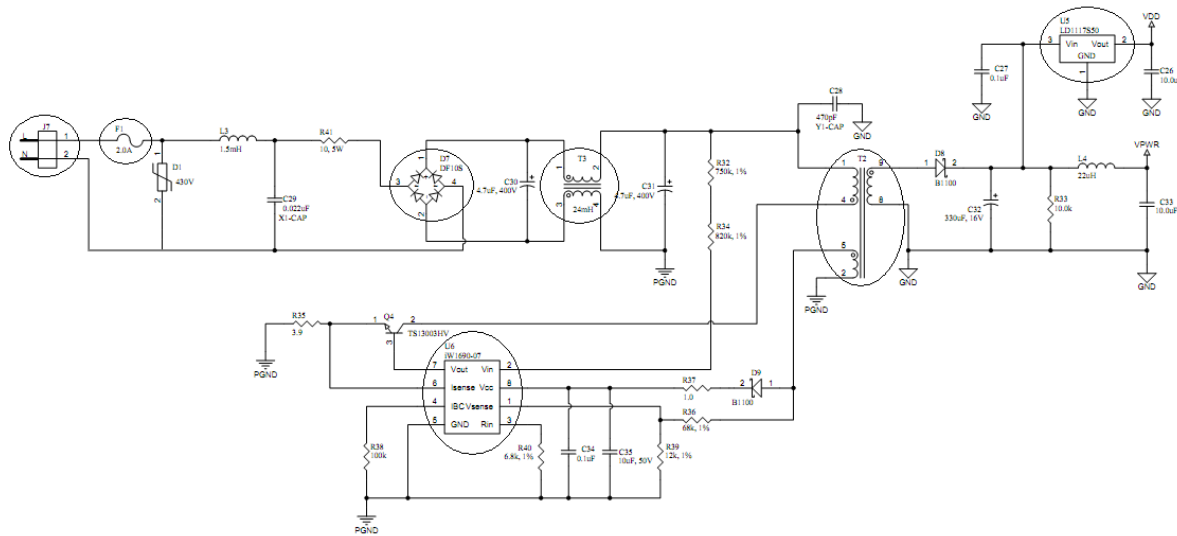

3.3.6 Transmit Filter, Transmit Amplifier, and Receive Filter

The transmit signal from the FSK_OUT pin of the CY8CPLC20 device is filtered (for FCC and CENELEC compliance) and amplified (for driving the signal on the powerline). The passive receive filter prepares the signal for the FSK_IN pin of the CY8CPLC20 device.

Table 3-4. Key Transmit Amplifier and Filtering Components

Component	Description
U2, U3	These opamps filter the signal from the CY8CPLC20 removing the harmonics. The filter stages are only required to meet FCC Part 15 and/or European CENELEC EN50065-1:2001 signaling specifications. They are not required to achieve robust PLC communication.
U4, Q1, Q2	These opamp and high gain transistors are used for the power amplification stage.

The key components are circled in the following schematic.

Figure 3-9. Transmit Filter, Transmit Amplifier, and Receive Filter

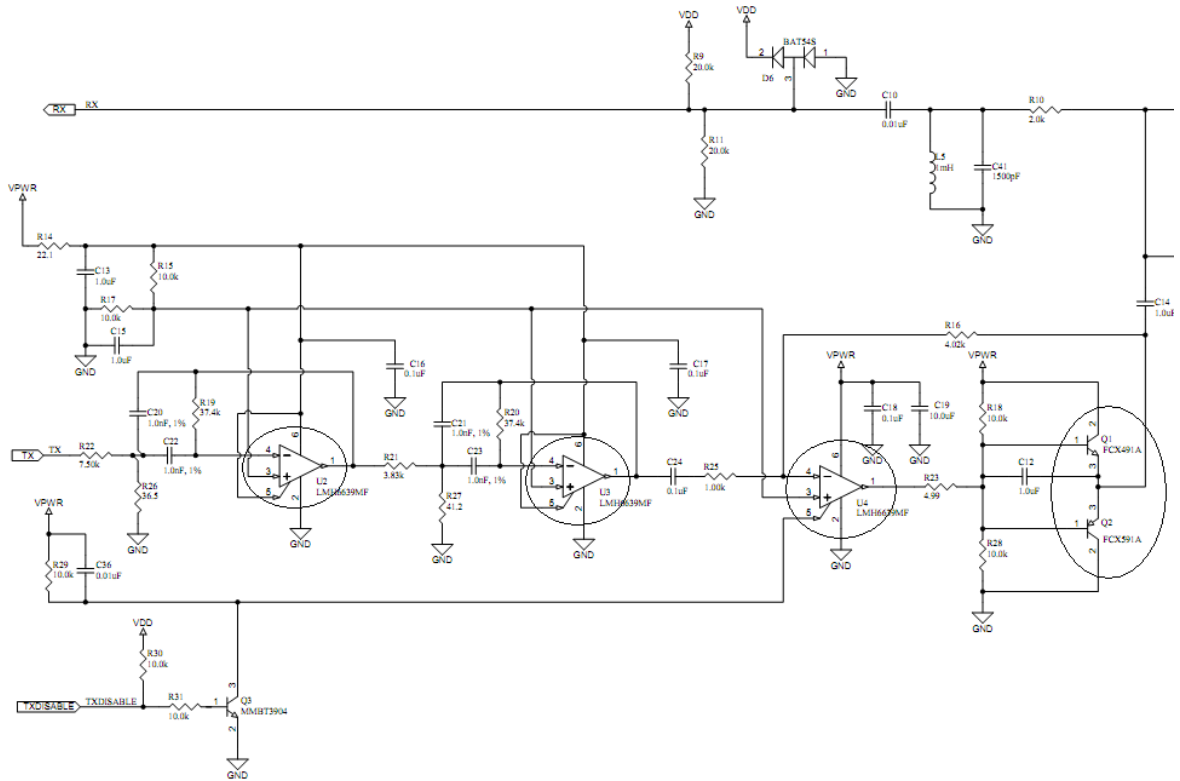

3.3.7 High Voltage Coupling Circuit

This circuit couples the signal from the board on to the powerline. On the receive side, the same circuit couples the carrier on the powerline into the board, while rejecting the actual 50-Hz and 60-Hz power. The isolation transformer in the circuit is required for safety.

Table 3-5. Key Transmit and Receive Components

Component	Description
T1	This is the isolation transformer that isolates the HV and LV sections of the board. It has a 1:1 turns ratio.
C9	This is the coupling capacitor that couples the communication signal to the powerline and rejects low frequency noise. The voltage rating and X1/X2 safety ratings of this component are important parameters.

The key components are circled in the following figure.

Figure 3-10. Coupling Circuit

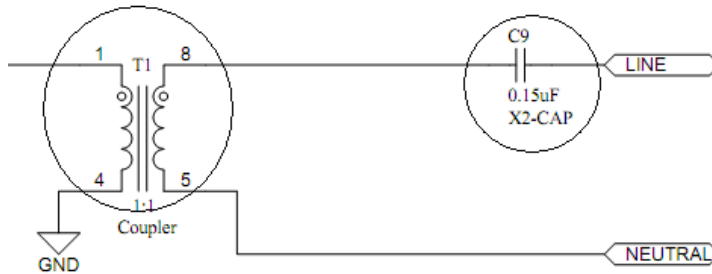

3.4 Code Example

The CY3274 kit is designed for systems that require a communication interface over commercial high-voltage Powerlines. The CY8CPLC20 device combines the robustness and ease-of-use of the PLC solution with the configurability and flexibility of the PSoC core. The CY8CPLC20 device provides the ability to run your own application. The PLT User Module manages the network protocol and the physical layer FSK modem, which transmits and receives messages over the powerline. For more information on this user module, see [AN54416, Using CY8CPLC20 in Powerline Communication \(PLC\) Applications](#).

3.5 Technical Reference

For a real-time list of knowledge base articles for the CY3274 Kit, refer to our [Online Knowledge Base](#).

For any help with the installation of the control panel, refer to the Control Panel User Guide provided in the kit CD. You can also download the latest revision of the GUI setup and user guide from www.cypress.com/go/plc.

A. Appendix



A.1 Schematics

A.1.1 Board Overview

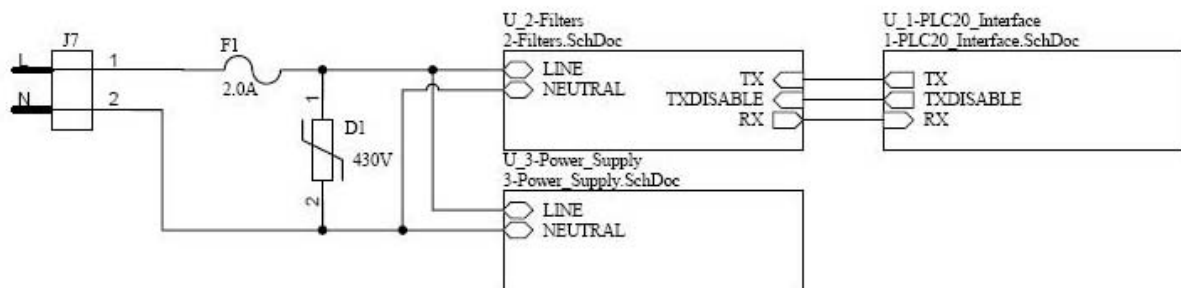

A.1.2 User Interface

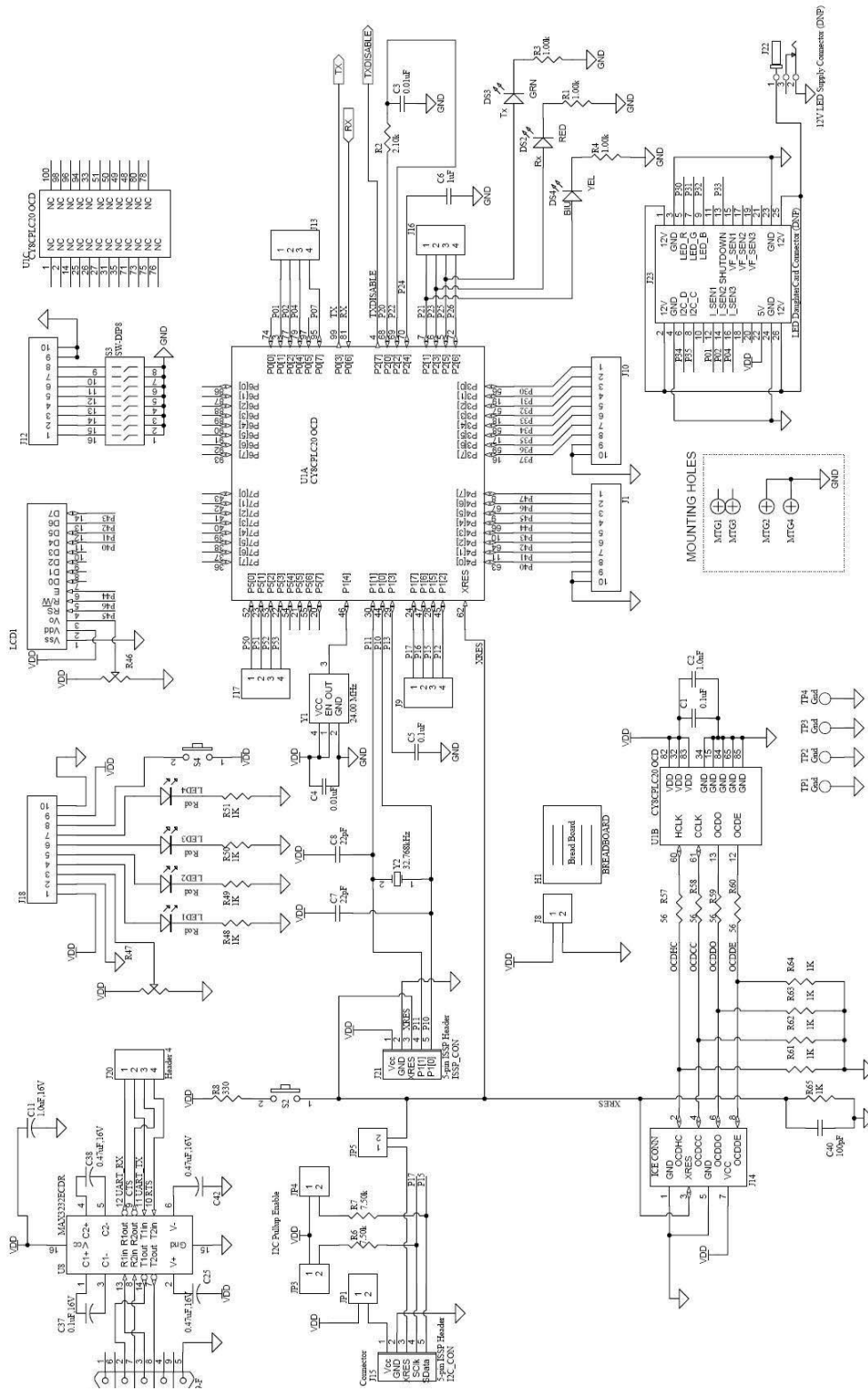

A.1.3 Transmit and Receive Filters and Coupling

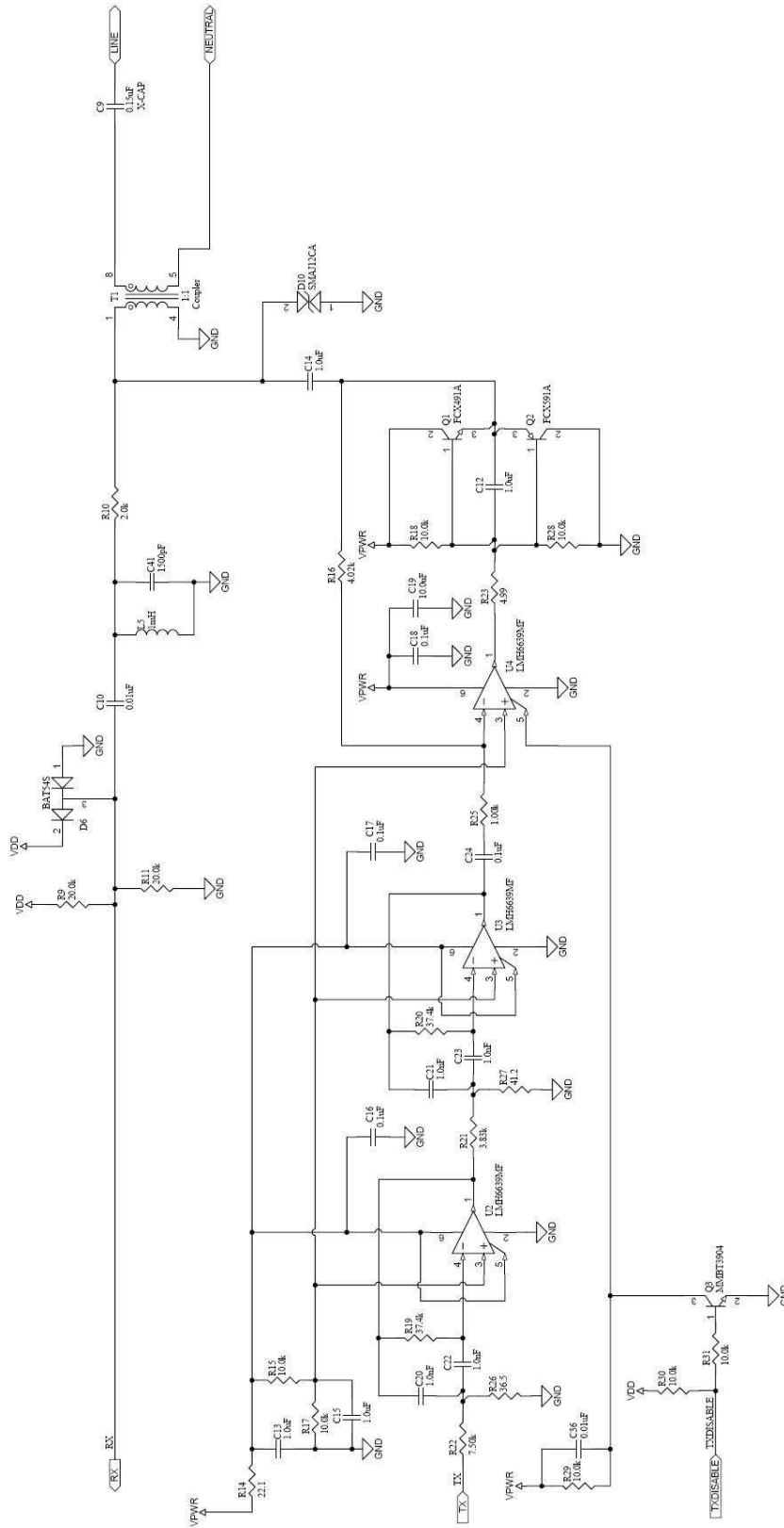

A.1.4 Power Supply

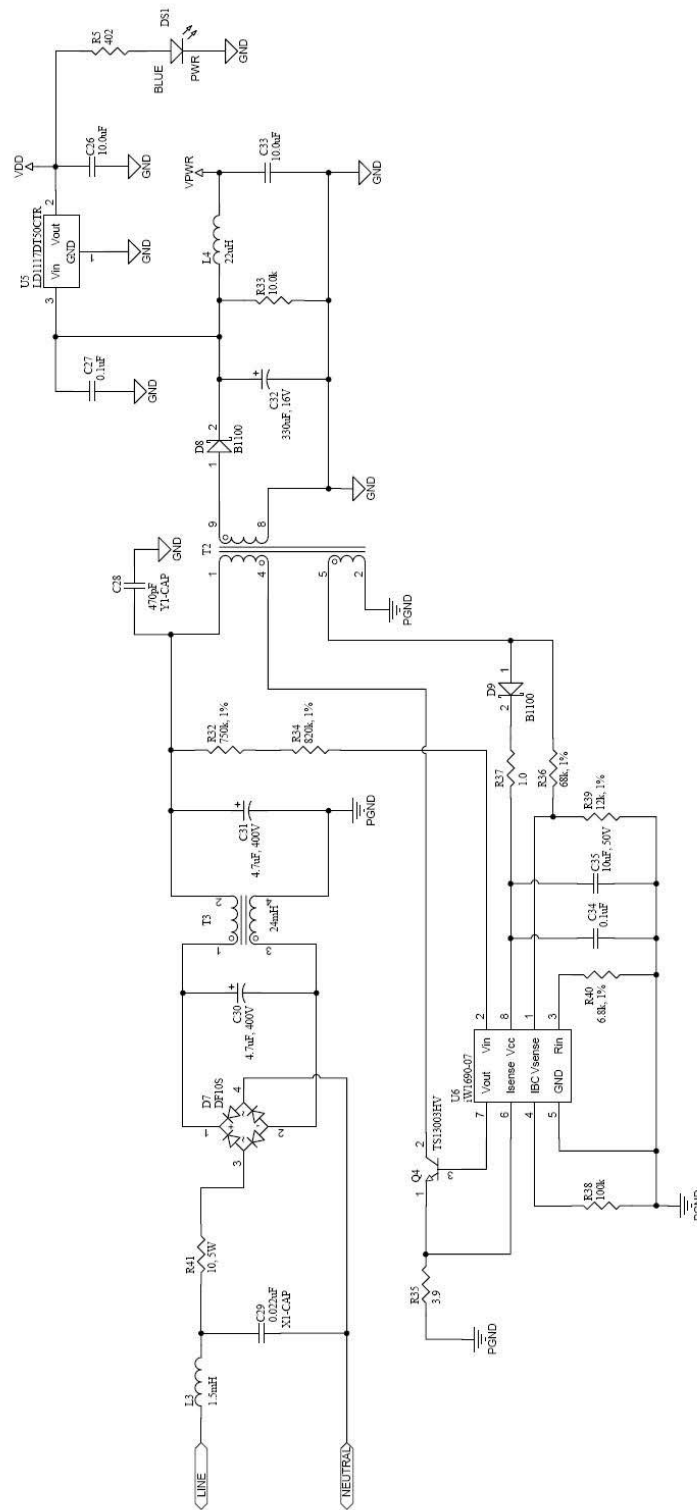

A.2 Layout

A.2.1 Top Layer

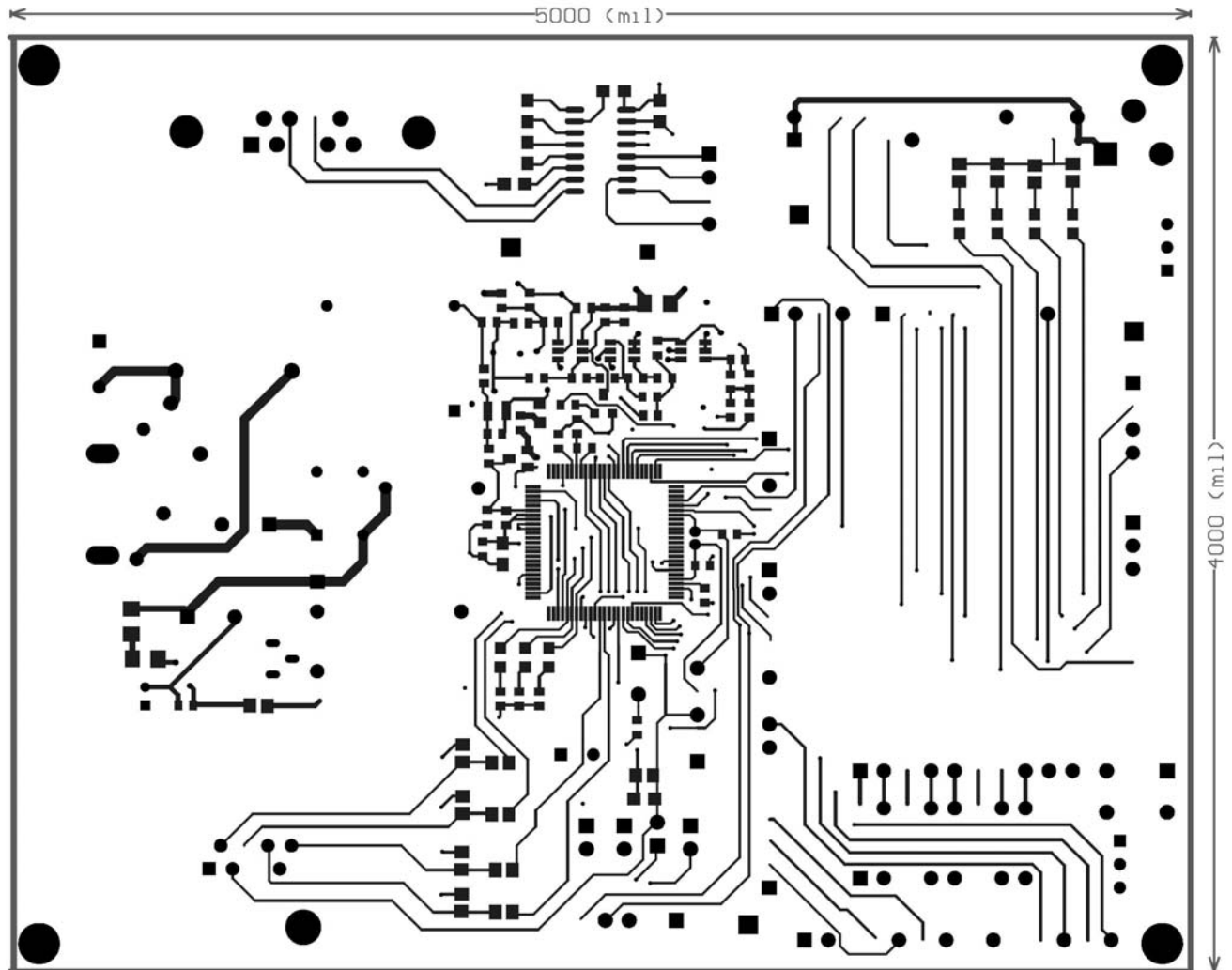

A.2.2 Ground Layer

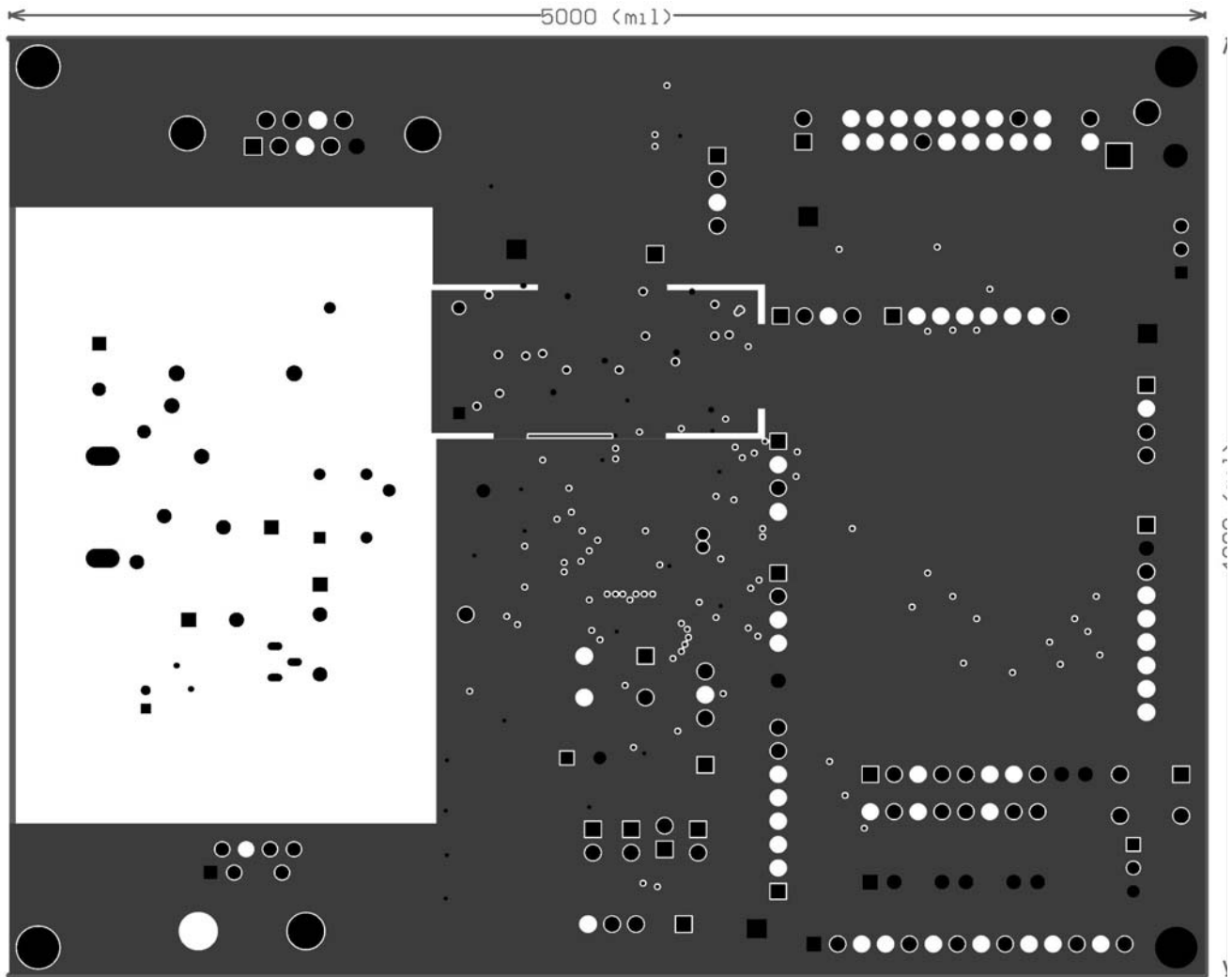

A.2.3 Power Layer

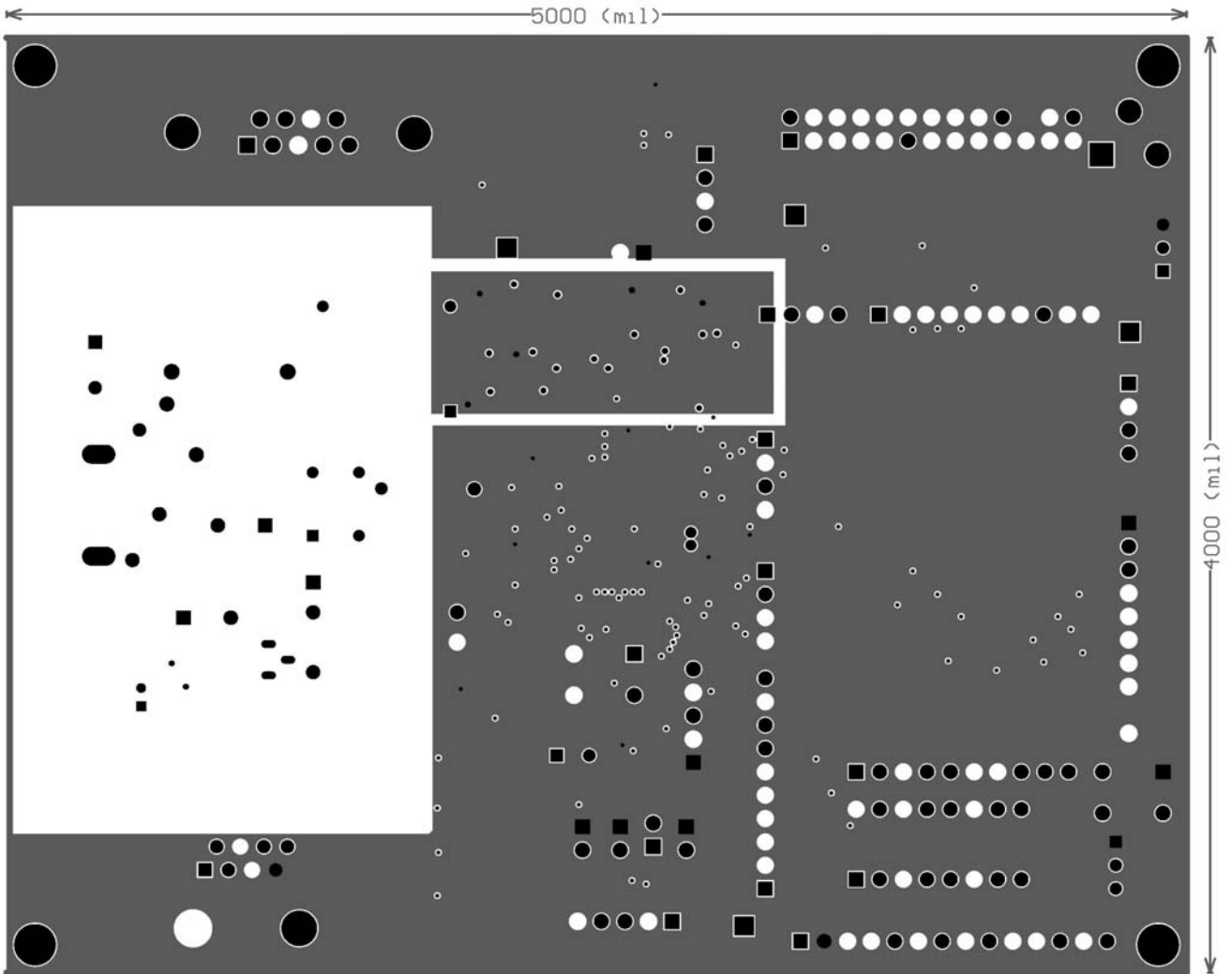

A.2.4 Bottom Layer

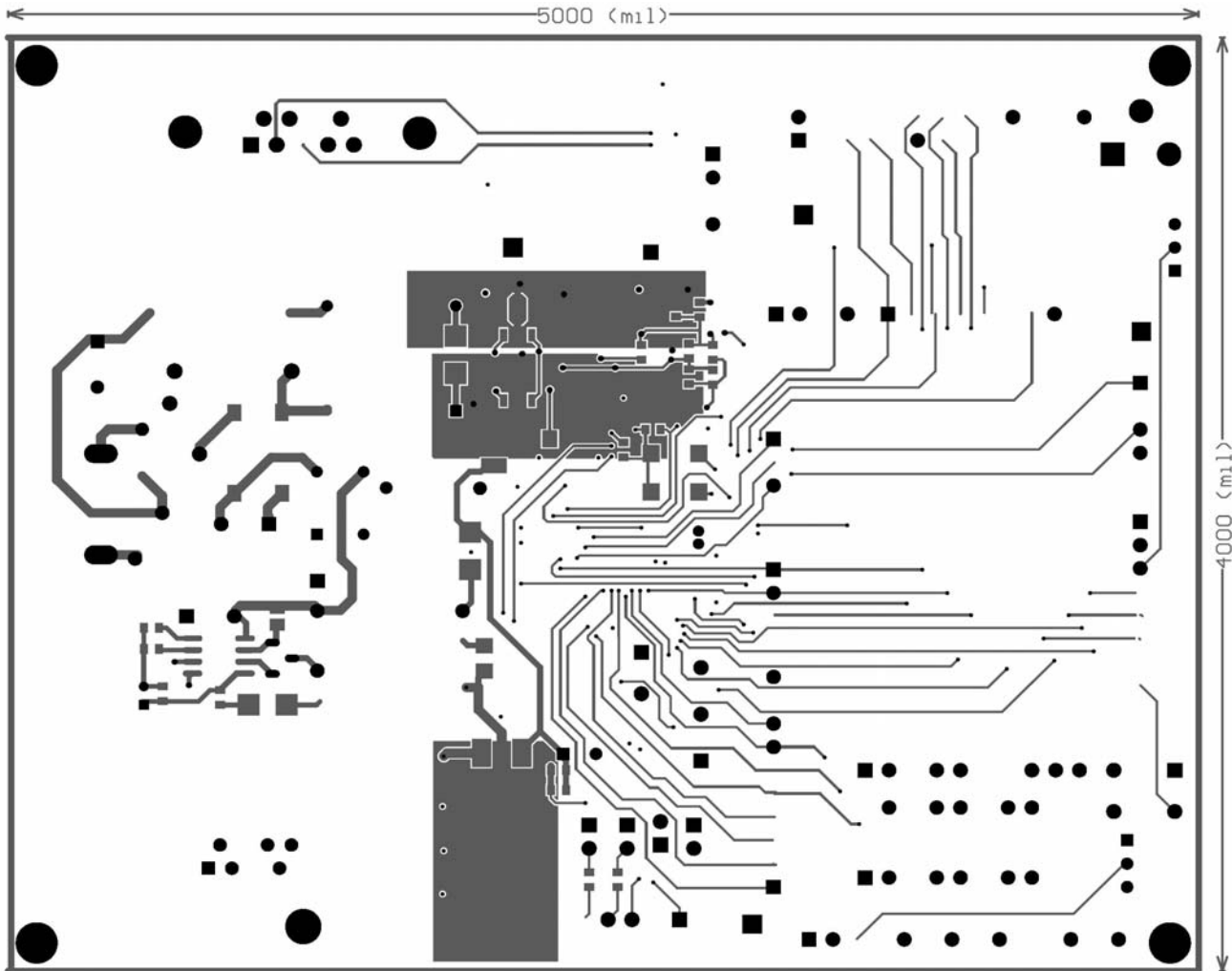

A.2.5 Top Silkscreen

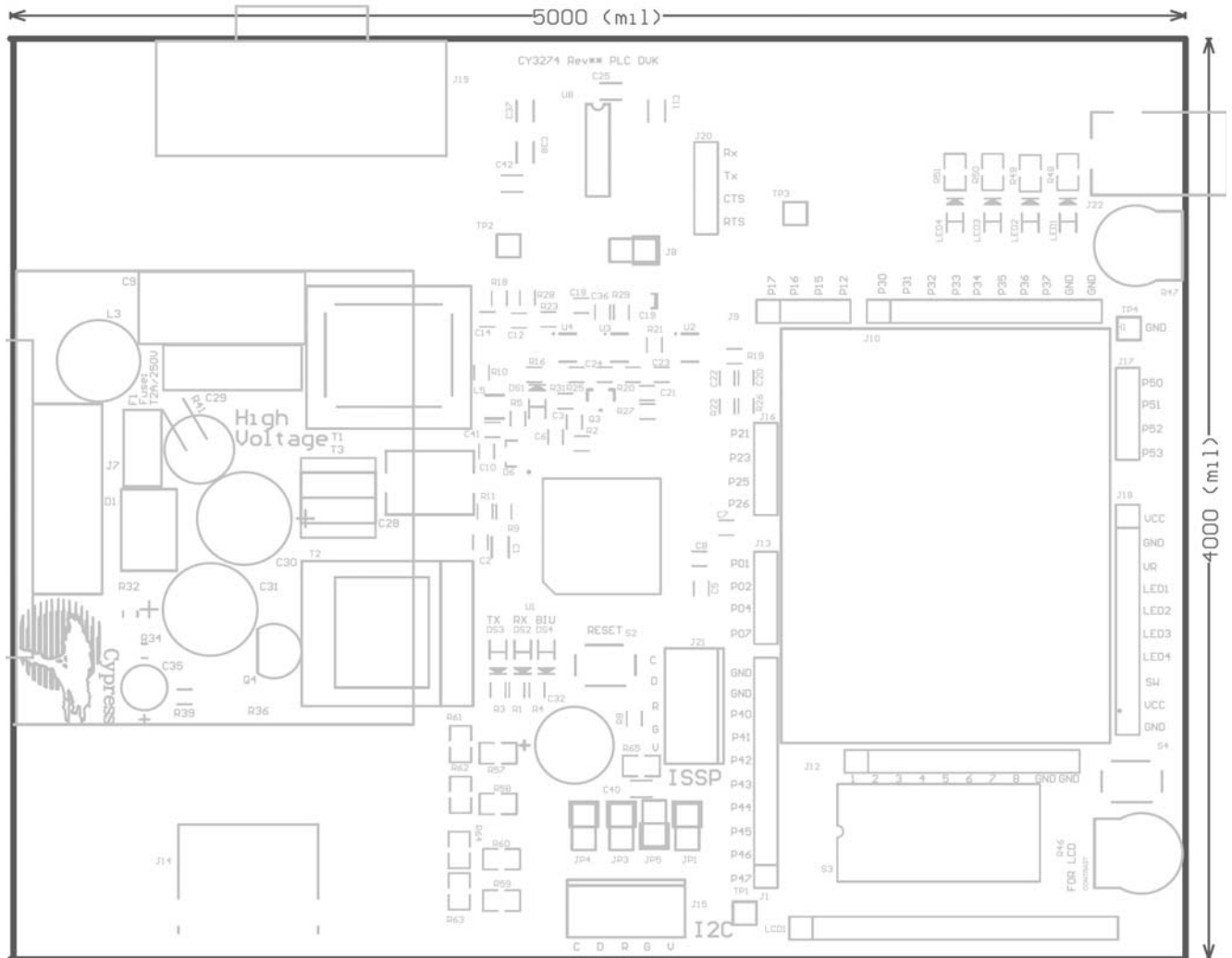

A.2.6 Bottom Silkscreen

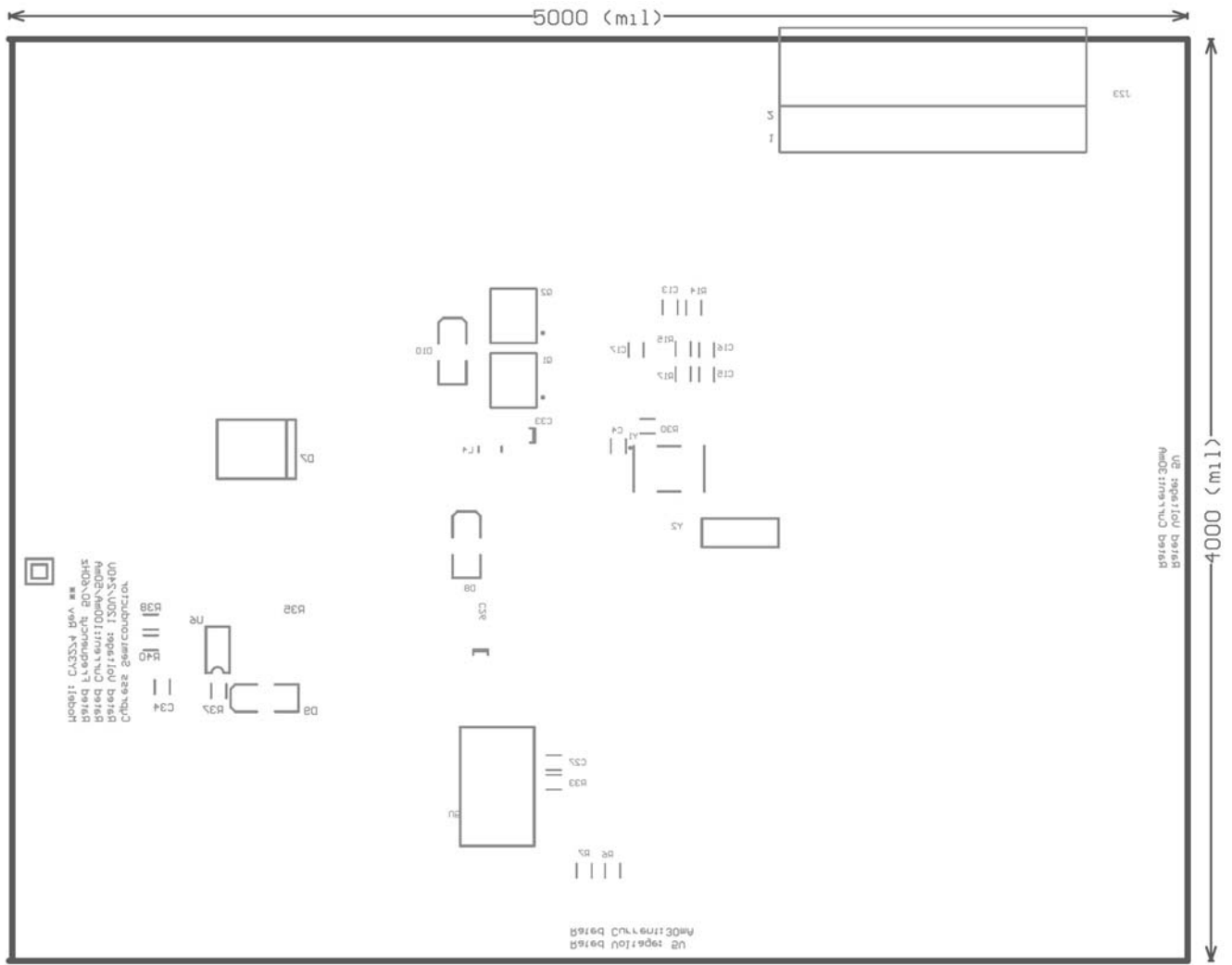

A.3 Bill of Materials

Description	Designator	Quantity	Value	Manufacturer	Manufacturer Part#	Digi-Key#
Capacitor 0.1 μ F	C1	1	0.1 μ F			PCC1864TR-ND
Capacitor Ceramic 1.0 nF X7R 10% 25V C0603	C2	1	1.0nF	Murata	GRM033R71E1 02KA01D	490-3184-1-ND
Capacitor Ceramic 0.01 μ F 25V X7R 0603	C3, C4, C10, C36	4	0.01 μ F	AVX	06033C103JAT 2A	06033C103JAT2A -ND
Capacitor Ceramic 0.1 μ F 25V X7R 0603	C5	1	0.1 μ F	AVX	06033C104JAT 2A	478-3713-1-ND
Capacitor Ceramic 1.0 μ F 16V X7R 0603	C6, C12, C13, C14, C15	5	1.0 μ F, 1 μ F	Taiyo Yuden	EMK107B7105 KA-T	587-1241-1-ND
Capacitor Ceramic 22 pF 100V C0G 0603	C7, C8	2	22pF	Murata	GRM1885C2A2 20JA01D	490-1335-1-ND
CAP .15UF 300VAC INTER SUPP X1	C9	1	0.15 μ F	Murata	ECQ- U3A154MG	P11117-ND
Capacitor 1.0 μ F, 16V	C11	1	1.0 μ F,16V			PCC1849TR-ND
CAP CERM 0.10 UF 10% 16V X7R 0603	C16, C17, C18, C24, C27, C34	6	0.1 μ F	Panasonic	ECJ- 1VB1C104K	PCC1762CT-ND
CAP CERM 10.0 UF 10% 25V X5R 1206	C19, C26, C33	3	10.0 μ F	Taiyo Yuden	TMK316BJ106 KL-T	587-1337-1-ND
Capacitor Ceramic 1000 PF 1% 5V NP0 0603	C20, C21, C22, C23	4	1.0nF	AVX	06033A102FAT 2A	06033A102FAT2A -ND
Capacitor 0.47 μ F, 16V	C25, C38, C42	3	0.47 μ F,16V			PCC1847TR-ND
Capacitor Ceramic 470 PF 250VAC X1Y1 RAD	C28	1	470pF	TDK	CD95- B2GA471KYNS	445-2407-ND
CAP .022UF 300VAC INTER SUPP X1	C29	1	0.022 μ F	Panasonic	ECQ- U3A223MG	P11112-ND
Capacitor Electrolytic 4.7 μ F, 400V	C30, C31	2	4.7 μ F, 400V	Nichicon	UVR2G4R7MP D	493-1229-ND
	C30, C31 (2nd Source, 105C rated)		4.7 μ F, 400V	United Chemi- Con	EKMG401ELL4 R7MJ16S	565-1411-ND
Capacitor Electrolytic 330 μ F 16V 20%	C32	1	330 μ F, 16V	Nichicon	UPW1C331MP D	493-1784-ND

Description	Designator	Quantity	Value	Manufacturer	Manufacturer Part#	Digi-Key#
Capacitor Electrolytic 10 μ F 50V 20%	C35	1	10 μ F, 50V	Nichicon	UPW1H100MD D	493-1890-ND
Capacitor 0.1 μ F, 16V	C37	1	0.1 μ F,16V			PCC1864TR-ND
Capacitor 100 pF	C40	1	100pF			399-1121-2-ND
Capacitor Ceramic 1500 pF 10% 50V X7R 0603	C41	1	1500pF	Yageo	CC0603KRX7R 9BB152	311-1184-2-ND
Transorb Voltage Sup- pressor 430 V 1250A ZNR	D1	1	430V	Panasonic	ERZ-V07D431	P7251-ND
Dual Schottky Diode	D6	1		ST Micro	BAT54SFILM	497-2522-1-ND
Full Wave Diode Bridge	D7	1		Fairchild	DF10S	DF10SCT-ND
Schottky Diode 100 V 1A SMA	D8, D9	2		Diodes Inc	B1100-13-F	B1100-FDICT-ND
Transient Voltage Sup- pressor 400 W 12 V BIDIRECT SMA	D10	1		Micro Com- mercial Co	SMAJ12CA-TP	SMAJ12CA-TPM- SCT-ND
LED Blue Clear 0603	DS1	1		Rohm	SML- E12BC7TT86	511-1589-1-ND
LED Red Clear 0805	DS2	1		Lite-On	LTST- C170KRKT	160-1415-1-ND
LED Green Clear 0805	DS3	1		Lite-On	LTST- C170KGKT	160-1414-1-ND
LED Yellow Clear 0805	DS4	1		Lite-On	LTST- C170KSKT	160-1416-1-ND
Fuse 2A Slow Blow 250 V AC	F1	1	2.0A	Bel Fuse	RST 2	507-1179-ND
3M solderless bread- board super strip	H1	1		Parallax	700-00012	923273-ND
Header, 10-Pin	J1, J10, J12, J18	4	10			929850E-01-36- ND
AC Power Connector	J7	1		Schurter	4300.0097	
Header, 2-Pin, Female	J8	1	2	Generic Com- ponents		929850E-01-36- ND
Header, 4-Pin	J9, J13, J17, J20	4	4			929850E-01-36- ND
ICE Connection	J14	1		Tyco	5557785-1	A31457-ND
5-pin ISSP Header	J15, J21	2		Molex	22-23-2051	WM4203-ND

Description	Designator	Quantity	Value	Manufacturer	Manufacturer Part#	Digi-Key#
Header, 4-Pin	J16	1	4			929850E-01-36-ND
Female DB-9	J19	1	DB9-F			A23301-ND
(DO NOT POPULATE) Power Connector Jack 2.1mm PCB	J22					
(DO NOT POPULATE) Right Angle 2X13 header 0.1" Spacing	J23					
Header, 2-Pin, Male	JP1, JP3, JP4, JP5	4	2	Generic Components		S1011E-36-ND
Inductor 1500 μ H 0.2A 5% Radial	L3	1	1.5mH	Taiyo Yuden	LHL08TB152J	LHL08TB152J-ND
Inductor 22 μ H 20% 1210	L4	1	22 μ H	Taiyo Yuden	CBC3225T220MR	587-1626-1-ND
Inductor 1 mH 10% 1007	L5	1	1mH	Taiyo Yuden	CB2518T102K	587-2195-1-ND
14-Pin header, Female	LCD1	1	14	3M/ESD	929850-01-36-RA	929850E-01-36-ND
Red LED	LED1, LED2, LED3, LED4	4	Red	Lumex Opto	SML-LXT0805IW-TR	67-1552-2-ND
Mounting Holes	MTG1, MTG2, MTG3, MTG4	4				
Transistor NPN HV 40 V 1A SOT-89	Q1	1		Zetex	FCX491ATA	FCX491ACT-ND
Transistor PNP HV 40 V 1A SOT-89	Q2	1		Zetex	FCX591A	FCX591ACT-ND
Transistor NPN SOT-23	Q3	1		Fairchild	MMBT3904LT1	MMBT3904LT1INCT-ND
NPN Silicon Planar Medium Power High-Gain Transistor	Q4	1		TSC	TS13003HVCT	
	Q4 (2nd source)			ST Micro	STX616-AP	497-7625-1-ND
Resistor 1.00k 1% 1/10 W 0603	R1, R3, R4, R25	4	1.00k	Yageo	RC0603FR-071KL	311-1.00KHRTR-ND

Description	Designator	Quantity	Value	Manufacturer	Manufacturer Part#	Digi-Key#
Resistor 2.1k 1% 1/10 W 0603	R2	1	2.10k	Rohm	MCR03EZPFX2101	RHM2.10KHCT-ND
Resistor 402 1% 1/10 W 0603	R5	1	402	Yageo	RC0603FR-07402RL	311-402HRTR-ND
Resistor 7.50k 1% 1/10 W 0603	R6, R7, R22	3	7.50k	Yageo	RC0603FR-077K5L	311-7.50KHRTR-ND
Resistor 330 Ohm 1% 1/10 W 0603	R8	1	330	Rohm	MCR03EZPFX3300	RHM330HCT-ND
Resistor 20.0 k 1% 1/10 W 0603	R9, R11	2	20.0k	Yageo	RC0603FR-0720KL	311-20.0KHRCT-ND
Resistor 2.0k 1% 1/10 W 0603	R10	1	2.0k	Yageo	RC0603FR-072KL	311-2.00KHRCT-ND
Resistor 22.1 1% 1/10 W 0603	R14	1	22.1	Yageo	RC0603FR-0722R1L	311-22.1HRCT-ND
Resistor 10.0k 1% 1/10 W 0603	R15, R17, R18, R28, R29, R30, R31, R33	8	10.0k	Yageo	RC0603FR-0710KL	311-10.0KHRTR-ND
Resistor 4.02k 1% 1/10W 0603	R16	1	4.02k	Yageo	RC0603FR-072K02L	311-4.02KHRTR-ND
Resistor 37.4k 1% 1/10 W 0603	R19, R20	2	37.4k	Yageo	RC0603FR-0737K4L	311-37.4KHRCT-ND
Resistor 3.83k 1% 1/10 W 0603	R21	1	3.83k	Yageo	RC0603FR-073K83L	311-3.83KHRCT-ND
Resistor 4.99 1% 1/10 W 0603	R23	1	4.99	Yageo	RC0603FR-074R99L	311-4.99HRCT-ND
Resistor 36.5 1% 1/10 W 0603	R26	1	36.5	Yageo	RC0603FR-0736R5L	311-36.5HRCT-ND
Resistor 41.2 1% 1/10 W 0603	R27	1	41.2	Yageo	RC0603FR-0741R2L	311-41.2HRCT-ND
750 k 1% Resistor 1206	R32	1	750k, 1%	Yageo	RC1206FR-07750KL	311-750KFRCT-ND
820 k 1% Resistor 1206	R34	1	820k, 1%	Yageo	RC1206FR-07820KL	311-820KFRCT-ND
3.9 Ohm 1% Resistor 0805	R35	1	3.9	Yageo	RC0805FR-073R9L	311-3.90CRCT-ND
RES 68.0 K OHM 1/8W 1% 0805 SMD	R36	1	68k, 1%	Yageo	RC0805FR-0768KL	311-68.0KCRTR-ND
RES 1.00 OHM 1/10W 1% 0603 SMD	R37	1	1.0	Yageo	RC0603FR-071RL	311-1.00HRCT-ND

Description	Designator	Quantity	Value	Manufacturer	Manufacturer Part#	Digi-Key#
RES 100 k OHM 1/10W 1% 0603 SMD	R38	1	100k	Yageo	RC0603FR-07100KL	311-100KHRTR-ND
RES 12.0 K OHM 1/10W 1% 0603 SMD	R39	1	12k, 1%	Yageo	RC0603FR-0712KL	311-12.0KHRCT-ND
6.8k, 1% Resistor 0603	R40	1	6.8k, 1%	Yageo	RC0603FR-076K8L	311-6.80KHRTR-ND
RESISTOR 10.0 OHM 5W 5% WIREWND	R41	1	10, 5W	Vishay	AC05000001009JAC00	PPC5W10.0CT-ND
Potentiometer	R46, R47	2		Bourns Inc	3352T-1-103LF	3352T-103LF-ND
Resistor 1.0 K, SMT	R48, R49, R50, R51, R61, R62, R63, R64, R65	9	1K	Panasonic	ERJ-6GEYJ102V	P1.0KACT-ND
Resistor 56 Ohm, SMT	R57, R58, R59, R60	4	56			P56ACT-ND
Switich, SPST	S2, S4	2		Omron	B3F-1022	SW403-ND
4009 Series DIP Switch, Raised actuator	S3	1		ESwitch	KAJ08LAGT	EG4441-ND
Isolation Transformer	T1	1		Precision Components	0505-0821G	
Power Trasnformer EE-16	T2	1	3.2mH	Shenzen Goldenway	EE-16 (5+5) (rev-A)	
	T2 (2nd Source)	1		Renco Electronics	RLCY-1014	
24 mH Common Mode Choke	T3	1	24mH	Shenzen Goldenway	EE8.3(2+2)-hori, (rev-A)	
	T3 (2nd Source)	1		Renco Electronics	RLCY-1013	
Simple Test point	TP1, TP2, TP3, TP4	4				5006K-ND
CY8CPLC20 OCD Part	U1	1		Cypress	CY8CPLC20-OCD	
Op-Amp 190 MHz	U2, U3, U4	3		National Semiconductor	LMH6639MF/NOPB	LMH6639MFCT-ND
Voltage Regulator 5 V	U5	1		ST Micro	LD1117DT50CTR	497-1237-1-ND
Off-Line Switcher	U6	1		iWatt	iW1690-07	

Description	Designator	Quantity	Value	Manufacturer	Manufacturer Part#	Digi-Key#
RS-232 transceiver (1.0 μ F Caps)	U8	1			MAX3232ECDR	296-19851-2-ND
Oscillator	Y1	1	24.00 MHz	Crystek	C3290-24.000	C3290-24.000-ND
	Y1 (2nd Source)			Citizen	CSX750FCC24. 000M-UT	300-7214-2-ND
Crystal 32.768 kHz 12.5 pF	Y2	1	32.768 kHz	ECS Inc.	ECS-3X8X	X1123-ND
LCD Module	LCD1	1		Cypress Semiconduc- tor	1187-00003	