

HFBR-0600Z Series

SERCOS Fiber Optic Transmitters and Receivers

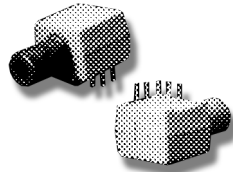

Data Sheet



SERCOS

SERCOS is a Serial Realtime COmmunication System, a standard digital interface for communication between controls and drives for numerically controlled machines. The SERCOS interface specification was written by a joint working group of the VDW (German Machine Tool Builders Association) and ZVEI (German Electrical and Electronic Manufacturer's Association) to allow data exchange between NC controls and drives via fiber optic rings, with isolation and noise immunity. The HFBR-0600Z family of fiber optic transmitters and receivers comply to the SERCOS specifications for transmitter and receiver optical characteristics and connector style (SMA).

Description

The HFBR-0600Z components are capable of operation at symbol rates from DC to over 2 MBd and distances from 0 to over 20 metres. The HFBR-1602Z and HFBR-1604Z transmitters contain a 655-nm AlGaAs emitter capable of efficiently launching optical power into 1000 nm plastic optical fiber. The optical output is specified at the end of 0.5 m of plastic optical fiber.

The HFBR-1604Z is a selected version of the HFBR-1602, with power specified to meet the SERCOS high attenuation specifications.

The HFBR-2602Z receiver incorporates an integrated photo IC containing a photodetector and dc amplifier driving an open-collector Schottky output transistor. The HFBR-2602Z is designed for direct interfacing to popular logic families. The absence of an internal pull-up resistor allows the open-collector output to be used with logic families such as CMOS requiring voltage excursions higher than V_{CC} . The HFBR-2602Z has a dynamic range of 15 dB.

Features

- Fully compliant to SERCOS optical specifications
- Optimized for 1 mm plastic optical fiber
- Compatible with SMA connectors
- Auto-insertable and wave solderable
- Data transmission at symbol rates from dc to over 2 MBd for distances from 0 to over 20 metres

Applications

- Industrial control data links
- Reduction of lightning and voltage transient susceptibility
- Tempest-secure data processing equipment
- Isolation in test and measurement instruments
- Robotics communication

CAUTION: The small junction sizes inherent to the design of this component increase the component's susceptibility to damage from electrostatic discharge (ESD). It is advised that normal static precautions be taken in handling and assembly of this component to prevent damage and/or degradation which may be induced by ESD.

HFBR-160XZ Transmitters

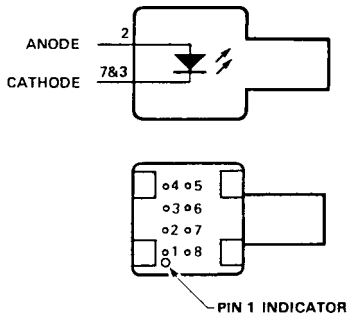

Pin	Function
1*	N.C.
2	ANODE
3	CATHODE
4*	N.C.
5*	N.C.
6	N.C.
7**	CATHODE
8*	N.C.

HFBR-2602Z Receiver

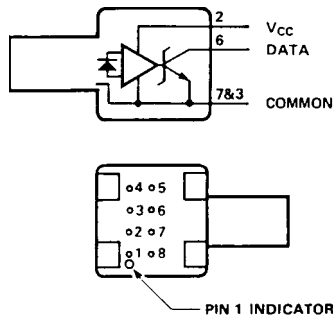

Pin	Function
1*	N.C.
2	V _{CC} (5 V)
3	COMMON
4*	N.C.
5*	N.C.
6	DATA
7	COMMON
8*	N.C.

* Pins 1, 4, 5, and 8 are isolated from the internal circuitry, but electrically connected to one another.

** Transmitter Pin 7 may be left unconnected if necessary.

In the receiver, both the open-collector "Data" output Pin 6 and V_{CC} Pin 2 are referenced to "Common" Pin 3 and 7. It is essential that a bypass capacitor (0.1 μF ceramic) be connected from Pin 2 (V_{CC}) to Pin 3 (circuit common) of the receiver.

SMA is an industry standard fiber optic connector, available from many fiber optic connector suppliers. HFBR-4401Z is a kit consisting of 100 nuts and 100 washers for panel mounting the HFBR-0600Z components.

HFBR-0600Z SMA Series Mechanical Dimensions

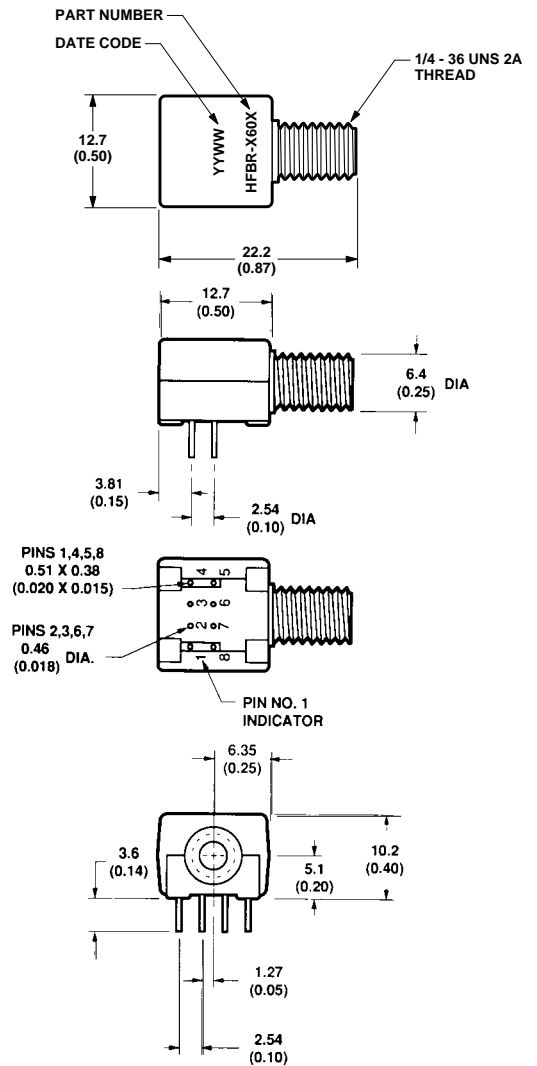

HFBR-1602Z/1604Z Transmitters

Absolute Maximum Ratings

Parameter	Symbol	Min.	Max.	Unit	Reference
Storage Temperature	T_S	-55	85	°C	
Operating Temperature	T_A	-40	85	°C	
Lead Soldering Cycle	Temp.		260	°C	Note 1
	Time		10	s	Note 1
Forward Input Current Peak	I_{FPK}		120	mA	
Forward Input Current Average	I_{Favg}		60	mA	
Reverse Input Voltage	V_{BR}		-5	V	

Electrical/Optical Characteristics 0 to 55°C, unless otherwise stated.

Parameter	Symbol	Min.	Typ. ^[2]	Max.	Unit	Condition	Reference
Forward Voltage	V_F	1.5	1.9	2.2	V	$I_F = 35 \text{ mA}$	
Forward Voltage Temp. Coefficient	$\Delta V_F / \Delta T$		-1.2		mV/°C	$I_F = 35 \text{ mA}$	
Reverse Input Voltage	V_{BR}	-5.0	-18		V	$I_R = 100 \mu\text{A}$	
Peak Emission Wavelength	λ_P	640	655	675	nm		
Full Width Half Maximum	FWHM		20	30	nm	25°C	
Diode Capacitance	C_T		30		pF	$V_F = 0$ $f = 1 \text{ MHz}$	
Optical Power Temp. Coefficient	$\Delta P_T / \Delta T$		-0.01		dBm/°C	$I_F = 35 \text{ mA}$	
Thermal Resistance	θ_{JA}		330		°C/W		Notes 3, 4
Peak Optical Output Power of HFBR-1602Z	P_{T1602}	-10.5		-5.5	dBm	$I_F = 35 \text{ mA}$	Notes 5, 6, 11
Peak Optical Output Power of HFBR-1604Z	P_{T1604}	-7.5 -10.5		-3.5 -5.5	dBm dBm	$I_F = 60 \text{ mA}$ $I_F = 35 \text{ mA}$	Notes 5, 6, 11
Rise Time (10% to 90%)	t_r		57		ns	$I_F = 60 \text{ mA}$ $I_F = 35 \text{ mA}$	
			50		ns		
Fall Time (90% to 10%)	t_f		40		ns	$I_F = 60 \text{ mA}$ $I_F = 35 \text{ mA}$	
			27		ns		

HFBR-2602Z Receiver

Absolute Maximum Ratings

Parameter	Symbol	Min.	Max.	Unit	Reference
Storage Temperature	T_S	-55	85	°C	
Operating Temperature	T_A	-40	85	°C	
Lead Soldering Cycle	Temp.		260	°C	Note 1
	Time		10	s	Note 1
Supply Voltage	V_{CC}	-0.5	7.0	V	
Output Current	I_O		25	mA	
Output Voltage	V_O	-0.5	18.0	V	
Output Collector Power Dissipation	P_{OAVG}		40	mW	
Fan Out (TTL)	N		5		Note 8

Electrical/Optical Characteristics 0 to 55°C;

Fiber core diameter ≤ 1.0 mm, fiber N.A. ≤ 0.5 , $4.75 \text{ V} \leq V_{CC} \leq 5.25 \text{ V}$

Parameter	Symbol	Min.	Typ. ^[2]	Max.	Unit	Condition	Reference
High Level Output Current	I_{OH}		5	250	μA	$V_{OH} = 18 \text{ V}$ $P_R < -31.2 \text{ dBm}$	
Low Level Output Voltage	V_{OL}		0.4	0.5	V	$I_{OL} = 8 \text{ mA}$ $P_R > -20.0 \text{ dBm}$	
High Level Supply Current	I_{CCH}		3.5	6.3	mA	$V_{CC} = 5.25 \text{ V}$ $P_R < -31.2 \text{ dBm}$	
Low Level Supply Current	I_{CCL}		6.2	10	mA	$V_{CC} = 5.25 \text{ V}$ $P_R > -20.0 \text{ dBm}$	

Dynamic Characteristics 0 to 55°C unless otherwise specified; $4.75 \text{ V} \leq V_{CC} \leq 5.25 \text{ V}$; BER $\leq 10^{-9}$

Parameter	Symbol	Min.	Typ. ^[2]	Max.	Unit	Condition	Reference
Peak Input Power Level Logic HIGH	P_{RH}			-31.2	dBm	$\lambda_p = 655 \text{ nm}$	Note 7
Peak Input Power Level Logic LOW	P_{RL}	-20.0		-5.0	dBm	$I_{OL} = 8 \text{ mA}$	Note 7
Propagation Delay LOW to HIGH	t_{PLH}		60		ns	$P_R = -20 \text{ dBm}$ 2 MBd	Note 8, 9
Propagation Delay HIGH to LOW	t_{PHL}		110		ns	$P_R = -20 \text{ dBm}$ 2 MBd	Note 8, 9
Pulse Width Distortion, $t_{PLH} - t_{PHL}$	PWD		50		ns	$P_R = -5 \text{ dBm}$	Note 10 Figure 6
			-50		ns	$P_R = -20 \text{ dBm}$	

Notes:

- 2.0 mm from where leads enter case.
- Typical data at $T_A = +25^\circ\text{C}$.
- Thermal resistance is measured with the transmitter coupled to a connector assembly and fiber, and mounted on a printed circuit board.
- Pins 2, 6, and 7 are welded to the cathode header connection to minimize the thermal resistance from junction to ambient. To further reduce the thermal resistance, the cathode trace should be made as large as is consistent with good RF circuit design.
- P_T is measured with a large area detector at the end of 0.5 metre of plastic optical fiber with 1 mm diameter and numerical aperture of 0.5.

- When changing μW to dBm, the optical power is referenced to 1 mW (1000 μW).
Optical Power P(dBm) = $10 \log [P (\mu\text{W}) / 1000 \mu\text{W}]$.
- Measured at the end of 1mm plastic fiber optic cable with a large area detector.
- 8 mA load (5 x 1.6 mA), $R_L = 560 \Omega$.
- Propagation delay through the system is the result of several sequentially occurring phenomena. Consequently it is a combination of data-rate-limiting effects and of transmission-time effects. Because of this, the data-rate limit of the system must be described in terms of time differentials between delays imposed on falling and rising edges. As the cable

length is increased, the propagation delays increase. Data-rate, as limited by pulse width distortion, is not affected by increasing cable length if the optical power level at the receiver is maintained.

- Pulse width distortion is the difference between the delay of the rising and falling edges.
- Both HFBR-1602Z and HFBR-1604Z meet the SERCOS "low attenuation" specifications when operated at 35 mA; only HFBR-1604Z meets the SERCOS "high attenuation" limits when operated at 60 mA.

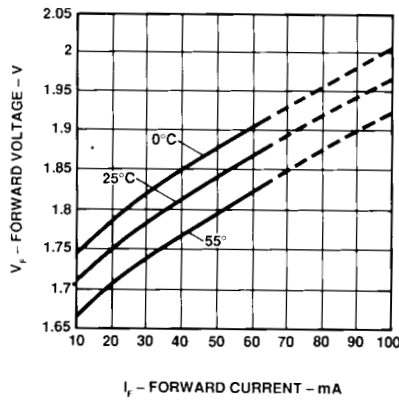

Figure 1. Forward voltage and current characteristics.

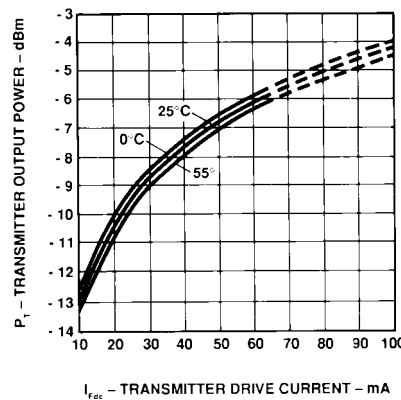

Figure 2. Typical transmitter output vs. forward current.

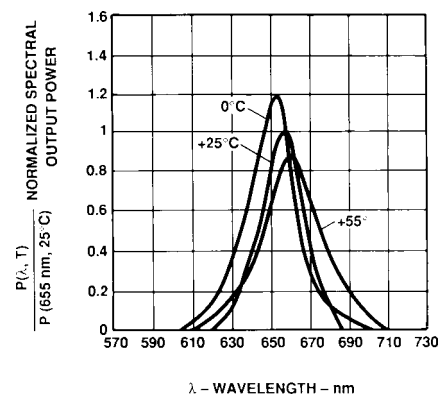

Figure 3. Transmitter spectrum normalized to the peak at 25°C.

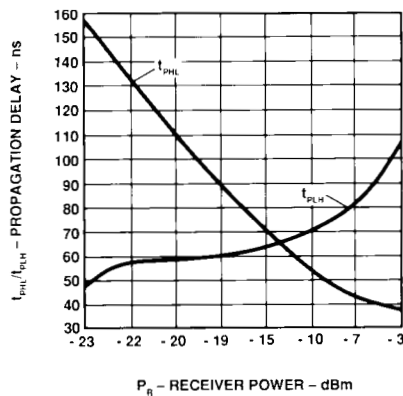

Figure 4. Typical propagation delay through system with 0.5 metre of cable.

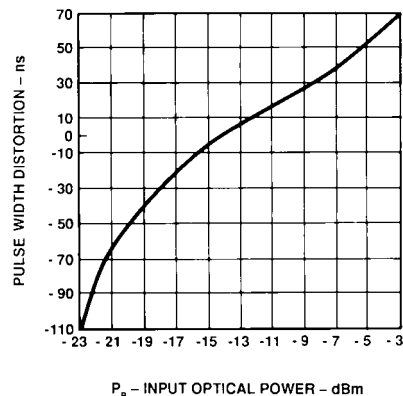

Figure 5. Typical HFBR-160XZ/2602Z link pulsewidth distortion vs. optical power.

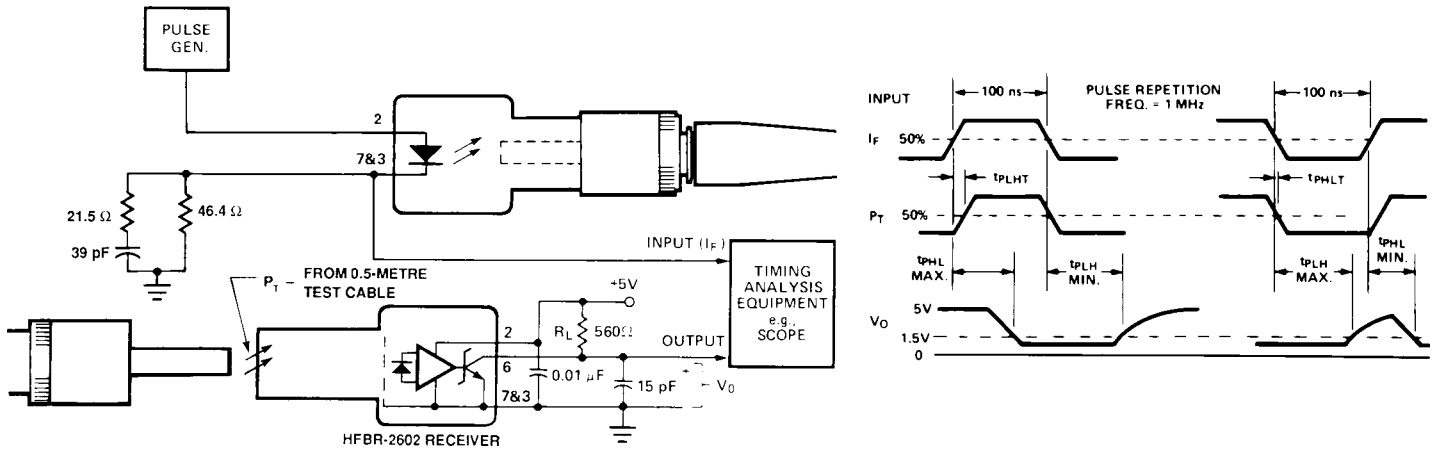

Figure 6. System propagation delay test circuit and waveform timing definitions.

For product information and a complete list of distributors, please go to our website: www.avagotech.com

Avago, Avago Technologies, and the A logo are trademarks of Avago Technologies Limited in the United States and other countries. Data subject to change. Copyright © 2007 Avago Technologies Limited. All rights reserved. 5989-4798EN October 29, 2007

