



# MACROMATIC

## Industrial Control & Monitoring Products



Alternating Relays

Time Delay Relays

Phase Monitor Relays

Voltage Monitor Relays

Current Monitor Relays



## Your Choice for Industrial Controls

For 30 years, Macromatic has been producing industrial control & monitoring products. All are engineered and manufactured in our U.S.-based facility in Menomonee Falls, Wisconsin (a Milwaukee suburb), utilizing a time-proven quality system to produce products that consistently meet your requirements for function, availability & value.

### ***Who Uses Our Controls?***

A wide variety of challenges can be met by using our products. Our customer base includes OEM's who specify Macromatic controls in their equipment, and end users who count on Macromatic precision and reliability for their own applications. Our products are used in a variety of industries such as machine tool, automotive, material handling, pulp & paper, food & beverage, transportation, communications, water/wastewater and HVAC, among many.

### ***Where to Buy?***

We are pleased to offer our complete line of products in the United States and Canada through a network of Preferred Macromatic Distributors. We have partners with national, regional and local presence who stock and sell our products. Call us or visit us on the web to locate a distributor or sales representative near you.

### ***Need Technical Help? Have Special Applications?***

Do you need help selecting or applying one of our products? Don't quite know what you need? Our team of engineers and technical advisors is available to help you address your specific needs. Whether by helping you decide which time delay relay function is required in your application or working with you on designing custom-engineered solutions for your particular need, we have the experience to help you one-on-one. Don't hesitate to call us to discuss your particular application.

### ***Why Choose Macromatic Controls?***

Long known for their precision and reliability, Macromatic products are increasingly the choice of industrial design engineers for use in new equipment and are preferred by maintenance personnel as quality replacements in existing applications. We test each product twice before it is shipped, and all products have an extensive warranty period longer



than most other manufacturers (contact Macromatic for further details). Most standard and custom design products are UL recognized or listed and CSA approved. We have obtained UL Listing on our plug-in products when used with our sockets. Many products now carry the CE Mark.

### ***What You Need, When You Need It***

Don't wait for something you need now. Macromatic offers prompt delivery of standard products and can even deliver many non-standard orders within seven to ten days, all without any special expediting fees charged by many manufacturers. We are dedicated to being responsive, and that means you get what you need when you need it, not weeks or months from now. Contact us or one of our Preferred Distributors or Sales Representatives and we will provide you with an on-time solution.

### ***Want to Learn More?***

You can reach us at 800-238-7474 or e-mail us at [whats-up@macromatic.com](mailto:whats-up@macromatic.com). Our customer service and technical assistance people are ready to help with your questions or special needs. Or you can visit us at [www.macromatic.com](http://www.macromatic.com).



## Product Index

---

<b>Index by Product Number</b> .....	4
<b>Phase Monitor Relays</b>	
Product Summary .....	5
PCP Series Phase Reversal .....	6-7
PLP Series Phase Loss & Phase Reversal .....	8-9
PAP Series Phase Loss, Phase Reversal & Undervoltage .....	10-11
PMP Series Phase Loss, Phase Reversal, Phase Unbalance, Undervoltage & Overvoltage .....	12-13
PMD Series Phase Loss, Phase Reversal, Phase Unbalance, Undervoltage & Overvoltage .....	14-15
<b>Current Monitor Relays <i>NEW</i></b>	
Product Summary .....	17
CM Series Standard .....	18-19
CO Series Overcurrent .....	20-21
CU Series Undercurrent .....	22-23
<b>Voltage Monitor Relays <i>NEW</i></b>	
Product Summary .....	24
VM Series Over/Under Voltage (Fixed Time Delay on Drop-Out) .....	25, 27
VA Series Over/Under Voltage (Adjustable Time Delay on Drop-Out) .....	26-27
VW Series Voltage Band (Window) .....	28-29
<b>Time Delay Relays</b>	
Product Summary .....	30-31
Definition of Timing Functions .....	32-33
TR-5 Series Non-Programmable DPDT .....	34-37
TR-5 Series Non-Programmable 8 Pin SPDT .....	38-39
TR-6 Series <i>Time Ranger</i> Programmable Multi-Range .....	40-43
SS-6 & -8 Series Compact Non-Programmable .....	44
SS-4 Series Non-Programmable with Quick Connect Terminals .....	45
TD-7 Series <i>Time Ranger</i> Digital-Set Programmable .....	46-47
981 Series <i>Time Ranger III</i> Digital-Set Multi-Function Multi-Range .....	48-49
Standard Modifications .....	50-51
<b>Alternating Relays</b>	
For 1 Switch Applications (SPDT& DPDT) .....	52-53
For 2 Switch Applications (DPDT Cross-Wired) .....	54-55
For 3 Switch Applications .....	56-57
<b>Sockets &amp; Accessories</b> .....	16 & 58

---

Since we continuously strive to improve and update our product offering, specifications are subject to change without notice.

“Macromatic” & “Time Ranger” are Registered Tradenames of Macromatic Controls LLC

# Index By Product Number

Product *	Page	Product *	Page	Product *	Page	Product *	Page	Product *	Page
70100	16 & 58	COKP05A28	20	SS-40228-xx	45	TR-51621-xx	35	TR-61628	41
70166	16 & 58	COKP05A62	20	SS-41622-xx	45	TR-51622-xx	35	TR-61721	41
70169-D	16 & 58	COKP05A68	20	SS-41628-xx	45	TR-51626-xx	35	TR-61722	41
70170-D	16 & 58	COKP10A22	20	SS-6262-xx	44	TR-51628-xx	35	TR-61726	41
70171-D	16 & 58	COKP10A28	20	SS-6266-xx	44	TR-51661-xx	38	TR-61728	41
70200	16 & 58	COKP10A62	20	SS-6268-xx	44	TR-51662-xx	38	TR-61821	41
70300	48	COKP10A68	20	SS-70166	***	TR-51666-xx	38	TR-61822	41
70310	48	COP01A22	20	SS-8062-xx	44	TR-51668-xx	38	TR-61826	41
70320	48	COP01A28	20	SS-8066-xx	44	TR-51721-xx	35	TR-61828	41
9816U1	48	COP01A62	20	SS-8068-xx	44	TR-51722-xx	35	TR-61921	41
ARP012A2	52	COP01A68	20	SS-8162-xx	**	TR-51726-xx	35	TR-61922	41
ARP012A2R	52	COP05A22	20	SS-8166-xx	**	TR-51728-xx	35	TR-61926	41
ARP012A3	54	COP05A28	20	SS-8168-xx	**	TR-51761-xx	38	TR-61928	41
ARP012A3R	54	COP05A62	20	SS-8562-xx	44	TR-51762-xx	38	TR-63121	42
ARP012A6	52	COP05A68	20	SS-8566-xx	44	TR-51766-xx	38	TR-63122	42
ARP012A6R	52	COP10A22	20	SS-8568-xx	44	TR-51768-xx	38	TR-63126	42
ARP012A8	56	COP10A28	20	SS-8762-xx	44	TR-51821-xx	35	TR-63128	42
ARP012A8R	56	COP10A62	20	SS-8766-xx	44	TR-51822-xx	35	TR-65121	42
ARP024A2	52	COP10A68	20	SS-8768-xx	44	TR-51826-xx	35	TR-65122	42
ARP024A2R	52	CUP01A22	22	TD-70221	46	TR-51828-xx	35	TR-65126	42
ARP024A3	54	CUP01A28	22	TD-70222	46	TR-51861-xx	38	TR-65128	42
ARP024A3R	54	CUP01A62	22	TD-70226	46	TR-51862-xx	38	TR-66121	42
ARP024A6	52	CUP01A68	22	TD-70228	46	TR-51866-xx	38	TR-66122	42
ARP024A6R	52	CUP05A22	22	TD-70521	46	TR-51868-xx	38	TR-66126	42
ARP024A8	56	CUP05A28	22	TD-70522	46	TR-51921-xx	35	TR-66128	42
ARP024A8R	56	CUP05A62	22	TD-70526	46	TR-51922-xx	35	TR-66521	42
ARP120A2	52	CUP05A68	22	TD-70528	46	TR-51926-xx	35	TR-66522	42
ARP120A2R	52	CUP10A22	22	TD-70821	46	TR-51928-xx	35	TR-66526	42
ARP120A3	54	CUP10A28	22	TD-70822	46	TR-51961-xx	38	TR-66528	42
ARP120A3R	54	CUP10A62	22	TD-70826	46	TR-51962-xx	38	TR-68129	**
ARP120A6	52	CUP10A68	22	TD-70828	46	TR-51966-xx	38	TR-68169	**
ARP120A6R	52	PAP120	10	TD-71521	46	TR-51968-xx	38	VAKP012D	26
ARP120A8	56	PAP208	10	TD-71522	46	TR-53121-xx	36	VAKP024A	26
ARP120A8R	56	PAP240	10	TD-71526	46	TR-53122-xx	36	VAKP024D	26
ARP240A2	52	PAP400	10	TD-71528	46	TR-53126-xx	36	VAKP048D	26
ARP240A2R	52	PAP480	10	TD-71621	46	TR-53128-xx	36	VAKP110D	26
ARP240A3	54	PCP1	6	TD-71622	46	TR-55121-xx	36	VAKP120A	26
ARP240A3R	54	PCP2	6	TD-71626	46	TR-55122-xx	36	VAP012D	26
ARP240A6	52	PLP120	8	TD-71628	46	TR-55126-xx	36	VAP024A	26
ARP240A6R	52	PLP208	8	TD-78121	46	TR-55128-xx	36	VAP024D	26
ARP240A8	56	PLP240	8	TD-78122	46	TR-56121-xx	36	VAP048D	26
ARP240A8R	56	PLP400	8	TD-78126	46	TR-56122-xx	36	VAP110D	26
CMKP01A22	18	PLP480	8	TD-78128	46	TR-56126-xx	36	VAP120A	26
CMKP01A28	18	PMD120	14	TR-50221-xx	34	TR-56128-xx	36	VMKP012D	25
CMKP01A62	18	PMD208	**	TR-50222-xx	34	TR-56521-xx	36	VMKP024A	25
CMKP01A68	18	PMD240	**	TR-50226-xx	34	TR-56522-xx	36	VMKP024D	25
CMKP05A22	18	PMD400	**	TR-50228-xx	34	TR-56526-xx	36	VMKP048D	25
CMKP05A28	18	PMD480	**	TR-50521-xx	34	TR-56528-xx	36	VMKP110D	25
CMKP05A62	18	PMD600	14	TR-50522-xx	34	TR-60221	40	VMKP120A	25
CMKP05A68	18	PMDU	14	TR-50526-xx	34	TR-60222	40	VMP012D	25
CMKP10A22	18	PMP120	12	TR-50528-xx	34	TR-60226	40	VMP024A	25
CMKP10A28	18	PMP208	**	TR-50821-xx	34	TR-60228	40	VMP024D	25
CMKP10A62	18	PMP240	**	TR-50822-xx	34	TR-60521	40	VMP048D	25
CMKP10A68	18	PMP480	**	TR-50826-xx	34	TR-60522	40	VMP110D	25
CMP01A22	18	PMPU	12	TR-50828-xx	34	TR-60526	40	VMP120A	25
CMP01A28	18	SS-3062-xx	**	TR-51321-xx	35	TR-60528	40	VWKP012D	28
CMP01A62	18	SS-3066-xx	**	TR-51322-xx	35	TR-60821	40	VWKP024A	28
CMP01A68	18	SS-3068-xx	**	TR-51326-xx	35	TR-60822	40	VWKP024D	28
CMP05A22	18	SS-3162-xx	**	TR-51328-xx	35	TR-60826	40	VWKP048D	28
CMP05A28	18	SS-3166-xx	**	TR-51361-xx	38	TR-60828	40	VWKP110D	28
CMP05A62	18	SS-3168-xx	**	TR-51362-xx	38	TR-61321	41	VWKP120A	28
CMP05A68	18	SS-3262-xx	**	TR-51366-xx	38	TR-61322	41	VWP012D	28
CMP10A22	18	SS-3266-xx	**	TR-51368-xx	38	TR-61326	41	VWP024A	28
CMP10A28	18	SS-3268-xx	**	TR-51521-xx	35	TR-61328	41	VWP024D	28
CMP10A62	18	SS-3362-xx	**	TR-51522-xx	35	TR-61521	41	VWP048D	28
CMP10A68	18	SS-3366-xx	**	TR-51526-xx	35	TR-61522	41	VWP110D	28
COKP01A22	20	SS-3368-xx	**	TR-51528-xx	35	TR-61526	41	VWP120A	28
COKP01A28	20	SS-3562-xx	**	TR-51561-xx	38	TR-61528	41		
COKP01A62	20	SS-3566-xx	**	TR-51562-xx	38	TR-61621	41		
COKP01A68	20	SS-3568-xx	**	TR-51566-xx	38	TR-61622	41		
COKP05A22	20	SS-40222-xx	45	TR-51568-xx	38	TR-61626	41		

\* The "-xx" suffix denotes the time range for non-programmable time delay relays.

\*\* Contact Macromatic for more information.

# PHASE MONITOR RELAYS

## Product Summary



Phase Monitor Relays provide protection against premature equipment failure caused by voltage faults on 3 Phase systems. All Macromatic Phase Monitor Relays are designed to be compatible with most Wye or Delta systems. In Wye systems, a connection to a neutral is not required. Phase Monitor Relays protect against single phasing regardless of any regenerative voltages.

The Reference Guide below provides general information on the different versions of Phase Monitor Relays offered by Macromatic (see Product Selection on the following pages for further details):

Series	Mounting Style	Phase Loss	Phase Reversal	Phase Unbalance	Under Voltage	Over Voltage	Time Delay on Undervoltage	Approvals *	See Page
PCP	Plug-in *		P					C  US	6
PLP	Plug-in *	P	P					C  US	8
PAP	Plug-in *	P	P		P (adj.)		50ms fixed	C  US	10
PMP	Plug-in *	P	P	P	P (adj.)	P (fixed)	0.1 - 20 sec.	C  US	12
PMD	Surface	P	P	P	P (adj.)	P (fixed)	0.1 - 20 sec.	C  US	14

\* In addition to the above approvals, all Plug-in Products are also UL Listed when used with the appropriate Macromatic socket.

### Protection

Depending on the unit selected, it will protect three phase equipment against:

- u **phase loss** - total loss of one or more of the three phases. Also known as "single phasing." Typically caused by a blown fuse, broken wire, or worn contact. This condition would result in a motor drawing locked rotor current during start-up. In addition, a three phase motor will continue to run after losing a phase, resulting in possible motor burn-out.
- u **phase reversal** - reversing any two of the three phases will cause a three phase motor to run in the opposite direction. This may cause damage to driven machinery or injury to personnel. The condition usually occurs as a result of mistakes made during routine maintenance or when modifications are made to the circuit.
- u **phase unbalance** - unbalance of a three phase system occurs when single phase loads are connected such that one or two of the lines (phases) carry more or less of the load. This could cause motors to run at temperatures above published ratings.
- u **undervoltage** - when voltage in all three lines of a three phase system drop simultaneously.
- u **overvoltage** - when voltage in all three lines of a three phase system increase simultaneously.

### Typical Connections

#### Line Side Monitoring

With the relay connected before the motor starter, the motor can be started in the reverse direction. However, the motor is unprotected against phase failures between the relay and the motor.

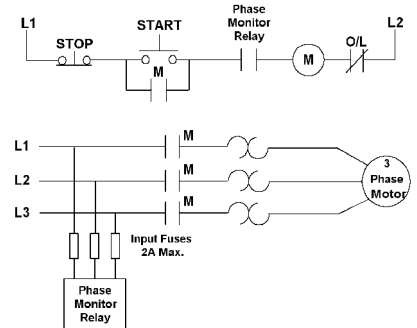

#### Load Side Monitoring

With the relay connected directly to the motor, the total feed lines are monitored. This connection should not be used with reversing motors.

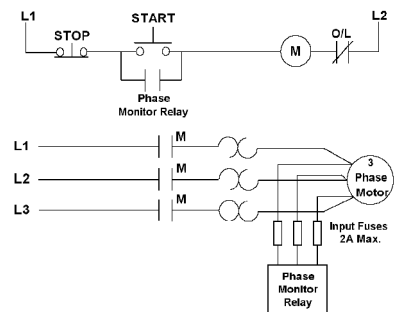

# PHASE MONITOR RELAYS

Phase Reversal Only  
PCP Series Plug-in



- u Protects against phase reversal
- u One version works on 208-480V 3 Phase Systems
- u LED indicates both normal and fault conditions
- u Compact plug-in case utilizing industry-standard 8 pin octal socket
- u 10A SPDT output contacts

u   LISTED  
(with appropriate socket)

The PCP Series Phase Monitor Relays provide protection against phase reversal in a compact plug-in design. One version will work on any 3 phase system from 208V to 480V (a separate 120V-only version is also available). These devices are designed to be compatible with most Wye or Delta systems. In Wye systems, a connection to a neutral is not required.

The relay is energized and the LED on when the sequence is correct. Any fault will de-energize the relay and turn off the LED. Re-energization is automatic upon correction of the fault condition.

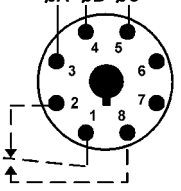
MOUNTING STYLE	NOMINAL VOLTAGE 50/60 Hz	PRODUCT NUMBER	WIRING/SOCKETn
Plug-in	120V	PCP1	8 Pin Octal <b>70169-D</b> $\phi A$ $\phi B$ $\phi C$  DIAGRAM 23
	208-480V	PCP2 *	

\* Requires a 600V-rated socket when used on system voltages greater than 300V.  
n See Page 16 for **Sockets & Accessories**



**800-238-7474**

[www.macromatic.com](http://www.macromatic.com)  
[whats-up@macromatic.com](mailto:whats-up@macromatic.com)

# PHASE MONITOR RELAYS

Phase Reversal Only  
PCP Series Plug-in  
Application Data & Dimensions

## Application Data

### **Phase Reversal:**

Unit trips if sequence of the three phases is anything other than A-B-C.

### **Output Contacts:**

10A SPDT @ 240V AC, 1/3HP @ 240V AC (N.O.), 1/6HP @ 240V AC (N.C.)

### **Life:**

Full Load: 100,000 operations

### **Response Times:**

Operate: 50ms

Release: 50ms

### **Load (Burden):**

3VA

### **Temperature:**

-28° to 65°C (-20° to 150°F)

### **Transient Protection:**

10,000 volts for 20 microseconds

### **Mounting:**

Uses an 8 pin octal socket. Requires a 600V-rated socket when used on system voltages greater than 300V (Macromatic Product Number 70169-D--see Page 16).

### **Indicator LED:**

Red LED on when all conditions are normal, and off when a fault condition has occurred.

### **Reset:**

Automatic upon correction of fault

### **Approvals:**



When used with Macromatic socket 70169-D rated 600V

## Dimensions

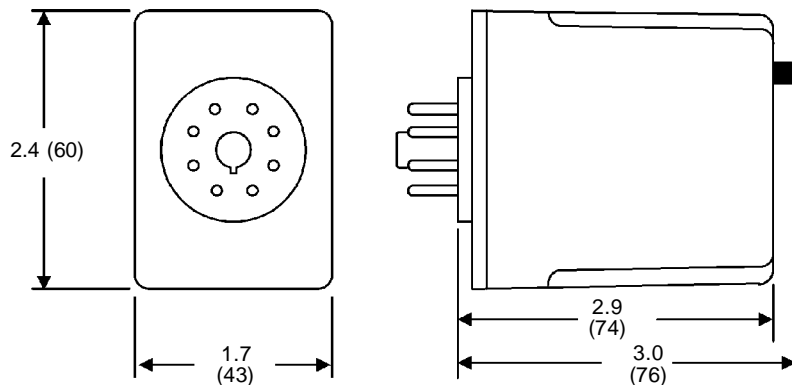

All Dimensions in  
Inches (Millimeters)

# PHASE MONITOR RELAYS

Phase Loss & Phase Reversal  
PLP Series Plug-in



- u Protects against phase loss & phase reversal
- u LED indicates both normal and fault conditions
- u Compact plug-in case utilizing industry-standard 8 pin octal socket
- u 10A SPDT output contacts



The PLP Series Phase Monitor Relays provide protection against phase loss & phase reversal in a compact plug-in design. These devices are designed to be compatible with most Wye or Delta systems. In Wye systems, a connection to a neutral is not required. Phase Monitor Relays protect against single phasing regardless of any regenerative voltages.

The relay is energized and the LED on when all three phases are present and in the correct sequence. Any fault will instantaneously de-energize the relay and turn off the LED. Re-energization is automatic upon correction of the fault condition.

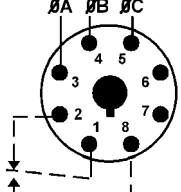
MOUNTING STYLE	NOMINAL VOLTAGE 50/60 Hz	PRODUCT NUMBER	WIRING/SOCKET <sup>n</sup>
Plug-in	120V	PLP120	8 Pin Octal <b>70169-D</b>  DIAGRAM 23
	208V	PLP208	
	240V	PLP240	
	400V	PLP400 *	
	480V	PLP480 *	

\* Requires a 600V-rated socket when used on system voltages greater than 300V.  
<sup>n</sup> See Page 16 for **Sockets & Accessories**



**800-238-7474**

[www.macromatic.com](http://www.macromatic.com)  
[whats-up@macromatic.com](mailto:whats-up@macromatic.com)



# PHASE MONITOR RELAYS

Phase Loss & Phase Reversal  
PLP Series Plug-in  
Application Data & Dimensions

## Application Data

### **Phase Loss:**

Unit trips on loss of any Phase A, B or C

### **Phase Reversal:**

Unit trips if sequence of the three phases is anything other than A-B-C.

### **Output Contacts:**

10A SPDT @ 240V AC, 1/3HP @ 240V AC (N.O.), 1/6HP @ 240V AC (N.C.)

### **Life:**

Full Load: 100,000 operations

### **Response Times:**

Operate: 50ms

Release: 50ms

### **Load (Burden):**

3VA

### **Temperature:**

-28° to 65°C (-20° to 150°F)

### **Transient Protection:**

10,000 volts for 20 microseconds

### **Mounting:**

Uses an 8 pin octal socket. Requires a 600V-rated socket when used on system voltages greater than 300V (Macromatic Product Number 70169-D--see Page 16).

### **Indicator LED:**

Red LED on when all conditions are normal, and off when a fault condition has occurred.

### **Reset:**

Automatic upon correction of fault

### **Approvals:**



When used with Macromatic socket 70169-D rated 600V

## Dimensions

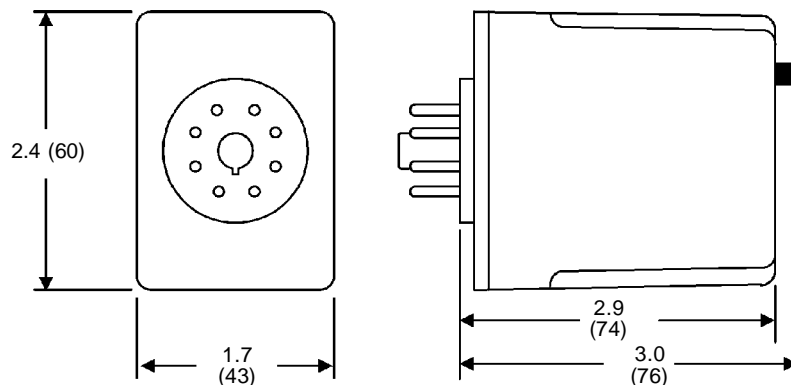

All Dimensions in  
Inches (Millimeters)

# PHASE MONITOR RELAYS

Phase Loss, Phase Reversal & Undervoltage  
PAP Series Plug-in



- u Protects against phase loss, phase reversal & undervoltage
- u Undervoltage setting is adjustable from 75-95% of nominal
- u LED indicates both normal and fault conditions
- u Compact plug-in case utilizing industry-standard 8 pin octal socket
- u 10A SPDT output contacts

u  LISTED  
(with appropriate socket)

The PAP Series Phase Monitor Relays provide protection against phase loss, phase reversal & undervoltage in a compact plug-in design. These devices are designed to be compatible with most Wye or Delta systems. In Wye systems, a connection to a neutral is not required. Phase Monitor Relays protect against single phasing regardless of any regenerative voltages.

The relay is energized and the LED on when all three phase are present in the correct sequence at a voltage level above the undervoltage setting. The undervoltage drop-out can be set at 75-95% of operating voltage. Any fault will instantaneously de-energize the relay and turn off the LED. Re-energization is automatic upon correction of the fault condition.

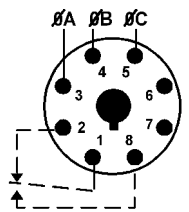
MOUNTING STYLE	NOMINAL VOLTAGE 60 Hz	UNDER-VOLTAGE RANGE	PRODUCT NUMBER	WIRING/ SOCKET <sup>n</sup>
Plug-in	120V	90-115V	PAP120	 <p>DIAGRAM 23</p>
	208V	156-198V	PAP208	
	240V	180-230V	PAP240	
	400V	300-380V	PAP400 *	
	480V	360-460V	PAP480 *	

\* Requires a 600V-rated socket when used on system voltages greater than 300V.  
n See Page 16 for **Sockets & Accessories**



800-238-7474

www.macromatic.com  
whats-up@macromatic.com

# PHASE MONITOR RELAYS

## Phase Loss, Phase Reversal & Undervoltage PAP Series Plug-in Application Data & Dimensions

### Application Data

**Phase Loss:**

Unit trips on loss of any Phase A, B or C

**Phase Reversal:**

Unit trips if sequence of the three phases is anything other than A-B-C.

**Undervoltage:**

Adjustable over a range per product selection table. Unit trips when the average of all three lines is less than the adjusted set point.

**Output Contacts:**

10A SPDT @ 240V AC, 1/3HP @ 240V AC (N.O.), 1/6HP @ 240V AC (N.C.)

**Life:**

Full Load: 100,000 operations

**Response Times:**

Operate: 50ms

Release: 50ms

**Load (Burden):**

3VA

**Temperature:**

-28° to 65°C (-20° to 150°F)

**Transient Protection:**

10,000 volts for 20 microseconds

**Mounting:**

Uses an 8 pin octal socket. Requires a 600V-rated socket when used on system voltages greater than 300V (Macromatic Product Number 70169-D--see Page 16).

**Indicator LED:**

Red LED on when all conditions are normal, and off when a fault condition has occurred.

**Reset:**

Automatic upon correction of fault

**Approvals:**

When used with Macromatic socket 70169-D rated 600V

### Dimensions

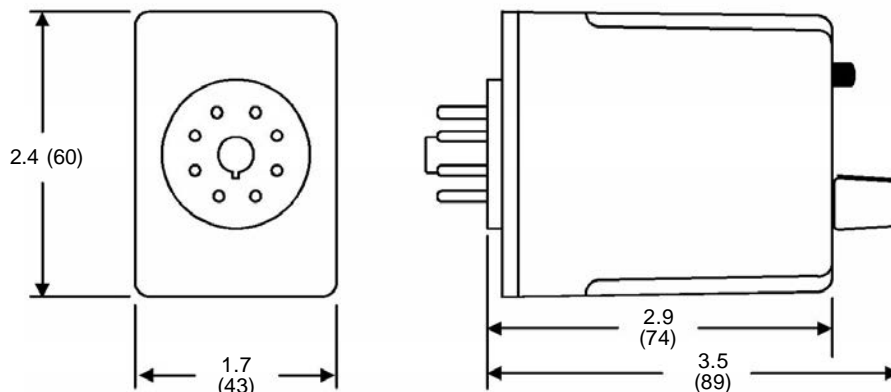

All Dimensions in  
Inches (Millimeters)

# PHASE MONITOR RELAYS

Phase Loss, Phase Reversal, Phase Unbalance, and Under/Over Voltage  
PMP Series Plug-in



- u Universal voltage range of 208-480V on PMPU provides the flexibility to cover a variety of applications with one unit
- u Protects against phase loss, phase reversal, phase unbalance, undervoltage and overvoltage
- u Variety of user-selectable and adjustable settings for the ultimate in three-phase protection
- u Automatic or Manual Reset
- u Multi-Color LED indicates normal condition and defines fault to simplify troubleshooting
- u Compact plug-in case utilizing industry-standard 8 pin octal socket
- u 10A SPDT output contacts



The PMP Series Phase Monitor Relays utilize a microprocessor-based design to provide protection against phase loss, phase reversal, phase unbalance, undervoltage and overvoltage. The PMPU is a universal voltage product that works on any three-phase system voltage from 208-480V (a separate 120V version is available). These devices are designed to be compatible with most Wye or Delta systems. In Wye systems, a connection to a neutral is not required. PMP Series products protect against unbalanced voltages or single phasing regardless of any regenerative voltages.

The relay is energized when the phase sequence and all voltages are correct. Any one of five fault conditions will de-energize the relay. As standard, re-energization is automatic upon correction of the fault condition. Manual reset is available if a momentary N.C. switch is wired to the appropriate terminals. A multi-color LED indicates normal condition and also provides specific fault indication to simplify troubleshooting.

The PMP Series offers a variety of user-adjustable settings. The percent phase unbalance is adjustable from 2-10%, and also has a "Disable" setting for those applications where poor voltage conditions could cause nuisance tripping. The undervoltage drop-out can be set at 80-95% of operating voltage (overvoltage setting is fixed at 110% of nominal). The adjustable time delay drop-out on undervoltage (0.1-20 seconds) eliminates nuisance tripping caused by momentary voltage fluctuations. There is also an adjustable time delay (1-300 seconds) on both power up and restart after a fault has been cleared.

MOUNTING STYLE	OPERATING VOLTAGE 50/60 Hz	PRODUCT NUMBER	WIRING/SOCKET n
Plug-in	120V	PMP120	8 Pin Octal <b>70169-D</b> DIAGRAM 104
	208-480V	PMPU *	

\* Requires a 600V-rated socket when used on system voltages greater than 300V.  
n See Page 16 for **Sockets & Accessories**



**800-238-7474**

[www.macromatic.com](http://www.macromatic.com)  
[whats-up@macromatic.com](mailto:whats-up@macromatic.com)

# PHASE MONITOR RELAYS

Phase Loss, Phase Reversal, Phase Unbalance, and Under/Over Voltage  
PMP Series Plug-in  
Application Data & Dimensions

## Application Data

### Phase Loss:

Unit trips on loss of any Phase A, B or C.

### Phase Reversal:

Unit trips if rotation (sequence) of the three phases is anything other than A-B-C.

### Undervoltage:

Adjustable from 80-95% of nominal voltage. Unit trips when the average of all three lines is less than the adjusted set point for a period longer than the adjustable time delay drop-out.

### Overvoltage:

Fixed at 110% of nominal voltage. Unit trips when the average of all three lines is greater than the fixed set point for a period longer than the time delay drop-out.

### Phase Unbalance:

Adjustable from 2 - 10% unbalance. Unit trips when any one of the three lines deviates from the average of all three lines by more than the adjusted set point. There is also a "Disable" setting adjustment that will turn off the Phase Unbalance Protection if nuisance tripping is a problem.

### Output Contacts:

SPDT: 10A Resistive @ 240V AC/30V DC,  
1/2HP @ 120/240V AC

### Life:

Mechanical: 10,000,000 operations  
Full Load: 100,000 operations

### Response Times:

Power Up & Restart After Fault: 1 - 300 seconds adjustable  
Drop-out Due to Fault:  
Phase Loss & Reversal 100ms fixed  
Phase Unbalance 2 seconds fixed  
Undervoltage 0.1 - 20 seconds adjustable  
Overvoltage Fixed Time Based on Inverse Time Curve

Hysteresis: 2 - 3%

Load (Burden): Less than 3VA

Temperature: -28° to 65°C (-20° to 150°F)

### Mounting:

Uses an 8 pin octal socket. Requires a 600V-rated socket when used on system voltages greater than 300V (Macromatic Product Number 70169-D--see Page 16).

### Indicator LED:

LED Status	Indicator
Green Steady	Normal / Relay ON
Green Flashing	Power Up / Restart Delay
Red Steady	Unbalance
Red Flashing	Undervoltage / Overvoltage
Amber Steady	Reversal
Amber Flashing	Loss
Green / Red Alternating	Undervoltage / Overvoltage Trip Pending
Red / Amber Alternating*	Nominal Voltage Set Error

\* Applies to 208-480V units only.

### Reset:

As standard, reset is automatic upon correction of fault. When a momentary-contact N.C. switch is wired across the Manual Reset terminals (6 & 7), the unit switches to manual reset mode and remote manual reset is available.

### Approvals:



CE Low Voltage & EMC Directives  
EN60947-1, EN60947-5-1



When used with Macromatic socket 70169-D rated 600V

File #E109466

## Dimensions

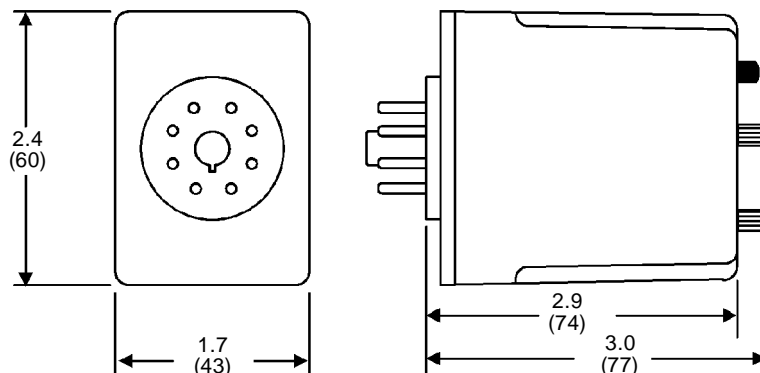

All Dimensions in Inches (Millimeters)

# PHASE MONITOR RELAYS

Phase Loss, Phase Reversal, Phase Unbalance, and Under/Over Voltage  
PMD Series Surface-Mount

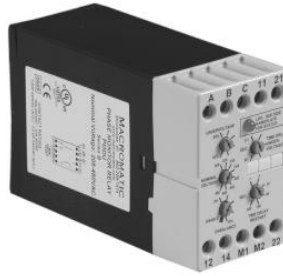

- u Universal voltage range of 208-480V on PMDU provides the flexibility to cover a variety of applications with one unit
- u Protects against phase loss, phase reversal, phase unbalance, undervoltage and overvoltage
- u Variety of user-selectable and adjustable settings for the ultimate in three-phase protection
- u Automatic or Manual Reset
- u Multi-Color LED indicates normal condition and defines fault to simplify troubleshooting
- u 45mm DIN-style surface-mount case
- u 10A SPDT & SPNC output contacts



The PMD Series Phase Monitor Relays utilize a microprocessor-based design to provide protection against phase loss, phase reversal, phase unbalance, undervoltage and overvoltage. The PMDU is a universal voltage product that works on any three-phase system voltage from 208-480V (separate 120V & 575V versions are available). These devices are designed to be compatible with most Wye or Delta systems. In Wye systems, a connection to a neutral is not required. PMD Series products protect against unbalanced voltages or single phasing regardless of any regenerative voltages.

The relay is energized when the phase sequence and all voltages are correct. Any one of five fault conditions will de-energize the relay. As standard, re-energization is automatic upon correction of the fault condition. Manual reset is available if a momentary N.C. switch is wired to the appropriate terminals. A multi-color LED indicates normal condition and also provides specific fault indication to simplify troubleshooting.

The PMD Series offers a variety of user-adjustable settings. The percent phase unbalance is adjustable from 2-10%, and also has a "Disable" setting for those applications where poor voltage conditions could cause nuisance tripping. The undervoltage drop-out can be set at 80-95% of operating voltage (overvoltage setting is fixed at 110% of nominal). The adjustable time delay drop-out on undervoltage (0.1-20 seconds) eliminates nuisance tripping caused by momentary voltage fluctuations. There is also an adjustable time delay (1-300 seconds) on both power up and restart after a fault has been cleared.

MOUNTING STYLE	OPERATING VOLTAGE 50/60 Hz	PRODUCT NUMBER u	WIRING n
Surface-Mount	120V	PMD120	<p>DIAGRAM 105</p>
	208-480V	PMDU	
	575V	PMD600	



800-238-7474

www.macromatic.com  
whats-up@macromatic.com

- u To order PMD units with a second N.O. contact instead of the N.C. (terminals 21-22), add a suffix "-A1" to the Product Number, i.e., PMDU-A1. To order PMD units with DPDT output contacts instead of one SPDT and one SPNC, **but** with no manual reset feature, add a suffix "-A2" to the Product Number, i.e., PMDU-A2.
- n See Page 16 for **Accessories**

# PHASE MONITOR RELAYS

Phase Loss, Phase Reversal, Phase Unbalance, and Under/Over Voltage  
PMD Series Surface-Mount  
Application Data & Dimensions

## Application Data

### Phase Loss:

Unit trips on loss of any Phase A, B or C.

### Phase Reversal:

Unit trips if rotation (sequence) of the three phases is anything other than A-B-C.

### Undervoltage:

Adjustable from 80-95% of nominal voltage. Unit trips when the average of all three lines is less than the adjusted set point for a period longer than the adjustable time delay drop-out.

### Overvoltage:

Fixed at 110% of nominal voltage. Unit trips when the average of all three lines is greater than the fixed set point for a period longer than the time delay drop-out.

### Phase Unbalance:

Adjustable from 2 - 10% unbalance. Unit trips when any one of the three lines deviates from the average of all three lines by more than the adjusted set point. There is also a "Disable" setting adjustment that will turn off the Phase Unbalance Protection if nuisance tripping is a problem.

### Output Contacts: SPDT & SPNC

N.O.: 10A Resistive @ 240V AC/30V DC, 1/2HP @ 240V AC

N.C.: 10A Resistive @ 240V AC/30V DC, 1/3HP @ 240 VAC

### Life:

Mechanical: 10,000,000 operations

Full Load: 100,000 operations

### Response Times:

Power Up & Restart After Fault: 1 - 300 seconds adjustable

Drop-out Due to Fault:

Phase Loss & Reversal	100ms fixed
Phase Unbalance	2 seconds fixed
Undervoltage	0.1 - 20 seconds adjustable
Overvoltage	Fixed Time Based on Inverse Time Curve

Hysteresis: 2 - 3%

Load (burden): Less than 3VA

Temperature: -28° to 65°C (-20° to 150°F)

### Mounting:

Does not require a socket. Can either be mounted directly on 35mm DIN track with no additional parts or to a back-panel with two screws.

### Indicator LED:

LED Status	Indicator
Green Steady	Normal / Relay ON
Green Flashing	Power Up / Restart Delay
Red Steady	Unbalance
Red Flashing	Undervoltage / Overvoltage
Amber Steady	Reversal
Amber Flashing	Loss
Green / Red Alternating	Undervoltage / Overvoltage Trip Pending
Red / Amber Alternating*	Nominal Voltage Set Error

\* Applies to 208-480V units only.

### Reset:

As standard, reset is automatic upon correction of fault. When a momentary-contact N.C. switch is wired across the Manual Reset terminals (5 & 6), the unit switches to manual reset mode and remote manual reset is available.

### Approvals:

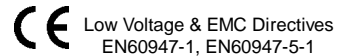



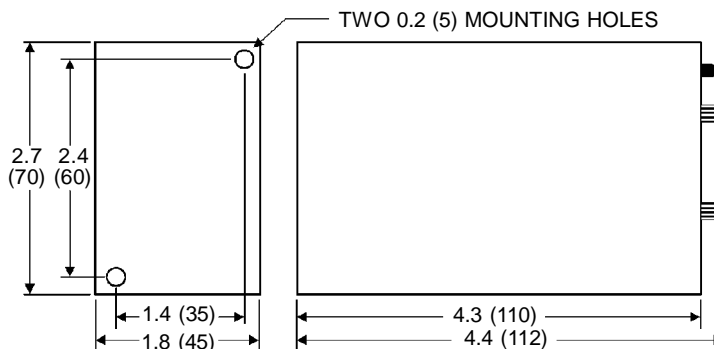



## Dimensions



All Dimensions in Inches (Millimeters)

# SOCKETS & ACCESSORIES

## Sockets

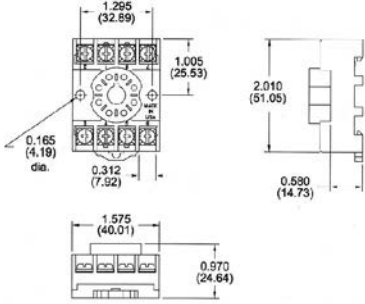
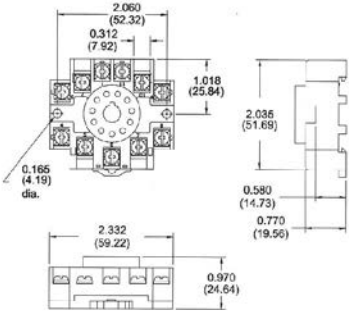
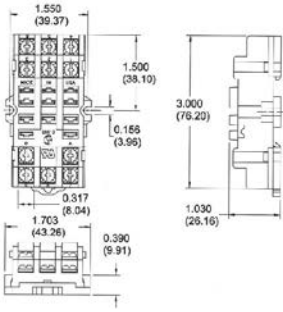
	Product Number 70169-D *	Product Number 70170-D	Product Number 70171-D
			
<b>Description</b>	8 Pin Octal	11 Pin Octal	11 Pin Spade (Blade)
<b>Ratings</b>	10A @ 600V *	10A @ 300V	10A @ 300V
<b>Mounting</b>	35MM DIN Rail / Direct Panel	35MM DIN Rail / Direct Panel	35MM DIN Rail / Direct Panel
<b>Wire/ Terminations</b>	1 or 2 #12-22 / Pressure Wire Clamps	1 or 2 #12-22 / Pressure Wire Clamps	1 or 2 #12-22 / Pressure Wire Clamps
<b>Approvals</b>			
<b>Dimensions</b>			

\* Plug-in Three-Phase Monitor Relays require a 600V-rated socket when used on system voltages greater than 300V.

## Other Accessories

Hold Down Spring  
Product Number 70166



35mm DIN Mounting Track (1 Meter Section)  
Product Number 70100

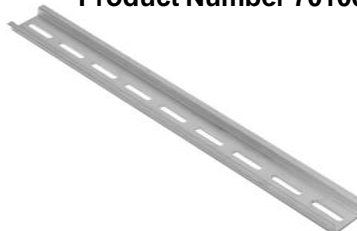



# CURRENT MONITOR RELAYS

## Product Summary



Current Monitor Relays monitor AC single phase currents for over or under current conditions. A separate 24 or 120VAC input (supply) voltage is required to power these units. Three current ranges are available: 0.1 – 1A; 0.5 – 5A; and 1 – 10A. An external current transformer may be used to extend the range of these products (see Typical Installations below). All versions are available in a compact plug-in case utilizing industry-standard 8 or 11 pin octal sockets.

The Reference Guide below provides general information on the different versions of Current Monitor Relays offered by Macromatic (see Product Selection on the following pages for further details):

Type	Series	Pick-up		Drop-out		See Page
		Setting	Time Delay	Setting	Time Delay	
<b>Standard</b> (Fixed time delay on both pick-up and drop-out current settings)	CMP	Adjustable (Across Monitored Range)	Fixed 100ms *	Fixed (-5% Pick-up)	Fixed 100ms *	18
	CMKP			Adjustable (50-95% Pick-up)	Fixed 100ms *	
<b>Overcurrent</b> (Adjustable time delay on pick-up and fixed time delay on drop-out current settings)	COP	Adjustable (Across Monitored Range)	0.1-10 sec Adjustable	Fixed (-5% Pick-up)	Fixed 100ms *	20
	COKP			Adjustable (50-95% Pick-up)	Fixed 100ms *	
<b>Undercurrent</b> (Fixed time delay on pick-up and adjustable time delay on drop-out current settings)	CUP	Fixed (+5% Drop-out)	Fixed 100ms *	Adjustable (Across Monitored Range)	0.1-10 sec Adjustable	22

\*Fixed time delay eliminates nuisance tripping due to short current surges or drops.

### Approvals

All Macromatic plug-in Current Monitor Relays are UL Component Recognized. They are also UL Listed when used with the appropriate Macromatic socket.

### Typical Installations

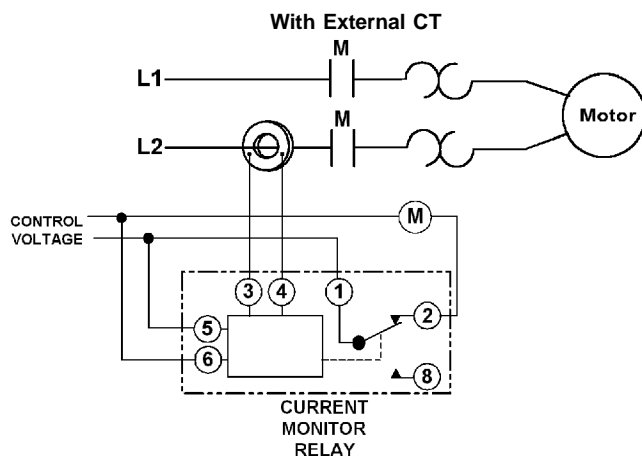
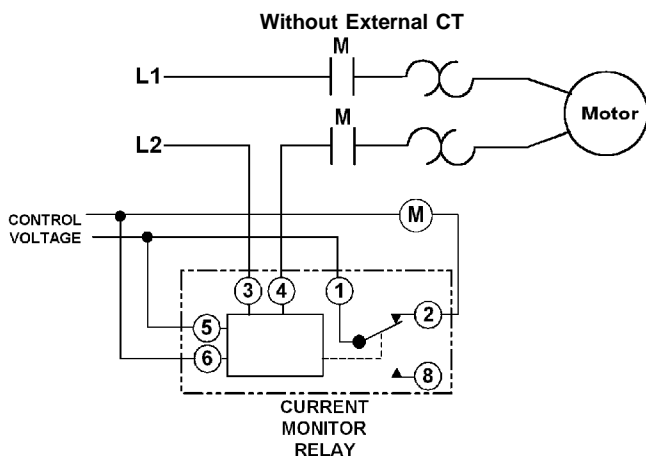

# CURRENT MONITOR RELAYS

AC Plug-In  
CM Series Standard



- Monitors AC single phase currents
- Three separate current monitoring ranges covering 0.1 - 10 amperes
- External CT can be used to extend ranges
- Adjustable Pick-up Setting with either Fixed or Adjustable Drop-out Setting
- LED indicates output relay status
- Choice of compact 8 Pin SPDT or 11 Pin DPDT plug-in case
- 10A output contacts

The CM Series is used to detect either an overcurrent or undercurrent condition. The pick-up current setting is user-adjustable within one of three ranges as shown in the Product Selection Table below. An external current transformer can be used to extend the range beyond 10 amperes.

Choose between a fixed drop-out current setting at 95% of the selected pick-up setting or an adjustable drop-out setting of 50-95% of the selected pick-up setting. The relay will energize when the monitored AC current is above the pick-up setting, and will de-energize when the monitored AC current is below the drop-out setting. The time delay on both pick-up and drop-out is fixed at 100ms (for products with adjustable time delay on pick-up, see page 20; for adjustable time delay on drop-out, see page 22).

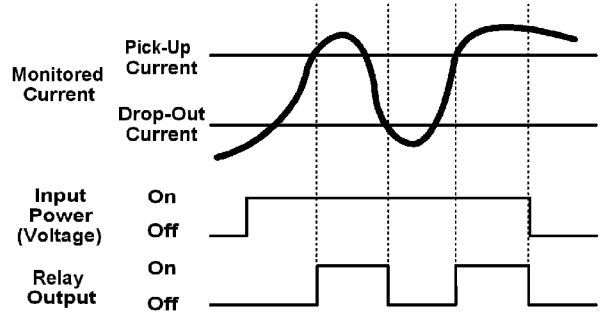

## SPDT 8 Pin Plug-in

Pick-up Setting	Drop-Out Setting	Input Voltage	Current Range Monitored	Product Number	Wiring/Socket
Adjustable	Fixed (At 95% of Pick-Up)	24V AC	0.1 - 1A 0.5 - 5A 1 - 10A	CMP01A68 CMP05A68 CMP10A68	<p><b>Diagram 21</b></p>
		120V AC	0.1 - 1A 0.5 - 5A 1 - 10A	CMP01A62 CMP05A62 CMP10A62	
Adjustable	Adjustable (From 50-95% of Pick-Up)	24V AC	0.1 - 1A 0.5 - 5A 1 - 10A	CMKP01A68 CMKP05A68 CMKP10A68	
		120V AC	0.1 - 1A 0.5 - 5A 1 - 10A	CMKP01A62 CMKP05A62 CMKP10A62	

## DPDT 11 Pin Plug-in

Pick-up Setting	Drop-Out Setting	Input Voltage	Current Range Monitored	Product Number	Wiring/Socket
Adjustable	Fixed (At 95% of Pick-Up)	24V AC	0.1 - 1A 0.5 - 5A 1 - 10A	CMP01A28 CMP05A28 CMP10A28	<p><b>Diagram 22</b></p>
		120V AC	0.1 - 1A 0.5 - 5A 1 - 10A	CMP01A22 CMP05A22 CMP10A22	
Adjustable	Adjustable (From 50-95% of Pick-Up)	24V AC	0.1 - 1A 0.5 - 5A 1 - 10A	CMKP01A28 CMKP05A28 CMKP10A28	
		120V AC	0.1 - 1A 0.5 - 5A 1 - 10A	CMKP01A22 CMKP05A22 CMKP10A22	



800-238-7474

www.macromatic.com  
whats-up@macromatic.com

Sockets & Accessories—Page 16  
Dimensions—Page 19

Application Data—Page 19

# CURRENT MONITOR RELAYS

AC PI ug-In  
CM Series Standard  
Application Data & Dimensions

## Application Data

### Input Voltage Tolerance:

AC Operation: +10/-15% of nominal at 50/60 Hz.

### Load (Burden):

Less than 5VA

### Current Settings:

Pick-up: Adjustable throughout current range monitored  
Drop-out: Fixed at 95% of pick-up setting (CMP Series); or  
Adjustable from 50-95% of pick-up setting (CMKP Series)

### Temperature:

-28° to 55° C (-20° to 131° F)

### Response Times:

Pick-up: 100ms

Drop-out: 100ms

### Output Contacts:

10A Resistive @ 240V AC/30V DC, 1/2HP @ 240V AC (N.O.),  
1/3HP @ 240V AC (N.C.)

### Life:

Mechanical: 10,000,000 operations

Full Load: 100,000 operations

**Indicator LED:** Green when Input Voltage is applied;  
Red when Relay is energized

**Reset:** Automatic. Contact Macromatic for information on a product with a latching function--the relay remains energized even after the current drops below the drop-out setting until a remote N.C. button is opened.

### Mounting:

Requires an 8 or 11 pin octal socket--see page 16.

### Approvals:



with appropriate  
Macromatic socket  
File #E109466

## Dimensions

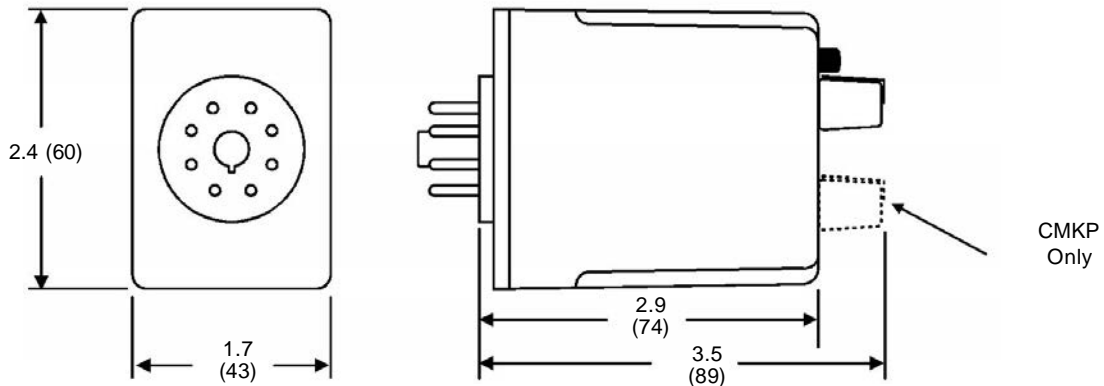

All dimensions are inches  
(millimeters)

# CURRENT MONITOR RELAYS

AC Plug-In  
CO Series Overcurrent



- Monitors AC single phase currents for overcurrent conditions
- Three separate current monitoring ranges covering 0.1 - 10 amperes
- External CT can be used to extend ranges
- Adjustable Pick-up Setting with either Fixed or Adjustable Drop-out Setting
- Adjustable time delay of 0.1-10 seconds on pick-up
- LED indicates output relay status
- Choice of compact 8 Pin SPDT or 11 Pin DPDT plug-in case

- 10A output contacts



(with appropriate socket)

The CO Series is used to detect an overcurrent condition. The pick-up current setting is user-adjustable within one of three ranges as shown in the Product Selection Table below. An external current transformer can be used to extend the range beyond 10 amperes.

Choose between a fixed drop-out current setting at 95% of the selected pick-up setting or an adjustable drop-out setting of 50-95% of the selected pick-up setting. The relay will energize when the monitored AC current is above the pick-up setting for a period longer than the adjustable time delay of 0.1-10 seconds. This delay prevents nuisance tripping caused by inrush currents. It will de-energize when the monitored AC current is below the drop-out setting.

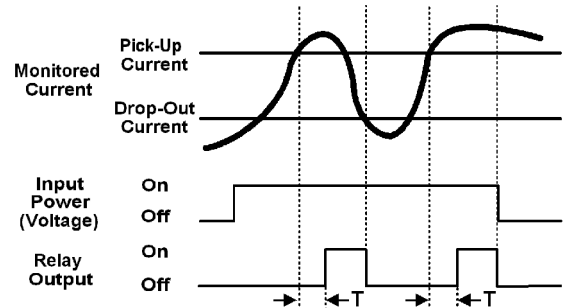

## 8 Pin SPDT Plug-in

Pick-up Setting	Drop-Out Setting	Input Voltage	Current Range Monitored	Product Number	Wiring/Socket
Adjustable	Fixed (At 95% of Pick-Up)	24V AC	0.1 - 1A 0.5 - 5A 1 - 10A	COP01A68 COP05A68 COP10A68	<p>Diagram 21</p>
		120V AC	0.1 - 1A 0.5 - 5A 1 - 10A	COP01A62 COP05A62 COP10A62	
Adjustable	Adjustable (From 50-95% of Pick-Up)	24V AC	0.1 - 1A 0.5 - 5A 1 - 10A	COKP01A68 COKP05A68 COKP10A68	
		120V AC	0.1 - 1A 0.5 - 5A 1 - 10A	COKP01A62 COKP05A62 COKP10A62	

## 11 Pin DPDT Plug-in

Pick-up Setting	Drop-Out Setting	Input Voltage	Current Range Monitored	Product Number	Wiring/Socket
Adjustable	Fixed (At 95% of Pick-Up)	24V AC	0.1 - 1A 0.5 - 5A 1 - 10A	COP01A28 COP05A28 COP10A28	<p>Diagram 22</p>
		120VAC	0.1 - 1A 0.5 - 5A 1 - 10A	COP01A22 COP05A22 COP10A22	
Adjustable	Adjustable (From 50-95% of Pick-Up)	24V AC	0.1 - 1A 0.5 - 5A 1 - 10A	COKP01A28 COKP05A28 COKP10A28	
		120V AC	0.1 - 1A 0.5 - 5A 1 - 10A	COKP01A22 COKP05A22 COKP10A22	



800-238-7474

www.macromatic.com  
whats-up@macromatic.com

Sockets & Accessories–Page 16  
Dimensions–Page 21

Application Data–Page 21

# CURRENT MONITOR RELAYS

AC Plug-in  
CO Series Overcurrent  
Application Data & Dimensions

## Application Data

### Input Voltage Tolerance:

AC Operation: +10/-15% of nominal at 50/60 Hz.

### Load (Burden):

Less than 5VA

### Current Settings:

Pick-up: Adjustable throughout current range monitored  
Drop-out: Fixed at 95% of pick-up setting (COP Series); or  
Adjustable from 50-95% of pick-up setting (COKP Series)

### Temperature:

-28° to 55° C (-20° to 131° F)

### Response Times:

Pick-up: Adjustable 0.1-10 seconds

Drop-out: Fixed 100ms

### Output Contacts:

10A Resistive @ 240V AC/30V DC, 1/2HP @ 240V AC (N.O.),  
1/3HP @ 240V AC (N.C.)

### Life:

Mechanical: 10,000,000 operations

Full Load: 100,000 operations

**Indicator LED:** Green when Input Voltage is applied;  
Red Flashing when in time delay; and Red Steady when  
Relay is energized.

**Reset:** Automatic. Contact Macromatic for information  
on a product with a latching function--the relay remains  
energized even after the current drops below the drop-  
out setting until a remote N.C. button is opened.

### Mounting:

Requires an 8 or 11 pin octal socket--see page 16.

### Approvals:



File #E109466



with appropriate  
Macromatic socket  
File #E109466

## Dimensions

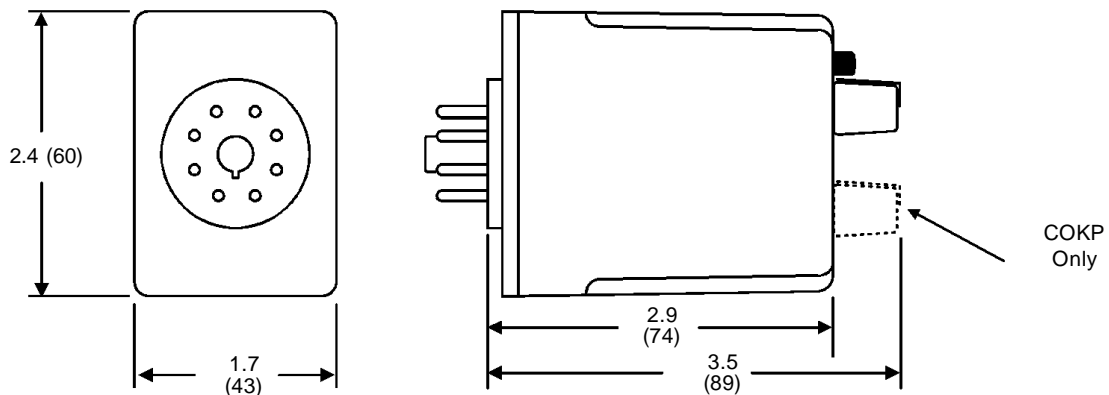

All dimensions are inches  
(millimeters)

# CURRENT MONITOR RELAYS

AC Plug-in  
CU Series Under current



- Monitors AC single phase currents for undercurrent conditions
- Three separate current monitoring ranges covering 0.1 - 10 amperes
- External CT can be used to extend ranges
- Adjustable Drop-out Setting with Fixed Pick-up Setting
- Adjustable time delay of 0.1-10 seconds on drop-out
- LED indicates output relay status
- Choice of compact 8 Pin SPDT or 11 Pin DPDT plug-in case

- 10A output contacts



The CU Series is used to detect an undercurrent condition. The drop-out current setting is user-adjustable within one of three ranges as shown in the Product Selection Table below. An external current transformer can be used to extend the range beyond 10 amperes.

The pick-up current setting is fixed at +5% of the selected drop-out setting. The relay will energize when the monitored AC current is above the pick-up setting. It will de-energize when the monitored AC current is below the drop-out setting for a period longer than the adjustable time delay of 0.1-10 seconds. This delay prevents nuisance tripping caused by momentary line dips. The relay will energize when the current rises 5% above the drop-out setting.

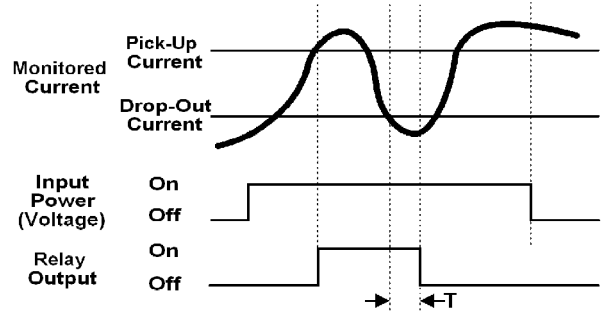

## 8 Pin SPDT Plug-in

Pick-up Setting	Drop-Out Setting	Input Voltage	Current Range Monitored	Product Number	Wiring/Socket
Fixed (At +5% of Drop-Out)	Adjustable	24V AC	0.1 - 1A 0.5 - 5A 1 - 10A	CUP01A68 CUP05A68 CUP10A68	<p>Diagram 21</p>
		120V AC	0.1 - 1A 0.5 - 5A 1 - 10A	CUP01A62 CUP05A62 CUP10A62	

## 11 Pin DPDT Plug-in

Pick-up Setting	Drop-Out Setting	Input Voltage	Current Range Monitored	Product Number	Wiring/Socket
Fixed (At +5% of Drop-Out)	Adjustable	24V AC	0.1 - 1A 0.5 - 5A 1 - 10A	CUP01A28 CUP05A28 CUP10A28	<p>Diagram 22</p>
		120V AC	0.1 - 1A 0.5 - 5A 1 - 10A	CUP01A22 CUP05A22 CUP10A22	



800-238-7474

www.macromatic.com  
whats-up@macromatic.com

Sockets & Accessories—Page 16  
Dimensions—Page 23

Application Data—Page 23

# CURRENT MONITOR RELAYS

AC PI ug-in  
CU Series Undercurrent  
Application Data & Dimensions

## Application Data

### Input Voltage Tolerance:

AC Operation: +10/-15% of nominal at 50/60 Hz.

### Load (Burden):

Less than 5VA

### Current Settings:

Pick-up: Fixed at 5% above adjustable drop-out setting  
Drop-out: Adjustable throughout current range monitored

### Temperature:

-28° to 55° C (-20° to 131° F)

### Response Times:

Pick-up: Fixed 100ms  
Drop-out: Adjustable 0.1-10 seconds

### Output Contacts:

10A Resistive @ 240V AC/30V DC, 1/2HP @ 240V AC (N.O.), 1/3HP @ 240V AC (N.C.)

### Life:

Mechanical: 10,000,000 operations  
Full Load: 100,000 operations

**Indicator LED:** Green when Input Voltage is applied;  
Red Flashing when in time delay; and Red Steady when  
Relay is energized.

**Reset:** Automatic

### Mounting:

Requires an 8 or 11 pin octal socket--see page 16.

### Approvals:



File #E109466



with appropriate  
Macromatic socket  
File #E109466

## Dimensions

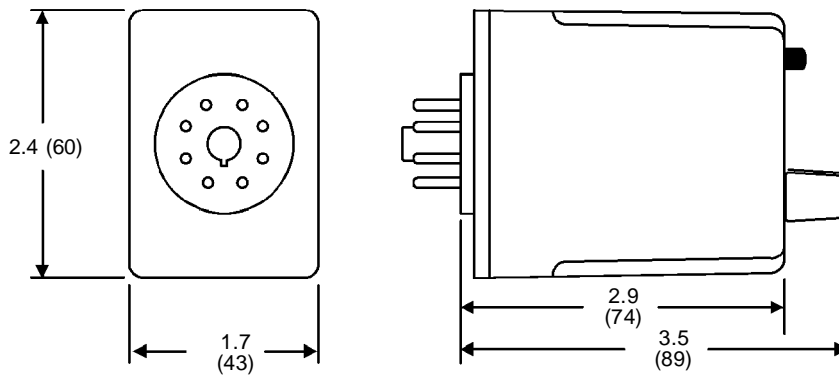

All dimensions are inches  
(millimeters)

# VOLTAGE MONITOR RELAYS

## Product Summary



Voltage Monitor Relays monitor either AC single phase (50-60Hz) or DC voltages to protect equipment against voltage fault conditions. No separate supply (input) voltage is required on any Macromatic Voltage Monitor Relays. All versions are available in a compact plug-in case utilizing an 8 pin octal socket.

Macromatic offers two styles of Voltage Monitor Relays:

- ⊍ Over/Under Voltage Relays--provides protection to equipment where either an over or under voltage condition is potentially damaging. When used as an under voltage relay, they provide protection to equipment that is required to operate above a minimum voltage. When used as over voltage relays, they protect equipment against excessive voltage conditions. Over/Under Voltage Relays are designed to operate when the operating voltage reaches a preset value and drop-out when the operating voltage drops to a level below the preset value.
- ⊍ Voltage Band Relays--provides protection to equipment that is required to operate within an upper & lower voltage limit. As long as the operating voltage remains within an OVER & UNDER voltage range, the internal relay stays energized. If the operating voltage falls outside this range, the relay will drop-out.

These products are summarized below:

### Over/Undervoltage Relays

Series	Pick-up Voltage	Drop-out Voltage	Time Delay Drop-Out	Function Chart	Page
VMP	Adjustable 85-115% Nominal	Fixed at 95% of Pick-Up	Fixed 500ms *		25
VMKP	Adjustable 85-115% Nominal	Adjustable 75-95% of Pick-up	Fixed 500ms *		25
VAP	Adjustable 85-115% Nominal	Fixed at 95% of Pick-Up	Adjustable 0.5-10 seconds		26
VAKP	Adjustable 85-115% Nominal	Adjustable 75-95% of Pick-up	Adjustable 0.5-10 seconds		26

### Voltage Band Relays

Series	Over Voltage	Under Voltage	Time Delay Drop-Out	Function Chart	Page
VWP	Adjustable 100-125% of Nominal	Adjustable 75-100% of Nominal	Fixed 500ms *		28
VWKP	Adjustable 100-125% of Nominal	Adjustable 75-100% of Nominal	Adjustable 0.5-10 seconds		28

\*Fixed time delay eliminates nuisance tripping due to short voltage surges or drops.

### Approvals

All Macromatic plug-in Voltage Monitor Relays are UL Component Recognized. They are also UL Listed when used with the appropriate Macromatic socket.



# VOLTAGE MONITOR RELAYS

VM Series Over/Under voltage  
Fixed Time Delay on Drop-Out



Over/Under Voltage Relays provide protection to equipment where either an over or under voltage condition is potentially damaging. They are designed to operate when the operating voltage reaches a preset value and drop-out when the operating voltage drops to a level below the preset value.

The pick-up voltage setting is user-adjustable from 85-115% of the nominal voltage rating. As standard, the VMP Series has a drop-out voltage setting fixed at 95% of the pick-up voltage setting. An adjustable drop-out setting of 75-95% of the pick-up setting is available on the VMKP Series. The relay energizes when the

monitored voltage is above the pick-up setting. The relay de-energizes when the monitored voltage is below the drop-out setting for a period longer than the drop-out time delay (T), which is a fixed 500ms for VM Series products. An adjustable time delay on drop-out of 0.5-10 seconds is available (see Page 26).

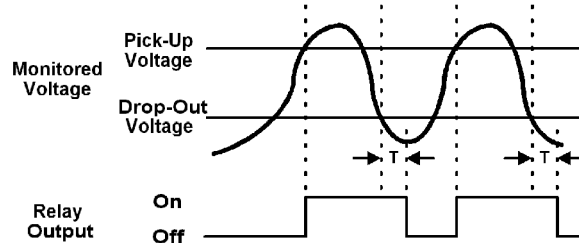

- u Monitors AC single phase and DC voltages
- u Wide range of user-adjustable pick-up and drop-out settings
- u Fixed time delay on drop-out of 500ms
- u LED indicates output relay status
- u Compact plug-in case utilizing industry standard 8 pin octal socket
- u 10A DPDT output contacts



(with appropriate socket)

### Adjustable Pick-Up, Fixed Drop-Out Settings \* Time Delay on Drop-out Fixed at 500ms

NOMINAL VOLTAGE <sup>l</sup>	PICK-UP VOLTAGE RANGE	DROP-OUT VOLTAGE RANGE*	PRODUCT NUMBER	WIRING/SOCKET
24V AC 120V AC	21-27V AC 102-138V AC	20-26V AC 97-131V AC	VMP024A VMP120A	8 Pin Octal <b>70169-D</b> DIAGRAM 20
12V DC 24V DC 48V DC 110V DC	10-14V DC 21-27V DC 41-55V DC 94-126V DC	9-13V DC 20-26V DC 39-52V DC 89-121V DC	VMP012D VMP024D VMP048D VMP110D	

\* Drop-out Voltage is fixed at 95% of the adjusted Pick-up Setting.

### Adjustable Pick-Up & Drop-Out Settings \*\* Time Delay on Drop-out Fixed at 500ms

NOMINAL VOLTAGE <sup>l</sup>	PICK-UP VOLTAGE RANGE	DROP-OUT VOLTAGE RANGE	PRODUCT NUMBER <sup>n</sup>	WIRING/SOCKET
24V AC 120V AC	21-27V AC 102-138V AC	16-26V AC 77-131V AC	VMKP024A VMKP120A	8 Pin Octal <b>70169-D</b> DIAGRAM 20
12V DC 24V DC 48V DC 110V DC	10-14V DC 21-27V DC 41-55V DC 94-126V DC	8-13V DC 16-26V DC 32-52V DC 71-121V DC	VMKP012D VMKP024D VMKP048D VMKP110D	

\*\* Drop-out Voltage is adjustable from 75-95% of the adjusted Pick-up Setting.

<sup>l</sup> Contact Macromatic for information on units above 120V.

<sup>n</sup> These products replace those products previously sold with a suffix "-G"-contact Macromatic for more information.



**800-238-7474**

[www.macromatic.com](http://www.macromatic.com)  
[whats-up@macromatic.com](mailto:whats-up@macromatic.com)

# VOLTAGE MONITOR RELAYS

VA Series Over/Under voltage  
Adjustable Time Delay on Drop-Out

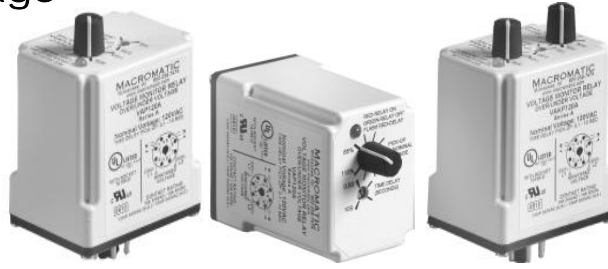

- u Monitors AC single phase and DC voltages
- u Wide range of user-adjustable pick-up and drop-out settings
- u Adjustable time delay on drop-out of 0.5 - 10 seconds
- u LED indicates output relay status
- u Compact plug-in case utilizing industry standard 8 pin octal socket
- u 10A DPDT output contacts



(with appropriate socket)

Over/Under Voltage Relays provide protection to equipment where an over or under voltage condition is potentially damaging. They are designed to operate when the operating voltage reaches a preset value and drop-out when the operating voltage drops to a level below the preset value.

The pick-up voltage setting is user-adjustable from 85-115% of the nominal voltage rating. As standard, the VAP Series has a drop-out voltage setting fixed at 95% of the pick-up voltage setting. An adjustable drop-out setting of 75-95% of the pick-up setting is available on the VAKP Series. The relay energizes when the monitored voltage is above the pick-up setting. The relay de-energizes when the monitored voltage is below the drop-out setting for a period longer than the drop-out time delay (T), which is adjustable from 0.5-10 seconds for VA Series products. A time delay on drop-out fixed at 500ms is available (see Page 25).

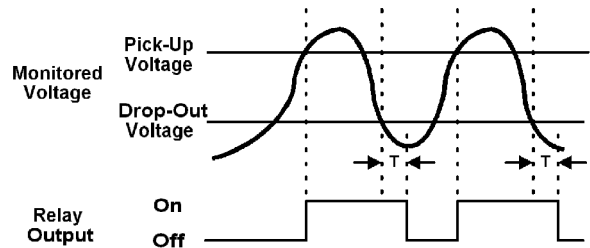

### Adjustable Pick-Up, Fixed Drop-Out Settings \* Adjustable Time Delay on Drop-out from 0.5 - 10 Seconds

NOMINAL VOLTAGE <sup>1</sup>	PICK-UP VOLTAGE RANGE	DROP-OUT VOLTAGE RANGE*	PRODUCT NUMBER	WIRING/SOCKET
24V AC 120V AC	21-27V AC 102-138V AC	20-26V AC 97-131V AC	VAP024A VAP120A	8 Pin Octal <b>70169-D</b>  <b>DIAGRAM 20</b>
12V DC 24V DC 48V DC 110V DC	10-14V DC 21-27V DC 41-55V DC 94-126V DC	9-13V DC 20-26V DC 39-53V DC 89-121V DC	VAP012D VAP024D VAP048D VAP110D	

\* Drop-out Voltage is fixed at 95% of the adjusted Pick-up Setting.

### Adjustable Pick-Up & Drop-Out Settings \*\* Adjustable Time Delay on Drop-out from 0.5 - 10 Seconds

NOMINAL VOLTAGE <sup>1</sup>	PICK-UP VOLTAGE RANGE	DROP-OUT VOLTAGE RANGE	PRODUCT NUMBER	WIRING/SOCKET
24V AC 120V AC	21-27V AC 102-138V AC	16-26V AC 77-131V AC	VAKP024A VAKP120A	8 Pin Octal <b>70169-D</b>  <b>DIAGRAM 20</b>
12V DC 24V DC 48V DC 110V DC	10-14V DC 21-27V DC 41-55V DC 94-126V DC	8-13V DC 16-26V DC 32-52V DC 71-121V DC	VAKP012D VAKP024D VAKP048D VAKP110D	

\*\* Drop-out Voltage is adjustable from 75-95% of the adjusted Pick-up Setting.

<sup>1</sup> Contact Macromatic for information on units above 120V.



800-238-7474

www.macromatic.com  
whats-up@macromatic.com

# VOLTAGE MONITOR RELAYS

## VM & VA Series Over/Undervoltage Application Data & Dimensions

### Operating Modes

These relays can be used as either overvoltage or undervoltage relays, depending on the output contact used:

#### **Overvoltage Relay**

Provides protection to equipment that cannot handle excess voltages. Uses a normally closed contact (N.C.). As long as the monitored voltage remains below the maximum voltage the equipment can withstand (Pick-Up Setting), the relay remains de-energized and the N.C. contact remains closed, keeping the load energized. If the operating voltage increases beyond the maximum rating of the equipment, the relay energizes and the N.C. contact opens, turning off the load. When the voltage falls below the Drop-Out Setting (hysteresis), the relay de-energizes and the N.C. contact re-closes, turning on the load.

#### **Undervoltage Relay**

Provides protection to equipment that is required to operate above a certain minimum voltage. Uses a normally open contact (N.O.). As long as the monitored voltage is above the minimum value required (Pick-Up Setting), the relay will energize and the N.O. contact closes, turning on the load. If the voltage drops below the Drop-out Setting (the minimum voltage required minus the hysteresis), the relay will de-energize and the N.O. contact will re-open, turning off the load.

### Application Data

#### **Voltage Tolerance:**

+25%/-50% of nominal voltage; AC voltages are 50-60Hz;  
No separate supply (input) voltage is required.

**Load (Burden):** Less than 3VA

#### **Voltage Settings:**

Pick-up: Adjustable from 85-115% of nominal voltage  
Drop-out: Fixed at 95% of the pick-up setting (VMP & VAP Series)  
Adjustable from 75-95% of pick-up setting (VMKP & VAKP Series)

#### **Temperature:**

-28° to 55° C (-20° to 131° F)

#### **Output Contacts:**

10A Resistive @ 240V AC/30V DC, 1/2HP @ 240V AC (N.O.),  
1/3HP @ 240V AC (N.C.)

#### **Life:**

Mechanical: 10,000,000 operations  
Full Load: 100,000 operations

#### **Response Times:**

Operate: 500ms

Release: Fixed 500 ms (VMP & VMKP Series)  
Adjustable 0.5 - 10 Seconds (VAP & VAKP Series)

**Indicator LED:** Red Steady when Relay is energized; Green when Relay is Off.

#### **Transient Protection:**

10,000 volts for 20 microseconds

**Reset:** Automatic. Contact Macromatic for information on how to order a unit with Manual Reset.

#### **Approvals:**



File #E109466



with appropriate  
Macromatic socket  
File #E109466

### Dimensions

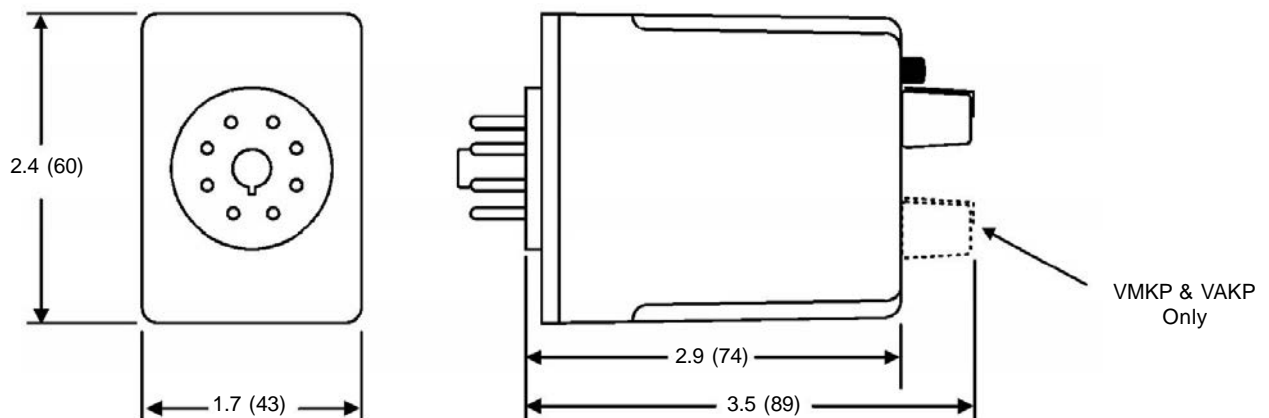

All Dimensions in  
Inches (Millimeters)

# VOLTAGE MONITOR RELAYS

## VW Series Voltage Band



- u Monitors AC single phase and DC voltages
- u Provides voltage band (window) protection
- u Wide range of user-adjustable Over Voltage and Under Voltage settings
- u Fixed or adjustable time delay on drop-out
- u LED indicates output relay status
- u Compact plug-in case utilizing industry standard 8 pin octal socket
- u 10A DPDT output contacts



(with appropriate socket)

Voltage Band Relays provide protection to equipment that is required to operate within an upper & lower voltage limit. As long as the operating voltage remains within an OVER & UNDER voltage range, the internal relay stays energized. If the operating voltage falls outside this range, the relay will drop-out.

When nominal operating voltage with a value between the UPPER & LOWER setting is applied, the internal relay will energize (Pick-up). If the operating voltage falls outside the preset OVER trip point (adjustable 100-125% of nominal) or UNDER trip point (adjustable 75-100% of nominal) for a period longer than the drop-out time

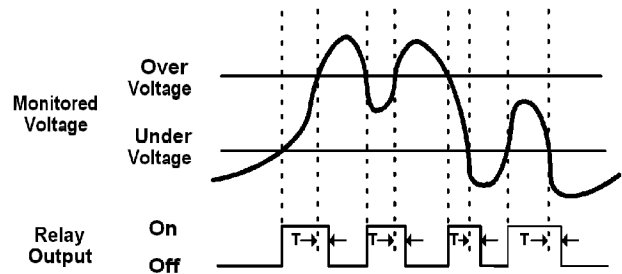

delay (T), the relay will de-energize (Drop-out). When the voltage returns to normal (within the preset OVER & UNDER trip points), the unit automatically resets and the relay energizes. Choose between a unit with fixed drop-out time of 500ms or one with an adjustable 0.5-10 second drop-out time.

### Fixed Drop-Out Time Delay (500ms)

NOMINAL VOLTAGE <sup>1</sup>	OVER VOLTAGE RANGE	UNDER VOLTAGE RANGE	PRODUCT NUMBER	WIRING/SOCKET
24V AC 120V AC	24-30V AC 120-150V AC	18-24V AC 90-120V AC	VWP024A VWP120A	8 Pin Octal <b>70169-D</b>  <b>DIAGRAM 20</b>
12V DC 24V DC 48V DC 110V DC	12-15V DC 24-30V DC 48-60V DC 110-137V DC	9-12V DC 18-24V DC 36-48V DC 83-110V DC	VWP012D VWP024D VWP048D VWP110D	

### Adjustable Drop-Out Time Delay 0.5 - 10 Seconds

NOMINAL VOLTAGE <sup>1</sup>	OVER VOLTAGE RANGE	UNDER VOLTAGE RANGE	PRODUCT NUMBER	WIRING/SOCKET
24V AC 120V AC	24-30V AC 120-150V AC	18-24V AC 90-120V AC	VWKP024A VWKP120A	8 Pin Octal <b>70169-D</b>  <b>DIAGRAM 20</b>
12V DC 24V DC 48V DC 110V DC	12-15V DC 24-30V DC 48-60V DC 110-137V DC	9-12V DC 18-24V DC 36-48V DC 83-110V DC	VWKP012D VWKP024D VWKP048D VWKP110D	

<sup>1</sup> Contact Macromatic for information on units above 120V.



**800-238-7474**

[www.macromatic.com](http://www.macromatic.com)  
[whats-up@macromatic.com](mailto:whats-up@macromatic.com)

# VOLTAGE MONITOR RELAYS

VW Series Voltage Band  
Application Data & Dimensions

## Application Data

### Voltage Tolerance:

+25%/-50% of nominal voltage; AC voltages are 50-60Hz;  
No separate supply (input) voltage is required.

**Load (Burden):** Less than 3VA

### Voltage Settings:

Over Voltage: 100-125% of Nominal Voltage  
Under Voltage: 75-100% of Nominal Voltage

### Temperature:

-28° to 55° C (-20° to 131° F)

**Indicator LED:** Red Steady when Relay is energized; Green when Relay is Off.

**Reset:** Automatic. Contact Macromatic for information on how to order a unit with Manual Reset.

### Response Times:

Operate: 500ms  
Release: Fixed 500 ms (VWP Series)  
Adjustable 0.5 -10 Seconds (VWKP Series)

### Output Contacts:

10A Resistive @ 240V AC/30V DC, 1/2HP @ 240V AC (N.O.),  
1/3HP @ 240V AC (N.C.)

### Life:

Mechanical: 10,000,000 operations  
Full Load: 100,000 operations

### Transient Protection:

10,000 volts for 20 microseconds

### Approvals:



File #E109466



with appropriate  
Macromatic socket  
File #E109466

## Dimensions

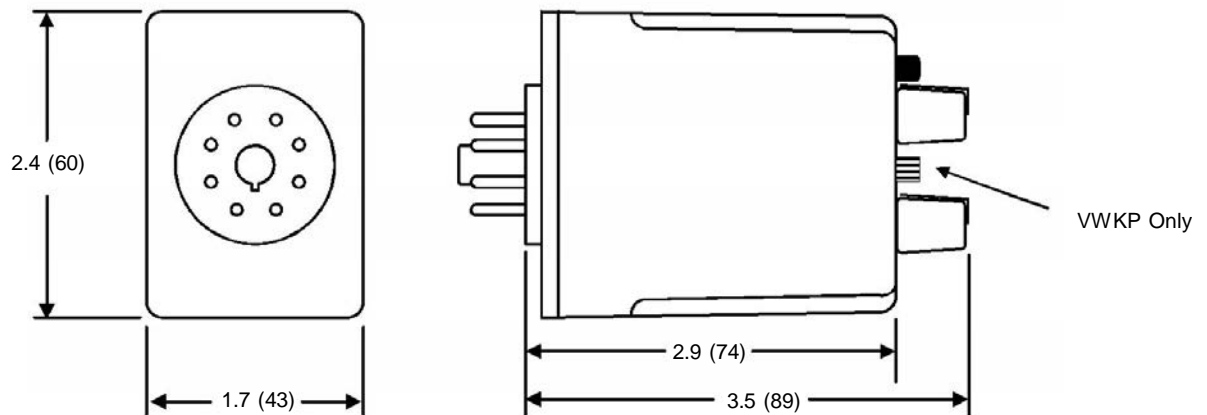







All Dimensions in  
Inches (Millimeters)

# TIME DELAY RELAYS

## Product Summary

Macromatic offers a wide variety of time delay relays and accessories. Each one has different features and operating characteristics, allowing you to choose the exact product to meet your needs. Our time delay relays are available in either programmable or non-programmable versions. We offer both single or multiple function time delay relays. Choose between SPDT or DPDT relay outputs. Time delay relays are available as plug-in units for use with industry standard 8 & 11 pin octal or 11 pin blade sockets, or as an open board version for OEM applications. Choose between analog or digital-set time delay relays. Refer to the Selection Table on these two pages for more information.







	<b>Standard Non-Programmable Single-Range Plug-in</b>	<b>Time Ranger Multi-Range Programmable Plug-in</b>	<b>Compact Non-Programmable Single-Range Plug-in</b>
<b>Series</b>	TR-5	TR-6	SS-6 & SS-8
			
<b>Timing Functions Available</b>	<ul style="list-style-type: none"> <li>* On Delay</li> <li>* Interval On</li> <li>* Flasher</li> <li>* Off Delay</li> <li>* Single Shot</li> <li>* Watchdog</li> <li>* Repeat Cycle</li> <li>* Delayed Interval</li> </ul>	<ul style="list-style-type: none"> <li>* On Delay</li> <li>* Interval On</li> <li>* Flasher</li> <li>* Off Delay</li> <li>* Single Shot</li> <li>* Watchdog</li> <li>* Repeat Cycle</li> <li>* Delayed Interval</li> </ul>	<ul style="list-style-type: none"> <li>* On Delay</li> <li>* Interval On</li> <li>* Off Delay</li> <li>* Single Shot</li> </ul>
<b>Timing Ranges Available</b>	20 separate timing ranges from 0.02 Seconds to 24 Hours	16 field-programmable timing ranges covering up to 2 Hours (24 Hours on Dual Knob units) in one unit	6 separate timing ranges from 0.02 to 300 Seconds
<b>Output Contacts</b>	DPDT or SPDT 10A @ 240V AC 10A @ 28V DC 1/2HP @ 240V AC 1/3HP @ 120V AC B300/R300	DPDT 10A @ 240V AC 10A @ 28V DC 1/2HP @ 240V AC 1/3HP @ 120V AC B300/R300	SPDT 5A @ 120V AC 5A @ 28V DC 1/6HP @ 120V AC
<b>Input Voltages</b>	12V AC/DC, 24V AC/DC, 120V AC/DC & 240V AC	12V AC/DC, 24V AC/DC, 120V AC/DC & 240V AC	12V AC/DC, 24V AC/DC & 120V AC
<b>Approvals</b>	 with appropriate socket	 with appropriate socket	 with appropriate socket
<b>See Page</b>	34-39	40-43	44

# TIME DELAY RELAYS

## Product Summary

See pages 32 & 33 for a detailed description of all timing functions available. If you have any questions regarding the selection or application of time delay relays, either visit our on-line Technical Resource Center ([www.macromatic.com](http://www.macromatic.com)) or call us at 800-238-7474.

Need modifications such as fixed time delays, remote adjustments or special pin configurations? We can do most of these modifications within our normal lead-times. See pages 50 & 51 for more information.

	<b>Spade Base Non-Programmable Single Range Plug-in</b>	<b>Time Ranger Digital-Set Multi-Range Programmable Plug-in</b>	<b>Time Ranger III Digital-Set Multi-Function Multi-Range Programmable</b>
<b>Series</b>	SS-4	TD-7	981
			
<b>Timing Functions Available</b>	<ul style="list-style-type: none"> <li>* On Delay</li> <li>* Off Delay</li> </ul>	<ul style="list-style-type: none"> <li>* On Delay</li> <li>* Interval On</li> <li>* Flasher</li> <li>* Off Delay</li> <li>* Single Shot</li> </ul> <p>Available in both single function &amp; multifunction</p>	<p><u>All in One Unit:</u></p> <ul style="list-style-type: none"> <li>* On Delay</li> <li>* Interval On</li> <li>* Flasher</li> <li>* Off Delay (2 versions)</li> <li>* Interval On/Off Delay</li> <li>* On Delay/Off Delay</li> <li>* Delayed Interval</li> </ul>
<b>Timing Ranges Available</b>	3 separate timing ranges from 0.1 to 300 Seconds	0.05 Seconds to 999 Hours programmable timing range	0.1 Seconds to 9,999 Hours programmable timing range
<b>Output Contacts</b>	DPDT 12A @ 240V AC 12A @ 30V DC 1/2HP @ 240V AC B300/R300	DPDT 10A @ 240V AC 10A @ 28V DC 1/2HP @ 240V AC 1/3HP @ 120V AC B300/R300	SPDT 3A @ 240V AC 5A @ 30V DC 1/2HP @ 240V AC
<b>Input Voltages</b>	12V AC/DC, 24V AC/DC & 120V AC	12V AC/DC, 24V AC/DC, 120V AC/DC & 240V AC	24-240V AC & 12-240V DC in one unit
<b>Approvals</b>	 with appropriate socket	 with appropriate socket	
<b>See Page</b>	45	46-47	48-49

# TIME DELAY RELAYS

## Definition of Timing Functions

Understanding the differences between all the functions available in time delay relays can sometimes be a daunting task. To begin with, time delay relays are simply control relays with a time delay built in. Their purpose is to control an event based on time.

Typically, time delay relays are initiated or triggered by one of two methods:

- u application of input voltage (On Delay, Interval On, Flasher, Repeat Cycle & Delayed Interval)
- u opening or closing of a trigger signal (Off Delay, Single Shot, Watchdog & Triggered Delayed Interval)

These trigger signals can be one of two designs: a control switch (dry contact), i.e., limit switch, push button, float switch, etc., or by voltage (commonly known as a power trigger).

To help understand, some definitions are important:

- u **Input Voltage**-control voltage applied to the input terminals. Depending on the function, input voltage will either initiate the unit or make it ready to initiate when a trigger signal is applied.
- u **Trigger Signal**-on certain timing functions, a trigger signal is used to initiate the unit after input voltage has been applied. As noted above, this trigger signal can either be a control switch (dry contact switch) or a power trigger (voltage).
- u **Output (Load)**-every time delay relay has an internal relay (usually mechanical) with contacts that open & close to control the load. They are represented by the dotted lines in the wiring diagrams. Note that the user must provide the voltage to power the load being switched by the output contacts of the time delay relay.

Below and on the following page are both written and visual descriptions on how the common timing functions operate. A Timing Chart shows the relationship between Input Voltage, Trigger Signal (if present) and Output Contacts. If you cannot find a product to fit your requirements or have any questions, Macromatic's Application Engineers offer technical information along with product selection and application assistance. Just call us at 800-238-7474 or e-mail us at tech-help@macromatic.com.

Function	Operation	Timing Chart
<b>ON DELAY</b> Delay on Operate Delay on Make	Upon application of input voltage, the preset time begins. At the end of the preset time, the relay is energized. Input voltage must be removed and reapplied to reset the time delay & de-energize the relay.	
<b>INTERVAL ON</b> Interval	Upon application of input voltage, the relay is energized and the preset time begins. At the end of the preset time, the relay is de-energized. Input voltage must be removed and reapplied to reset the time delay.	
<b>OFF DELAY</b> Delay on Release Delay on De-Energization Delay on Drop-Out	Upon application of input voltage, the time delay relay is ready to accept trigger signals. Upon application of the trigger signal, the relay is energized. Upon release of the trigger signal, the preset time begins. At the end of the preset time, the relay is de-energized. Any application of the trigger signal during the preset time will keep the relay energized & reset the time delay.	
<b>SINGLE SHOT</b> One Shot Momentary Interval	Upon application of input voltage, the time delay relay is ready to accept trigger signals. Upon application of the trigger signal, the relay is energized and the preset time begins. During the preset time, the trigger signal is ignored. The time delay relay is reset by applying the trigger signal when the relay is not energized.	



# TIME DELAY RELAYS

## Definition of Timing Functions

Function	Operation	Timing Chart
<b>WATCHDOG</b> Retriggerable Single Shot	Upon application of input voltage, the time delay relay is ready to accept trigger signals. Upon application of the trigger signal, the relay is energized and the preset time begins. At the end of the preset time, the relay is de-energized unless the trigger signal is closed and opened prior to time out (before preset time elapses). Continuous cycling of the trigger signal at a rate faster than the preset time will cause the relay to remain energized.	
<b>FLASHER</b>	Upon application of input voltage, the preset time (T1) begins. At the end of the preset time, the relay is energized and remains in that condition for the preset time (T1). At the end of this time, the relay is de-energized and the sequence repeats until input voltage is removed.	
<b>REPEAT CYCLE</b> Off/On Delay	Upon application of input voltage, a preset delay begins (OFF). At the end of the preset delay, the relay is energized and remains in that condition for a second, independently adjustable preset time (ON). At the end of this time, the relay is de-energized and the sequence repeats until input voltage is removed.	
<b>REPEAT CYCLE</b> On/Off Delay	Upon application of input voltage, the relay is energized and a preset delay begins (ON). At the end of the preset delay, the relay is de-energized and remains in that condition for a second, independently adjustable preset time (OFF). At the end of this time, the relay is energized and the sequence repeats until input voltage is removed.	
<b>DELAYED INTERVAL</b> Single Cycle	Upon application of input voltage, a preset delay begins (OFF). At the end of the preset delay, the relay is energized and remains in that condition for a second, independently adjustable preset time (ON). At the end of the second preset time, the relay is de-energized. Input voltage must be removed and reapplied to reset the time delay relay.	
<b>DELAYED INTERVAL (TRIGGERED)</b> Single Cycle	Upon application of input voltage, the time delay relay is ready to accept trigger signals. Upon application of the trigger signal, a preset delay begins (OFF). At the end of the preset delay, the relay is energized and remains in that condition for a second, independently adjustable preset time (ON). At the end of the second preset time, the relay is de-energized. During both the OFF time & the ON time, the trigger signal is ignored.	

# TIME DELAY RELAYS

Non-Programmable Plug-in  
On Delay, Interval & Flasher



- u Each unit has a single timing range
- u Choose from 20 separate timing ranges from 0.02 Seconds to 24 Hours
- u Uses industry-standard 8 pin octal sockets
- u 10A DPDT output contacts



## SINGLE KNOB UNITS

FUNCTION n	INPUT VOLTAGE 50/60Hz.	PRODUCT NUMBER ** <small>COMPLETE PRODUCT NUMBER USING 2 DIGIT CODE FROM TABLE BELOW</small>	WIRING/ SOCKETS p
ON DELAY	120V AC/DC 12V AC/DC 24V AC/DC 240V AC	TR-50222-** TR-50226-** TR-50228-** TR-50221-**	8 PIN OCTAL p <b>70169-D</b>  INPUT VOLTAGE <b>DIAGRAM 1</b>
INTERVAL ON	120V AC/DC 12V AC/DC 24V AC/DC 240V AC	TR-50522-** TR-50526-** TR-50528-** TR-50521-**	
FLASHER	120V AC/DC 12V AC/DC 24V AC/DC 240V AC	TR-50822-** TR-50826-** TR-50828-** TR-50821-**	

n See Pages 32-33 for definitions & explanations of Timing Functions.

p Note: if these products are ordered with the Remote Adjust Potentiometer modification (suffix -Rx), they will require an 11 pin octal socket—see Page 50 for more information.

**Sockets & Accessories**—Page 58  
**Dimensions**—Page 37

**Application Data**—Page 37  
**Standard Modifications**—Pages 50-51

## Timing Ranges

<b>** TIMING RANGE TABLE</b>			
COMPLETE PRODUCT NUMBER USING TWO DIGIT CODE FROM TABLE BELOW			
i.e., TR-50222-04			
Time Delay Range	Code	Time Delay Range	Code
0.02 - 2 Sec.	03	6 Sec. - 10 Min.	22
0.05 - 5 Sec.	04	9 Sec. - 15 Min.	14
0.1 - 10 Sec.	05	0.3 - 30 Min.	15
0.15 - 15 Sec.	06	0.6 - 60 Min.	16
0.3 - 30 Sec.	07	1.2 - 120 Min.	17
0.6 - 60 Sec.	08	1.8 - 180 Min.	18
1.2 - 120 Sec.	09	2.4 Min. - 4 Hr.	19
1.8 - 180 Sec.	10	4.8 Min. - 8 Hr.	20
3 - 300 Sec.	12	7.2 Min. - 12 Hr.	21
4.5 - 450 Sec.	13	14.4 Min. - 24 Hr.	23

For Fixed Time Delay (at no additional charge), add suffix "F" and time delay desired to basic Product Number, i.e., TR-50222-F5S is an On Delay with a time delay fixed at 5 seconds.



**800-238-7474**

[www.macromatic.com](http://www.macromatic.com)  
[whats-up@macromatic.com](mailto:whats-up@macromatic.com)



# TIME DELAY RELAYS

Non-Programmable Plug-in  
Off Delay, Single Shot & Watchdog

## SINGLE KNOB UNITS

FUNCTION n p	INPUT VOLTAGE 50/60Hz.	PRODUCT NUMBER ** <small>COMPLETE PRODUCT NUMBER USING 2 DIGIT CODE FROM TABLE BELOW</small>	WIRING/ SOCKETS
<b>OFF DELAY</b> Control Switch Trigger	120V AC/DC 12V AC/DC 24V AC/DC 240V AC	TR-51622-** TR-51626-** TR-51628-** TR-51621-**	11 PIN OCTAL <b>70170-D</b>  <b>DIAGRAM 2</b>
<b>SINGLE SHOT</b> Control Switch Trigger	120V AC/DC 12V AC/DC 24V AC/DC 240V AC	TR-51522-** TR-51526-** TR-51528-** TR-51521-**	
<b>WATCHDOG</b> Control Switch Trigger (Retriggerable Single Shot)	120V AC/DC 12V AC/DC 24V AC/DC 240V AC	TR-51322-** TR-51326-** TR-51328-** TR-51321-**	
<b>OFF DELAY</b> Power Trigger	120V AC/DC 12V AC/DC 24V AC/DC 240V AC	TR-51922-** TR-51926-** TR-51928-** TR-51921-**	11 PIN OCTAL <b>70170-D</b>  <b>DIAGRAM 4</b>
<b>SINGLE SHOT</b> Power Trigger	120V AC/DC 12V AC/DC 24V AC/DC 240V AC	TR-51722-** TR-51726-** TR-51728-** TR-51721-**	
<b>WATCHDOG</b> Power Trigger (Retriggerable Single Shot)	120V AC/DC 12V AC/DC 24V AC/DC 240V AC	TR-51822-** TR-51826-** TR-51828-** TR-51821-**	

- u Each unit has a single timing range
- u Choose from 20 separate timing ranges from 0.02 Seconds to 24 Hours
- u Uses industry-standard 11 pin octal sockets
- u 10A DPDT output contacts



n See Pages 32-33 for definitions & explanations of Timing Functions.

p 8 Pin SPDT versions of these functions are available—see Page 38.

Sockets & Accessories—Page 58

Application Data—Page 37

Dimensions—Page 37

Standard Modifications—Pages 50-51

## Timing Ranges

<b>** TIMING RANGE TABLE</b>			
COMPLETE PRODUCT NUMBER USING TWO DIGIT CODE FROM TABLE BELOW			
i.e., TR-51622-04			
Time Delay Range	Code	Time Delay Range	Code
0.02 - 2 Sec.	03	6 Sec. - 10 Min.	22
0.05 - 5 Sec.	04	9 Sec. - 15 Min.	14
0.1 - 10 Sec.	05	0.3 - 30 Min.	15
0.15 - 15 Sec.	06	0.6 - 60 Min.	16
0.3 - 30 Sec.	07	1.2 - 120 Min.	17
0.6 - 60 Sec.	08	1.8 - 180 Min.	18
1.2 - 120 Sec.	09	2.4 Min. - 4 Hr.	19
1.8 - 180 Sec.	10	4.8 Min. - 8 Hr.	20
3 - 300 Sec.	12	7.2 Min. - 12 Hr.	21
4.5 - 450 Sec.	13	14.4 Min. - 24 Hr.	23

For Fixed Time Delay (at no additional charge), add suffix "F" and time delay desired to basic Product Number, i.e., TR-51622-F5S is an Off Delay with a time delay fixed at 5 seconds.



**800-238-7474**

[www.macromatic.com](http://www.macromatic.com)  
[whats-up@macromatic.com](mailto:whats-up@macromatic.com)

# TIME DELAY RELAYS

Non-Programmable Plug-in  
Repeat Cycle & Delayed Interval

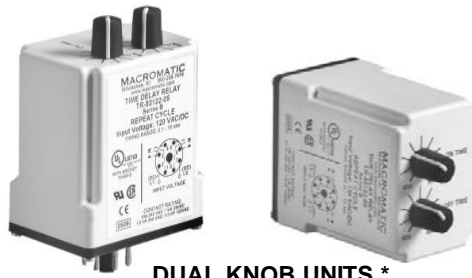

**DUAL KNOB UNITS \***

- Each unit has a single timing range
- Choose from 20 separate timing ranges from 0.02 Seconds to 24 Hours
- Independently adjustable ON & OFF times on dual knob timers
- Uses industry-standard 8 or 11 pin octal sockets
- 10A DPDT output contacts



**UL LISTED** with appropriate socket

FUNCTION n	INPUT VOLTAGE 50/60Hz.	PRODUCT NUMBER ** COMPLETE PRODUCT NUMBER USING 2 DIGIT CODE FROM TABLE BELOW	WIRING/SOCKET
<b>REPEAT CYCLE</b> (OFF Time First Followed By ON Time and Repeating)	120V AC/DC 12V AC/DC 24V AC/DC 240V AC	TR-53122-** TR-53126-** TR-53128-** TR-53121-**	8 PIN OCTAL <b>70169-D</b>  INPUT VOLTAGE <b>DIAGRAM 1</b>
<b>REPEAT CYCLE</b> (ON Time First Followed By OFF Time and Repeating)	120V AC/DC 12V AC/DC 24V AC/DC 240V AC	TR-55122-** TR-55126-** TR-55128-** TR-55121-**	 INPUT VOLTAGE <b>DIAGRAM 1</b>
<b>DELAYED INTERVAL</b> (OFF Time Followed by ON Time Followed by OFF State Until Reset)	120V AC/DC 12V AC/DC 24V AC/DC 240V AC	TR-56122-** TR-56126-** TR-56128-** TR-56121-**	 INPUT VOLTAGE <b>DIAGRAM 1</b>
<b>DELAYED INTERVAL</b> Control Switch Trigger (OFF Time Followed by ON Time Followed by OFF State Until Reset)	120V AC/DC 12V AC/DC 24V AC/DC 240V AC	TR-56522-** TR-56526-** TR-56528-** TR-56521-**	11 PIN OCTAL <b>70170-D</b>  INPUT VOLTAGE <b>DIAGRAM 2</b>

\* All Dual Knob units have independently selectable & adjustable ON & OFF times. To order a Dual Knob unit with the same ON & OFF timing ranges, complete the Product Number by adding one two-digit code from the table below, i.e., a TR-55122-08 is a Repeat Cycle unit with both the ON time & OFF time adjustable between 0.6 - 60 seconds. To order a Dual Knob unit with different ON & OFF timing ranges, complete the Product Number by adding two different two-digit codes from the table below. The first suffix indicates the first timing range of the unit and the second suffix indicates the second timing range, i.e., a TR-53122-05-12 is a Repeat Cycle unit with an OFF timing range first of 0.1-10 seconds and an ON timing range second of 3-300 seconds.

n See Pages 32-33 for definitions & explanations of Timing Functions.

**Sockets & Accessories**—Page 58

**Application Data**—Page 37

**Dimensions**—Page 37

**Standard Modifications**—Pages 50-51

## Timing Ranges

<b>** TIMING RANGE TABLE</b>			
COMPLETE PRODUCT NUMBER USING TWO DIGIT CODE FROM TABLE BELOW			
i.e., TR-55122-04			
Time Delay Range	Code	Time Delay Range	Code
0.02 - 2 Sec.	03	6 Sec. - 10 Min.	22
0.05 - 5 Sec.	04	9 Sec. - 15 Min.	14
0.1 - 10 Sec.	05	0.3 - 30 Min.	15
0.15 - 15 Sec.	06	0.6 - 60 Min.	16
0.3 - 30 Sec.	07	1.2 - 120 Min.	17
0.6 - 60 Sec.	08	1.8 - 180 Min.	18
1.2 - 120 Sec.	09	2.4 Min. - 4 Hr.	19
1.8 - 180 Sec.	10	4.8 Min. - 8 Hr.	20
3 - 300 Sec.	12	7.2 Min. - 12 Hr.	21
4.5 - 450 Sec.	13	14.4 Min. - 24 Hr.	23

For Fixed Time Delay (at no additional charge), add suffix "F" and time delay desired to basic Product Number, i.e., TR-53122-F5S is a Repeat Cycle with a time delay fixed at 5 seconds.



**800-238-7474**

[www.macromatic.com](http://www.macromatic.com)

[whats-up@macromatic.com](mailto:whats-up@macromatic.com)

# TIME DELAY RELAYS

## Non-Programmable Plug-in Application Data & Dimensions

### Application Data

#### Voltage Tolerance:

AC Operation: +10/-15% of nominal at 50/60 Hz.

DC Operation: +10/-15% of nominal.

#### Load (Burden):

2 VA

#### Setting Accuracy:

Maximum Setting (Adjustable): +5%, -0%

Minimum Setting (Adjustable): +0%, -50%

Fixed Time Delay: > 2 Seconds ±1%  
0.1 - 2 Seconds ±5%

#### Repeat Accuracy (constant voltage and temperature):

> 2 Seconds Delay ±0.1%

0.1 - 2 Seconds Delay ±2%

#### Reset Time:

On Delay/Interval/Repeat Cycle/Delayed Interval: 0.1 Seconds

Off Delay/Single Shot/Watchdog/

Triggered Delayed Interval: 0.04 Seconds

#### Start-up Time:

(Time from when power is applied until unit is timing)

120 & 240V units 0.05 Seconds

12, 24 & 48V units 0.08 Seconds

#### Maintain Function Time:

(Time unit continues to time after power is removed)

0.01 Seconds for all units

#### Temperature:

12-120V Input Voltage: -28° to 65°C (-18° to 150°F)

240V Input Voltage: -28° to 50°C (-18° to 122°F)

#### Insulation Voltage:

2,000 volts

#### Output Contacts:

DPDT 10A @ 240V AC/28V DC,

1/2HP @ 240V AC, 1/3HP @ 120V AC

B300 & R300; AC15 & DC13

#### Life:

Mechanical: 10,000,000 operations

Full Load: 100,000 operations

#### Compatibility:

On all units triggered by input voltage or by a control switch, do not use a solid state switch to initiate the timing sequence—problems with leakage current could occur. On all units with a power trigger, do not use a solid state switch with leakage current exceeding 0.5ma. Contact Macromatic Controls for additional information.

#### Triggering Off Delay, Single Shot or Watchdog Units:

Timing sequence must be initiated only after input voltage is applied to unit. Minimum required trigger switch closure time is 0.1 seconds.

#### Approvals:



File #E109466



File #LR45565



Low Voltage &  
EMC Directives  
EN60947-1, EN60947-5-1



IND. CONT. EQUIP.  
5007  
with  
appropriate  
socket  
File #E109466

### Dimensions

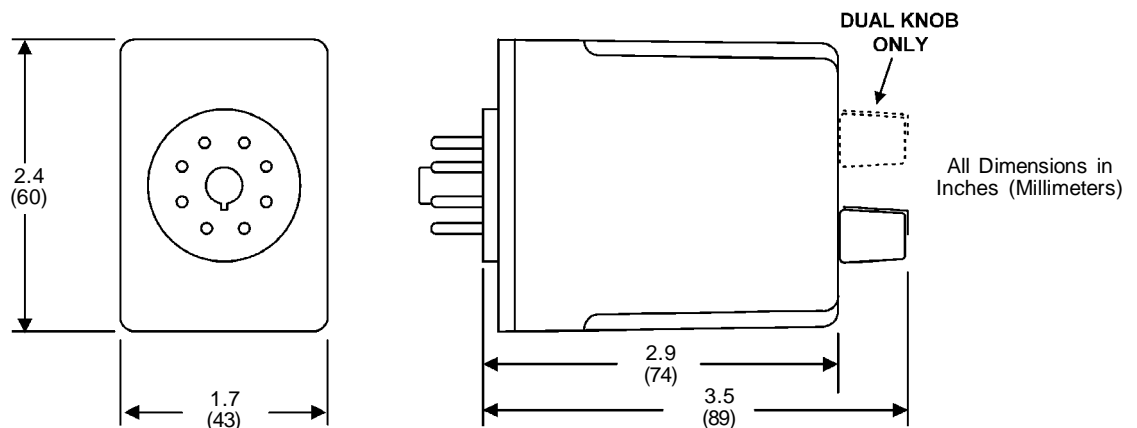

# TIME DELAY RELAYS

Non-Programmable Plug-in  
8 Pin SPDT Versions  
Off Delay, Single Shot & Watchdog



- These are 8 pin 10A SPDT versions of our standard 11 pin DPDT products
- Each unit has a single timing range from 0.02 Seconds to 24 Hours
- Uses industry-standard 8 pin octal socket



FUNCTION n	INPUT VOLTAGE 50/60Hz.	PRODUCT NUMBER ** <small>COMPLETE PRODUCT NUMBER USING 2 DIGIT CODE FROM TABLE BELOW</small>	WIRING/ SOCKETS p
<b>OFF DELAY</b> Control Switch Trigger	120V AC/DC 12V AC/DC 24V AC/DC 240V AC	TR-51662-** TR-51666-** TR-51668-** TR-51661-**	<b>8 PIN OCTAL 70169-D p</b>  CONTROL SWITCH (DC)+ L1 (DC)- L2 INPUT VOLTAGE <b>DIAGRAM 11</b>
<b>SINGLE SHOT</b> Control Switch Trigger	120V AC/DC 12V AC/DC 24V AC/DC 240V AC	TR-51562-** TR-51566-** TR-51568-** TR-51561-**	
<b>WATCHDOG</b> Control Switch Trigger (Retriggerable Single Shot)	120V AC/DC 12V AC/DC 24V AC/DC 240V AC	TR-51362-** TR-51366-** TR-51368-** TR-51361-**	
<b>OFF DELAY</b> Power Trigger	120V AC/DC 12V AC/DC 24V AC/DC 240V AC	TR-51962-** TR-51966-** TR-51968-** TR-51961-**	<b>8 PIN OCTAL 70169-D p</b>  POWER TRIGGER * (DC)+ L1 (DC)- L2 INPUT VOLTAGE * SHOULD BE SAME VOLTAGE AS INPUT VOLTAGE <b>DIAGRAM 37</b>
<b>SINGLE SHOT</b> Power Trigger	120V AC/DC 12V AC/DC 24V AC/DC 240V AC	TR-51762-** TR-51766-** TR-51768-** TR-51761-**	
<b>WATCHDOG</b> Power Trigger (Retriggerable Single Shot)	120V AC/DC 12V AC/DC 24V AC/DC 240V AC	TR-51862-** TR-51866-** TR-51868-** TR-51861-**	

n See Pages 32-33 for definitions & explanations of Timing Functions.

p Note: if these products are ordered with the Remote Adjust Potentiometer modification (suffix -Rx), they will require an 11 pin octal socket—see Page 50 for more information.

**Sockets & Accessories**—Page 58  
**Dimensions**—Page 39

**Application Data**—Page 39  
**Standard Modifications**—Pages 50-51

## Timing Ranges

<b>** TIMING RANGE TABLE</b>			
COMPLETE PRODUCT NUMBER USING TWO DIGIT CODE FROM TABLE BELOW			
i.e., TR-51662-04			
Time Delay Range	Code	Time Delay Range	Code
0.02 - 2 Sec.	03	6 Sec. - 10 Min.	22
0.05 - 5 Sec.	04	9 Sec. - 15 Min.	14
0.1 - 10 Sec.	05	0.3 - 30 Min.	15
0.15 - 15 Sec.	06	0.6 - 60 Min.	16
0.3 - 30 Sec.	07	1.2 - 120 Min.	17
0.6 - 60 Sec.	08	1.8 - 180 Min.	18
1.2 - 120 Sec.	09	2.4 Min. - 4 Hr.	19
1.8 - 180 Sec.	10	4.8 Min. - 8 Hr.	20
3 - 300 Sec.	12	7.2 Min. - 12 Hr.	21
4.5 - 450 Sec.	13	14.4 Min. - 24 Hr.	23

**For Fixed Time Delay** (at no additional charge), add suffix "F" and fixed time delay desired to basic Product Number, i.e., TR-51662-F5S is an Off Delay with a time delay fixed at 5 seconds.



**800-238-7474**

[www.macromatic.com](http://www.macromatic.com)  
[whats-up@macromatic.com](mailto:whats-up@macromatic.com)

# TIME DELAY RELAYS

Non-Programmable Plug-in  
8 Pin SPDT Versions

Application Data & Dimensions

## Application Data

### Voltage Tolerance:

AC Operation: +10/-15% of nominal at 50/60 Hz.

DC Operation: +10/-15% of nominal.

### Load (Burden):

2 VA

### Setting Accuracy:

Maximum Setting (Adjustable): +5%, -0%

Minimum Setting (Adjustable): +0%, -50%

Fixed Time Delay: > 2 Seconds ±1%

0.1 - 2 Seconds ±5%

### Repeat Accuracy (constant voltage and temperature):

> 2 Seconds Delay ±0.1%

0.1 - 2 Seconds Delay ±2%

### Reset Time:

Off Delay/Single Shot/Watchdog: 0.04 Seconds

### Start-up Time:

(Time from when power is applied until unit is timing)

120 & 240V units 0.05 Seconds

12, 24 & 48V units 0.08 Seconds

### Maintain Function Time:

(Time unit continues to time after power is removed)

0.01 Seconds for all units

### Temperature:

12-120V Input Voltage: -28° to 65°C (-18° to 150°F)

240V Input Voltage: -28° to 50°C (-18° to 122°F)

### Insulation Voltage:

2,000 volts

### Output Contacts:

DPDT 10A @ 240V AC/28V DC,

1/2HP @ 240V AC, 1/3HP @ 120V AC

B300 & R300; AC15 & DC13

### Life:

Mechanical: 10,000,000 operations

Full Load: 100,000 operations

### Compatibility:

On all units triggered by a control switch, do not use a solid state switch to initiate the timing sequence-problems with leakage current could occur. On all units with a power trigger, do not use a solid state switch with leakage current exceeding 0.5ma. Contact Macromatic Controls for additional information.

### Triggering Off Delay, Single Shot or Watchdog Units:

Timing sequence must be initiated only after input voltage is applied to unit. Minimum required trigger switch closure time is 0.1 seconds.

### Approvals:



File #E109466



File #LR45565



Low Voltage &  
EMC Directives  
EN60947-1, EN60947-5-1



IND. CONT. EQUIP.  
5017  
with  
appropriate  
socket  
File #E109466

## Dimensions

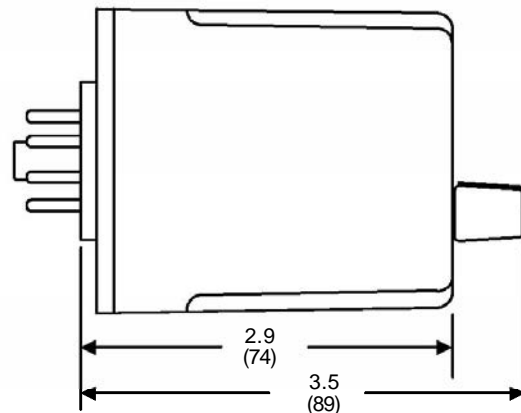
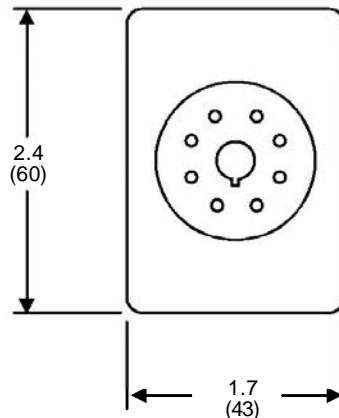

All Dimensions in  
Inches (Millimeters)

# TIME DELAY RELAYS

*Time Ranger*™ Programmable  
Multi-Range Plug-in  
On Delay, Interval On & Flasher



- Each unit has 16 timing ranges built-in
- Selecting a range is easy using a rotary switch (no math is required or DIP switches to set)
- Timing ranges up to 2 hours
- Uses industry-standard 8 pin octal sockets
- 10A DPDT output contacts



### SINGLE KNOB UNITS

FUNCTION	INPUT VOLTAGE 50/60Hz.	PRODUCT NUMBER	WIRING/ SOCKETS
<b>ON DELAY</b>	120V AC/DC 12V AC/DC 24V AC/DC 240V AC	TR-60222 TR-60226 TR-60228 TR-60221	<b>8 PIN OCTAL 70169-D</b>  <b>DIAGRAM 1</b>
<b>INTERVAL ON</b>	120V AC/DC 12V AC/DC 24V AC/DC 240V AC	TR-60522 TR-60526 TR-60528 TR-60521	
<b>FLASHER</b>	120V AC/DC 12V AC/DC 24V AC/DC 240V AC	TR-60822 TR-60826 TR-60828 TR-60821	

See Pages 32-33 for definitions & explanations of Timing Functions.

**Sockets & Accessories**—Page 58  
**Dimensions**—Page 43

**Application Data**—Page 43  
**Standard Modifications**—Pages 50-51

### Timing Ranges

Select one of the 16 built-in time ranges by setting the rotary switch per a chart on the unit and adjust within that range using the knob on top:

#### SINGLE KNOB UNITS

Dial Setting	Timing Range
A	0.1 - 0.25 Sec.
B	0.2 - 0.5 Sec.
C	0.3 - 1 Sec.
D	0.5 - 2 Sec.
E	1 - 4 Sec.
F	2 - 8 Sec.
G	4 - 15 Sec.
H	8 - 30 Sec.
I	15 - 60 Sec.
J	30 - 120 Sec.
K	1 - 4 Min.
L	2 - 8 Min.
M	4 - 15 Min.
N	8 - 30 Min.
O	15 - 60 Min.
P	30 - 120 Min.



**800-238-7474**

[www.macromatic.com](http://www.macromatic.com)  
[whats-up@macromatic.com](mailto:whats-up@macromatic.com)



# TIME DELAY RELAYS

*Time Ranger™* Programmable  
Multi-Range Plug-in  
Off Delay, Single Shot & Watchdog



## SINGLE KNOB UNITS

FUNCTION <sup>n</sup>	INPUT VOLTAGE 50/60Hz.	PRODUCT NUMBER	WIRING/ SOCKETS
<b>OFF DELAY</b> Control Switch Trigger	120V AC/DC	TR-61622	<p><b>DIAGRAM 2</b></p>
	12V AC/DC	TR-61626	
	24V AC/DC	TR-61628	
	240V AC	TR-61621	
<b>SINGLE SHOT</b> Control Switch Trigger	120V AC/DC	TR-61522	<p><b>DIAGRAM 2</b></p>
	12V AC/DC	TR-61526	
	24V AC/DC	TR-61528	
	240V AC	TR-61521	
<b>WATCHDOG</b> Control Switch Trigger (Retriggerable Single Shot)	120V AC/DC	TR-61322	<p><b>DIAGRAM 2</b></p>
	12V AC/DC	TR-61326	
	24V AC/DC	TR-61328	
	240V AC	TR-61321	
<b>OFF DELAY</b> Power Trigger	120V AC/DC	TR-61922	<p><b>DIAGRAM 4</b></p>
	12V AC/DC	TR-61926	
	24V AC/DC	TR-61928	
	240V AC	TR-61921	
<b>SINGLE SHOT</b> Power Trigger	120V AC/DC	TR-61722	<p><b>DIAGRAM 4</b></p>
	12V AC/DC	TR-61726	
	24V AC/DC	TR-61728	
	240V AC	TR-61721	
<b>WATCHDOG</b> Power Trigger (Retriggerable Single Shot)	120V AC/DC	TR-61822	<p><b>DIAGRAM 4</b></p>
	12V AC/DC	TR-61826	
	24V AC/DC	TR-61828	
	240V AC	TR-61821	

- Each unit has 16 timing ranges built-in
- Selecting a range is easy using a rotary switch (no math is required or DIP switches to set)
- Timing ranges up to 2 hours
- Uses industry-standard 11 pin octal sockets
- 10A DPDT output contacts



<sup>n</sup> See Pages 32-33 for definitions & explanations of Timing Functions.

**Sockets & Accessories**—Page 58

**Application Data**—Page 43

**Dimensions**—Page 43

**Standard Modifications**—Pages 50-51

## Timing Ranges

Select one of the 16 built-in time ranges by setting the rotary switch per a chart on the unit and adjust within that range using the knob on top:

### SINGLE KNOB UNITS

Dial Setting	Timing Range
A	0.1 - 0.25 Sec.
B	0.2 - 0.5 Sec.
C	0.3 - 1 Sec.
D	0.5 - 2 Sec.
E	1 - 4 Sec.
F	2 - 8 Sec.
G	4 - 15 Sec.
H	8 - 30 Sec.
I	15 - 60 Sec.
J	30 - 120 Sec.
K	1 - 4 Min.
L	2 - 8 Min.
M	4 - 15 Min.
N	8 - 30 Min.
O	15 - 60 Min.
P	30 - 120 Min.



**800-238-7474**

[www.macromatic.com](http://www.macromatic.com)  
[whats-up@macromatic.com](mailto:whats-up@macromatic.com)

# TIME DELAY RELAYS

*Time Ranger*™ Programmable  
Multi-Range Plug-in  
Repeat Cycle & Delayed Interval



- Each unit has 16 timing ranges built-in
- Selecting a range is easy using a rotary switch (no math is required or DIP switches to set)
- Timing ranges up to 24 hours
- Independently selectable & adjustable ON & OFF times on dual knob timers
- Uses industry-standard 8 or 11 pin octal sockets
- 10A DPDT output contacts



## DUAL KNOB UNITS \*

FUNCTION n	INPUT VOLTAGE 50/60Hz.	PRODUCT NUMBER	WIRING/ SOCKETS
<b>REPEAT CYCLE</b> (OFF Time First Followed By ON Time and Repeating)	120V AC/DC	TR-63122	<b>8 PIN OCTAL</b> <b>70169-D</b>  INPUT VOLTAGE <b>DIAGRAM 1</b>
	12V AC/DC	TR-63126	
	24V AC/DC	TR-63128	
	240V AC	TR-63121	
<b>REPEAT CYCLE</b> (ON Time First Followed By OFF Time and Repeating)	120V AC/DC	TR-65122	<b>11 PIN OCTAL</b> <b>70170-D</b>  INPUT VOLTAGE <b>DIAGRAM 2</b>
	12V AC/DC	TR-65126	
	24V AC/DC	TR-65128	
	240V AC	TR-65121	
<b>DELAYED INTERVAL</b> (OFF Time Followed by ON Time Followed by OFF State Until Reset)	120V AC/DC	TR-66122	
	12V AC/DC	TR-66126	
	24V AC/DC	TR-66128	
	240V AC	TR-66121	
<b>DELAYED INTERVAL</b> Control Switch Trigger (OFF Time / ON Time / OFF State Until Reset)	120V AC/DC	TR-66522	
	12V AC/DC	TR-66526	
	24V AC/DC	TR-66528	
	240V AC	TR-66521	

\* All Dual Knob units have independently selectable & adjustable ON & OFF times.  
n See Pages 32-33 for definitions & explanations of Timing Functions.

**Sockets & Accessories**—Page 58

**Application Data**—Page 43

**Dimensions**—Page 43

**Standard Modifications**—Pages 50-51

### Timing Ranges

Select one of the 16 built-in time ranges by setting the rotary switch per a chart on the unit and adjust within that range using the knob on top:

#### DUAL KNOB UNITS

Dial Setting	Timing Range
A	0.6 - 2.5 Sec.
B	1.5 - 5 Sec.
C	2.5 - 10.5 Sec.
D	5 - 21 Sec.
E	10 - 42 Sec.
F	0.4 - 1.4 Min.
G	0.7 - 2.8 Min.
H	1.5 - 5.5 Min.
I	3 - 11 Min.
J	5.5 - 22.5 Min.
K	11 - 45 Min.
L	0.4 - 1.5 Hr.
M	0.8 - 3 Hr.
N	1.5 - 6 Hr.
O	3 - 12 Hr.
P	6 - 24 Hr.



**800-238-7474**

[www.macromatic.com](http://www.macromatic.com)  
[whats-up@macromatic.com](mailto:whats-up@macromatic.com)

# TIME DELAY RELAYS

*Time Ranger*™ Programmable  
Multi-Range Plug-in  
Application Data & Dimensions

## Application Data

### Voltage Tolerance:

AC Operation: +10/-15% of nominal at 50/60 Hz.

DC Operation: +10/-15% of nominal.

### Load (Burden):

2 VA

### Setting Accuracy:

Maximum Setting (Adjustable): +5%, -0%

Minimum Setting (Adjustable): +0%, -50%

### Repeat Accuracy (constant voltage and temperature):

> 2 Seconds Delay ±0.1%

0.1 - 2 Seconds Delay ±2%

### Reset Time:

On Delay/Interval/Repeat Cycle/Delayed Interval: 0.1 Seconds

Off Delay/Single Shot/Watchdog/

Triggered Delayed Interval: 0.04 Seconds

### Start-up Time:

(Time from when power is applied until unit is timing)

120 & 240V units 0.05 Seconds

12, 24 & 48V units 0.08 Seconds

### Maintain Function Time:

(Time unit continues to time after power is removed)

0.01 Seconds for all units

### Temperature:

12-120V Input Voltage: -28° to 65°C (-18° to 150°F)

240V Input Voltage: -28° to 50°C (-18° to 122°F)

### Insulation Voltage:

2,000 volts

### Output Contacts:

DPDT 10A @ 240V AC/28V DC,

1/2HP @ 240V AC, 1/3HP @ 120V AC

B300 & R300; AC15 & DC13

### Life:

Mechanical: 10,000,000 operations

Full Load: 100,000 operations

### Compatibility:

On all units triggered by input voltage or by a control switch, do not use a solid state switch to initiate the timing sequence—problems with leakage current could occur. On all units with a power trigger, do not use a solid state switch with leakage current exceeding 0.5ma. Contact Macromatic Controls for additional information.

### Triggering Off Delay, Single Shot or Watchdog Units:

Timing sequence must be initiated only after input voltage is applied to unit. Minimum required trigger switch closure time is 0.1 seconds.

### Approvals:



File #E109466



File #LR45565



Low Voltage &  
EMC Directives  
EN60947-1, EN60947-5-1



IND. CONT. EQUIP.  
SOUL  
with  
appropriate  
socket  
File #E109466

## Dimensions

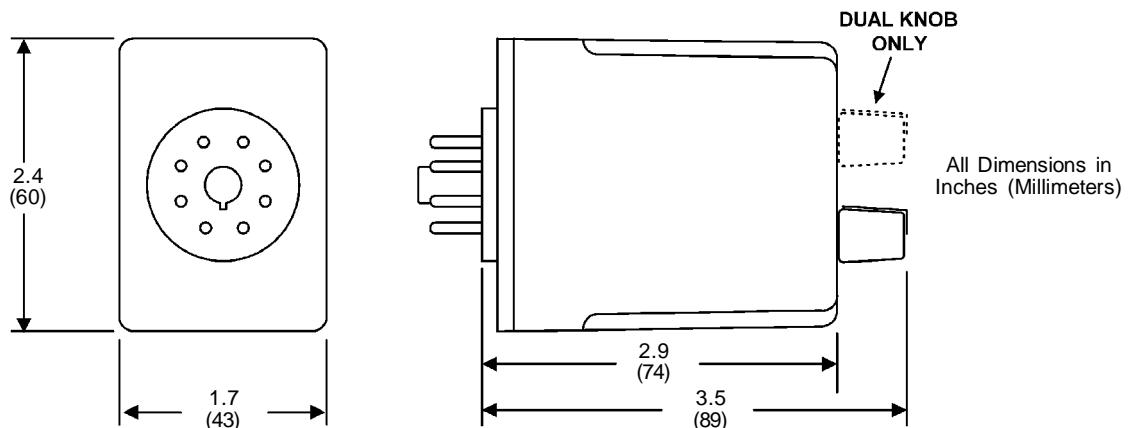

# TIME DELAY RELAYS

Compact Non-Programmable  
Plug-in

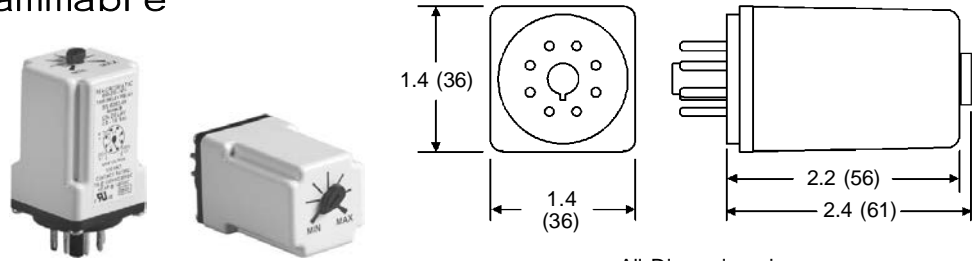

All Dimensions in  
Inches (Millimeters)

- Compact, economical design with standard features for basic applications
  - 6 separate timing ranges from 0.2 to 300 seconds
  - 5A SPDT output contacts
  - Uses industry-standard 8 pin octal sockets
- CULUS** LISTED  
with appropriate socket

## Timing Ranges

** TIMING RANGE TABLE	
COMPLETE PRODUCT NUMBER USING TWO DIGIT CODE FROM TABLE BELOW i.e., SS-6262-04	
Time Delay Range	Code
0.2 - 5 Sec.	04
0.5 - 15 Sec.	06
1 - 30 Sec.	07
2 - 60 Sec.	08
6 - 180 Sec.	10
10 - 300 Sec.	12

**For Fixed Time Delay:** (at no additional charge), add suffix "F" and time delay desired to basic Product Number, i.e., SS-6262-F5S is an On Delay fixed at 5 seconds.

FUNCTION	INPUT VOLTAGE	PRODUCT NUMBER ** <small>COMPLETE PRODUCT NUMBER USING 2 DIGIT CODE FROM TABLE BELOW LEFT</small>	WIRING/ SOCKET†
<b>ON DELAY</b>	120V AC 12V AC/DC 24V AC/DC	SS-6262-** SS-6266-** SS-6268-**	8 Pin Octal <b>70169-D</b>  INPUT VOLTAGE <b>DIAGRAM 5</b>
<b>INTERVAL ON</b>	120V AC 12V AC/DC 24V AC/DC	SS-8062-** SS-8066-** SS-8068-**	 INPUT VOLTAGE <b>DIAGRAM 5</b>
<b>OFF DELAY</b>	120V AC 12V AC/DC 24V AC/DC	SS-8562-** SS-8566-** SS-8568-**	8 Pin Octal <b>70169-D</b>  INPUT VOLTAGE <b>DIAGRAM 6</b>
<b>SINGLE SHOT</b>	120V AC 12V AC/DC 24V AC/DC	SS-8762-** SS-8766-** SS-8768-**	 INPUT VOLTAGE <b>DIAGRAM 6</b>

n See Pages 32-33 for definitions & explanations of Timing Functions.

l See Page 58 for **Sockets & Accessories**.

## Application Data

### Voltage Tolerance:

AC Operation: +10/-15% of nominal at 50/60 Hz.  
DC Operation: +10/-15% of nominal.

### Load (Burden):

Less than 3 VA

### Setting Accuracy:

Maximum Setting: +10%, -0%  
Minimum Setting: +0%, -50%  
Fixed Time Delay: > 2 Seconds ±2%  
0.1 - 2 Seconds ±5%

### Repeat Accuracy:

> 2 Seconds Delay ±2%  
0.1 - 2 Seconds Delay ±5%

### Reset Time:

0.2 Seconds

### Triggering Off Delay & Single Shot Units:

Timing sequence must be initiated only after input power is applied to unit. Minimum required trigger switch closure time is 0.1 seconds.

### Temperature:

0° to 60°C (32° to 140°F)

### Compatibility:

Do not use a solid state switch to initiate the timing sequence-problems with leakage current could occur. Contact Macromatic Controls for additional information.

### Transient Protection:

10,000 volts for 20 microseconds

### Output Contacts:

SPDT 5A Resistive @ 120V AC/  
28V DC, 1/6HP @ 120VAC

### Life:

Mechanical: 10,000,000 operations  
Full Load: 100,000 operations

### Approvals:

**CULUS** LISTED  
File #E109466 with appropriate socket



800-238-7474

www.macromatic.com  
whats-up@macromatic.com

# TIME DELAY RELAYS

Non-Programmable with Quick Connect Terminals

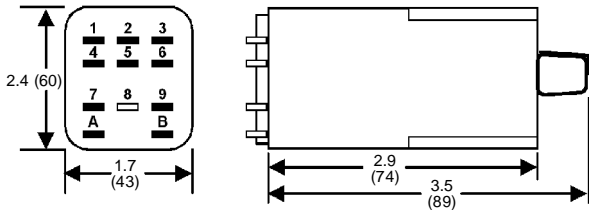

All Dimensions in Inches (Millimeters)



FUNCTION	INPUT VOLTAGE	TIME DELAY RANGE	PRODUCT NUMBER	WIRING/SOCKET
ON DELAY	120V AC/DC	0.1-10 Sec. 1-180 Sec. 3-300 Sec.	SS-40222-05 SS-40222-10 SS-40222-12	.187" Quick Connect <b>70171-D</b>  (DC) + L1 INPUT VOLTAGE (DC) L2 <b>DIAGRAM 25</b>
	24V AC/DC	0.1-10 Sec. 1-180 Sec. 3-300 Sec.	SS-40228-05 SS-40228-10 SS-40228-12	
OFF DELAY	120V AC/DC	0.1-10 Sec. 1-180 Sec. 3-300 Sec.	SS-41622-05 SS-41622-10 SS-41622-12	.187" Quick Connect <b>70171-D</b> CONTROL SWITCH  (DC) + L1 INPUT VOLTAGE (DC) L2 <b>DIAGRAM 26</b>
	24V AC/DC	0.1-10 Sec. 1-180 Sec. 3-300 Sec.	SS-41628-05 SS-41628-10 SS-41628-12	

- Industry-standard .187" quick connect terminals
- On Delay or Off Delay timing functions
- 3 separate timing ranges up to 300 seconds
- 12A DPDT output contacts



n See Pages 32-33 for definitions & explanations of Timing Functions.  
l See Page 58 for **Sockets & Accessories**

**For Fixed Time Delay:** (at no additional charge), add letter "F" and time delay desired to basic Product Number, i.e., SS-40222-F5S, is an On Delay with time delay fixed at 5 seconds.

## Application Data

### Voltage Tolerance:

AC Operation: +10/-15% of nominal at 50/60 Hz.  
DC Operation: +10/-15% of nominal.

### Load (Burden):

Less than 3 VA.

### Setting Accuracy:

Maximum Setting: +10%, -0%  
Minimum Setting: +0%, -50%  
Fixed Time Delay: > 2 Seconds ±2%  
0.1 - 2 Seconds ±5%

### Repeat Accuracy:

> 2 Seconds Delay ±2%  
0.1 - 2 Seconds Delay ±5%

### Compatibility:

On Off Delay units, do not use a solid state switch to initiate the timing sequence-problems with leakage current could occur. Contact Macromatic Controls for additional information.

**Recycle Time:** 0.1 Seconds

**Temperature:** -28° to 65°C (-20° to 150°F)

### Triggering Off Delay Timers:

Timing sequence must be initiated only after input power is applied to unit. Minimum required trigger switch closure time is 0.1 seconds.

### Transient Protection:

10,000 volts for 20 microseconds

### Output Contacts:

DPDT 12A Resistive @ 240V AC/  
30V DC, 1/2HP @240VAC

### Life:

Mechanical: 10,000,000 operations  
Full Load: 30,000 operations

### Approvals:



File #E109466



File #LR45565



Low Voltage & EMC Directives  
EN60947-1,  
EN60947-5-1



with appropriate socket



**800-238-7474**

[www.macromatic.com](http://www.macromatic.com)  
[whats-up@macromatic.com](mailto:whats-up@macromatic.com)

# TIME DELAY RELAYS

*Time Ranger*™ Digital -Set  
Programmable Multi-Range  
Plug-in



Multi-Function

Single-Function

- u Available in either Single-Function or Multi-Function versions (with five user-selectable modes)
- u Pushbutton Thumbwheels for digital set of time delay & function (TD-781 series only)
- u 50ms - 999 hour programmable time range
- u Uses industry-standard 8 or 11 pin octal sockets
- u 10A DPDT output contacts
- u LED indicates timing mode and time out conditions



The TD-7 series of time delay relays offer an easy and accurate way to select any time delay between 50ms & 999 hours. Programming is accomplished by using a pushbutton thumbwheel to select one of seven built-in time ranges and three pushbutton thumbwheels to digitally set the time delay required. This method provides a greater setting accuracy than is found on other units with an analog potentiometer. An LED indicates timing mode and time out condition.

The TD-7 series comes in two versions: a single function product or a multi-function product. The TD-781 multi-function unit has a fifth pushbutton thumbwheel to select one of five built-in functions.

### Multi-Function Product

FUNCTION	INPUT VOLTAGE	PRODUCT NUMBER	WIRING/ SOCKETS
<b>MULTI-FUNCTION</b> (5 Field-Selectable Functions in one unit) <ul style="list-style-type: none"> <li>u On Delay</li> <li>u Off Delay</li> <li>u Interval On</li> <li>u Single Shot</li> <li>u Flasher</li> </ul>	120V AC/DC	TD-78122	11 PIN OCTAL <b>70170-D</b>  DIAGRAM 121
	12V AC/DC	TD-78126	
	24V AC/DC	TD-78128	
	240V AC	TD-78121	

### Single Function Products

FUNCTION	INPUT VOLTAGE	PRODUCT NUMBER	WIRING/ SOCKETS
<b>ON DELAY</b>	120V AC/DC	TD-70222	8 PIN OCTAL <b>70169-D</b>  DIAGRAM 1
	12V AC/DC	TD-70226	
	24V AC/DC	TD-70228	
	240V AC	TD-70221	
<b>INTERVAL ON</b>	120V AC/DC	TD-70522	8 PIN OCTAL <b>70169-D</b>  DIAGRAM 1
	12V AC/DC	TD-70526	
	24V AC/DC	TD-70528	
	240V AC	TD-70521	
<b>FLASHER</b>	120V AC/DC	TD-70822	8 PIN OCTAL <b>70169-D</b>  DIAGRAM 1
	12V AC/DC	TD-70826	
	24V AC/DC	TD-70828	
	240V AC	TD-70821	
<b>OFF DELAY</b>	120V AC/DC	TD-71622	11 PIN OCTAL <b>70170-D</b>  DIAGRAM 2
	12V AC/DC	TD-71626	
	24V AC/DC	TD-71628	
	240V AC	TD-71621	
<b>SINGLE SHOT</b>	120V AC/DC	TD-71522	11 PIN OCTAL <b>70170-D</b>  DIAGRAM 2
	12V AC/DC	TD-71526	
	24V AC/DC	TD-71528	
	240V AC	TD-71521	



800-238-7474

www.macromatic.com  
whats-up@macromatic.com

# TIME DELAY RELAYS

## *Time Ranger*™ Digital -Set Programmable Multi-Range Plug-in Application Data & Dimensions

### Application Data

**Voltage Tolerance:**

AC Operation: +10/-15% of nominal at 50/60 Hz.  
DC Operation: +10/-15% of nominal.

**Load (Burden):**

3 VA

**Setting Accuracy:**

±1% of set time or ±50ms, whichever is greater.

**Repeat Accuracy** (constant voltage and temperature):

±0.1% of set time or ±0.02 seconds, whichever is greater.

**Reset Time:**

On Delay/Interval/Flasher: 0.1 Seconds  
Off Delay/Single Shot: 0.04 Seconds

**Start-up Time:**

(Time from when power is applied until unit is timing)  
120 & 240V units 0.05 Seconds  
12, 24 & 48V units 0.08 Seconds

**Maintain Function Time:**

(Time unit continues to time after power is removed)  
0.01 Seconds for all units

**Temperature:**

12-120V Input Voltage: -28° to 65°C (-18° to 150°F)  
240V Input Voltage: -28° to 50°C (-18° to 122°F)

**Insulation Voltage:**

2,000 volts

**Output Contacts:**

DPDT 10A @ 240V AC/28V DC,  
1/2HP @ 240V AC, 1/3HP @ 120V AC  
B300 & R300; AC15 & DC13

**Life:**

Mechanical: 10,000,000 operations  
Full Load: 100,000 operations

**Compatibility:**

Do not use a solid state switch to initiate the timing sequence- problems with leakage current could occur. Contact Macro-matic Controls for additional information.

**Triggering Off Delay or Single Shot Units:**

Timing sequence must be initiated only after input voltage is applied to unit. Minimum required trigger switch closure time is 0.1 seconds.

**LED:**

Flasher Mode: Flashes during "ON" time; continuous on during "OFF" time

All Other Modes: Flashes during timing; continuous on after time out.

**Approvals:**

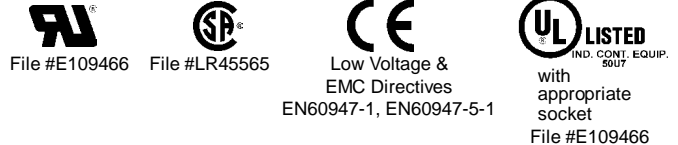

### Dimensions

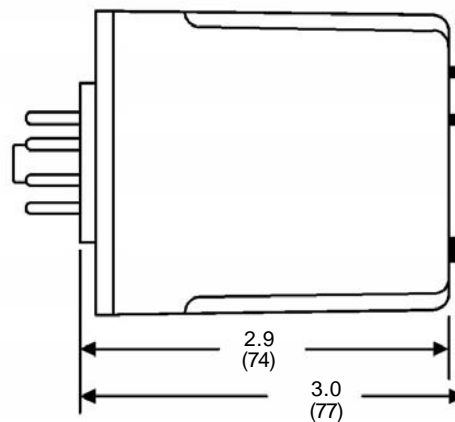
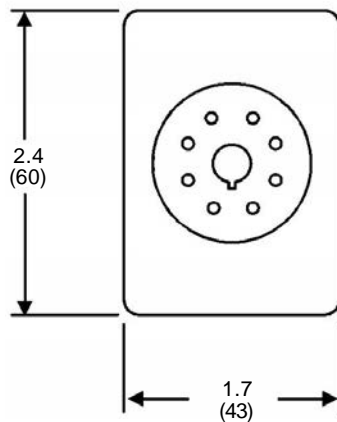

All Dimensions in Inches (Millimeters)

# TIME DELAY RELAYS

*Time Ranger*™ III  
 Digital -Set  
 Multi-Function  
 Multi-Range

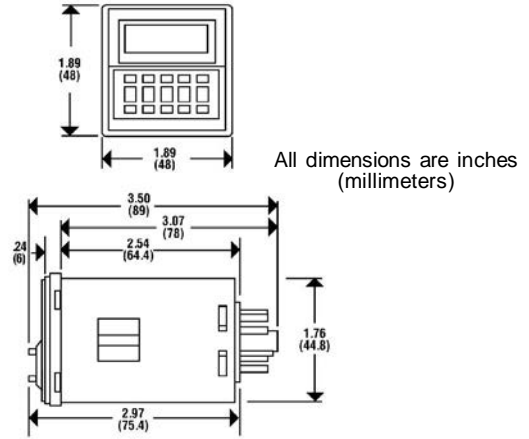

- u 8 field-selectable functions in one unit
- u Push-button thumbwheels for digital-setting of time delay
- u Universal AC/DC input voltage
- u LCD display
- u 0.1 Second to 9,990 Hours programmable timing range
- u Panel, track or surface mounting
- u 1/16 DIN style case
- u 3A SPDT output contacts



FUNCTION	INPUT VOLTAGE	PRODUCT NUMBER	WIRING/SOCKETS <sub>n</sub>
<b>8 FIELD-SELECTABLE FUNCTIONS</b> <sub>u</sub>	24-240V AC 50/60Hz & 12-240V DC	9816U1	<b>SEE DIAGRAMS ON PAGE 49</b> 11 Pin Octal

<sub>u</sub> Functions Include: On Delay, Flasher, Interval/Off Delay, Off Delay (2 Versions), Interval, Delayed Interval and On Delay/Off Delay (see Page 49 for Further Details)

<sub>n</sub> See below for **Sockets & Accessories**.

## Application Data

**Voltage Tolerance:**  
 ±10% of rated voltage.

**Load (Burden):**  
 Less than 3 VA

**Repeat Accuracy:**  
 ±0.3%, ±0.05 seconds (includes variation due to voltage and temperature changes).

**Setting Accuracy:**  
 ±0.5%, ±0.05 seconds maximum.

**Recycle Time:**  
 0.5 seconds maximum.

**Temperature:**  
 -10° to 55°C (14° to 131°F)

**Output Contacts:**  
 SPDT 3A Resistive @ 250V AC  
 SPDT 5A Resistive @ 28V DC

**Life:**  
 Mechanical: 10,000,000 operations  
 Full Load: 100,000 operations

**Approvals:**    
 File #E170213 File #LR701134

## Sockets & Accessories

DESCRIPTION	PRODUCT NUMBER
11 Pin Octal Socket (Surface or Track Mounting)	70170-Dn
11 Pin Octal Socket (Back Mounting)	70300
Panel Mounting Adaptor	70310
Protective Cover	70320

<sub>n</sub> See Page 58

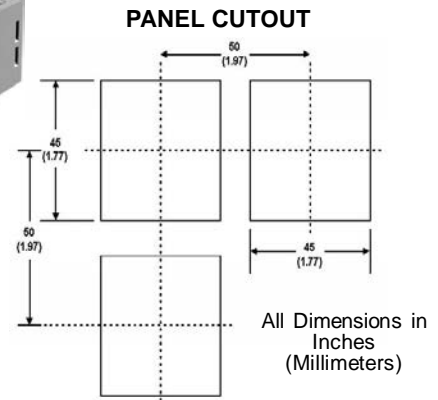
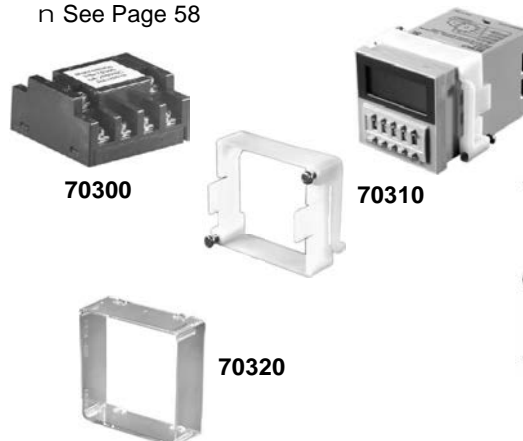

**800-238-7474**

[www.macromatic.com](http://www.macromatic.com)  
[whats-up@macromatic.com](mailto:whats-up@macromatic.com)



# TIME DELAY RELAYS

## Time Ranger™ III Digital -Set Multi-Function Multi-Range

FUNCTION		OPERATION		TIMING CHART
<b>MODE A</b> On-Delay	Standard (Diagram 7)	Standard	Upon application of control power, the preset time begins. At the end of the preset time, the relay contacts transfer. Control power must be removed and reapplied to reset the time delay relay.	
	Triggered (Diagram 9)	Triggered	Upon application of control power, the time delay relay is ready to accept trigger signals. Upon closure of the Start switch, the preset time begins. At the end of the preset time, the relay contacts transfer. Any closure of the Start switch is ignored until reset. The time delay relay is reset by closing the Reset switch or removing the control power.	
<b>MODE B</b> Flasher	Standard (Diagram 7)	Standard	Upon application of control power, the preset time begins. At the end of the preset time, the relay contacts transfer and remain in that condition for the preset time. At the end of this time, the relay contacts return to their normal condition and the sequence repeats until control power is removed.	
	Triggered (Diagram 9)	Triggered	Upon application of control power, the time delay relay is ready to accept trigger signals. Upon closure of the Start switch, the preset time begins. At the end of the preset time, the relay contacts transfer and remain in that condition for the preset time. At the end of this time, the relay contacts return to their normal condition and the sequence repeats until the Reset switch is closed or control power is removed.	
<b>MODE C</b> Interval/Off-Delay	(Diagram 8)	Standard	Upon application of control power, the time delay relay is ready to accept trigger signals. Upon closure or opening of the Start switch, the relay contacts transfer and the preset time begins. At the end of the preset time, the relay contacts return to their normal condition. Any closure or opening of the Start switch during timing causes the time to reset.	
<b>MODE D</b> Off-Delay (I)	(Diagram 8)	Standard	Upon application of control power, the time delay relay is ready to accept trigger signals. Upon closure of the Start switch, the relay contacts transfer and hold. Upon release of the Start switch, the preset time begins. At the end of the preset time, the relay contacts return to their normal condition. Any application of the Start switch will reset the time.	
<b>MODE E</b> Interval	Standard (Diagram 7)	Standard	Upon application of control power, the relay contacts transfer and the preset time begins. At the end of the preset time, the contacts return to their normal condition. Control power must be removed and reapplied to reset the time delay relay.	
	Triggered (Diagram 9)	Triggered	Upon application of control power, the time delay relay is ready to accept trigger signals. Upon closure of the Start switch, the relay contacts transfer and the preset time begins. At the end of the preset time, the contacts return to their normal condition. Any closure of the Start switch is ignored until reset. The time delay relay is reset by closing the Reset switch or removing the control power.	
<b>MODE F</b> Delayed Interval	Standard (Diagram 7)	Standard	Upon application of control power, the preset time begins. At the end of the preset time, the relay contacts transfer and remain in that condition for the preset time. At the end of this time, the relay contacts return to their normal condition and the sequence stops. Power must be removed and reapplied to reset the time delay relay.	
	Triggered (Diagram 9)	Triggered	Upon application of control power, the time delay relay is ready to accept trigger signals. At the end of the preset time, the relay contacts transfer and remain in that condition for the preset time. At the end of this time, the relay contacts return to their normal condition and the sequence stops. Power must be removed and reapplied to reset the time delay relay.	
<b>MODE G</b> On-Delay/Off-Delay	(Diagram 8)	Standard	Upon application of control power, the time delay relay is ready to accept trigger signals. Upon closure of the Start switch, the preset time begins. At the end of the preset time, the relay contacts will transfer. Upon opening of the Start switch, the preset time begins. At the end of the preset time, the output contacts return to their normal condition.	
<b>MODE H</b> Off-Delay (II)	(Diagram 8)	Standard	Upon application of control power, the time delay relay is ready to accept trigger signals. Closure of the Start switch is ignored. Upon release of the Start switch, the relay contacts transfer and the preset time begins. At the end of the preset time, the relay contacts return to their normal condition. Opening the Start switch during timing resets the time.	

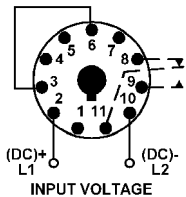

DIAGRAM 7

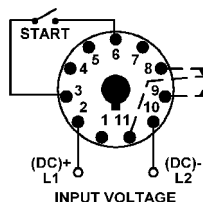

DIAGRAM 8

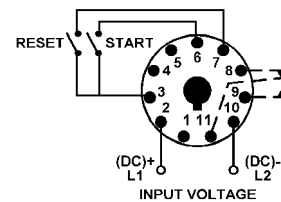

DIAGRAM 9

# TIME DELAY RELAYS

## Standard Modifications

All of our Catalog-Listed Time Delay Relays can be adapted for different applications. Below is a list of various Situations, Solutions and Ordering Information to illustrate many of these modifications. Please contact Macromatic if you have any questions or need additional information before ordering any products with these modifications.

**Situation:** I know exactly what time delay I need and therefore, do not need a unit with an adjustable time range.

**Solution:** Macromatic offers products where the adjustment potentiometer is removed and the unit comes with one specific (non-adjustable) time range, i.e., 5 seconds, 1 minute, etc. These are products with a "fixed" time delay.

**To order:** Any time delay relay fixed at a factory set delay time, replace the normal two digit suffix indicating adjustable time range with the suffix Fxxt where xx is the specific time delay desired and t is the time interval (seconds, minutes or hours), i.e., a TR-51622-F10S is an Off Delay fixed at 10 Seconds.

**Situation:** I have an 11 pin time delay relay where all the pins match the wiring diagram shown in your catalog (and below) except the control switch (trigger switch) is connected to pins other than pins 5 and 6.

**Solution:** Macromatic can build a time delay relay triggered by a control switch (i.e., Off Delay, Single Shot, Watchdog) with any pin configuration required to meet your application.

**To order:** Any time delay relay with a special control switch configuration, use the following chart to determine which suffix provides the correct configuration needed, i.e., a TR-51522-05T9 is a Single Shot with the control switch between pins 7 & 10 instead of 5 & 6:

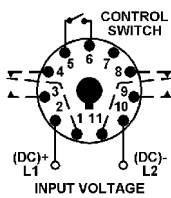

Standard 11 pin time delay relay, i.e., Off Delay, Single Shot, or Watchdog

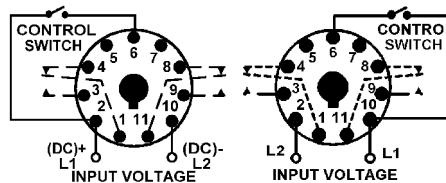

Standard 11 pin modified with a 2-6 control switch (Suffix T2)

Standard 11 pin modified with a 6-10 control switch (Suffix T8)

**NOTE:** The configuration of the input voltage and output contacts has not been changed.

Control Switch Connected To Pins	Add Suffix *	Control Switch Connected To Pins	Add Suffix *
2-5	T1	5-10	T6
2-6	T2	6-7	T7
2-7	T3	6-10	T8
5-7	T5	7-10	T9

\* **NOTE:** These suffixes apply only to different control switch pin configurations. The input voltage and output pin configurations remain as shown at left. For other configurations, contact Macromatic.

**Situation A:** I want to mount a time delay relay in an enclosure, but would like to adjust the time delay from outside the enclosure instead of having to open the door.

**Solution:** Macromatic can build most time delay relays with an optional remote adjustment feature. The potentiometer usually supplied with the product is removed, and the product is setup for use with a customer-supplied remote potentiometer to be connected to pins 5 & 7. Units that are normally 8 pin will have an 11 pin configuration. Units that are normally 11 pin will have the control switch connected between pins 2 & 6 (instead of the standard 5 & 6). For other control switch pin configurations, contact Macromatic for ordering information.

**To order:** Any time delay relay with a remote adjustment feature and an 11 pin pin header, use the following chart to determine which suffix matches the value of the remote potentiometer, i.e., a TR-50222-04R6 is an On Delay with an 11 pin header, setup for a 750K remote potentiometer to be connected to pins 5 & 7:

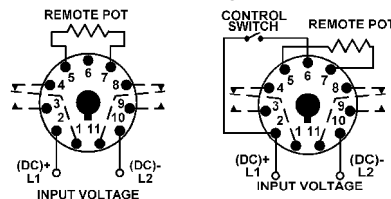

Normal 8 pin product with 11 pin configuration for Remote Adjust

Normal 11 pin product with configuration for Remote Adjust (2-6 Control Switch)

Remote Pot Value	Add Suffix	Remote Pot Value	Add Suffix
250K	R3	1.5M	R8
300K	R4	2M	R9
500K **	R5	2.5M	R10
750K	R6	5M	R11
1M	R7		

\*\* **NOTE:** A 500K potentiometer (R5) is the only value that can be used with a *Time Ranger* Programmable Time Delay Relay (those catalog numbers that begin with a TR-6).

# TIME DELAY RELAYS

## Standard Modifications

**Situation:** I want to use an 8 pin socket, but according to your catalog, the time delay relay I have selected is an 11 pin unit.

**Solution:** Macromatic can build any TR Series time delay relay that is normally an 11 pin product with an 8 pin base. This modified product will be SPDT only instead of the normal DPDT of the 11 pin version.

**To order:** See Page 38 for ordering information. **NOTE:** this option is available on TR Series products only.

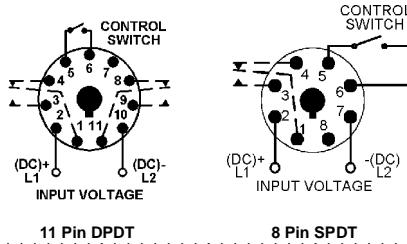

**Situation:** I have an 11 pin socket in place and wired, but according to your catalog, the time delay relay I want to use is an 8 pin unit.

**Solution:** Macromatic can build any time delay relay that is normally an 8 pin product with an 11 pin base.

**To order:** Any standard 8 Pin time delay relay modified to an 11 Pin base, add the suffix H to the end of the Product Number, i.e., a TR-60222-H is a programmable On Delay time delay relay with an 11 pin base configured as shown at left.

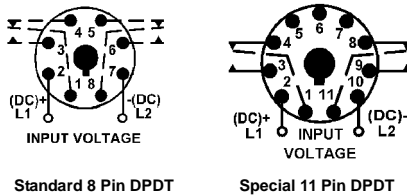

**Situation:** I need the time delay relay to recycle faster than the factory standard of 0.1 seconds.

**Solution:** A time delay relay with a fast reset of 0.05 seconds is available.

**To order:** Any time delay relay with a fast reset time, add the suffix N to the end of the Product Number, i.e., a TR-60222-N is an programmable On Delay with a fast reset time of 0.05 seconds.

**Situation:** I need a longer time delay range than the 2 hour maximum available on the Macromatic programmable *Time Ranger* single knob functions, i.e., On Delay, Interval On, Off Delay, etc.

**Solution:** Macromatic can modify our single knob programmable *Time Ranger* products that normally come with a 2 hour maximum setting to have a range of 0.6 seconds to 24 hours (same as our dual knob units).

**To order:** Any single knob programmable *Time Ranger* time delay relay with a 24 hour time range, add the suffix U to the end of the Product Number, i.e., a TR-60222-U would be an On Delay with a programmable time range of 0.6 seconds - 24 hours.

**Situation:** I have a power triggered time delay relay (Off Delay, Single Shot or Watchdog) with 120VAC input voltage, but would like to trigger it with a 5VDC computer generated voltage.

**Solution:** As standard, power triggered time delay relays must use the same voltage for both input voltage & trigger voltage. However, Macromatic offers an option on any power triggered unit to have a voltage different than the input voltage.

**To order:** Any time delay relay with a special power trigger voltage, use the following chart to determine which suffix provides the correct power trigger voltage, i.e., a TR-51922-05TV05 is a Power Triggered Off Delay with 120V input voltage and a 5V trigger voltage:

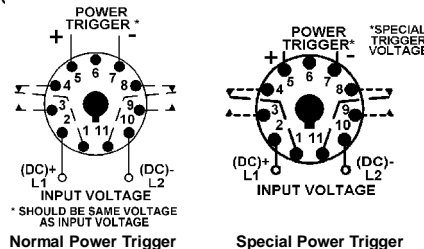

Voltage Input Needed (AC/DC)	Add Suffix
5	TV05
12	TV12
24	TV24
120	TV120
Other	Call Macromatic

**Situation:** The control switch used to initiate a time delay relay is a great distance from the product and I am experiencing problems triggering the relay.

**Solution:** Macromatic offers a long distance control switch option. This option will minimize the problems relating to noise that could caused false triggering of the time delay relay.

**To order:** Any time delay relay with a long distance control switch option, add the suffix Y to the end of the Product Number, i.e., a TR-61622-Y is a programmable Off Delay with a long distance control switch.

# ALTERNATING RELAYS

## SPDT & DPDT



- u For duplex loads
- u Can be used with one or two Control Switches
- u Control voltages of 12, 24, 120 & 240V AC
- u Compact plug-in design utilizing industry-standard 8 or 11 pin octal socket
- u 10A SPDT or DPDT Output Configuration
- u Optional low profile selector switch to lock in one sequence
- u 2 LED's indicate relay status



with appropriate socket

Alternating Relays are used in special applications where the optimization of load usage is required by equalizing the run time of two loads. This alternating action is initiated by a control switch, such as a float switch, manual switch, timing relay, pressure switch, or other isolated contact. Each time the initiating switch is opened, the output relay contacts will change state, thus alternating the two loads. Two LED indicators show the status of the output relay.

The Alternating Relays listed on this page can be used with one or two control switches & are available in either SPDT or DPDT output configurations (see "Typical Installations" on Page 53 for more information). For products with DPDT Cross-Wired output configurations to be used with one, two or three control switches, see Page 54.

Each version is available with an optional three position selector switch. This allows the unit to alternate the two loads as normal, or lock the relay to one load or the other. By locking the Alternating Relay to one load, the other load can be removed for service without rewiring the first load for continuous operation. The selector switch has a low profile to prevent any accidental changes in status.

OUTPUT CONTACTS	CONTROL VOLTAGE	PRODUCT NUMBER	WIRING/SOCKET <sup>n</sup>
<b>SPDT</b> w/o Selector Switch	12V AC 24V AC 120V AC 240V AC	ARP012A6 ARP024A6 ARP120A6 ARP240A6	<p><b>DIAGRAM 17</b></p> <p>LOAD A: PIN 2 LOAD B: PIN 8</p>
<b>SPDT</b> w/ Selector Switch	12V AC 24V AC 120V AC 240V AC	ARP012A6R ARP024A6R ARP120A6R ARP240A6R	
<b>DPDT</b> w/o Selector Switch	12V AC 24V AC 120V AC 240V AC	ARP012A2 ARP024A2 ARP120A2 ARP240A2	<p><b>DIAGRAM 18</b></p> <p>LOAD A: PINS 3 OR 11 LOAD B: PINS 1 OR 9</p>
<b>DPDT</b> w/ Selector Switch	12V AC 24V AC 120V AC 240V AC	ARP012A2R ARP024A2R ARP120A2R ARP240A2R	



800-238-7474

www.macromatic.com  
whats-up@macromatic.com

<sup>n</sup> See Page 58 for **Sockets & Accessories.**

# ALTERNATING RELAYS

## SPDT & DPDT

### Application Data & Dimensions

#### Application Data

**Voltage Tolerances:** +10%/-15% of control voltage at 50/60Hz.

**Load (Burden):** Less than 3VA

**Output Contacts:**

10A Resistive @ 240V AC/30V DC,  
1/2HP @ 120/240V AC (N.O.), 1/3HP @ 120/240VAC (N.C.)

**Life:**

Mechanical: 10,000,000 operations  
Full Load: 100,000 operations

**Temperature:** -28° to 65°C (-20° to 150°F)

**Transient Protection:** 10,000 volts for 20 microseconds

**Indicator LED's:** 2 LED's marked LOAD A and LOAD B

**Optional Selector Switch Settings:**

ALTERNATE  
LOCK LOAD A  
LOCK LOAD B

**Approvals:**



#### Dimensions

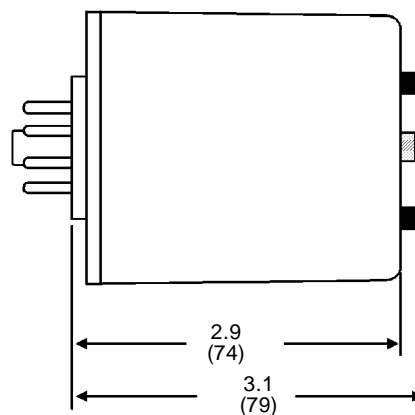
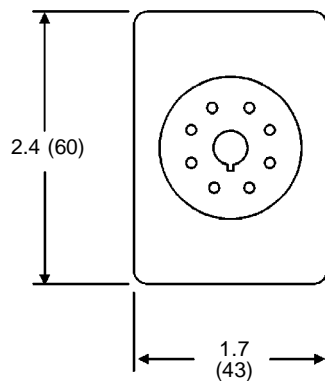

All Dimensions in Inches (Millimeters)

#### Typical Installations

In the off state (Figure A), the Control Switch is open, the Alternating Relay is in the LOAD A position, and both loads (M1 & M2) are off. When the Control Switch closes, it energizes the first load (M1). The red LED marked "LOAD A" glows. As long as the Control Switch remains closed, M1 remains energized. When the Control Switch opens, the first load (M1) is turned off and the Alternating Relay toggles to the LOAD B position. When the Control Switch closes again, it energizes the second load (M2). The red LED marked "LOAD B" glows. When the Control Switch opens, the second load (M2) is turned off, the Alternating Relay toggles back to the LOAD A position, and the process can be repeated again. On relays with DPDT contacts, two pilot lights can be used for remote indication of LOAD A or LOAD B status.

To eliminate any bounce condition of the Control Switch, the addition of a second switch (OFF) along with two auxiliary contacts is recommended as shown in Figure B.

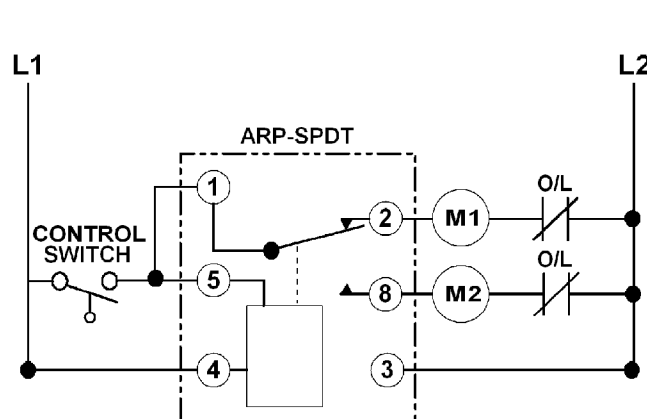

Figure A

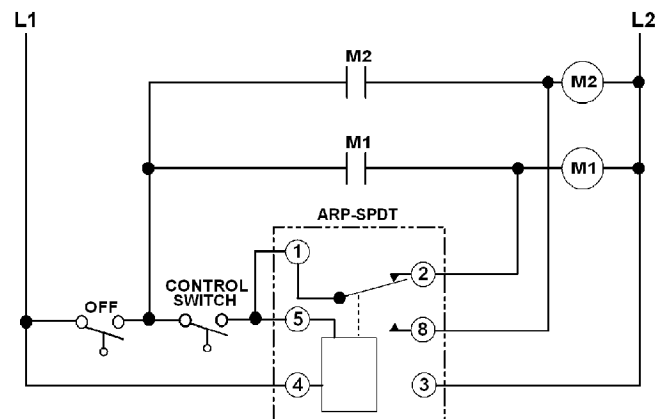

Figure B

# ALTERNATING RELAYS

## DPDT Cross-Wired



- u For duplex loads
- u Can be used with two or three Control Switches
- u Control voltages of 12, 24, 120 & 240V AC
- u Compact plug-in design utilizing industry-standard 8 pin octal socket
- u 10A DPDT Cross-Wired Output Configuration when additional capacity is required
- u Optional low profile selector switch to lock in one sequence
- u 2 LED's indicate relay status



with appropriate socket

Alternating Relays are used in special applications where the optimization of load usage is required by equalizing the run time of two loads. They are also used where additional capacity is required in case of excess load requirements. This alternating action is initiated by a control switch, such as a float switch, manual switch, timing relay, pressure switch, or other isolated contact. Each time the initiating switch is opened, the output relay contacts will change state, thus alternating the two loads. Two LED indicators show the status of the output relay.

The Alternating Relays listed on this page are available in DPDT Cross-Wired output configurations, and can be used with one, two or three control switches. See "Typical Installations" on Page 55 for more information. For products with SPDT or DPDT output configurations, see Page 52.

Each version is available with an optional three position selector switch. This allows the unit to alternate the two loads as normal, or lock the relay to one load or the other. By locking the Alternating Relay to one load, the other load can be removed for service without rewiring the first load for continuous operation. The selector switch has a low profile to prevent any accidental changes in status.

OUTPUT CONTACTS	CONTROL VOLTAGE	PRODUCT NUMBER	WIRING/SOCKET <sup>n</sup>
<b>DPDT CROSS-WIRED</b> w/o Selector Switch	12V AC 24V AC 120V AC 240V AC	ARP012A3 ARP024A3 ARP120A3 ARP240A3	<p>8 Pin Octal <b>70169-D</b></p> <p><b>DIAGRAM 19</b></p>
<b>DPDT CROSS-WIRED</b> w/ Selector Switch	12V AC 24V AC 120V AC 240V AC	ARP012A3R ARP024A3R ARP120A3R ARP240A3R	

<sup>n</sup> See Page 58 for **Sockets & Accessories**.



**800-238-7474**

[www.macromatic.com](http://www.macromatic.com)  
[whats-up@macromatic.com](mailto:whats-up@macromatic.com)

# ALTERNATING RELAYS

## DPDT Cross-Wired Application Data & Dimensions

### Application Data

**Voltage Tolerances:** +10%/-15% of control voltage at 50/60Hz.

**Load (Burden):** Less than 3VA

**Output Contacts:**

10A Resistive @ 240V AC/30V DC,  
1/2HP @ 120/240V AC (N.O.), 1/3HP @ 120/240VAC (N.C.)

**Life:**

Mechanical: 10,000,000 operations  
Full Load: 100,000 operations

**Temperature:** -28° to 65°C (-20° to 150°F)

**Transient Protection:** 10,000 volts for 20 microseconds

**Indicator LED's:** 2 LED's marked LOAD A and LOAD B

**Optional Selector Switch Settings:**

ALTERNATE  
LOCK LOAD A  
LOCK LOAD B

**Approvals:**

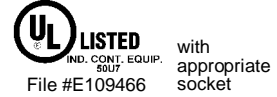

### Dimensions

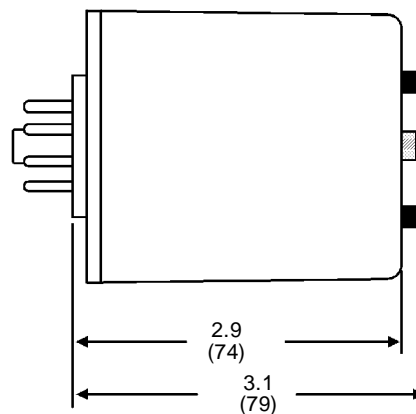
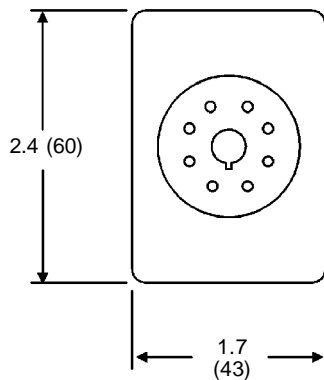

All Dimensions in Inches (Millimeters)

### Typical Installations

In the off state, both the LEAD Control Switch and the LAG Control Switch are open, the Alternating Relay is in the LOAD A position, and both loads are off. When the LEAD Control Switch closes, it energizes the first load (M1). The red LED marked "LOAD A" glows. As long as the LEAD Control Switch remains closed, M1 remains energized. If the LAG Control Switch closes, it energizes the second load (M2). When the LAG Control Switch opens, the second load (M2) is turned off. When the LEAD Control Switch opens, the first load (M1) is turned off and the Alternating Relay toggles to the LOAD B position. When the LEAD Control Switch closes, it turns on the second load (M2). The red LED marked "LOAD B" glows. If the LAG Control Switch closes, it will energize the first load (M1). When the LAG Control Switch opens, the first load (M1) is turned off. When the LEAD Control Switch opens, the second load (M2) is turned off, the Alternating Relay toggles back to the LOAD A position, and the process can be repeated again.

To eliminate any bounce condition of the Control Switch, the addition of a second switch (OFF) along with two auxiliary contacts is recommended as shown in Figure B.

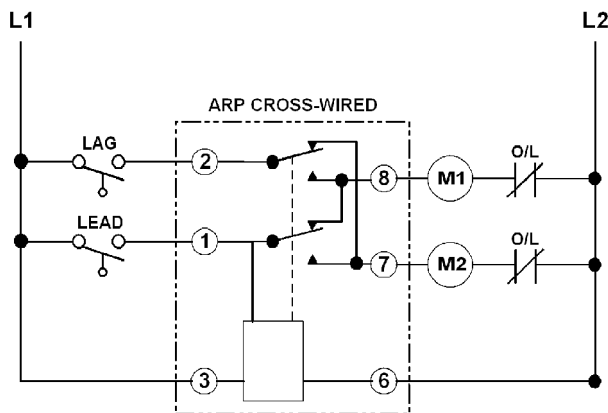

Figure A

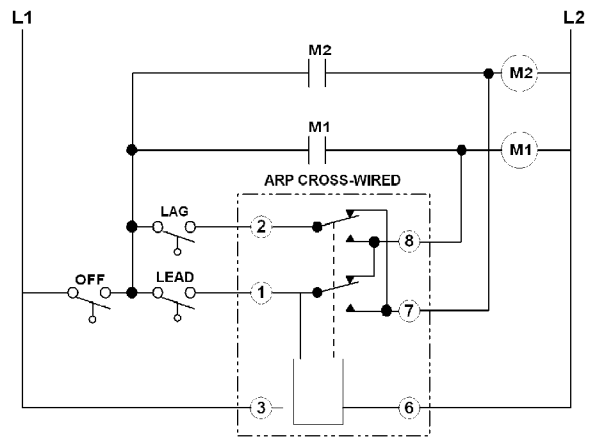

Figure B

# ALTERNATING RELAYS

For 3 Switch Applications  
(Lead-Lag-Stop)  
Sequence On-Simultaneous OFF



- u Works with 3 Control Switches - LEAD, LAG and STOP
- u Utilizes Sequence On - Simultaneously Off (S.O.S.O.) Operation
- u Replaces Separate Components in Duplex Panel, Saving Space and Reducing Labor
- u Protects against Failures of Both STOP & LEAD Switches
- u Control Voltages of 12, 24, 120 & 240V AC
- u Compact Plug-in Design Utilizing Industry-Standard 8 Pin Octal Socket
- u Optional low profile selector switch to lock in one sequence
- u 2 LED's indicate relay status



Macromatic Alternating Relays for Three Switch Applications offer a number of unique advantages over standard duplex units:

- l Combines standard DPDT cross-wired Alternating Relay, contactor auxiliary contacts and control relay into one compact & economical product, thus reducing the cost of the panel by saving space, reducing the number of components and minimizing assembly labor.
- l Works with three switches instead of just one or two – LEAD, LAG and STOP.
- l Sequence On - Simultaneous Off (S.O.S.O.) Operation – the two loads are energized sequentially, but remain on together until the STOP switch is opened.
- l Protects against failure of the STOP and LEAD switches – if both switches fail, the two pump motors will be energized simultaneously when the LAG switch is closed.

See "Typical Installations" on Page 57 for more information.

Alternating Relays from Macromatic are available with an optional three position selector switch. This allows the unit to alternate the two loads as normal, or lock the relay to one load or the other. By locking the Alternating Relay to one load, the other load can be removed for service without rewiring the first load for continuous operation. The selector switch has a low profile to prevent any accidental changes in status.

OUTPUT CONTACTS	CONTROL VOLTAGE	PRODUCT NUMBER	WIRING/SOCKET
<b>DPDT CROSS-WIRED</b> For 3 Switch Operation w/o Selector Switch	12V AC 24V AC 120V AC 240V AC	ARP012A8 ARP024A8 ARP120A8 ARP240A8	8 Pin Octal <b>70169-D</b>  <b>DIAGRAM 58</b>
<b>DPDT CROSS-WIRED</b> For 3 Switch Operation w/ Selector Switch	12V AC 24V AC 120V AC 240V AC	ARP012A8R ARP024A8R ARP120A8R ARP240A8R	

See Page 58 for **Sockets & Accessories**.



**800-238-7474**

[www.macromatic.com](http://www.macromatic.com)  
[whats-up@macromatic.com](mailto:whats-up@macromatic.com)



# ALTERNATING RELAYS

For 3 Switch Applications  
Application Data & Dimensions

## Application Data

**Voltage Tolerances:** +10%/-15% of control voltage at 50/60Hz.

**Load (Burden):** Less than 3VA

**Output Contacts:**

10A Resistive @ 240V AC/30V DC,  
1/2HP @ 120/240V AC (N.O.), 1/3HP @ 120/240VAC (N.C.)

**Life:**

Mechanical: 10,000,000 operations  
Full Load: 150,000 operations

**Temperature:** -28° to 65°C (-20° to 150°F)

**Transient Protection:** 10,000 volts for 20 microseconds

**Indicator LED's:** 2 LED's marked LOAD A and LOAD B

**Optional Selector Switch Settings:**

ALTERNATE  
LOCK LOAD A  
LOCK LOAD B

**Approvals:**



File #E109466



File #E109466

with appropriate socket

## Dimensions

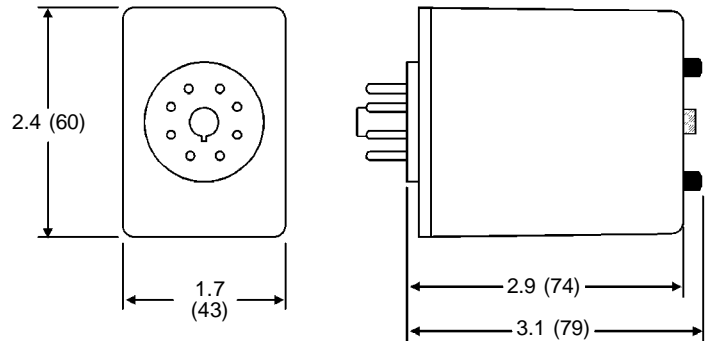

All Dimensions in Inches (Millimeters)

## Typical Installations

### DPDT Cross-Wired for Three Switch Applications

In the OFF state, all three switches are open, the Alternating Relay is in the LOAD A position, and both loads are off. No action happens with the Alternating Relay or either load when the STOP Switch closes. When the LEAD Switch closes, Load #1 (M1) turns on. When the LAG Switch closes, Load #2 (M2) turns on. Both loads remain on as long as all three switches are closed.

When the LAG Switch opens, Load #2 (M2) remains on because the STOP Switch is still closed. When the LEAD Switch opens, Load #1 (M1) remains on because the STOP Switch is still closed. When the STOP Switch opens, both Load #1 (M1) and Load #2 (M2) are turned off simultaneously. The Alternating Relay toggles to the LOAD B position. The entire cycle is then repeated, but with Load #2 (M2) energized first followed by Load #1 (M1).





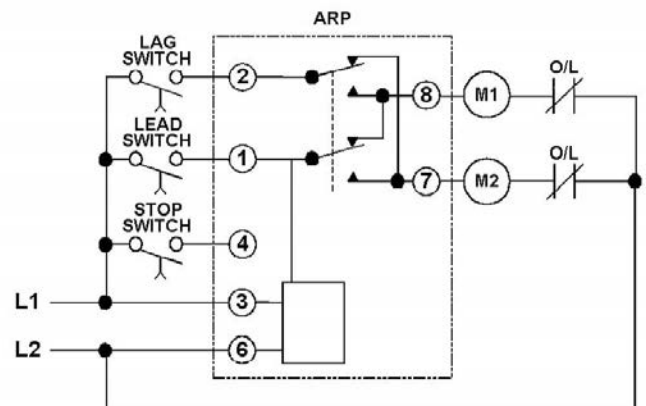
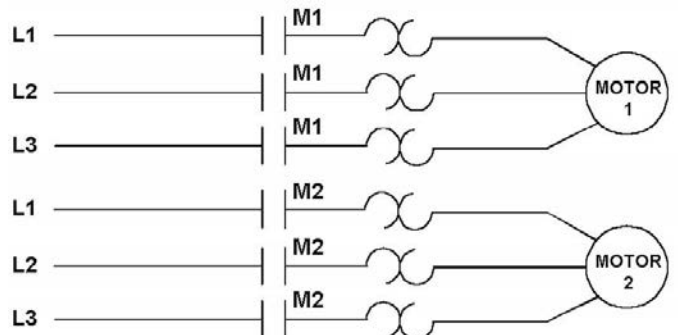

This type of operation is known as "Sequence On - Simultaneously Off (S.O.S.O.)"-the two loads are energized sequentially, but remain on together until the STOP switch is opened.

If both the STOP Switch and LEAD Switch fail to close and turn on the first load, both loads will be turned on simultaneously when the LAG Switch is closed.



# SOCKETS & ACCESSORIES

## Sockets

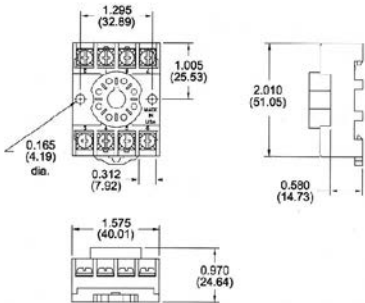
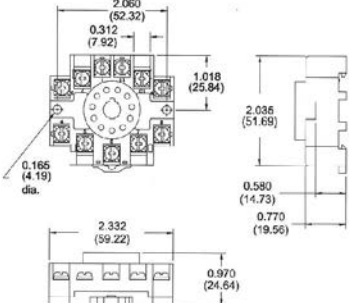
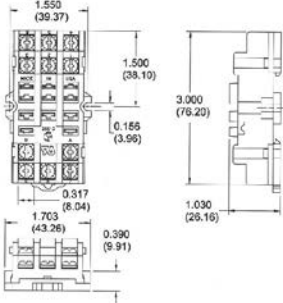
	Product Number 70169-D *	Product Number 70170-D	Product Number 70171-D
			
<b>Description</b>	8 Pin Octal	11 Pin Octal	11 Pin Spade (Blade)
<b>Ratings</b>	10A @ 600V *	10A @ 300V	10A @ 300V
<b>Mounting</b>	35MM DIN Rail / Direct Panel	35MM DIN Rail / Direct Panel	35MM DIN Rail / Direct Panel
<b>Wire/ Terminations</b>	1 or 2 #12-22 / Pressure Wire Clamps	1 or 2 #12-22 / Pressure Wire Clamps	1 or 2 #12-22 / Pressure Wire Clamps
<b>Approvals</b>			
<b>Dimensions</b>			

\* Plug-in Three-Phase Monitor Relays require a 600V-rated socket when used on system voltages greater than 300V.

## Other Accessories

Hold Down Spring  
Product Number 70166



DIN Mounting Track (1 Meter Section)  
Product Number 70100

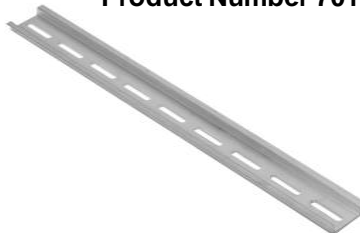



Alternating Relays



Time Delay Relays



Phase Monitor Relays



Voltage Monitor Relays



Current Monitor Relays

At Macromatic, we are committed to providing you with the right product, at the right time and at the right price.

### STANDARD PRODUCTS

- u Time Delay Relays
- u Alternating Relays
- u Phase Monitoring Relays
- u Voltage Monitoring Relays
- u Current Monitor Relays

### CUSTOM DESIGNS

- u Save money with a dedicated design to fit your application
- u Proprietary design protection offered
- u Agency approvals available

### TECHNICAL SUPPORT

- u Dedicated engineering team
- u One-on-one assistance
- u Application selection help
- u Technical troubleshooting aid
- u Toll free help line

### CUSTOMER SERVICE

- u Total Quality Program responsive to your needs
- u Short lead times on small quantity orders
- u Never a charge for expedited delivery
- u Local support through distributors & sales representatives
- u No minimum orders on standard products

For Details Contact us at  
800-238-7474 u 262-781-3366  
FAX 262-781-4433  
[www.macromatic.com](http://www.macromatic.com)  
[whats-up@macromatic.com](mailto:whats-up@macromatic.com)

# MACROMATIC



The Right Product  
The Right Time  
The Right Price



## Macromatic Controls

W134 N5345 Campbell Dr  
Menomonee Falls, WI 53051

800-238-7474- u 262-781-3366 u Fax 262-781-4433  
Web: [www.macromatic.com](http://www.macromatic.com) u Email: [whats-up@macromatic.com](mailto:whats-up@macromatic.com)