

## Rechargeable Nickel-Metal-Hydride Preliminary Button Cells 10 / V 500 HT SK S W

### System highlights of Ni-MH Button Cells – Powerful85 Family - from VARTA Microbattery:

- Excellent high-rate discharge characteristics (3 CA/5 CA). For short duration even higher currents can be drained
- No memory effect
- Long life – typical 500 full cycles
- Good overcharge capability
- Low self-discharge
- Flat and stable discharge voltage
- Slim design
- Wide temperature range
  - Storage: -40°C up to +65°C/+85°C
  - Discharge: -20°C up to +65°C/+85°C
  - Charge: 0°C up to +65°C/+85°C

### Key features:

- Good recovery characteristics after long storage period and deep discharge
- Sealed rechargeable Ni-MH Button Cells from VARTA Microbattery can be operated in any position
- The cells complete the manufacturing process in a charged state
- Because of time and temperature depending self-discharge, the state of charge upon receipt can not be precisely defined. Before use, therefore, sealed Ni-MH cells should be recharged.

### Quality – Made in Germany

- Manufactured on highly automated lines
- Direct replacement for Ni-Cd
- No memory effect
- 0% lead, 0% mercury, and 0 % cadmium
- UL recognition under file BBET2.MH13654
- ISO 9000 certified for design and manufacture of rechargeable mass type cells and batteries.

Conformity to requirements of ISO 9001

- VARTA Microbattery is a leader of Ni-MH Button Cell technology and received several ecological and industry awards
- are in line with ROHS (in accordance to EU directive 2002/95/EC). They do not contain the hazardous substances Hg, Cd, Pb, Cr<sup>6+</sup>, PBBs, PBDEs, as in ROHS, with Cd <100ppm and the others >1000ppm



### Electrical characteristics:

Nominal Voltage:	12.0 V
Typical Capacity:	500 mAh
Maximum Discharge current:	1.5A cont.
Short Circuit Protection:	PSR-25091 F

### Physical characteristics:

Width:	26 mm
Height:	40 mm
Length:	68 mm
Typical weight:	140 g
Connector:	Solder end
Wire length:	50 mm

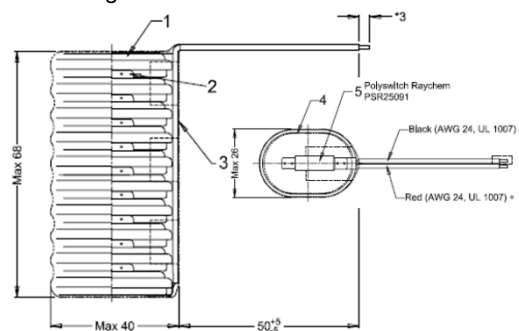

# Rechargeable Nickel-Metal-Hydride Button Cells

## 55750 310 000 10 / V 500 HT SK S W

### PROPER USE AND HANDLING

#### Charging

Recommended charging is continuous 50mA for 14-16h followed by Tricklecharge with 5mA. Higher charging currents shall be avoided to reduce possible risk by charging after deep discharge. Extended charging outside specified temperature ranges may have an adverse effect on cell life. Also permanent charging exceeding the limits of specified temperature ranges may reduce the battery life. The maximum life is achieved, when charging at an average temperature of +20 to +30°C.

#### Discharging

The specified temperature range is from -20 to +60°C resp. +85°C on discharge. Repeated discharge at the extreme temperatures may affect battery life. In all application do not deep-discharge (<0.6V/ cell) our Ni-MH cells and batteries.

#### Life Expectancy in Long-term use

Batteries are chemical products involving chemical reactions. Hence capacity and voltage will decrease over long time use as well as during long-term storage capacity and voltage will drop. Typically, a battery will last 5 years or 1000 IEC cycles, if used under recommended conditions and not overdischarged or overcharged. However, non-observance of recommended conditions concerning storage, charging, discharging, temperature and other factors during use can lead to shortened life expectancy of products and deterioration of performance.

### DESIGN INFORMATION

#### Discharge over temperature at 1CA

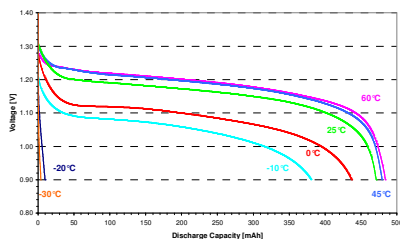

#### Discharge at various loads

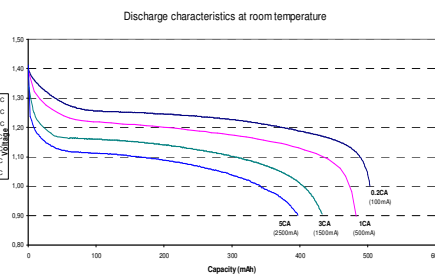

#### Self Discharge

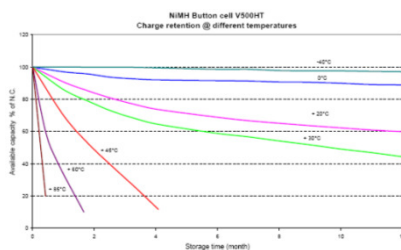

#### Overcharge

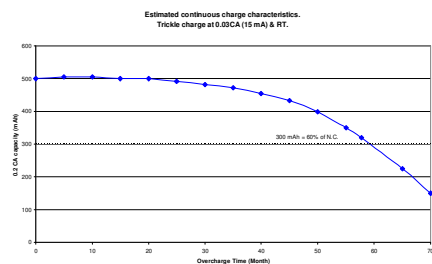

### SAFETY GUIDELINES

- Keep out the reach of children. If swallowed, contact a physician at once
- Do not incinerate or mutilate, may burst or release toxic materials
- Do not short circuit, may cause burns
- Do not deep-discharge into reserve
- Do not solder on the battery directly (use our tagged versions)
- Restrict charging current and time to the recommended value
- Observe charging temperature: 0 to +65°C/ +85°C
- Battery compartment should provide sufficient space for battery to expand in a case of abuse
- Either battery compartment or battery connector should have a design that makes it impossible to place the battery in reverse polarity
- Equipment intended for use by children should have tamper-proof battery compartment
- Battery of different electrochemical system, grades, or brands should not be mixed
- Battery disposal method should be in accordance with local and state regulations
- Please refer to our Material Safety Datasheets as supporting documents

VARTA Microbattery GmbH  
Daimlerstraße 1  
73479 Ellwangen/Germany  
Tel +49 79 61 921-0

[www.varta-microbattery.com](http://www.varta-microbattery.com)