

DevKit1207 Evaluation Kit

- *120MHz STM32F207IGT6 ARM Cortex-M3 32-bit Flash Microcontroller*
- *CPU Internal 1MBytes of Flash and 128 (system) +4 (backup) KBytes of SRAM*
- *1 USB2.0 OTG Full-speed Port and 1 USB2.0 OTG High-speed Port*
- *3.5-inch TFT LCD and 4-wire Resistive Touch Screen*
- *10/100 Ethernet with IEEE 1588v2, CAN2.0B, IrDA, TF, Audio, JTAG...*
- *G-sensor 3-Axis Acceleration Sensor*
- *Optional 1.3 megapixel Digital Camera Module*
- *Supports for uC/OS-II and FreeRTOS Real-time Operating Systems*

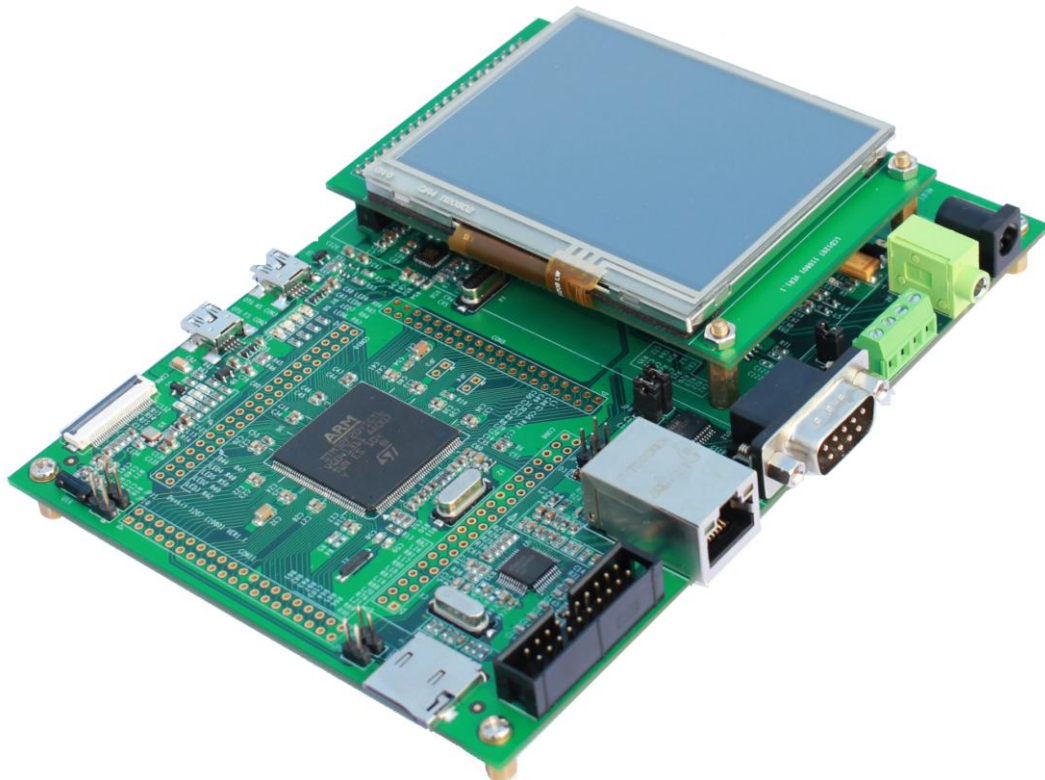

Figure 1-1 DevKit1207 Evaluation Board with 3.5" LCD and Touch Screen

Overview

The STMicroelectronics' STM32F207IGT6 flash microcontroller is among STM32F207xx family, which is based on the high-performance ARM Cortex-M3 32-bit RISC core operating at a frequency of up to 120MHz, with high-speed embedded memories (1Mbytes of flash memory and 128Kbytes of system SRAM), 4Kbytes of backup SRAM, and powerful peripheral functions, including digital camera module interface, High-speed USB OTG, Full-speed USB OTG, Ethernet MAC, CAN2.0B, multiple timers, ADCs and DACs, I2C, I2S, SPI, UARTs/USARTs, SDIO, LCD interface, RTC and programmable IOs.

Embest DevKit1207 Evaluation Kit is a complete development platform for STM32F207IGT6 devices which enables engineers to easily and rapidly evaluate, prototype and test designs built around the STMicroelectronics STM32F207xx series microcontrollers. The DevKit1207 board has on-board 2Kbits EEPROM and exposed a full range of hardware peripherals to support HS/FS USB OTG, Ethernet, CAN, Serial port, IrDA, TF card, LCD, Touch screen, Audio, G-sensor, RTC, JTAG, etc. The kit is provided with an industrial-level 3.5 inch LCD with resistive

touch screen. A digital camera module CAM1207 is also offered as an option to customers.

Embest has ported uC/OS-II and FreeRTOS real-time operating systems on this board and the software also features the GUI support on uC/OS-II and LwIP_v1.3.2 protocol support on FreeRTOS. Embest provides the uC/OS-II BSP, FreeRTOS source tree and plenty of software examples, board schematic and user manual to help customer better understanding this board and develop your own applications.

Hardware Features

Processor

- STMicroelectronics STM32F207IGT6 Flash Microcontroller
- ARM 32-bit Cortex-M3 CPU with ART accelerator, frequency up to 120MHz
- Onchip 1Mbytes of Flash memory and 128+4Kbytes of SRAM
- Flexible static memory controller that supports Compact Flash, SRAM, PSRAM, Nor and Nand memories
- LCD parallel interface, 8080/6800 modes
- USB 2.0 HS/FS Device/Host/OTG
- 10/100 Ethernet MAC, supports IEEE 1588v2 hardware, MII/RMII
- 2 CAN 2.0B interfaces, 4 USARTs and 2 UARTs, 2 with muxed I2S, 3 SPI (30Mbit/s)
- 8- to 14-bit parallel camera interface (up to 48Mbytes/s)
- 1-/4-/8-bit SD/MMC/SDIO interface, supports up to 32Gbytes storage
- Up to 140 I/O ports up to 60MHz
- Up to 17 timers (two 32-bit timers), up to 120MHz
- 3 x 12-bit A/D converters, 2 x 12-bit D/A converters
- Analog true random number generator
- Low power, supports Sleep, Stop and Standby modes
- Supports booting from Flash, System memory or SRAM
- Supports ISP and IAP programming

External Memory

- Onboard I2C compatible serial interface 2Kbits EEPROM
- Micro SD card slot

Audio interfaces

- 1-channel stereo headphone output jack
- 1-channel speaker output jack
- 1-channel audio DAC output jack

LCD/Touch Screen

- 3.5 inch TFT color LCD (240 x 320-pixel RGB resolution, 262000 colors, 16-bit 8080 parallel interface, brightness control via PWM)
- 4-wire resistive touch screen

Data Transfer Interfaces

- 1-channel 5-wire RS232 Serial Port
- 1 x USB2.0 OTG/Device/Host, High-speed, 480Mbps
- 1 x USB2.0 OTG/Device/Host, Full-speed, 12Mbps
- 10/100 Ethernet with IEEE 1588v2 (RJ45 connector)
- 1 x CAN2.0B interface
- IrDA transceiver

Input Interface and Other Facilities

- 1 x Potentiometer (A/D converter)
- 2 x USER buttons
- 1 x RESET button
- 1 x WAKEUP button
- 20-pin standard JTAG interface
- RTC battery socket (User needs to prepare battery, CR1220 model is recommended)
- 1 x LED for Power indicator
- 2 x LEDs for USB OTG FS indicators
- 2 x LEDs for USB OTG HS indicators
- 4 x User LEDs
- 140 GPIO pins are all brought out

Mechanical Parameters

- Dimensions: 160 mm x 115 mm
- Input Voltage: +5V
- Power consumption: 0.4A@5V
- Working Temp.: -10 °C ~ 70 °C
- Humidity Range: 20% ~ 90%

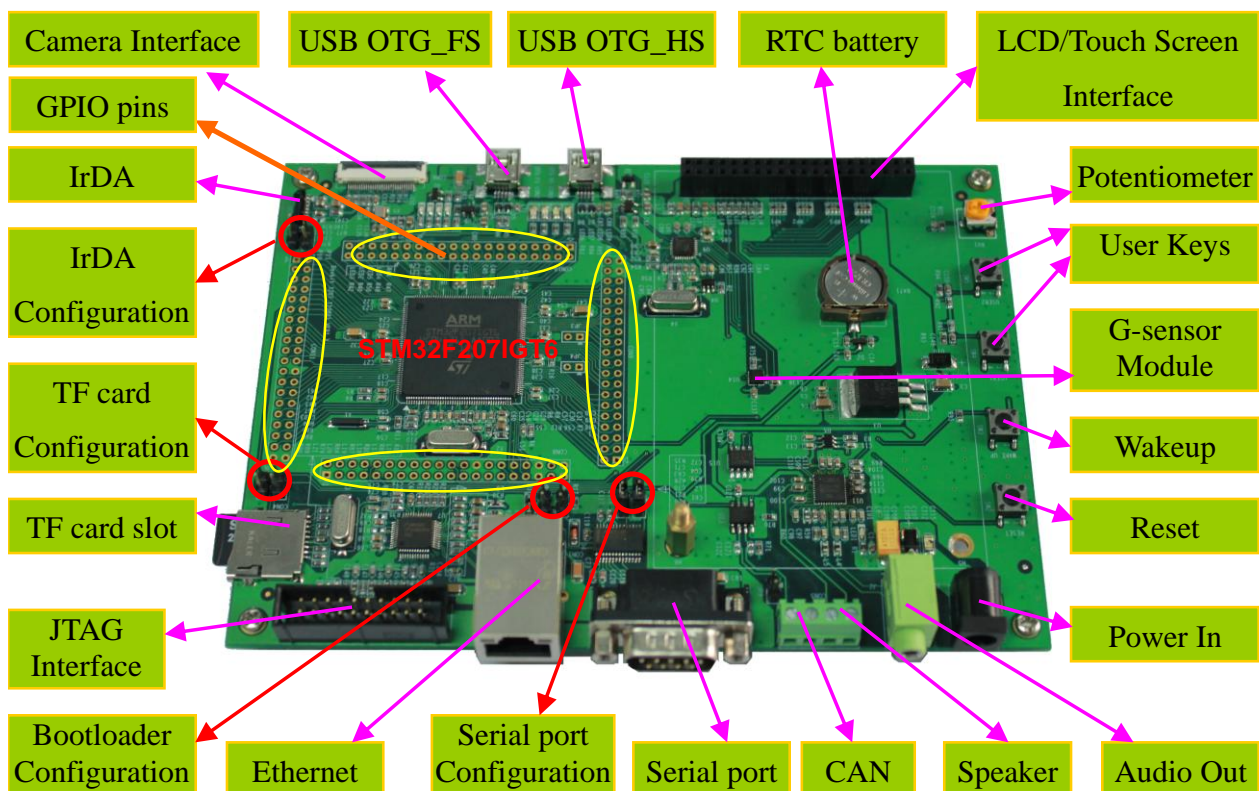

Note: RTC battery is not provided in default deliveries, user needs to prepare it yourself, Type model CR1220 is recommended. Some functions need to use Jumpers to configure before using.

Figure 1-2 DevKit1207 Evaluation Board

Optional Digital Camera Module CAM1207

The CAM1207 Digital Camera Module is designed specially for using on Embest **DevKit1207** products connecting via 30-pin FPC connector. It uses a CMOS image sensor which is a 1.3 megapixel Digital Camera.

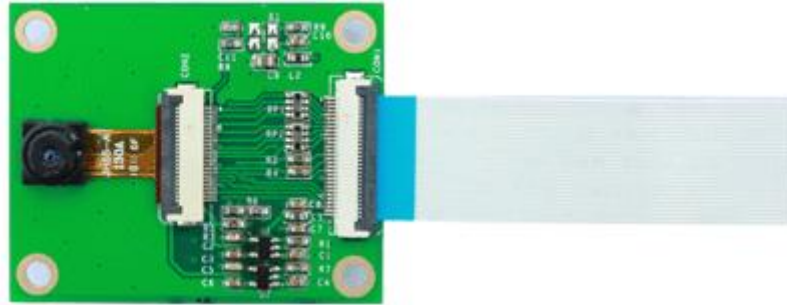

CAM1207 Digital Camera Module



CAM1207 connects to DevKit1207 board

Dimension	47.8mm * 37.6mm * 6mm
Signal system	CMOS 1.3 megapixel
Resolution	up to 1280 * 1024
Frame rate	15 fps for SXGA
	30 fps for VGA, CIF
Interface	30-pin FPC connector
Power supply	From board
Working Temp.	-10 ~ +70 °C
Board Support	DevKit1207
Functions	Supports photo taking Supports photo saving

Function Block Diagram

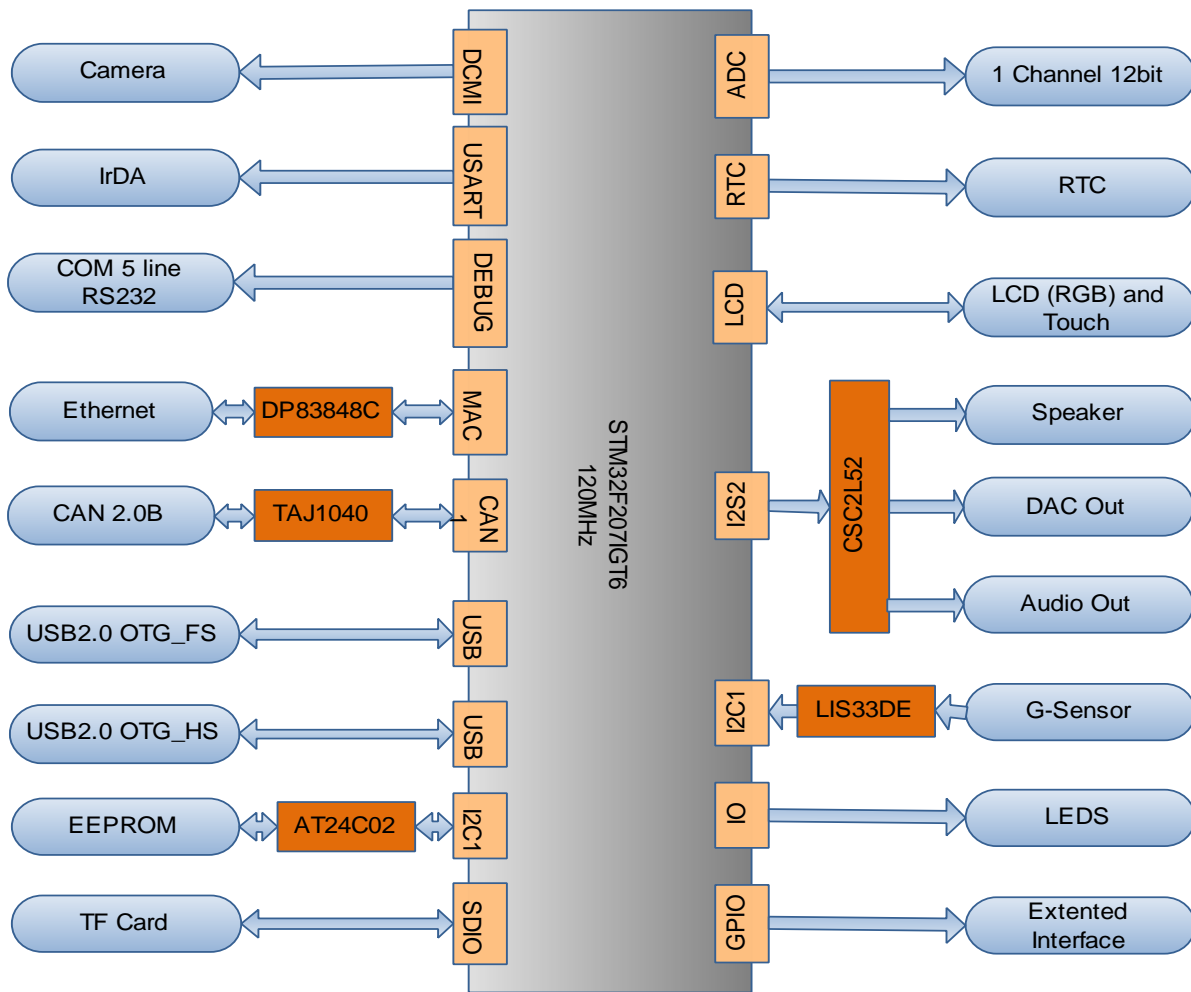

Figure 1-3 DevKit1207 Function Block Diagram

Software

Features

The DevKit1207 Evaluation Kit software mainly features as below:

- Supports for uC/OS-II_v2.86 and FreeRTOS_v6.1.0 real-time operating systems
- Supports UCGUI_v3.90a
- Supports FatFs_vR0.08a file system
- Supports LWIP_v1.3.2 protocol stack
- Provided with plenty of source code

Boot Modes

The DevKit1207 Evaluation Board is able to boot from CPU internal system memory or embedded SRAM, user needs to configure the boot pins to select the mode. The boot loader is located in system memory. It is used to reprogram the Flash memory by using Serial port or USB OTG FS in Device mode through DFU (device firmware upgrade).

Drivers and Software examples

Embest has provided complete drivers and software examples for this kit. User can demonstrate and test each software example and observe the result from LCD which would be easy to understand.

The software examples mainly include following parts:

- Examples for Basic peripherals drivers (see Table 1-1 below)

Table 1-1

ADC	ADC3_DMA	Transfer ADC3 converted data to to the memory using DMA
	DualADC_Interleaved_DMAMode3	Cross access dual-channel ADC converted data using DMA mode 3
	DualADC_RegulSimu_DMAMode1	Synchronization access dual-channel ADC converted data using DMA mode 1
	TripleADC_Interleaved_DMAMode2	Cross access three-channel ADC converted data using DMA mode 2
CAN	LoopBack	CAN loopback testing example
	Networking	CAN communication testing example
CRC	CRC_Example	CRC verify testing example
DAC	DAC_SignalsGeneration	DAC signal generator (can get various wave signals) testing example
DMA	FLASH_RAM	Transfer data from Flash to RAM using DMA
EXTI	EXTI_Example	Configure external interrupt of EXTI
FLASH	Program	Programming Flash, block erase, read and write

	Write_Protection	Write protection on Flash
GPIO	IOToggle	Configure voltage of specified pins via GPIOs
	JTAG_Remap	Remap JTAG pins as general IOs
I2C	EEPROM	Read and write on EEPROM using I2C
	GSensor-LIS33DE	3-Axis Acceleration Sensor testing example
I2S	Audio	Play audio testing example through I2S
IWDG	IWDG_Example	Single watchdog reset function example
LCD-Touch	STMPE811QTR	LCD and Touch screen application testing example
Lib-DEBUG	Lib_DEBUG_Example	DEBUG testing example
NVIC	DMA_WFIMode	Wakeup system from WFI mode using DMA data stream interrupt
	IRQ_Priority	Set interrupt using interrupt priority
	VectorTable_Relocation	Relocate interrupt using interrupt table
PWR	BOR	Power-Off Reset testing example
	CurrentConsumption	Current testing example
	PVD	Programmable voltage detection testing example
	STANDBY	Standby mode testing example
	STOP	Stop mode testing example
RCC	RCC_Example	Configure different system clock frequency via RCC
RNG	RNG_MultiRNG	Multi-channel random number generator testing example
RTC	BKP_Domain	Implement using perpetual calender through BKP_Domain
	HW_Calendar	Implement using RTC Alarm through RTC controller
	TimeStamp	Implement time-stamping function through RTC controller
SDIO	uSDCard	Read and write SD card using FatFs_vR0.08a
SysTick	SysTick_Example	Implement delay through tick interrupt, light up LED with flick
TIM	6Steps	6-phase PWM output testing example
	InputCapture	TIM input capture mode testing example
	OActive	TIM output active mode testing example

	OCInactive	TIM output inactive mode testing example
	OCToggle	TIM output trigger mode testing example
	OnePulse	TIM single pulse mode testing example
	Parallel_Synchro	Several TIM parallel and synchronization testing example
	PWM_Input	PWM input mode testing example
	PWM_Output	PWM output mode testing example
	TIM1_Synchro	TIM1, 3 and 4 parallel and synchronization testing example
	TIM9_OCToggle	TIM9 output trigger mode testing example
	TIM10_PWMOutput	Timer 10 PWM output testing example
	TimeBase	Timer basic function testing example
USART	USART_IRDA	IrDA transmitting and receiving testing example
	USART_Printf	Hyper-terminal input and output testing example
WWDG	WWDG_Example	Watchdog reset testing example

- Example for IrDA driver
- Example for I2S Audio driver
- Application example for G-sensor
- Application example for SD card supporting FatFs_vR0.08a file system
- Application example for USB Host/Device/OTG (see Table 1-2 below)

Table 1-2

USB Device application examples	
AUDIO	Use board as audio device, similar to USB acoustics, user can play music on PC and output sound through board
DFU	Use board as DFU device, user can use it for system firmware updating.
DualCore	Dual-USB channel testing example. Use HS-USB as MSC device and FS-USB as HID device.
HID	Use board as HID (Human Interaction Device) to implement USB mouse operation.

MSC	Use board as MSC (Mass Storage Device) to implement data exchange between USB Host and board.
VCP	Use board as VCP (Virtual COM Port), user can regard board as a USB-to-COM module
USB OTG application examples	
DRD	DevKit1207 board can be used as either USB Host or USB Device
USB Host application examples	
DualCore	Dual-USB channel testing example, use HS-USB as MSC (Mass Storage Device) host and FS-USB as HID (Human Interaction Device) host.
HID	Use board as HID (Human Interaction Device) host and can recognize USB mouse and USB keyboard.
MSC	Use board as MSC (Mass Storage Device) and can recognize U disk and other mobile storage devices.

- Application example for Ethernet on FreeRTOS/Non-OS/LWIP v1.3.2 protocol stack (see Table 1-3 below)

Table 1-3

Application example for Ethernet on FreeRTOS and LWIP v1.3.2 protocol stack	
httpserver_netconn	Webserver application example based on netconn
httpserver_socket	Webserver application example based on socket
udptcp_echo_server_netconn	TCP/UDP Echo application example based on netconn 的 TCP/UDP
Application example for Ethernet on Non-OS and LWIP v1.3.2 protocol stack	
httpserver	Webserver application example
tcp_echo_client	Simple Echo application example of Tcp client
tcp_echo_server	Simple Echo application example of Tcp server
tftpserver	Tftpserver application example
udp_echo_client	Simple Echo application example of dup client
udp_echo_server	Simple Echo application example of server

- Application example for OS porting on UCOSII_v2.86 and UCGUI_v3.90a

Function Demonstrations

GUI3.90A Function Demonstration (see Figure 1-1)

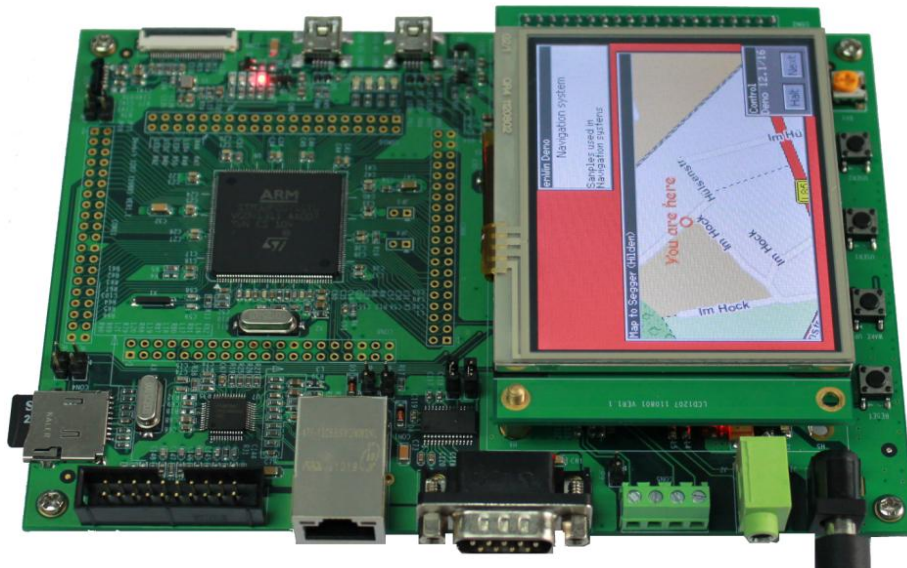

Figure 1-1

2-channel USB Host Function Demonstration (see Figure 1-2)

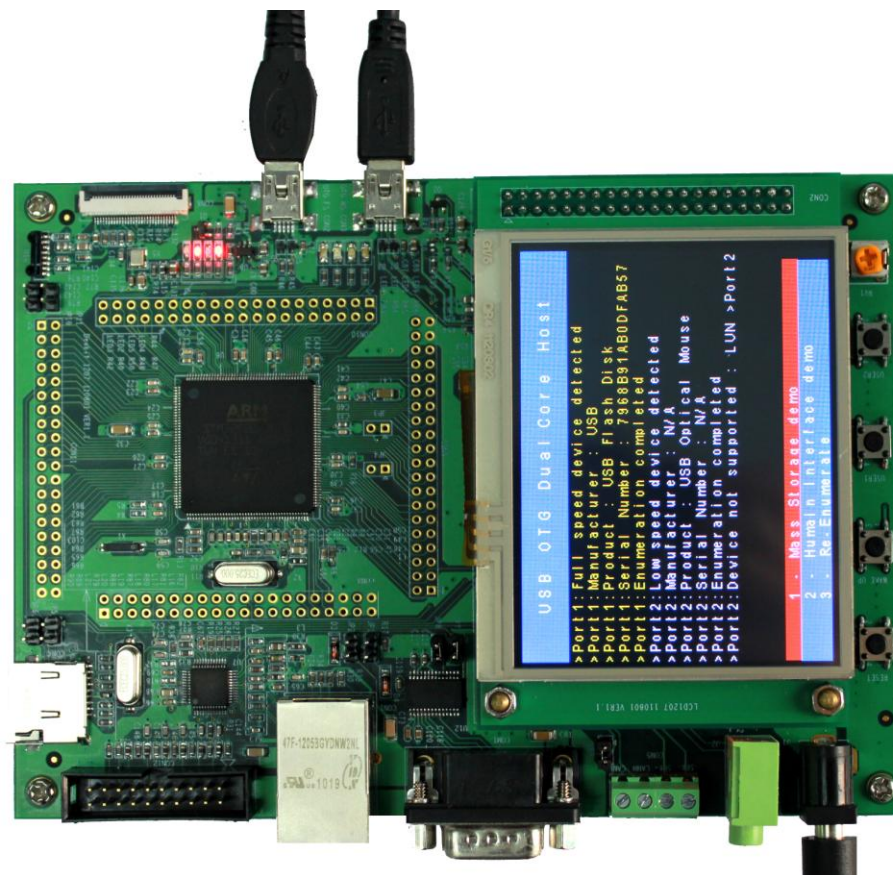

Figure 1-2

Httpserver Network Function Demonstration

1) Input <http://192.168.0.163> in browser and you can visit the webpage on DevKit1207.

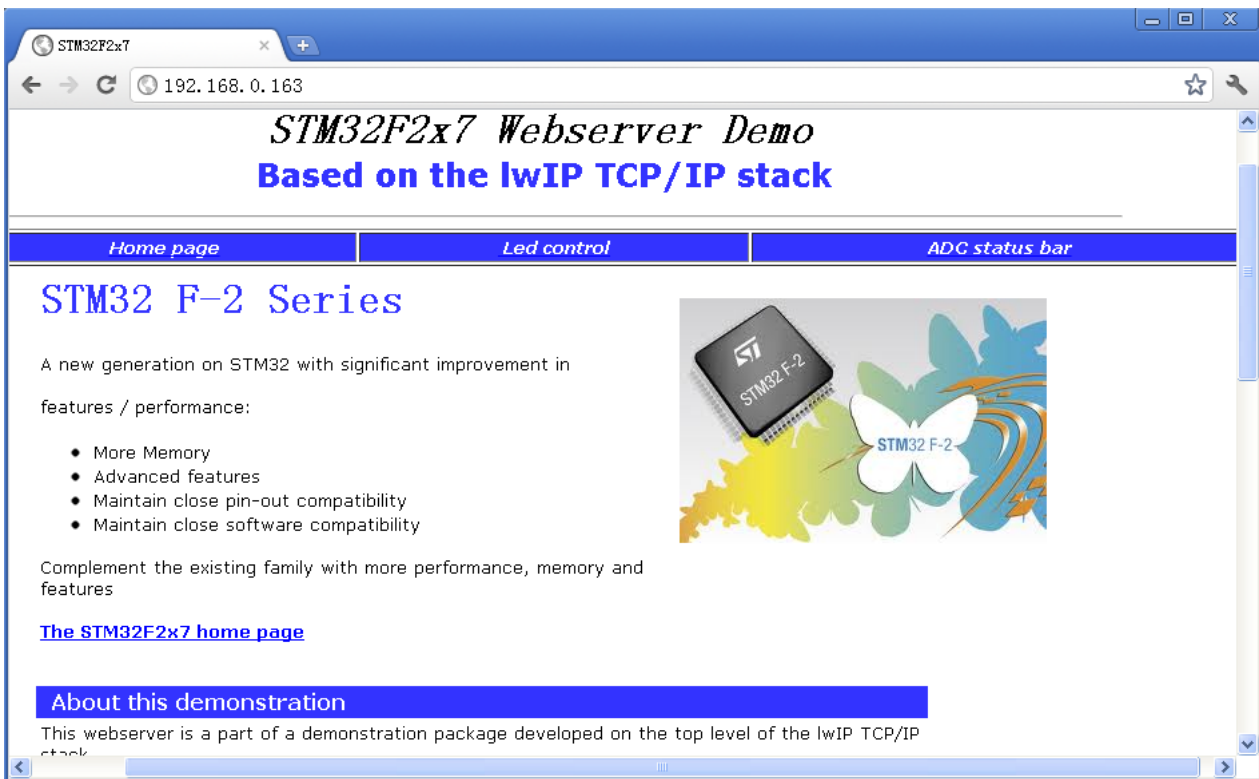

Figure 1-3

2) Click “LED control” to get into LED control interface, select or cancel LED1, LED2, LED3, LED4 and press “Send”, the LEDs on board will work relatively.



Figure 1-4

3) Click “ADCstatus bar” to get the voltage of potentiometer on board.

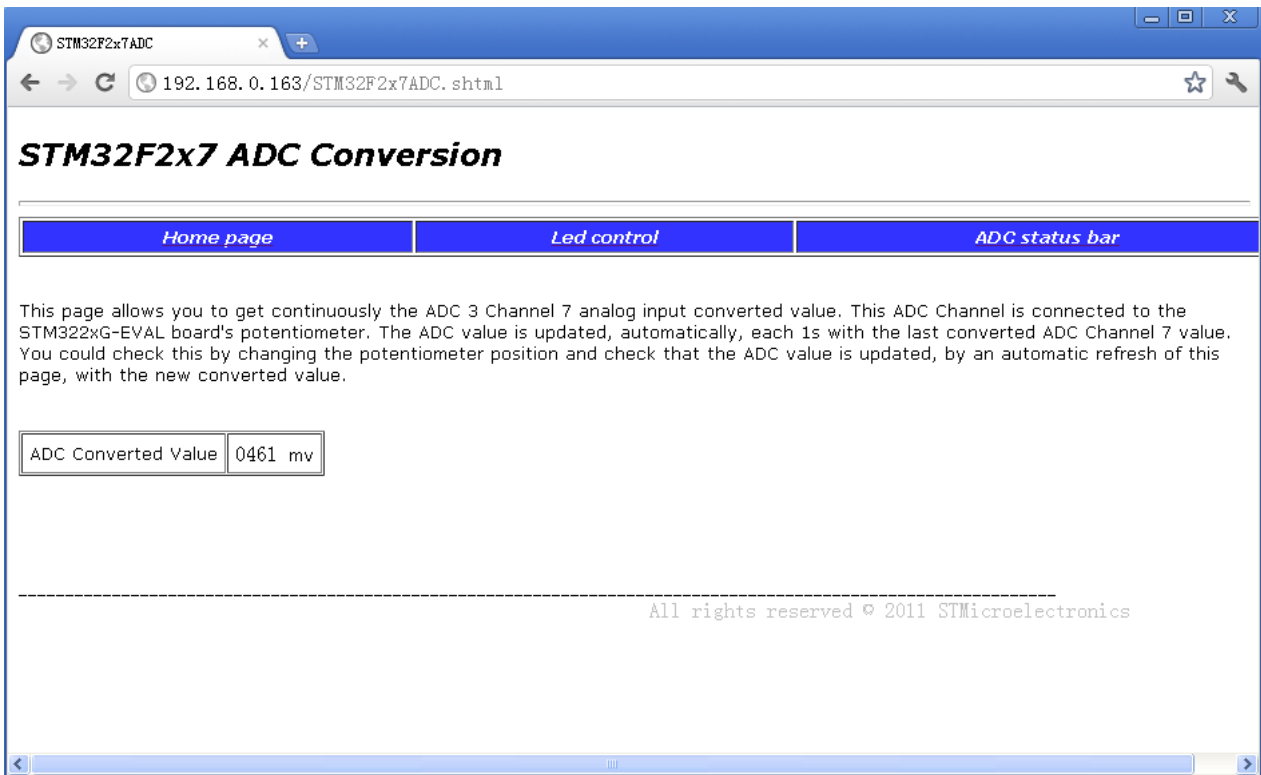
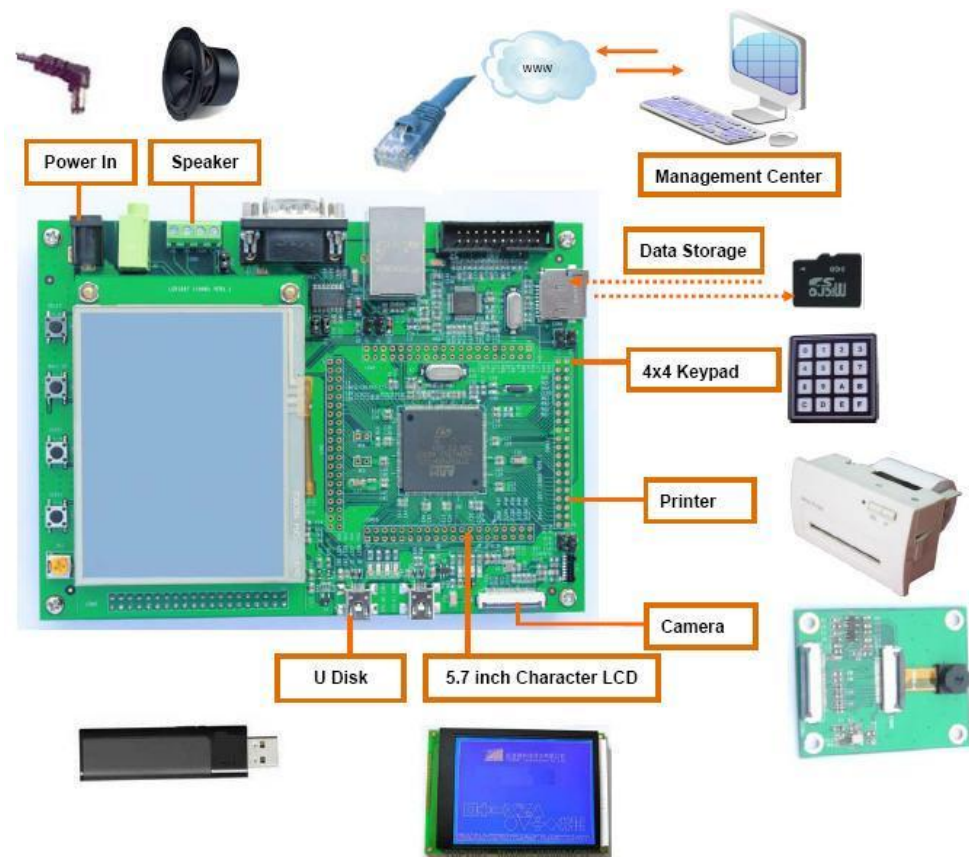

Figure 1-5

Application cases (Remote Control System Solution)



Order Information

Order No.	T6010169
Item	DevKit1207 Evaluation Kit
Deliveries	<ul style="list-style-type: none">• One DevKit1207 Evaluation board• One 3.5 inch LCD with Touch screen• One 5V Power adapter• One cross serial cable (DB9 to DB9)• One cross net cable• One USB cable (Type A Male to Type Mini-B Male)• One USB cable (Type A Female to Type Mini-A Male)• One Product CD (including user manual, schematic in PDF format, datasheet, uC/OS-II BSP, FreeRTOS source tree, software examples)
Option	<ul style="list-style-type: none">• CAM1207 Digital Camera Module
Price	Please contact us.

More information about this product can be found at:

<http://www.embedinfo.com/english/Product/devkit1207.asp>

<http://www.armkits.com/Product/devkit1207.asp>

**Embest Technology Co., LTD.**

Room 509, Luohu Science&Technology Building,
#85 Taining Rd., Shenzhen, Guangdong, China 518020

Tel: +86-755-25635656/25636285

Fax: +86-755-25616057

Email: market@embedinfo.com

<http://www.embedinfo.com/english> <http://www.armkits.com>