

Axial Fan

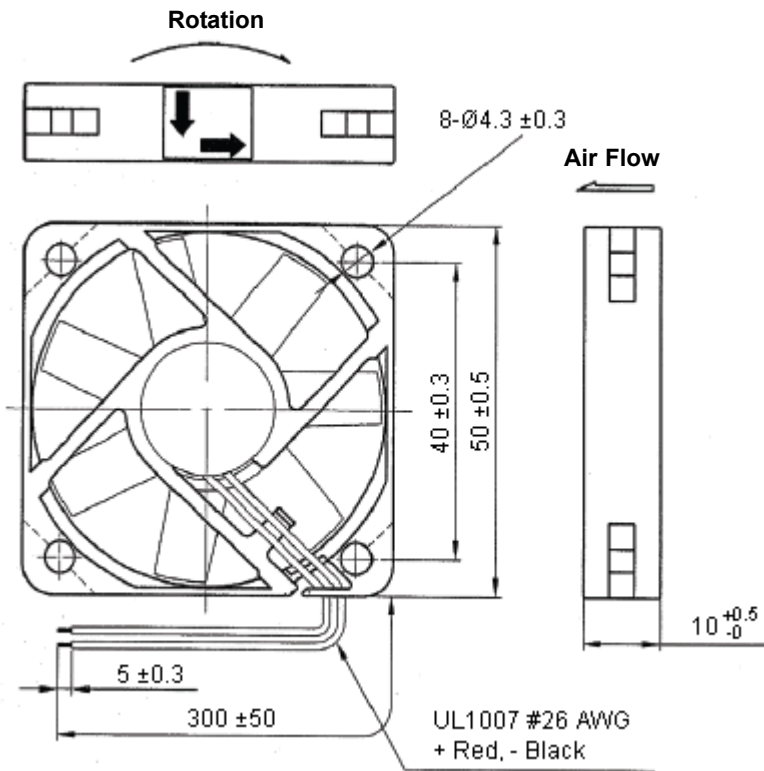

UL File Number : E175395

Dimensions : Millimetres

Specifications:

Mechanical Characteristic

Motor Design	: 2 phases, 4-poles brushless dc motor
Bearing System	: Lubricated sleeve bearing system
Speed	: High
Dimensions	: See diagram
Material of Frame	: Thermoplastic PBT of UL 94V-0
Material of Fan Blade	: Thermoplastic PBT of UL 94V-0
Direction of Rotation	: Counter - clockwise viewed from front of fan blade
Mounting Holes	: Diameter 4.3 mm in 8 holes
Weight	: 17.5 g

Electrical Characteristic

Rated Voltage	: 12 V dc
Rated Current	: 110 mA / maximum 127 mA
Rated Power Consumption	: 1.32 watts / maximum 1.53 watts
Operating Voltage Range	: 4.5 to 13.8 V dc
Starting Voltage	: 4.5 V dc (25°C power on / off)
Operating Temperature Range	: -10°C to +70°C
Storage Temperature Range	: -40°C to +70°C

Performance Characteristic

Rated Speed	: 5,000 RPM \pm 15% at rated voltage
Air Flow	: 12.5 CFM
Static Pressure	: 0.13 inch-H ₂ O
Acoustic Noise	: 29 dB (A)
Air Flow vs Pressure	: See performance curve
Insulation Class	: UL class A
Insulation Resistance Plastic Housing	: 10 M Ω at 500 V dc between internal stator and lead wire (+)
Dielectric Strength	: Applied 500 V ac for one minute or 600 V ac for 2 seconds between housing and lead wire (+)
Life Expectancy	: 35,000 hours at 40°C, 65% humidity, 90% CL
Protection	: <input type="checkbox"/> Automatic Restart
	Note : In a situation where the fan is locked by an external force while the electricity is on, an increase in coil temperature will be prevented by temporarily turning off the electrical power to the motor. The fan will automatically restart when the locked rotor condition is released
Protection	: <input type="checkbox"/> Polarity Protection

Performance Curve

Static Pressure

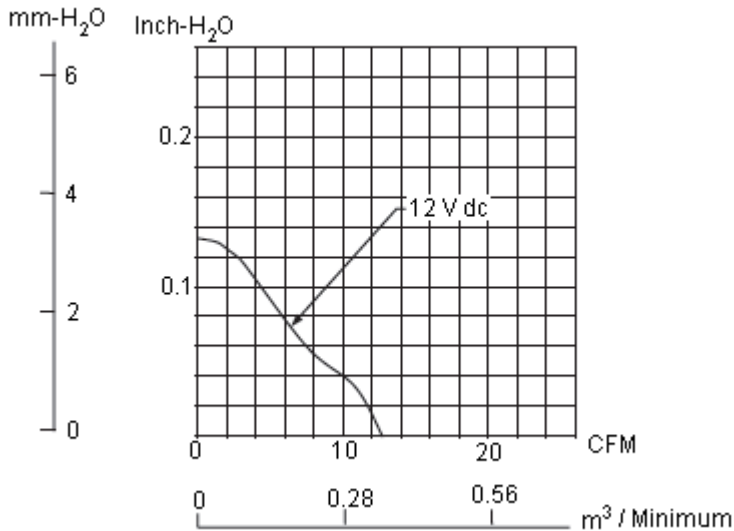

Part Number Table

Description	Part Number
Axial Fan	MC36265

Important Notice : This data sheet and its contents (the "Information") belong to the members of the Premier Farnell group of companies (the "Group") or are licensed to it. No licence is granted for the use of it other than for information purposes in connection with the products to which it relates. No licence of any intellectual property rights is granted. The Information is subject to change without notice and replaces all data sheets previously supplied. The Information supplied is believed to be accurate but the Group assumes no responsibility for its accuracy or completeness, any error in or omission from it or for any use made of it. Users of this data sheet should check for themselves the Information and the suitability of the products for their purpose and not make any assumptions based on information included or omitted. Liability for loss or damage resulting from any reliance on the Information or use of it (including liability resulting from negligence or where the Group was aware of the possibility of such loss or damage arising) is excluded. This will not operate to limit or restrict the Group's liability for death or personal injury resulting from its negligence. Multicomp is the registered trademark of the Group. © Premier Farnell plc 2012.