

Relay coupler

Relay coupler

Overview	K.2 - K.7
PLUGSERIES	K.8 - K.15
PLUGINDUSTRIE	K.16 - K.19
MICROSERIES	K.20 - K.23
WAVESERIES	K.24 - K.29
RS-SERIES	K.30 - K.39
MCZ-SERIES	K.40 - K.41
DK-SERIES	K.42 - K.45
EG-SERIES	K.46 - K.47

Optocoupler

Optocoupler

Overview	K.48 - K.53
PLUGSERIES	K.54 - K.59
MICROSERIES	K.60 - K.63
WAVESERIES	K.64 - K.71
MCZ-SERIES	K.72 - K.75
DK-SERIES	K.76 - K.81
EG-SERIES	K.82 - K.85

Time relays

Time relays

BT-SERIES	K.86 - K.91
DK-SERIES	K.92 - K.94
MCZ-SERIES	K.95

Function modules

Function modules

Overview	K.96 - K.97
Alarm and command modules	K.98
Rectifier modules	K.99
Diode array	K.100
equipping modules	K.101
Logic modules	K.102 - K.103

Relay coupler – overview

Weidmüller **relay modules** have a universal foot structure so that they can be fitted in rows on the TS 32, TS 35 x 7.5 and TX 35 x 15 mounting rails acc. to EN 50 035 and EN 50 022.

In the coil circuit of the relay modules, an LED status indication shows the switching state of the relay.

Our highlight:

MICROSERIES

Coupler modules in terminal format

The slot-in width of 6.1 mm allows for space-saving installation of the **MICROSERIES** relays in a wide range of applications. The **MICROSERIES** is particularly suitable for the modification and extension of installations and machinery. In such cases, it helps to make optimum use of the limited space available in switchgear cabinets.

Marking

The tab surfaces enable equipment to be clearly marked using a WS marker.



Holding and ejecting mechanism

The innovative holding and eject mechanism clips the assembled module securely onto the basic terminal. With the reliable eject function, the coupler can be removed quickly and simply from the base.

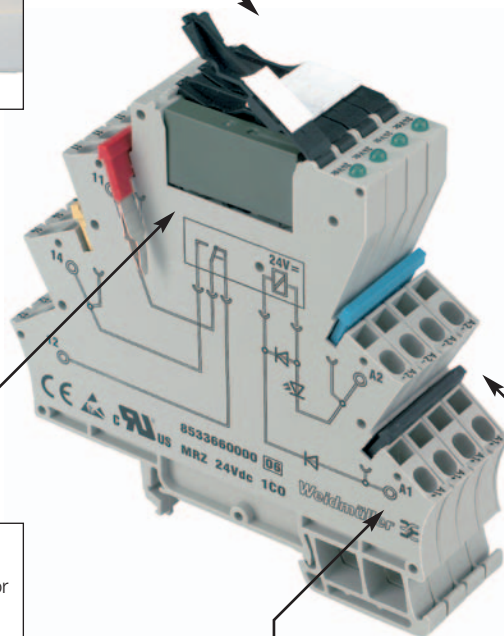

Relay and optocoupler module

Plug-in relay and optocoupler modules allow for individual adjustment of the module functions. Relay couplers are available with different power outputs with either AgSnO and gold contacts.

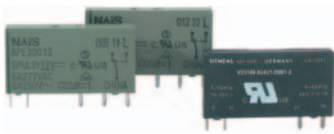

Connection technology

Most of our relay couplers are available with screw or tension clamp connections.



Pluggable cross-connectors

The ZQV 4N plug-in cross-connectors are available in various colours and with different numbers of poles. They allow for reliable and distinct cross-connections between the four input and output potentials.

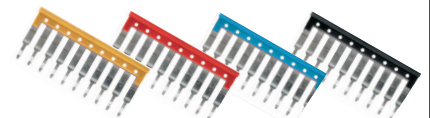

Relay coupler – overview

Contact types

Several contact types and combinations are available ex stock:

- 1 NCC (EGR EG7, RS 30)
- 1 NOC (EGR RG7, DKR, RS 30)
- 1 NCC and 1 NOC (WRS)
- 2 NOCs (WRS)
- 3 NOCs (WRS)
- 1 change-over contact (EGR/RST EG7, WRS, DKR, PRS/PRZ MCZ R, RS 30, RS 31)
- 2 change-over contacts (WRS, RS 32, PRS/PRZ)
- 4/8/16 change-over contacts (RSM)

Contact material

The relay modules are suitable for universal use, with the choice of contact material the crucial criterion. The contact is used for safe transmission of control signals and also for switching power contactors.

Gold-plated or gold-flashed AgNi contacts are used for most applications. Hard gold plated contacts with gold plating exceeding 2 μm in thickness allow even extremely small capacities (up to 40 μW) to be switched. AgSnO₂ or AgCdO contacts are used for switching higher capacities (RS 31).

Protective circuits for the contacts

The switching of inductive or capacitive loads produces switching sparks which can influence the electrical service life of the relays.

The following protective circuits for the contacts reduce contact wear:

Diode

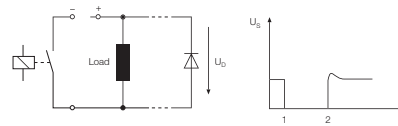

- Advantage: Can be used for all capacities, low overvoltage, minimum space required, low price
- Disadvantage: Very large release delay

Diode and Z-diode

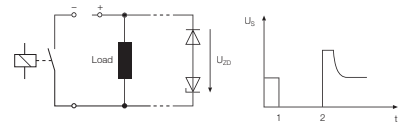

- Advantage: Low overvoltage (defined by Z-diode), low release delay
- Disadvantage: Cannot be used for large capacities

RC combination

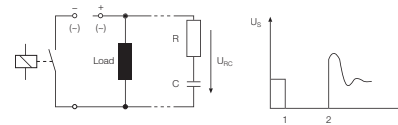

- Advantage: Low overvoltage, low release delay
- Disadvantage: High current load on the contacts when switching on; more complicated and expensive at greater capacities

Varistor

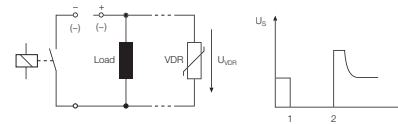

- Advantage: Low release delay, low price
- Disadvantage: Cannot be used for all operating voltages and capacities

- U_S Voltage progression
- 1 Closing
- 2 Opening

Switching small and large capacities

For automation technology, the EGR EG7 relay coupler is ideal for switching extremely small capacities (up to 40 μW) under ohmic load. The signals are reliably transmitted to the controllers. The switching of large capacities for energy and supply technology is achieved by the RS31 relay coupler, with a guaranteed switching capacity of 3.5 kVA under ohmic load.

Switching times of the relay modules

Typical pick-up delay < 10 ms
Typical release delay < 12 ms

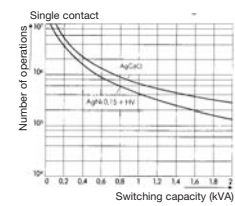

Contact service life under ohmic load

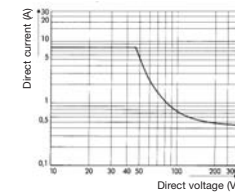

DC load-limit curve under ohmic load

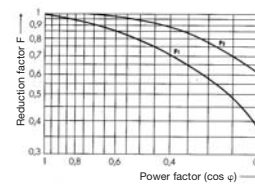

Reduction factor under inductive load
cos φ < 1

No. of cycles_{eff.} = No. of cycles at (cos φ = 1) × red. factor F

Relay coupler – overview

Relay coupler with plugged relay

Relay couplers with plugged relay have only limited suitability for use in a highly oscillating environment. Preference should be given to relay couplers with soldered relays.

Derating curve

The transition resistance of the relay contacts is a key factor contributing to temperature increase inside the relay modules. This relationship is illustrated by a derating curve, defined as the function of the permissible current plotted against the ambient temperature.

The permissible current (Curve a) is determined for the following operating conditions:

- Continuous operation
- Rated input voltage + 10 percent
- Several relay modules working under load, mounted horizontally in rows on mounting rail, without any spacing

If the modules are mounted with a spacing > 20 mm, this results in a higher current load (Curve b). Curve b also shows the maximum values for switching or short-time operation in horizontally mounted state.

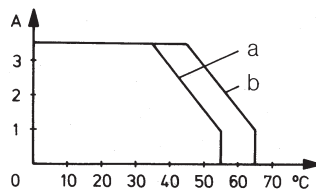

Notes on application

The key data of the triggering device must be precisely adhered to when using UC versions in DC circuits. As a result of their pre-circuitry, UC versions take up larger quantities of current. The internal current limit of standard initiators can mean that the triggered relay couplers are not switched through.

Relay couplers with 24 V AC/DC input are not suitable for triggering by initiators; purely DC versions are recommended for these applications.

RC combination

Long leads are subject to greater electrical and electromechanical influences. This may cause malfunctions and even failure of the relay modules. One possible remedy is to insert an RC combination to filter out the interference. RC combinations are available for all common relay couplers, as pluggable (PLUGSERIES) solutions or WDU 12C and DKU 12C terminals.

Relay coupler – overview

Definition of the technical data

Protective separation

All equipment guaranteeing “protective separation” is to be designed so that any faults (e.g. mechanical faults) cannot affect the insulation. If a mechanical fault occurs in a relay (bent soldering post, broken winding wire or broken spring), “protective separation” must also be guaranteed in such cases.

Relays are specified and tested to IEC 255 and VDE 0435. Neither standard makes reference to EN 50 178 (electronic equipment for use in high current installations), nor do they contain a definition of “protective separation”. Furthermore, other measuring conditions are used as the basis for the test voltages stated for the relays. So the test voltages cannot be transferred to EN 50 178 or DIN VDE 0106 part 101. In view of the fact that users are increasingly turning to equipment which guarantees “protective separation”, many relay manufacturers now refer to DIN VDE 0106 and test their products accordingly. The stated values then correspond with “protective separation”.

Standards

The following standards are fulfilled:

- EN 50 178:
Electronic equipment for use in high current installations
- DIN VDE 01206 part 101:
Protection from dangerous body currents, basic requirements for “protective separation” in electrical equipment
- IEC 255, DIN VDE 0109:
Insulation coordination for equipment within low-voltage systems, including clearance and creepage distances for configured printed circuit boards
- DIN VDE 0435:
Electrical relays, switching relays

Input circuit

Rated voltage [V]	Reference voltage at which the relay coupler works Typical input voltage => 5 Vdc, 12, 24, 48, 60, 115, 230 ac/dc
Rated current [mA]	Quotient of input voltage and input resistance Input resistance => coil resistance + resistance of the triggering device (R; LED; GL, ...)
Nominal consumption [W/VA]	Input voltage x input current dc/ac with tolerance +/-10% or +5/-15% typical range for relay coupler 250 mW > Pv > 1 W 0.4 VA > Pv > 1.2 VA
Operating voltage [V]	Smallest input current needed for the relay coupler to respond (Tu = 293 K)
Pull-in current [mA]	Smallest input current at which the relay switches from idle to working position (Tu = 293 K)
Response power [W/VA]	Product of operating voltage and pull-in current
Drop-out voltage [V]	Voltage at which the relay reliably drops away
Release current [mA]	Input current at which the relay reliably drops away

Output circuit

Max. switching voltage [V]	Max. voltage allowed at the relay contact
Switch-on current [A]	Current allowed to flow for max. 4 seconds after the relay contact closes
Continuous current [A]	Current allowed to flow constantly after the contact closes
Switching power [W/VA]	Product of output voltage and switch-on current, under ohmic, inductive or capacitive load
Min. switching power [µW]	Smallest power to be switched via the contact
Service life	No. of switching cycles until the contact fails – mechanical => without electric load – electrical => under ohmic or inductive ac/dc load
Response time [ms]	Time from closing the exciter voltage until the contact closes/opens
Release time [ms]	Time from opening the exciter voltage until the contact closes/opens
Switching frequency [Hz]	Switching circuits/sec. in pulse duty factor 1:2 (ton = toff)
Voltage strength [kV]	Max. test voltage between input and output circuit which does not cause a discharge
Protective separation	Relay coupler acc. to EN 50178 or VDE 0106 part 101
Light arc	Flow of current on opening contacts, caused by ionisation
Contact wear	The switching of inductivity causes extensive material migration Results: => Scratches and tip formation on contact surfaces => Failure caused by contacts interlocking
Spark extinction	Limitation of transient overvoltage by switching the inductive load: => RC combinations => Z-diodes / suppressor diodes => varistors
Reduction factor	Factor by which the service life is reduced when switching inductive loads

Relay coupler – overview

Enclosure types for relay couplers

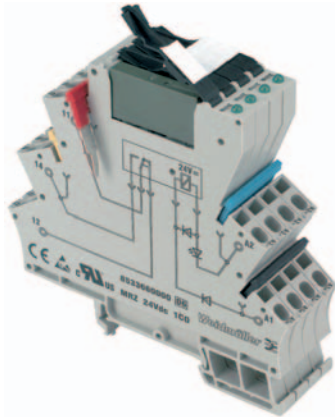
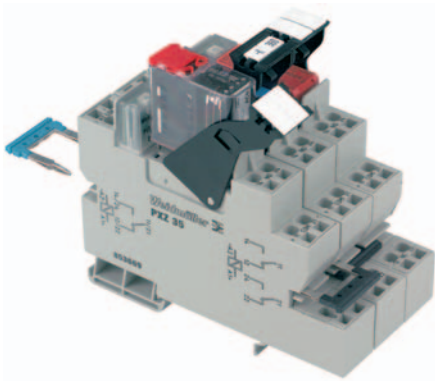

PLUGSERIES

The modular component system represents a new generation of pluggable relay couplers. The key element is an innovative relay base designated PXS (screw clamp) or PXZ (tension clamp). Both products reflect the functionality of relays and terminals, and experience gained from their commercial use. PLUGRELAY is the ideal connection system between the relay and the application.

Modular principle

The new PLUGSERIES is extremely easy to handle. Commercially available relays are simply plugged in, retaining clips provide a firm hold, and LED displays with a freewheel diode can be plugged in.

- Relays simply plugged in: suitable for miniature circuit of both standard and RT designs
- Independent connection technology: screw connection or tension spring technology, nominal cross-sectional area 0.5 ... 2.5 mm²
- Robust design of the retaining clip
- One or two change-over contacts; max. switching current 16 A
- Minimum wiring workload thanks to ZQV 2.5N pluggable cross-connectors
- Modular system makes for easy handling:
 - Relay base, LED display, retaining hook and relay
 - Clips on to TS 35
 - Marking with WS tabs on retaining hook
- Pluggable LED with freewheel diode.

MICROSERIES

Relay and optocoupler versions in the MICROSERIES are used in industrial automation applications for separating and coupling digital input and output signals. The compact design makes them perfectly suited for use in sub-distributors or switch cabinets. With its compact shape, MICROSERIES combines the functions of the classical coupling level with the terminal level.

- Slot-in width 6.1 mm
- Pluggable cross-connection for four input and output potentials
- Tried and tested ZQV 4N cross-connection system
- Wide range of input voltage from 5 .. 230 V
- LED status display, reverse polarity protection diode, recovery diode
- Enclosure material WEMID (combustibility V0 acc. to UL 94)
- Innovative holding and ejecting mechanism
- Marking surface to take standard marking WS 12/6

CE marking

Weidmüller's relay couplers carry the CE mark and comply with the requirements laid down by EN 50 081 part 1 and EN 50 082 part 2. They can be used in both in a wide range of applications and industries

Suitable ESD measures must be taken during installation. Overvoltage protection must be provided for long leads as protection from lightning.

WAVESERIES

Innovative electronic components require an enclosure or housing which reflects their specific functions. It must allow for adjusting and control functions and support technical requirements, such as heat dissipation or electromagnetic compatibility. A compact design saves space in the switch cabinet and reduces assembly costs. Ergonomic design is increasingly important for top quality relay coupler interfaces.

The WAVEBOX fulfils all these criteria, with outstanding features including:

- Assembly without tools
- Pluggable circuit board
- ZQV 2.5V pluggable cross-connector
- Hinged transparent cover
- Marking with WS tabs
- Clips onto TS 35

Connection systems

The user can choose between BLZ screw plug-in connectors and BLZF tension clamp plug-in systems, up to 2.5 mm² and finely stranded, for the greatest possible flexibility when wiring up the circuits.

Printed circuit board

If the lateral locking hook is squeezed on the head end, it can be pulled out of the enclosure together with the connection level and the circuit board. The circuit board can only be pulled out without current voltage.

Cross-connector

The ZQV 2.5 N/2 cross-connectors can be used to connect rows of Wavebox housings in the lower part of the enclosure. The cross-connector can take up to 8 A of current. It can be used for bridging the supply voltage from one electronic module to another. The voltage at the cross-connector must not exceed 50 V.

Ventilation slits

Diagonal ventilation slits ventilate the lower parts of the enclosures and keep temperatures moderate.

Relay coupler – overview

Enclosure types for relay couplers

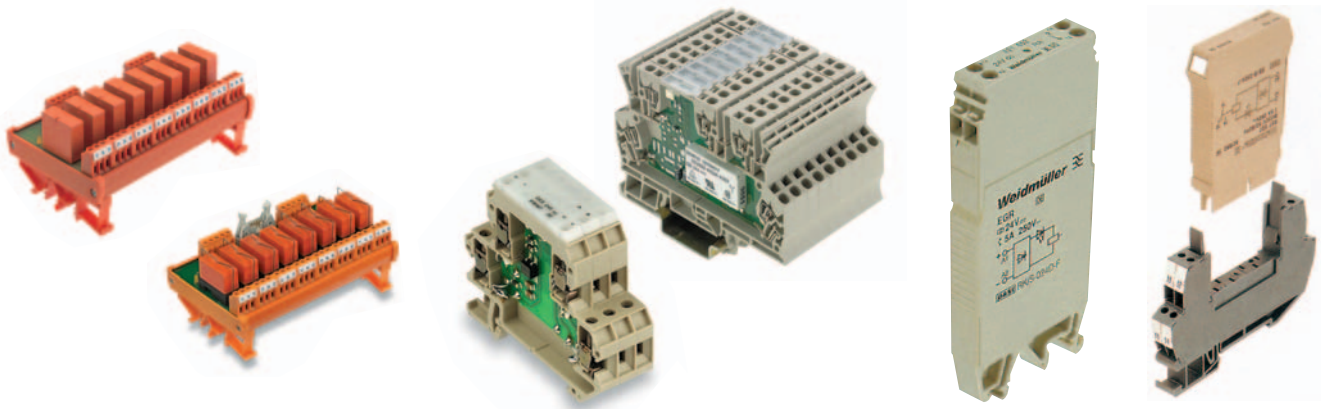

RS SERIES

Clip-in bases with relay RS 30, 31, 32 have a width of 11.2 mm to 25 mm, depending on the type. The open snap-in profile means that relay couplers can be designed for plugging in. The modules on the snap-in base have screw clamp units or flat plug-in connections for connection to the conductor. The following conductors can be connected:

- Solid: 0.5...4 mm²,
- Flexible: 0.5...2.5 mm².

Snap-in base with multiple interface

RSM multiple interfaces are assembled with a choice of 4, 8 or 16 relays. Versions with a joint plus or minus potential are available to save wiring on the input side. LP connection elements are equipped screw connections and are suitable for connecting the following conductor cross-sectional areas:

- Solid: 0.5...4 mm²,
- Flexible: 0.5...2.5 mm².

Variations on the RSM coupler have pre-fabricated male connectors acc. to IEC 603-1/DIN 41 651.

DK SERIES

All components in the DKR mini-coupler are extremely narrow: use of advanced surface-mounted parts (SMD) allows the width to be kept to just 6 mm. The range includes 4 or 5 screw connections for conductor cross-sectional areas of 0.5 ... 4 mm². The mini couplers offer a wide range of applications for coupling digital sensor/actuator signals with automation devices and the process field. DKR relay couplers can be used to pick up and standardise signals from the field with different voltages.

MCZ SERIES

The MCZ enclosure is only 6 mm wide and one of the narrowest of its kind. Its outstanding technical features include:

- Tension clamp connection to reduce assembly costs
- Integrated input/output cross-connection to reduce wiring workload

MCZR mini-conditioners (relay couplers) have 4 or 5 tension clamp connections.

The cross-sectional area of the clamping conductor is 0.5 ... 1.5 mm².

EG SERIES

The EG7 integral enclosure has a special status because it is only suited for the installation of 10 mm narrow relay couplers. EG7 clip-in base can be mounted on either the TS 32 or TS 35. An RS EG7 snap-in base is also available for the RST plug-in relay couplers.

The closed EG 7 enclosures are equipped with screw connections.

Conductors with the following cross-sectional areas can be connected:

- Integral enclosure EG 7: 0.5 ... 1.5 mm²
- Change-over contact RST: 0.5 ... 2.5 mm².

PLUGSERIES

1 change-over contact

Construction kit consists of

- Relay-socket for mounting-rail
- LED-indicator / RC-combination
- Retaining bracket
- Pluggable relay

Cross-connection of the coil connections and change-over contacts of the relay with pluggable cross-connection ZQV 2.5N



DC version

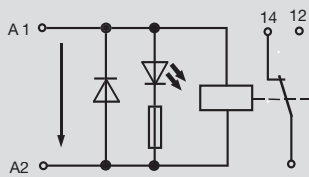

AC version

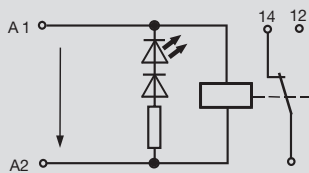

Output

Max. switching voltage AC/Continuous current	250V/10A
Min. switching power	10V/100mA
Response time / Release time	5.8ms/6.9ms
Contact base material	AgNi 90/10
Mechanical endurance	30x10 ⁶ switching cycles
Max. switching frequency at rated load	0.1Hz

Rated data

Status indicator/Free wheel diode/Reverse volt. prot.	LED green/Yes/not available
Ambient temp., fitted w. distance	-25 °C...+50 °C
Storage temperature	-40 °C...+50 °C
Climate	40°C/93% rel. humidity without condensation
Approvals	CE, cURus

Insulation coordinates (EN 50 178)

Standards	EN 50178
Rated voltage	250V
Impulse withstand voltage	6 kV
Creepage and clearance path input - output	>8mm
Overvoltage category	III
Pollution severity	2
Secure separation acc. to VDE 0106 Part 101	Yes

Dimensions

	Screw connection	Tension clamp connection
Clamping range (rating- / min. / max.)	mm ² 2.5 / 0.5 / 2.5	2.5 / 0.5 / 2.5
Length x width x height	mm 92.0 / 15.3 / 95.0	92.0 / 15.3 / 87.0

Information

Applications

K

Max. DC load breaking capacity

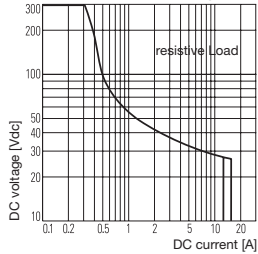

Electrical life

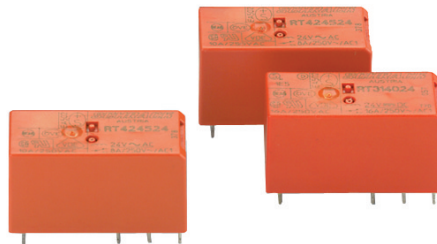
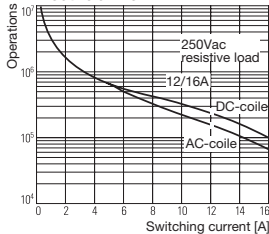

Coil operating range DC

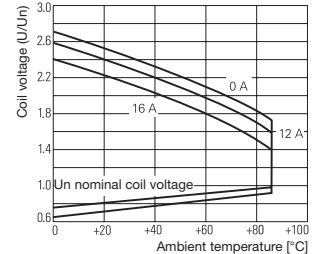

Coil operating range AC

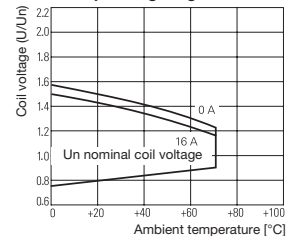

PLUGSERIES

1 change-over contact

Ordering data	12VDC 1CO	24VDC 1CO	115VDC 1CO	24VAC 1CO
Input				
Rated voltage	12 Vdc +/- 20 %	24 Vdc +/- 10 %	115 Vdc +/- 10 %	24 Vac +/- 10 %
Rated current AC				32mA
Rated current DC	33mA	16mA	3.5mA	
Power rating	400mW	400mW	400mW	0.75VA
Oper.-/drop-out volt. AC-coil				17V/3.6V
Oper.-/drop-out volt. DC-coil	8.4V/1.2V	16.8 V / 2.4 V	76 V / 11 V	
Pull-in curr./release curr. AC-coil				
Pull-in curr./release curr. DC-coil				
Ordering data Complete module				
Screw connection Type	PRS 12Vdc LD 1CO	PRS 24Vdc LD 1CO	PRS 115Vdc LD 1CO	PRS 24Vac LD 1CO
Order No.	8536471001	8530621001	8536510000	8536530000
Tension clamp connection Type	PRZ 12Vdc LD 1CO	PRZ 24Vdc LD 1CO	PRZ 115Vdc LD 1CO	PRZ 24Vac LD 1CO
Order No.	8536571001	8530691001	8536610000	8536651001
Ordering data Spare relay, pluggable				
Type	RCL 314012 12Vdc-Rel1U	RCL 314024 24Vdc-Rel1U	RCL 314110 110Vdc-Rel1U	RCL 315524 24Vac-Rel1U
Order No.	4058470000	4058480000	4058500000	4058510000
Information				
Ordering data	120VAC 1CO	230VAC 1CO		
Input				
Rated voltage	120 Vac +/- 10 %	230 Vac +/- 10 %		
Rated current AC	6.6mA	3.2mA		
Rated current DC				
Power rating	0.75VA	0.75VA		
Oper.-/drop-out volt. AC-coil	86.3V/17.3V	171 V / 34 V		
Oper.-/drop-out volt. DC-coil				
Pull-in curr./release curr. AC-coil				
Pull-in curr./release curr. DC-coil				
Ordering data Complete module				
Screw connection Type	PRS 120Vac LD 1CO	PRS 230Vac LD 1CO		
Order No.	8530641001	8530671001		
Tension clamp connection Type	PRZ 120Vac LD 1CO	PRZ 230Vac LD 1CO		
Order No.	8530710000	8530731001		
Ordering data Spare relay, pluggable				
Type	RCL 314615 115Vac-Rel1U	RCL 314730 230Vac-Rel1U		
Order No.	4058520000	4058540000		
Information				



PLUGSERIES

2 change-over contacts

Construction kit consists of

- Relay-socket for mounting-rail
- LED-indicator / RC-combination
- Retaining bracket
- Pluggable relay

Cross-connection of the coil connections and change-over contacts of the relay with pluggable cross-connection ZQV 2.5N



DC version

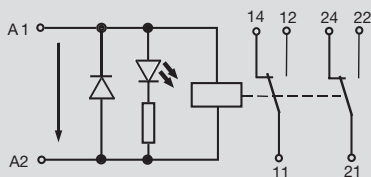

AC version

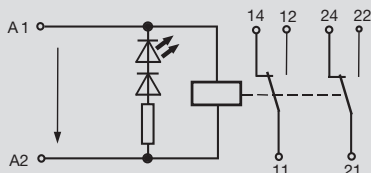

Output

Max. switching voltage AC/Continuous current	250V/10A
Min. switching power	10V/100mA
Response time / Release time	9ms/45ms
Contact base material	AgNi 90/10
Mechanical endurance	5x10 ⁶ switching cycles
Max. switching frequency at rated load	0.1Hz

Rated data

Status indicator/Free wheel diode/Reverse volt. prot.	LED green/No/
Ambient temp., fitted w. distance	-40 °C...+50 °C
Storage temperature	-40 °C...+50 °C
Climate	40°C/93% rel. humidity without condensation
Approvals	CE, cURus

Insulation coordinates (EN 50 178)

Standards	EN 50178
Rated voltage	250V
Impulse withstand voltage	6 kV
Creepage and clearance path input - output	>8mm
Overvoltage category	III
Pollution severity	2
Secure separation acc. to VDE 0106 Part 101	Yes

Dimensions

	Screw connection	Tension clamp connection
Clamping range (rating- / min. / max.)	mm ² 2.5 / 0.5 / 2.5	2.5 / 0.5 / 2.5
Length x width x height	mm 92.0 / 15.3 / 95.0	92.0 / 15.3 / 87.0

Information

Applications

K

Max. DC load breaking capacity

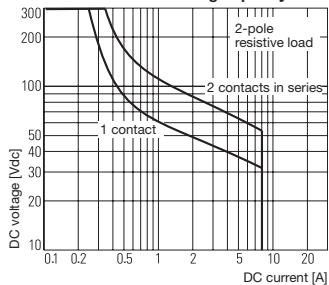

Electrical life

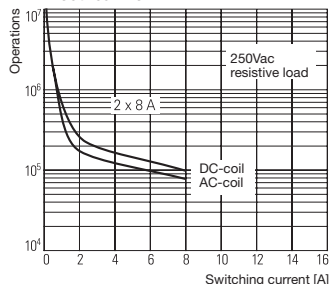

Coil operating range DC

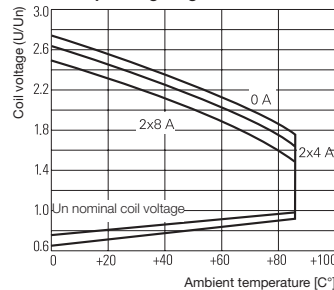

Coil operating range AC

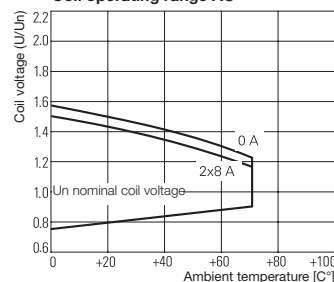

PLUGSERIES

2 change-over contacts

Ordering data	12VDC 2CO	24VDC 2CO	115VDC 2CO	24VAC 2CO
Input				
Rated voltage	12 Vdc +/- 20 %	24 Vdc +/- 10 %	115 Vdc +/- 10 %	24 Vac +/- 10 %
Rated current AC				32mA
Rated current DC	33mA	16mA	3.5mA	
Power rating	400mW	400mW	400mW	0.75VA
Oper.-/drop-out volt. AC-coil				17V/3.6V
Oper.-/drop-out volt. DC-coil	8.4 V / 1.2 V	16.8 V / 2.4 V	76 V / 11 V	
Pull-in curr./release curr. AC-coil				
Pull-in curr./release curr. DC-coil				
Ordering data Complete module				
Screw connection Type	PRS 12Vdc LD 2CO	PRS 24Vdc LD 2CO	PRS 115Vdc LD 2CO	PRS 24Vac LD 2CO
Order No.	8536501001	8530631001	8536520000	8536560000
Tension clamp connection Type	PRZ 12Vdc LD 2CO	PRZ 24Vdc LD 2CO	PRZ 115Vdc LD 2CO	PRZ 24Vac LD 2CO
Order No.	8536591001	8530701001	8536630000	8536681001
Ordering data Spare relay, pluggable				
Type	RCL 424012 12Vdc-Rel2U	RCL 424024 24Vdc-Rel2U	RCL 424110 110Vdc-Rel2U	RCL 424524 24Vac-Rel2U
Order No.	4058560000	4058570000	4058590000	4058600000
Information				
Ordering data	120VAC 2CO	230VAC 2CO		
Input				
Rated voltage	120 Vac +/- 10 %	230 Vac +/- 10 %		
Rated current AC	6.6mA	3.2mA		
Rated current DC				
Power rating	0.75VA	0.75VA		
Oper.-/drop-out volt. AC-coil	86.3V/17.3V	172.5V/34.5V		
Oper.-/drop-out volt. DC-coil				
Pull-in curr./release curr. AC-coil				
Pull-in curr./release curr. DC-coil				
Ordering data Complete module				
Screw connection Type	PRS 120Vac LD 2CO	PRS 230Vac LD 2CO		
Order No.	8530661001	8530681001		
Tension clamp connection Type	PRZ 120Vac LD 2CO	PRZ 230Vac LD 2CO		
Order No.	8530720000	8530741001		
Ordering data Spare relay, pluggable				
Type	RCL 424615 115Vac-Rel2U	RCL 424730 230Vac-Rel2U		
Order No.	4058610000	4058630000		
Information				

Articles with coloured order number are kept permanently in stock at the central warehouse in Germany.
Delivery times see page X.2

PLUGSERIES

2 change-over contacts with gold-plated contacts

Construction kit consists of

- Relay-socket for mounting-rail
- LED-indicator / RC-combination
- Retaining bracket
- Pluggable relay

Cross-connection of the coil connections and change-over contacts of the relay with pluggable cross-connection ZQV 2.5N

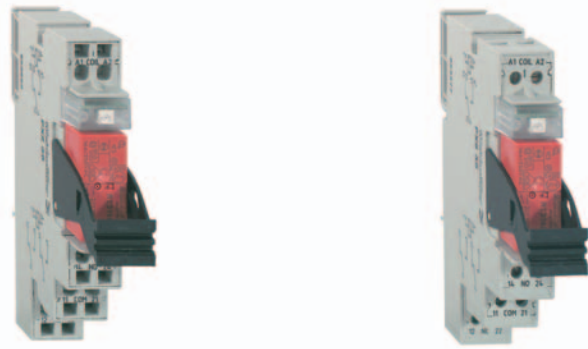

DC version

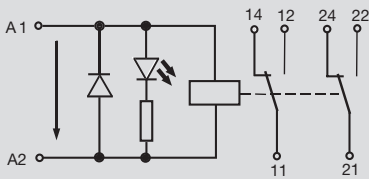

AC version

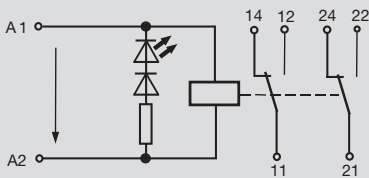

Output

Max. switching voltage AC/Continuous current	250V/10A
Min. switching power	5 V / 10 mA
Response time / Release time	9ms/45ms
Contact base material	AgNi 90/10
Mechanical endurance	5x10 ⁶ switching cycles
Max. switching frequency at rated load	0.1Hz

Rated data

Status indicator/Free wheel diode/Reverse volt. prot.	LED green/No/
Ambient temp., fitted w. distance	-40 °C...+50 °C
Storage temperature	-40 °C...+50 °C
Climate	40°C/93% rel. humidity without condensation
Approvals	CE, cURus

Insulation coordinates (EN 50 178)

Standards	EN 50178
Rated voltage	250V
Impulse withstand voltage	6 kV
Creepage and clearance path input - output	>8mm
Overvoltage category	III
Pollution severity	2
Secure separation acc. to VDE 0106 Part 101	Yes

Dimensions

	Screw connection	Tension clamp connection
Clamping range (rating- / min. / max.)	mm ² 2.5 / 0.5 / 2.5	2.5 / 0.5 / 2.5
Length x width x height	mm 92.0 / 15.3 / 95.0	92.0 / 15.3 / 87.0

Information

Ordering data

Input

	24VDC 2CO AU	120VAC 2CO AU	230VAC 2CO AU
Rated voltage	24 Vdc +/- 10 %	120 Vac +/- 10 %	230 Vac +/- 10 %
Rated current AC		6.6mA	3.2mA
Rated current DC	16mA		
Power rating	400mW	0.75VA	0.75VA
Oper.-/drop-out volt. AC-coil		86.3V/17.3V	172.5V/34.5V
Oper.-/drop-out volt. DC-coil	16.8 V / 2.4 V		
Pull-in curr./release curr. AC-coil			
Pull-in curr./release curr. DC-coil			

Ordering data

Complete module

	24VDC 2CO AU	120VAC 2CO AU	230VAC 2CO AU
Screw connection	PRS 24VDC LD 2COAU	PRS 120VAC LD 2CO AU	PRS 230VAC LD 2CO AU
Order No.	8561760000	8595960000	8595990000
Tension clamp connection	PRZ 24Vdc LD 2CO AU	PRZ 120VAC LD 2COAU	PRZ 230VAC LD 2COAU
Order No.	8552440000	8575940000	8575950000

Ordering data

Spare relay, pluggable

	24VDC 2CO AU	120VAC 2CO AU	230VAC 2CO AU
Type	RCL 425024 24Vdc-Rel2U	RCL 425615 115Vac-Rel2U	RCL 425730 230Vac-Rel2U
Order No.	4058580000	4058620000	4058640000

Information

K

PLUGSERIES

Accessories

Schrack RP3SL

Relay for high switch-on current

Relay coupler

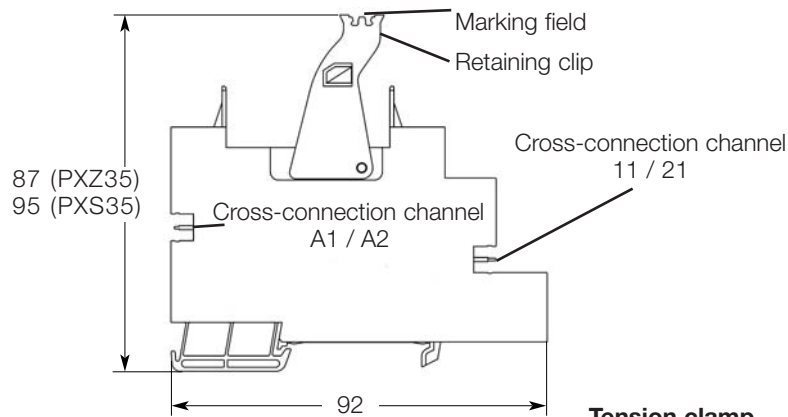

Technical data

Empty base	
Rated current	16 A
Rated voltage	250 V
Voltage resistance coil / contacts	> 4 kV
Protection	IP 20
Nominal cross-sectional area	2,5 mm ²
Stripping length	8 mm
	10 mm
Ambient temperature	-40°C ... +60°C
Flammability acc. to UL 94	V-0

Screw connection
Tension clamp connection

Order data

Empty base for assembly on mounting rail TS 35			
Screw connection	Type	Qty	Order no.
Tension clamp connection	PXS35	10	8533771001
	PXZ35	10	8536691001

Retaining clip			
	PRC	100	8536700000

LED display with freewheel diode			
6 ... 24 Vdc	PLED 24 Vdc	20	8536710000
LED red, 6 ... 24 Vdc	PLED 24 Vdc rot	20	8611010000
48 ... 60 Vdc	PLED 48 Vdc	20	8536720000
115 Vdc	PLED 115 Vdc	20	8536730000
12 ... 24 Vac	PLED 24 Vac	20	8536750000
115 Vac	PLED 120 Vac	20	8536760000
230 Vac	PLED 230 Vac	20	8536780000
LED red, 230 Vac	PLED 230 Vac rot	20	8611000000
RC combination 120...230 VAC/DC	PLRC 200 nF/200Ω	20	8566530000

Plug-in cross-connectors				
2-pole	Black	ZQV 2.5N/4-2SW	60	1784270000
	Red	ZQV 2.5N/4-2RT	60	1784280000
	Blue	ZQV 2.5N/4-2BL	60	1784290000

Marking				
	10 x 5 mm	WS 10/5	200	1060860000
	15 x 5 mm	WS 15/5	96	1609880000

Tension clamp connection

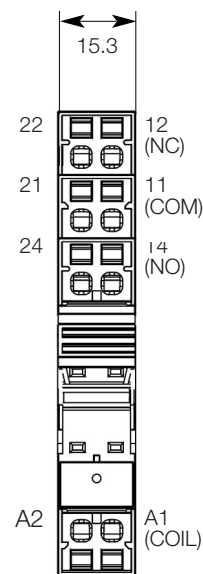

Screw connection

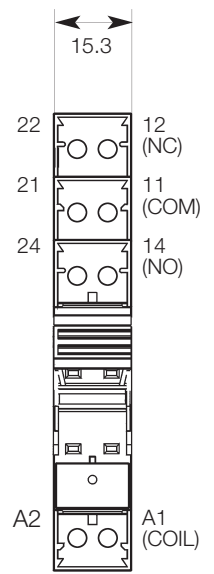

Operating control display

DC version

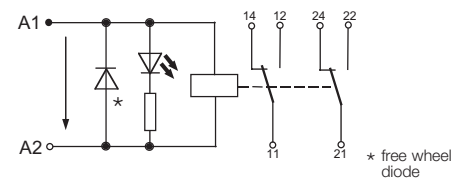

AC version

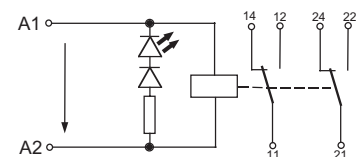

PLUGSERIES

Relay on plug-in base

Schrack RP3SL

- For high switch-on current



Technical data

No. and type of contacts	1 NOC
Contact material	AgSnO ₂
Switching current	25 A
Peak switch-on current	120 A / 20 ms
Switching voltage	250 V
Switching power	4 kVA
Min. switching current / switching power	
Nominal consumption	500 mW
Voltage strength / contact	4 kV
Operating voltage / release time:	DC coil typ. 8 / 2 ms
Bounce time NCC / NOC	typ. 2 ms
Mechanical service life	DC coil 30 x 10 ⁶ switching cycles

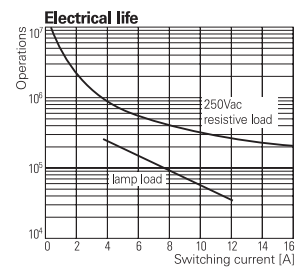

Other data	
Protection class	IP 40
Ambient temperature	DC coil -40°C ... +70°C
Weight	18 g
Approvals	SEV, UL, CSA, VDE

Contact service life	Load	Switching cycles	Regulation
	12 A, 250 V~, cosφ=1	3x10 ⁵	
	TV 8	25x10 ³	UL 508
	2500 W, 230 V~, Halogen lamps	>10 ⁴	
	1000 W, 250 V~, Neon lamps	2.3x10 ⁵	
	3000 W, 250 V~, Neon lamps	3.6x10 ⁴	
	1500 VA, Fluorescent tubes 163 μF	10 ⁴	

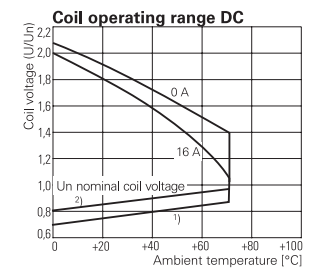

Order data

Pluggable relay	Type	Qty	Order no.
24 Vdc 1 NOC	RP3SL 24 Vdc 1NO	20	8588510000

Articles with coloured order number are kept permanently in stock at the central warehouse in Germany.
Delivery times see page X.2

Base for industrial relays

- Screw or tension clamp technology
- For connecting cross-sectional areas up to 1.5 mm²
- For double and quadruple change-over contact relays
- Insulation in accordance with VDE 0110
- Tension clamp connection
 - Minimum wiring workload
 - Double wiring of all terminals
 - Connections can be cross-connected
 - Separate arrangement of coil and contact connections

Wiring method for tension clamp connection

Place the specified screwdriver in the round tool opening next to the square wire opening

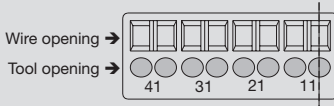

Technical data

Rated current
Rated voltage
Voltage strength coil / contacts
Creepage and clearance path input / output
Protection class
Nominal cross-sectional area
Stripping length
Ambient temperature
Combustibility acc. to UL 94
Approvals

PXZ4

Tension clamp



Rated current	5 A bei 70 °C with MY4 relay
Rated voltage	250 Vac
Voltage strength coil / contacts	2000 Vac
Creepage and clearance path input / output	2000 Vac
Protection class	IP 20
Nominal cross-sectional area	0.2...1.5 mm ² (doubled)
Stripping length	8 mm
Ambient temperature	max. 70 °C
Combustibility acc. to UL 94	V-1
Approvals	

PXS4

Screw connection



Rated current	5 A bei 70 °C with MY4 relay
Rated voltage	250 Vac
Voltage strength coil / contacts	2000 Vac
Creepage and clearance path input / output	2000 Vac
Protection class	IP 20
Nominal cross-sectional area	0.2...1.5 mm ²
Stripping length	8 mm
Ambient temperature	max. 70 °C
Combustibility acc. to UL 94	V-1
Approvals	

Order data

Empty base for mounting rail assembly TS 35	
Type	PXZ4

Type	Qty	Order no.
PXZ4	10	8598710000

Type	Qty	Order no.
PXS4	10	8614350000

Accessories

Retaining clip	
Relay, type: MY4	
Relay, type: PT5	

Type	Qty	Order no.
PXZ4-PIRC	50	8598610000
PT 28802	25	8572170000

Type	Qty	Order no.
PXS4-PIRC	100	8633920000

Marking	
for PXZ4-PIRC only	

Type	Qty	Order no.
WS PXZ4	100	8598630000

Type	Qty	Order no.

Cross-connector	
2-pole	Blue
	Red

Type	Qty	Order no.
ZQV PXZ4-bl	50	8611090000
ZQV PXZ4-rt	50	8611100000

Type	Qty	Order no.

Screwdriver	

Type	Qty	Order no.
SD	1	9009030000

Type	Qty	Order no.

Miniature power relay MY4

- Relay with 4 change-over contacts
- With DC or AC voltage coil
- Mechanical operating display
- Integrated LED for optical operating display
- Test button (blue = DC coil, red = AC coil)
- Cadmium-free contacts with 3 µm gold plating
- For plugging onto Weidmüller base PXZ4 and PXS4

MY4 IN / MY4 IN1

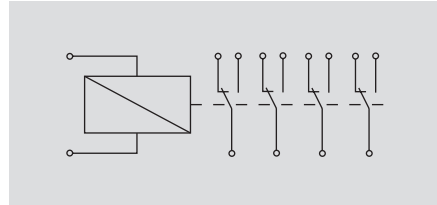
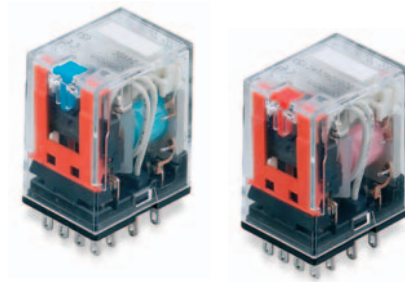

Technical data

Coil data	
Rated voltage	
Rated power	
Operating voltage/release voltage	
Contact data	
No. of contacts	
Contact material	
Rated current	
Switching voltage max.	DC coil / AC coil
Max. switching power AC	
Switching current	
Recommended min. load	
General data	
Flammability class acc. to UL 94	
Ambient temperature	
Mechanical service life	DC coil / AC coil
Response/release time	
Duration of bounce	
Weight	
Dimensions (width x height x length)	
Insulation	
Voltage strength coil-contact	
Insulation acc. to IEC 664 / VDE 0110 (1/89)	
Rated voltage / pollution severity / overvoltage category	
Insulation acc. to VDE 0110b (2/79)	
Insulation group/reference voltage	

DC coil	AC coil
12 / 24 / 110 V-	24 / 120 / 230 V~
Typically 0.9 W	Typically 1.0 VA
80 / 10 (% rated voltage)	80 / 30 (% rated voltage)
4 change-over contacts	
AgNi with 3µm Au plating	
4 x 5 A	
125 V- / 250 V~	
1250 VA	
4 x 5 A	
5 Vdc, 10 mA	
V-2	
-55...+70 °C	
>10x10 ⁷ / >50x10 ⁶	
20 / 20 ms	
max. 20 ms	
35 g	
21.5 x 36 x 28 mm	
2000 Vac	
240 V / 2 / II	
A250 / B125	

Order data

DC coil	Type	Qty	Order no.
12 Vdc	MY4 IN1-12	10	8598660000
24 Vdc	MY4 IN1-24	10	8598700000
110 Vdc	MY4 IN1-110	10	8598640000
AC coil	Type	Qty	Order no.
24 Vac	MY4 IN-24	10	8598690000
120 Vac	MY4 IN-120	10	8598650000
230 Vac	MY4 IN-230	10	8598670000

Other relays on request

Breaking capacity

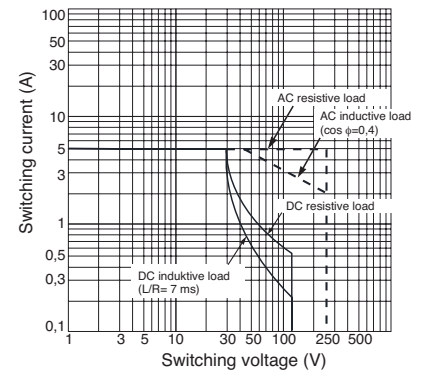

Lifetime (inductive load)

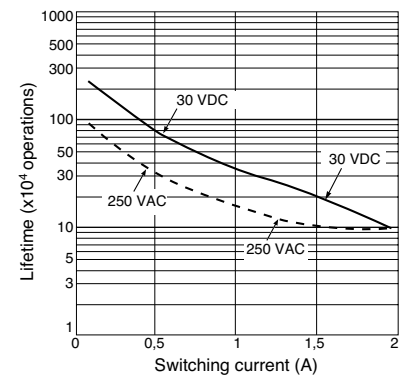

Lifetime (resistive load)

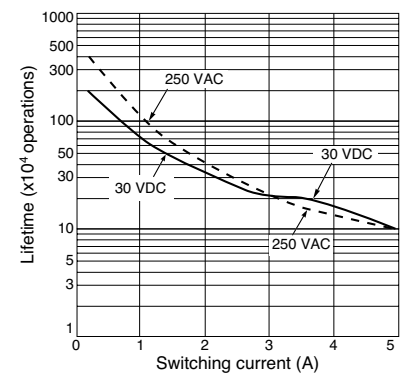

Miniature power relay PT 5

- Relay with 4 change-over contacts
- With DC or AC voltage coil
- Mechanical operating display
- Locking test button
- Cadmium-free contact material
- For plugging onto Weidmüller base PXZ4 with retaining clip PT 28802

PT 5

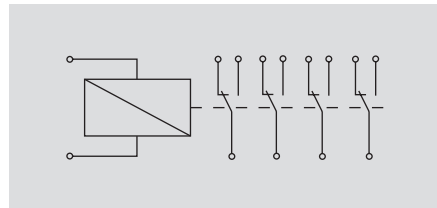

Technical data

Coil data	
Rated voltage	6...220 V-
Rated power	Typically 0.75 W
Operating voltage/release voltage	75 / 10 (% rated voltage)
Working range AC coil, 60 Hz at 70°C	90...110 % U _{rated}
Contact data	
No. of contacts	4 change-over contacts
Contact material	AgNi 90 / 10, AgNi 90 / 10 htv
Rated current	4 x 6 A
Switching voltage max.	250 Vac
Max. switching power AC	1500 VA
Switching current	4 x 6 A
Recommended min. load	24 V, 10 mA / 20 mV, 1 mA htv
General data	
Flammability class acc. to UL 94	V-0
Ambient temperature	-40...+70°C
Mechanical service life	> 30 x 10 ⁶ (DC coil), > 20 x 10 ⁶ (AC coil)
Response/release time	15 / 10 ms
Duration of bounce	5 ms
width x height x length	22.5 x 30 x 28 mm
Insulation	
Voltage strength coil-contact	2500 V _{eff}
Insulation acc. to IEC 664 / VDE 0110 (1/89)	
Rated voltage / pollution severity / overvoltage category	240 V / 2 / III
Insulation acc. to VDE 0110b (2/79)	
Insulation group/reference voltage	B / 250

DC coil	AC coil
Rated voltage	6...230 V~
Rated power	Typically 1.0 VA
Operating voltage/release voltage	80 / 10 (% rated voltage)
Working range AC coil, 60 Hz at 70°C	90...110 % U _{rated}
No. of contacts	4 change-over contacts
Contact material	AgNi 90 / 10, AgNi 90 / 10 htv
Rated current	4 x 6 A
Switching voltage max.	250 Vac
Max. switching power AC	1500 VA
Switching current	4 x 6 A
Recommended min. load	24 V, 10 mA / 20 mV, 1 mA htv
Flammability class acc. to UL 94	V-0
Ambient temperature	-40...+70°C
Mechanical service life	> 30 x 10 ⁶ (DC coil), > 20 x 10 ⁶ (AC coil)
Response/release time	15 / 10 ms
Duration of bounce	5 ms
width x height x length	22.5 x 30 x 28 mm
Voltage strength coil-contact	2500 V _{eff}
Insulation acc. to IEC 664 / VDE 0110 (1/89)	
Rated voltage / pollution severity / overvoltage category	240 V / 2 / III
Insulation acc. to VDE 0110b (2/79)	
Insulation group/reference voltage	B / 250

Order data

DC coil	
6 Vdc	PT 570006
12 Vdc	PT 570012
24 Vdc	PT 570024
48 Vdc	PT 570048
60 Vdc	PT 570060
115 Vdc	PT 570110
220 Vdc	PT 570220
AC coil	
6 Vac	PT 570506
12 Vac	PT 570512
24 Vac	PT 570524
48 Vac	PT 570548
60 Vac	PT 570560
115 Vac	PT 570615
230 Vac	PT 570730

Type	Qty	Order no.
PT 570006	10	8074650000
PT 570012	10	8054360000
PT 570024	10	1180700000
PT 570048	10	8074670000
PT 570060	10	8074680000
PT 570110	10	8074700000
PT 570220	10	8636230000
PT 570506	10	8074710000
PT 570512	10	8074730000
PT 570524	10	1181800000
PT 570548	10	1180900000
PT 570560	10	8074760000
PT 570615	10	1180800000
PT 570730	10	1181100000

Other relays on request

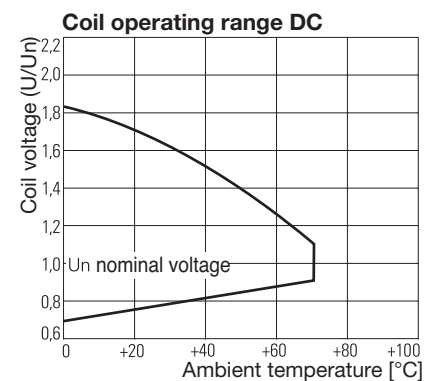
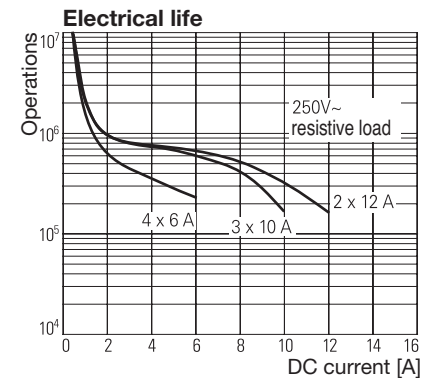
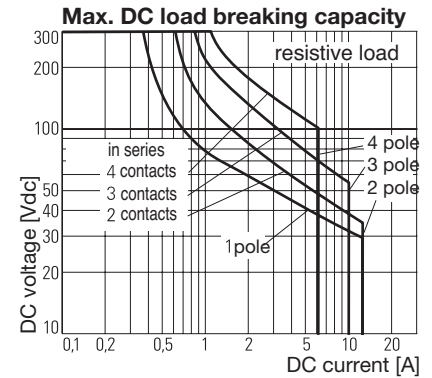

MICROSERIES

1 change-over contact

Module can be used as an universal interface between control and actuator for switching small and medium loads

- The pluggable cross-connection in input and output minimizes the effort to wire
- Width 6.1 mm
- Relay interchangeable, also with opto-couplers

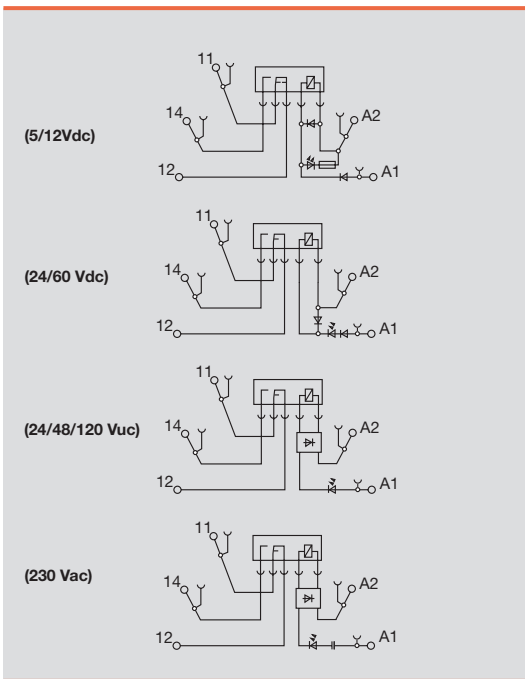
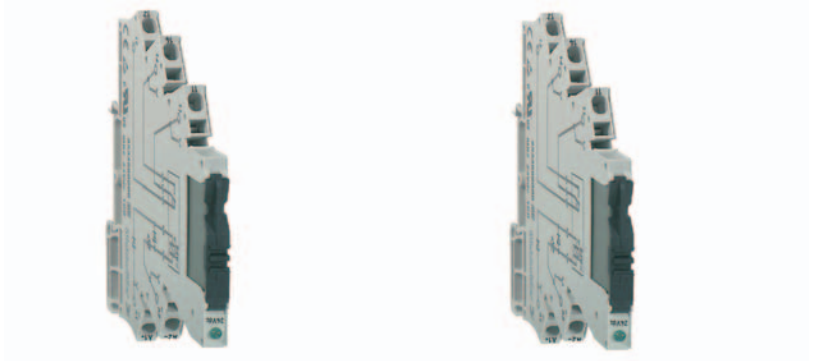

Output	
Max. switching voltage AC/Continuous current	250V/6A
Min. switching power	12V/100mA
Response time / Release time	6.2ms/3.9ms
Contact base material	AgSnO
Mechanical endurance	20x10 ⁶ switching cycles
Max. switching frequency at rated load	0.1Hz
Rated data	
Status indicator/Free wheel diode/Reverse volt. prot.	LED green/Yes/available
Ambient temp., fitted w. distance	-25 °C...+50 °C
Storage temperature	-40 °C...+60 °C
Climate	40°C/93% rel. humidity without condensation
Approvals	CE, cURus
Insulation coordinates (EN 50 178)	
Standards	EN 50178
Rated voltage	300 V
Impulse withstand voltage	4 kV
Creepage and clearance path input - output	=>5.5mm
Overtoltage category	III
Pollution severity	2
Secure separation acc. to VDE 0106 Part 101	Yes

Dimensions	Screw connection	Tension clamp connection
Clamping range (rating- / min. / max.)	mm ² 2.5 / 0.5 / 4	1.5 / 0.5 / 2.5
Length x width x height	mm 93.0 / 6.1 / 92.0	94.0 / 6.1 / 91.0

Information

Applications

K

DC-load breaking capacity

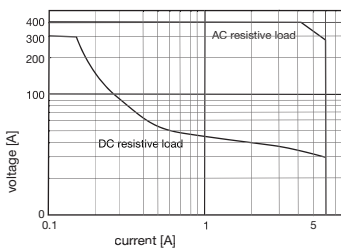

Derating curve

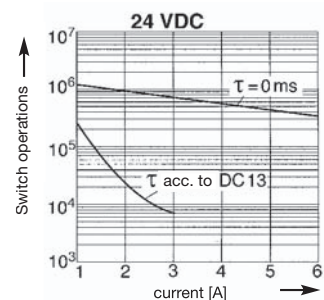
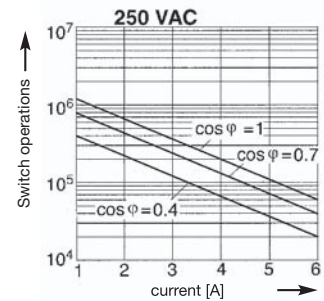
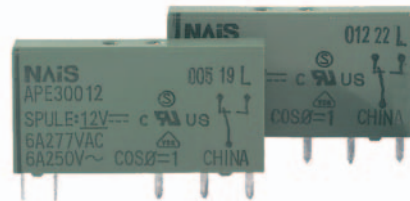
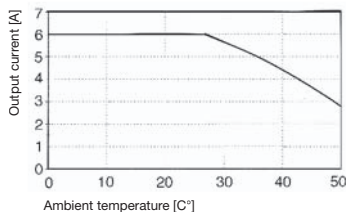

MICROSERIES

1 change-over contact

Ordering data	5VDC 1CO	12VDC 1CO	24VDC 1CO	24VUC 1CO
Input				
Rated voltage	5 Vdc +/- 20 %	12 Vdc +/- 20 %	24 Vdc +/- 20 %	24 Vuc +/- 10 %
Rated current AC				11mA
Rated current DC	38.5mA	17mA	6.6mA	6.4mA
Power rating	193mW	210mW	160mW	154mW
Oper.-/drop-out volt. AC-coil				15.8V/7V
Oper.-/drop-out volt. DC-coil	3.2V/1.6V	6.4V/2.5V	15.4V/6.5V	15.8V/7V
Pull-in curr./release curr. AC-coil				3.6mA/1.3mA
Pull-in curr./release curr. DC-coil	21.6mA/8mA	8.4mA/2.4mA	4mA/1.2mA	3.6mA/1.3mA
Ordering data Complete module				
Screw connection Type	MRS 5Vdc 1CO	MRS 12Vdc 1CO	MRS 24Vdc 1CO	MRS 24Vuc 1CO
Order No.	8556080000	8556070000	8533640000	8556050000
Tension clamp connection Type	MRZ 5Vdc 1CO	MRZ 12Vdc 1CO	MRZ 24VDC 1U	MRZ 24Vuc 1CO
Order No.	8556150000	8556140000	8533660000	8556120000
Ordering data Spare relay, pluggable				
Type	APE 30005V 05Vdc-Rel1U	APE 30012V 12Vdc-Rel1U	APE 30024V 24Vdc-Rel1U	APE 30024V 24Vdc-Rel1U
Order No.	4061580000	4061610000	4060120000	4060120000
Information				
Ordering data	48VUC 1CO	60VDC 1CO	120VUC 1CO	230VAC 1CO
Input				
Rated voltage	48 Vuc +/- 10 %	60 Vdc +/- 20 %	120 Vuc +10 %/ -15 %	230 Vac +/- 10 %
Rated current AC	5mA		3.5mA	7.6mA
Rated current DC	4mA	3.3mA	3.5mA	
Power rating	190mW	200mW	0.42VA	1.75VA
Oper.-/drop-out volt. AC-coil	29V/11V		71V/22V	103V/49V
Oper.-/drop-out volt. DC-coil	29V/11V	35V/11V	71V/22V	103V/49V
Pull-in curr./release curr. AC-coil	2.2mA/1.3mA		1.8mA/0.5mA	5mA/2.5mA
Pull-in curr./release curr. DC-coil	2.2mA/1.3mA	1.6mA/0.6mA	1.8mA/0.5mA	5mA/2.5mA
Ordering data Complete module				
Screw connection Type	MRS 48Vuc 1CO	MRS 60Vdc 1CO	MRS 120Vuc 1CO	MRS 230Vac 1CO
Order No.	8556040000	8556060000	8556030000	8556020000
Tension clamp connection Type	MRZ 48Vuc 1CO	MRZ 60Vdc 1CO	MRZ 120Vuc 1CO	MRZ 230Vac 1CO
Order No.	8556110000	8556130000	8556100000	8556090000
Ordering data Spare relay, pluggable				
Type	APE 30048V 48Vdc-Rel1U	APE 30060V 60Vdc-Rel1U	APE 30060V 60Vdc-Rel1U	APE 30024V 24Vdc-Rel1U
Order No.	4061620000	4061630000	4061630000	4060120000
Information				

K

MICROSERIES

1 change-over contact with gold-plated contact

Module can be used as an universal interface between control and actuator for switching small and medium loads

- The pluggable cross-connection in input and output minimizes the effort to wire
- Width 6.1 mm
- Relay interchangeable, also with opto-couplers

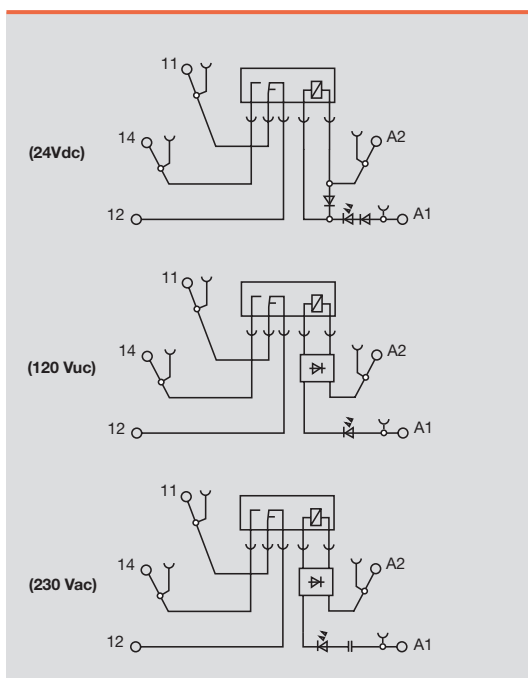
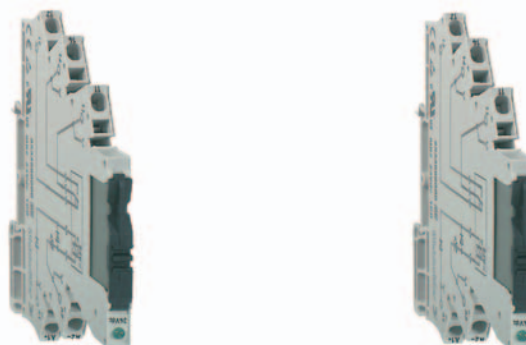

Output	
Max. switching voltage AC/Continuous current	250V/6A
Min. switching power	12V/10mA
Response time / Release time	6.6ms/5.8ms
Contact base material	AgSnO 5 #03BCm Au
Mechanical endurance	20x10^6 switching cycles
Max. switching frequency at rated load	0.1Hz
Rated data	
Status indicator/Free wheel diode/Reverse volt. prot.	LED green/Yes/available
Ambient temp., fitted w. distance	-25 °C...+50 °C
Storage temperature	-40 °C...+60 °C
Climate	40°C/93% rel. humidity without condensation
Approvals	CE, cURus
Insulation coordinates (EN 50 178)	
Standards	EN 50178
Rated voltage	300 V
Impulse withstand voltage	4 kV
Creepage and clearance path input - output	=>5.5mm
Overvoltage category	III
Pollution severity	2
Secure separation acc. to VDE 0106 Part 101	Yes

Dimensions	Screw connection	Tension clamp connection
Clamping range (rating- / min. / max.)	mm ² 2.5 / 0.5 / 4	1.5 / 0.5 / 2.5
Length x width x height	mm 93.0 / 6.1 / 92.0	94.0 / 6.1 / 91.0

Information	

Ordering data

Input	24VDC 1CO 5uAU	230VAC 1CO 5uAU		
Rated voltage	24 Vdc +/- 20 %	230 Vac +/- 10 %		
Rated current AC		7.6mA		
Rated current DC	6.6mA			
Power rating	160mW	1.75VA		
Oper.-/drop-out volt. AC-coil		103V/49V		
Oper.-/drop-out volt. DC-coil	15.4V/6.5V	103V/49V		
Pull-in curr./release curr. AC-coil		5mA/2.5mA		
Pull-in curr./release curr. DC-coil	4mA/1.2mA	5mA/2.5mA		

Ordering data

Complete module				
Screw connection	Type MRS 24Vdc 1CO 5uAu	Type MRS 230Vac 1CO 5uAu		
Order No.	8596060000	8596050000		
Tension clamp connection	Type MRZ 24Vdc 1CO 5uAu	Type MRZ 230Vac 1CO 5uAu		
Order No.	8596080000	8596070000		

Ordering data

Spare relay, pluggable				
Type	APE 30124V 24Vdc-Rel1U	Type APE 30124V 24Vdc-Rel1U		
Order No.	4061590000	4061590000		

Information				

K

MICROSERIES

Accessories

General data – MICROSERIES

Pluggable cross-connector

Type	No. of poles	Qty	Order no.
Yellow			
ZQV 4N / 2 GE	2	60	1758250000
ZQV 4N / 3 GE	3	60	1762630000
ZQV 4N / 4 GE	4	60	1762620000
ZQV 4N / 10 GE	10	20	1758260000
ZQV 4N / 41 GE	41	10	1758270000
Red			
ZQV 4N / 2 RT	2	60	1793950000
ZQV 4N / 3 RT	3	60	1793980000
ZQV 4N / 4 RT	4	60	1794010000
ZQV 4N / 10 RT	10	20	1794040000
ZQV 4N / 41 RT	41	10	1794070000
Blue			
ZQV 4N / 2 BL	2	60	1793960000
ZQV 4N / 3 BL	3	60	1793990000
ZQV 4N / 4 BL	4	60	1794020000
ZQV 4N / 10 BL	10	20	1794050000
ZQV 4N / 41 BL	41	10	1794080000
Black			
ZQV 4N / 2 SW	2	60	1793970000
ZQV 4N / 3 SW	3	60	1794000000
ZQV 4N / 4 SW	4	60	1794030000
ZQV 4N / 10 SW	10	20	1794060000
ZQV 4N / 41 SW	41	10	1794090000

Technical data

Clamping conductor		Tension clamp connection	Screw connection
Solid H07V-U	mm ²	0.5 ... 2.5	0.5 ... 4.0
Flexible H07V-K	mm ²	0.5 ... 2.5	0.5 ... 2.5
"f" with ferrule acc. to DIN 46 228 / 1	mm ²	0.5 ... 1.5	0.5 ... 1.5
"f" with ferrule with plastic collar	mm ²	0.5 ... 1.5	0.5 ... 1.5
Max. clamping range	mm ²	0.13 ... 2.5	0.13 ... 4.0
Plug gauge acc. to IEC 60-947-1	Size	A 2	A 3

General technical data

Rated torque		-	0,6
Continuous output current of the 2-pole cross-connector	A	10	10
Continuous output current of the multi-pole cross-connector A		10	10
Stripping length	mm	10	7
Protection class		IP 20	IP 20
Enclosure material		Wemid	Wemid
Flammability class acc. to UL 94		V-0	V-0
Rated current	A	6	6
Rated voltage	V	250	250

Other accessories

Type		Qty	Order no.
Marker			
WS 12/6	12 x 6 mm	200	1061160000
Labels, laser mark			
LM MT 300 15/6 ge	484 Labels / sheet	10	1686360000
Screwdriver			
SD 0.6 x 3.5 x 100		10	9008330000

Dimensional drawings

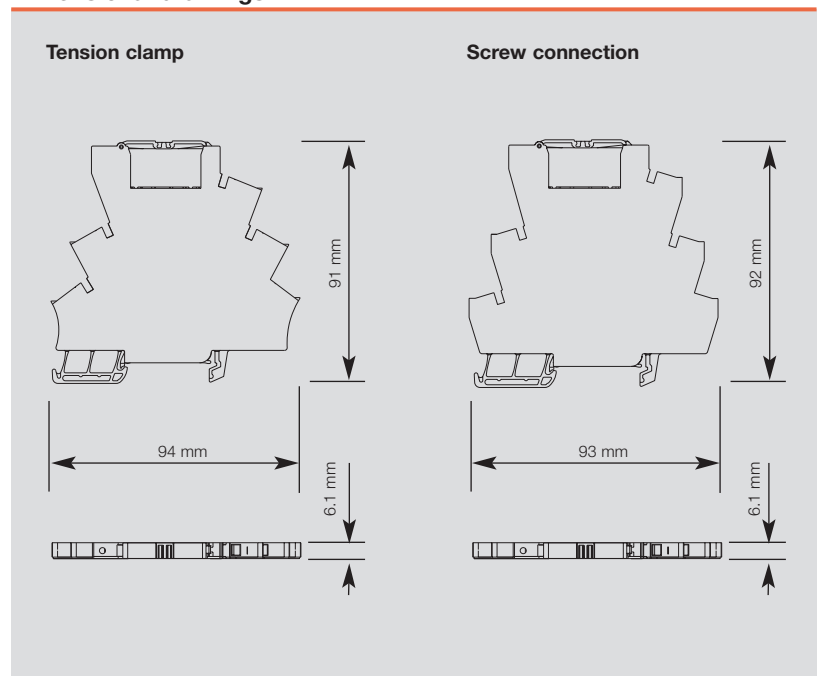

WAVESERIES

1 change-over contact

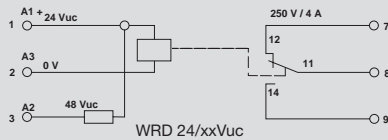
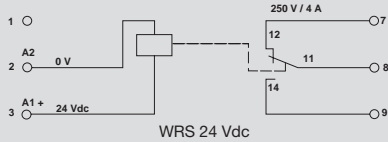
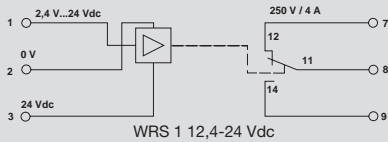

Output

Max. switching voltage AC/Continuous current	250V/5A
Min. switching power	100mA/5Vdc
Response time / Release time	7ms/6ms
Contact base material	Ag alloy
Mechanical endurance	20x10^6 switching cycles
Max. switching frequency at rated load	0.1Hz

Rated data

Status indicator/Free wheel diode/Reverse volt. prot.	LED green/Yes/available
Ambient temp., fitted w. distance	-25 °C...+50 °C
Storage temperature	-40 °C...+60 °C
Climate	40°C/93% rel. humidity without condensation
Approvals	UL / CSA

Insulation coordinates (EN 50 178)

Standards	EN 50178
Rated voltage	300 V
Impulse withstand voltage	6 kV (1.2/50 µ)
Creepage and clearance path input - output	=>5.5mm
Overtoltage category	III
Pollution severity	2
Secure separation acc. to VDE 0106 Part 101	Yes

Dimensions

	Screw connection	Tension clamp connection
Clamping range (rating- / min. / max.)	mm²	1.5 / 0.5 / 2.5
Length x width x height	mm	72.0 / 22.5 / 92.4

Information

Applications

Mounted horizontally

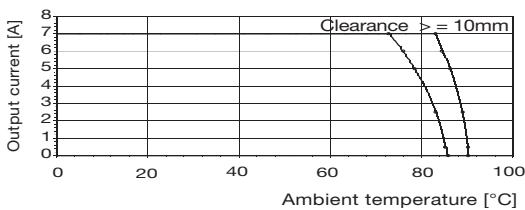

K

WAVESERIES

1 change-over contact

Ordering data	2.4-24VDC 1CO	24VDC 1CO	24/48VUC 1CO	24/60VUC 1CO
Input				
Rated voltage	2.4...24 Vdc +/- 10 %	24 Vdc +/- 10 %	24 Vuc // 48 Vuc, +/- 10 %	24 Vuc // 60 Vuc, +/- 10 %
Rated current AC			approx. 14mA	approx. 11mA
Rated current DC	4.6mA	9mA	14 mA	approx. 10mA
Power rating	200 mW	220mW	0.35VA(W) // 0.5VA(W)	0.22W / 0.34VA // 0.6W / 0.7VA
Oper.-/drop-out volt. AC-coil			16 V/9.5 V // 29 V/15 V	16 V/9.5 V // 31 V/20 V
Oper.-/drop-out volt. DC-coil	1.9 V	16 V/7.5 V	16 V/9.5 V // 29 V/15 V	15 V/8.5V // 34 V/15 V
Pull-in curr./release curr. AC-coil			9 mA/4.5 mA // 8.3mA/4.1mA	5.6mA/2.3mA // 5.6mA/2.1mA
Pull-in curr./release curr. DC-coil	3.88mA	5.7 mA/2.2 mA	9 mA/4.5 mA // 8.3mA/4.1mA	5.8 mA/3.9 mA // 5.6 mA/3.4 mA
Ordering data Complete module				
Screw connection Type	WRS1 2.4-24VDC 1U	WRS1 24VDC 1U	WRS1 24/48VUC 1U	WRS1 24/60VUC 1U
Order No.	8275320000	8275350000	8286280000	8418210000
Tension clamp connection Type				
Order No.				
Ordering data Spare relay, pluggable				
Type				
Order No.				
Information				
Ordering data	24/115VUC 1CO	24VUC/230VAC 1CO		
Input				
Rated voltage	24 Vuc // 115 Vuc, +/- 10 %	24 Vuc // 230 Vac, +/- 10 %		
Rated current AC	approx. 11mA	approx. 15mA		
Rated current DC	approx. 10mA	14mA (24Vdc)		
Power rating	0.22W / 0.34VA // 1.2W / 1.3VA	0.34VA / 0.32W // 3.5VA		
Oper.-/drop-out volt. AC-coil	15 V/12 V // 60 V/34 V	13 V/9 V // 115 V/66 V		
Oper.-/drop-out volt. DC-coil	16V/8.5V // 64V/26V	13 V/9 V (24Vdc)		
Pull-in curr./release curr. AC-coil	5.8mA/3.9mA // 5.5mA/3mA	7.5 mA/4.7 mA // 7.4 mA/4.3 mA		
Pull-in curr./release curr. DC-coil	5.6mA/2.3mA // 5.7mA/2.2mA	7.5 mA/4.7 mA		
Ordering data Complete module				
Screw connection Type	WRS1 24/115VUC 1U	WRS1 24VUC/230VAC 1U		
Order No.	8418220000	8418230000		
Tension clamp connection Type				
Order No.				
Ordering data Spare relay, pluggable				
Type				
Order No.				
Information				

Articles with coloured order number are kept permanently in stock at the central warehouse in Germany.
Delivery times see page X.2

WAVESERIES

2 NO contacts

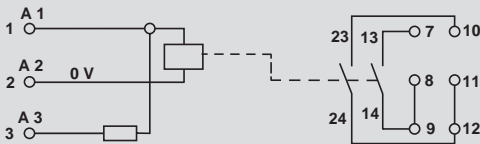
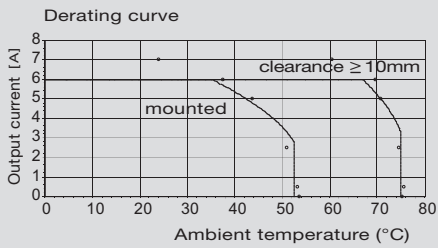

Output	
Max. switching voltage AC/Continuous current	250V/5A
Min. switching power	100mA/5Vdc
Response time / Release time	5ms/6ms
Contact base material	AgSnO2
Mechanical endurance	50x10 ⁶ switching cycles
Max. switching frequency at rated load	0.1Hz
Rated data	
Status indicator/Free wheel diode/Reverse volt. prot.	LED green/Yes/available
Ambient temp., fitted w. distance	-25 °C...+50 °C
Storage temperature	-40 °C...+60 °C
Climate	40°C/93% rel. humidity without condensation
Approvals	UL / CSA
Insulation coordinates (EN 50 178)	
Standards	EN 50178
Rated voltage	300 V
Impulse withstand voltage	6 kV (1.2/50 μ)
Creepage and clearance path input - output	=>8mm
Overtoltage category	III
Pollution severity	2
Secure separation acc. to VDE 0106 Part 101	Yes

Dimensions	Screw connection	Tension clamp connection
Clamping range (rating- / min. / max.)	mm ² 1.5 / 0.5 / 2.5	
Length x width x height	mm 92.4 / 22.5 / 112.4	

Information

Ordering data

Input	12/24VDC 2A	24/48VUC 2A	115VUC/230VAC 2A	
Rated voltage	12 Vdc // 24 Vdc, +/- 10 %	24 Vuc // 48 Vuc, +/- 10 %	115 Vuc // 230 Vac, +/- 10 %	
Rated current AC		approx. 11mA	approx. 10mA	
Rated current DC	approx. 20mA	approx. 8.5mA	9mA (115Vdc)	
Power rating	0.24W // 0.5W	0.17W / 0.21VA // 0.4W / 0.48VA	1VA / 0.9W // 2.5VA	
Oper.-/drop-out volt. AC-coil		13.5 V / 9 V // 24 V/16 V	58 V / 22 V // 110 V/40 V	
Oper.-/drop-out volt. DC-coil	7.5 V / 3.5 V // 14.5 V/6.1 V	16 V / 7.8 V // 28 V/12 V	54 V / 20 V (115Vdc)	
Pull-in curr./release curr. AC-coil		4.4 mA/2.7 mA // 4.3 mA/2.6 mA	4.8 mA/1.7 mA // 5 mA/2 mA	
Pull-in curr./release curr. DC-coil	10 mA/4.2 mA // 10 mA/4 mA	4.3 mA/1.6 mA // 4.4 mA/1.6 mA	4 mA/2 mA	

Ordering data

Complete module				
Screw connection	Type	WRS2 12/24VDC 2A	WRS2 24/48VUC 2A	WRS2 115VUC/230VAC 2A
	Order No.	8418240000	8418250000	8418260000
Tension clamp connection	Type			
	Order No.			

Ordering data

Spare relay, pluggable				
	Type			
	Order No.			

Information

--	--	--	--	--

K

WAVESERIES

1 NC contact / 1 NO contact



Relay coupler

Derating curve

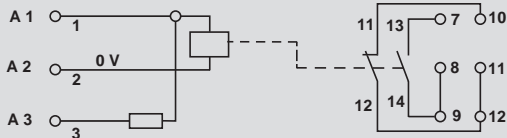
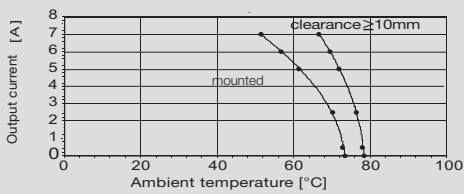

Output	
Max. switching voltage AC/Continuous current	250V/5A
Min. switching power	100mA/5V
Response time / Release time	7ms/5ms
Contact base material	AgSnO2
Mechanical endurance	50x10^6 switching cycles
Max. switching frequency at rated load	0.1Hz
Rated data	
Status indicator/Free wheel diode/Reverse volt. prot.	LED green/Yes/available
Ambient temp., fitted w. distance	-25 °C...+50 °C
Storage temperature	-40 °C...+60 °C
Climate	40°C/93% rel. humidity without condensation
Approvals	UL / CSA
Insulation coordinates (EN 50 178)	
Standards	EN 50178
Rated voltage	300 V
Impulse withstand voltage	6 kV (1.2/50 µ)
Creepage and clearance path input - output	=>8mm
Overtoltage category	III
Pollution severity	2
Secure separation acc. to VDE 0106 Part 101	Yes

Dimensions	Screw connection	Tension clamp connection
Clamping range (rating- / min. / max.)	mm²	1.5 / 0.5 / 2.5
Length x width x height	mm	92.4 / 22.5 / 112.4

Information

Ordering data

Input	12/24VDC 1A 1R	24/48VUC 1A1R	115VUC/230VAC 1A 1R	
Rated voltage	12 Vdc // 24 Vdc, +/- 10 %	24 Vuc // 48 Vuc, +/- 10 %	115 Vuc // 230 Vac, +/- 10 %	
Rated current AC		approx. 11mA	approx. 10mA	
Rated current DC	approx. 20mA	approx. 8.5mA	9mA (115Vdc)	
Power rating	0.24W // 0.5W	0.17W / 0.21VA // 0.4W / 0.48VA	1VA / 0.9W // 2.5VA	
Oper.-/drop-out volt. AC-coil		13.5 V / 9 V // 24 V/16 V	58 V / 22 V // 110 V/40 V	
Oper.-/drop-out volt. DC-coil	7.5 V / 3.5 V // 14.5 V/6.1 V	13.5 V / 9 V // 24 V/16 V	54 V / 20 V (115Vdc)	
Pull-in curr./release curr. AC-coil		4.4 mA/2.7 mA // 4.3 mA/1.6 mA	4.8 mA/1.7 mA // 5 mA/2 mA	
Pull-in curr./release curr. DC-coil	10 mA/4.2 mA // 10 mA/4 mA	4.3 mA/1.6 mA // 4.4 mA/1.6 mA	4 mA/1.6 mA	

Ordering data Complete module

Screw connection	Type	12/24VDC 1A1R	24/48VUC 1A1R	115VUC/230VAC 1A1R	
Order No.		8418270000	8418280000	8418290000	
Tension clamp connection	Type				
Order No.					

Ordering data Spare relay, pluggable

Type	12/24VDC 1A1R	24/48VUC 1A1R	115VUC/230VAC 1A1R	
Order No.				

Information

Articles with coloured order number are kept permanently in stock at the central warehouse in Germany. Delivery times see page X.2

K

WAVESERIES

2 change-over contacts

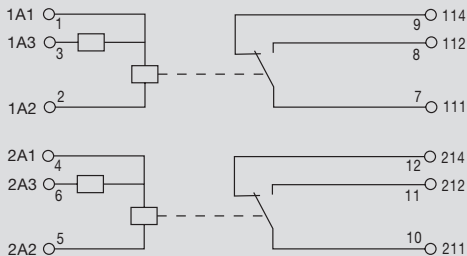
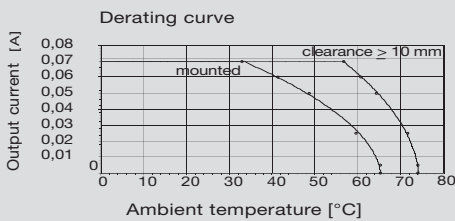

Output	
Max. switching voltage AC/Continuous current	250V/5A
Min. switching power	100mA/5Vdc
Response time / Release time	6ms/10ms
Contact base material	Ag alloy
Mechanical endurance	20x10 ⁶ switching cycles
Max. switching frequency at rated load	0.1Hz
Rated data	
Status indicator/Free wheel diode/Reverse volt. prot.	LED green/Yes/available
Ambient temp., fitted w. distance	-25 °C...+50 °C
Storage temperature	-40 °C...+60 °C
Climate	40°C/93% rel. humidity without condensation
Approvals	UL / CSA
Insulation coordinates (EN 50 178)	
Standards	EN 50178
Rated voltage	300 V
Impulse withstand voltage	6 kV (1.2/50 μ)
Creepage and clearance path input - output	=>5.5mm
Overvoltage category	III
Pollution severity	2
Secure separation acc. to VDE 0106 Part 101	Yes

Dimensions	Screw connection	Tension clamp connection
Clamping range (rating- / min. / max.)	mm ² 1.5 / 0.5 / 2.5	
Length x width x height	mm 92.4 / 22.5 / 112.4	

Information

Ordering data

Input

Rated voltage	12 Vdc // 24 Vdc, +/- 10 %
Rated current AC	
Rated current DC	approx. 23mA
Power rating	0.26W // 0.53W
Oper.-/drop-out volt. AC-coil	
Oper.-/drop-out volt. DC-coil	8.5 V / 3 V // 15 V/4.8 V
Pull-in curr./release curr. AC-coil	
Pull-in curr./release curr. DC-coil	15.2 mA/5.7 mA // 15.3 mA/5.6 mA

12/24VDC 2CO

24/48VUC 2CO

Rated voltage	24 Vuc // 48 Vuc, +/- 10 %
Rated current AC	approx. 15mA
Rated current DC	14 mA
Power rating	0.35VA(W) // 0.7VA(W)
Oper.-/drop-out volt. AC-coil	
Oper.-/drop-out volt. DC-coil	16V/9.5V // 29V/15V
Pull-in curr./release curr. AC-coil	9 mA/4.5 mA // 8.3mA/4.1mA
Pull-in curr./release curr. DC-coil	9 mA/4.5 mA // 8.3mA/4.1mA

24VUC/230VAC 2CO

Rated voltage	24 Vuc // 230 Vac, +/- 10 %
Rated current AC	approx. 15mA
Rated current DC	14mA (24Vdc)
Power rating	0.35W // 3.45VA
Oper.-/drop-out volt. AC-coil	13 V/9 V // 115 V/66 V
Oper.-/drop-out volt. DC-coil	13 V/9 V (24Vdc)
Pull-in curr./release curr. AC-coil	7.5 mA/4.7 mA // 7.4 mA/4.3 mA
Pull-in curr./release curr. DC-coil	7.5 mA/4.7 mA

Ordering data

Complete module

Screw connection	Type	WRS2 12/24VDC 2U
	Order No.	841830000
Tension clamp connection	Type	
	Order No.	

WRS2 24/48VUC 2U
841831000

WRS2 24VUC/230VAC 2U
841832000

Ordering data

Spare relay, pluggable

Type	
Order No.	

Information

WAVESERIES

3 NO contacts

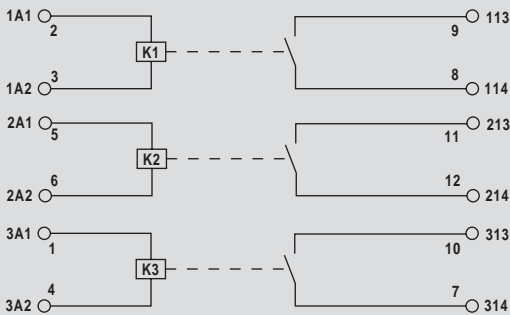
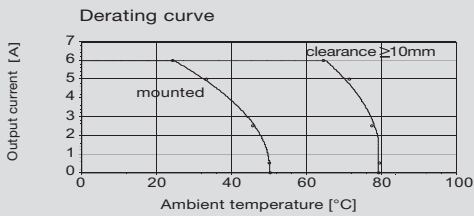

Output	
Max. switching voltage AC/Continuous current	250V/4A
Min. switching power	12V/10mA
Response time / Release time	5ms/21ms
Contact base material	AgSnO2
Mechanical endurance	20x10^6 switching cycles
Max. switching frequency at rated load	0.1Hz
Rated data	
Status indicator/Free wheel diode/Reverse volt. prot.	LED green/No/hot available
Ambient temp., fitted w. distance	-25 °C...+50 °C
Storage temperature	-40 °C...+60 °C
Climate	40°C/93% rel. humidity without condensation
Approvals	UL / CSA
Insulation coordinates (EN 50 178)	
Standards	EN 50178
Rated voltage	300 V
Impulse withstand voltage	6 kV (1.2/50 µ)
Creepage and clearance path input - output	=>5.5mm
Overvoltage category	III
Pollution severity	2
Secure separation acc. to VDE 0106 Part 101	Yes

Dimensions	Screw connection	Tension clamp connection
Clamping range (rating- / min. / max.)	mm²	1.5 / 0.5 / 2.5
Length x width x height	mm	92.4 / 22.5 / 112.4

Information

Ordering data

Input	24VUC 3A	230VAC 3A		
Rated voltage	24 Vuc +/- 10 %	230 Vac +/- 10 %		
Rated current AC	10.4mA	10.3mA		
Rated current DC	10.5mA			
Power rating	0.3VA // 0.25W	2.4VA		
Oper.-/drop-out volt. AC-coil	12.8 V / 5 V	207V/207V/207V		
Oper.-/drop-out volt. DC-coil	12.8 V / 5 V			
Pull-in curr./release curr. AC-coil	6.6 mA / 2.1 mA	9mA		
Pull-in curr./release curr. DC-coil	6.5 mA / 1.4 mA			

Ordering data Complete module

Screw connection	Type	WRS2 24VUC 3A	WRS2 230VAC 3A		
Order No.		8418330000	8418340000		
Tension clamp connection	Type				
Order No.					

Ordering data Spare relay, pluggable

Type				
Order No.				

Information

--	--	--	--	--

RS-SERIES / RS 30

1 NCC, 1 NOC
or 1 change-over contact

RS 30

Screw connection

1 NOC
1 NCC

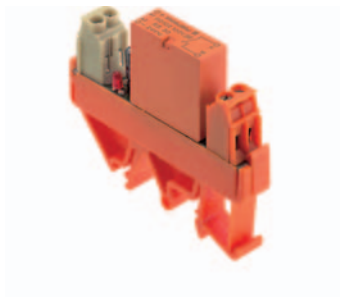

1 change-over contact



RS 30

Isolating plug with screw connection

1 NOC
1 NCC



1 change-over contact

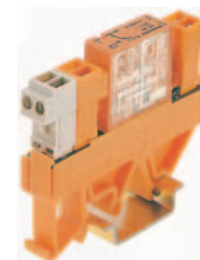

Technical data

Input voltage 5...60 V ± 10 %; 115 V/230 V + 5 % - 15%

Nominal consumption - (W)
Nominal consumption ~ (VA)
Release current of relay (at 20°C)
Release current of relay (at 20°C)
Pick-up current
Output voltage max.
Continuous current

5 VTTL	12 V~	24 V~	24 V≅	48 V~	48 V≅	60 V~	115 V~	115 V~	230 V~ ²⁾	240 V~
0.45 W ¹⁾	0.45 W	0.45 W	0.45 W	0.45 W	0.45 W	0.45 W	-	0.82 W	-	-
-	-	-	0.7 VA	-	0.6 VA	-	0.8 VA	-	0.8 VA	1.2 VA
-	3 mA	3 mA	2.5 mA~	2 mA	2.5 mA~	1 mA~	-	2 mA~	-	0.5 mA~
-	-	-	3.5 mA~	-	4.5 mA~	-	1 mA~	-	1 mA~	1 mA~
-	-	12 mA	-	10 mA	-	-	6 mA	4.3 mA	-	-
250 V	250 V	250 V	250 V	250 V	250 V	250 V	250 V	250 V	250 V	250 V
5 A	6 A	6 A	6 A	6 A	5 A	5 A	5 A	5 A	3 A	3 A

Derating curve
a = arranged on mounting rail in horizontal row without spacing
b = arranged on mounting rail in horizontal row with 20 mm spacing



Constant current

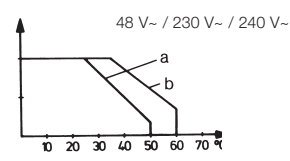
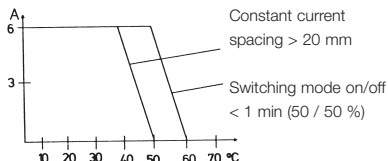

Switch-on current
Switch-on power under ohmic load
Min. switching power/switching current
Duration of bounce
Typical switching times
- , Pick-up delay
- , Release delay
Max. switching frequency
Contact material
Service life, mechanical
- , 24 V-, 1A ohmic load
- , 230 V-, 3A, ohmic load
Storage temperature
Ambient temperature, arranged on mounting rail
- , in horizontal row without spacing
- , in horizontal row with > 20 mm spacing

8 A
2000 VA / 100 W
250 mW / 10 mA
≤ 3 ms
≤ 8 ms
≤ 8 ms
≤ 8 ms
≤ 8 ms
≤ 12 ms
≤ 13 ms
≤ 12 ms
≤ 9 ms
≤ 12 ms
≤ 10 ms
≤ 10 ms
≤ 7 ms
≤ 7 ms
≤ 7 ms
≤ 16 ms
≤ 11 ms
≤ 12 ms
≤ 11 ms
≤ 8 ms
≤ 11 ms
≤ 9 ms
≤ 9 ms
70 Hz
70 Hz
70 Hz
30 Hz
70 Hz
20 Hz
70 Hz
30 Hz
70 Hz
30 Hz
30 Hz
30 Hz
AgNi, gold-flashed
>10 ⁷ switching cycles
> 5 x 10 ⁵ switching cycles
>7 x 10 ⁵ switching cycles
-40 °C...+60 °C
-25 °C...+40 °C
-25 °C...+50 °C

Insulation coordination acc. to EN 50 178

Overvoltage category
Pollution severity

III
2

Dimensions

Mounting width
Length (at right angles to mounting rail)
Height (with TS 32 / TS 35 x 7.5)

11.2 mm NOC / NCC, 25 mm change-over contact
70 mm (74 mm BL/SL version)
56 mm / 51.5 mm

¹⁾ Rated consumption of auxiliary voltage 24 V-.
²⁾ 230 V- on request

RS 30

Screw connection

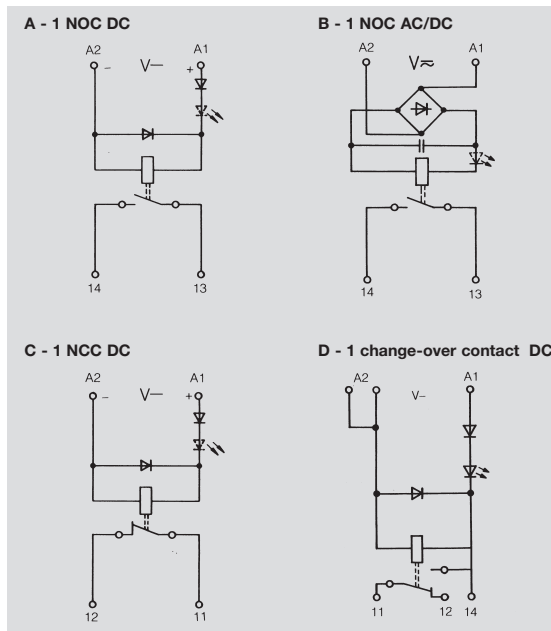

RS 30

Isolating plug with screw connection

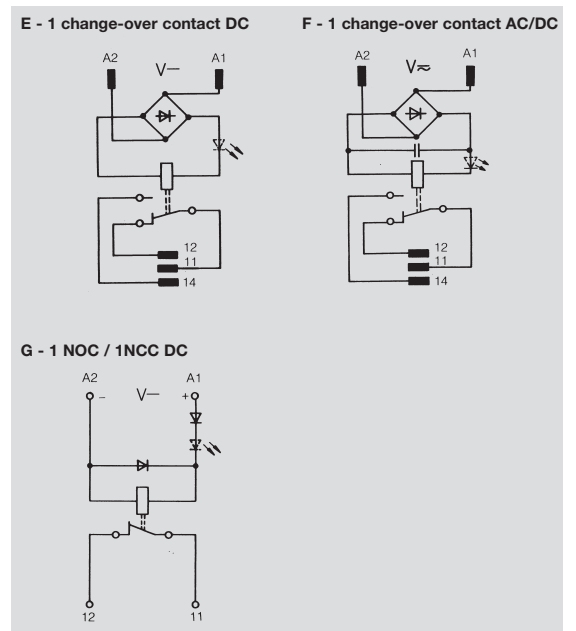

Order data

Mail-line wiring diagram		A	B	C	D	E	F	G	G
Input voltage	Function display	NOC	NOC	NCC	change-over contact	change-over contact	change-over contact	NOC	NCC
5 V-, TTL	without							1167760000	1167660000
12 V-	without LED red	1129421001		1129521001		1129660000			
24 V-	without LED green LED red	1101661001 1101611001 1101621001		1100961001 1100911001 1100921001	1181511001 1181521001	1100260000 1100210000 1100220000			
24 V≈	without LED green LED red		1101761001 1101711001 1101721001				1100360000		
48 V-	LED green LED red	1101811001 1101821001				1100410000 1100420000			
48 V≈	without LED green		1101911001				1100560000		
60 V-	without LED green LED red	1102061001 1102011001				1100620000			
115 V-	without LED green LED red	1155161001 1155111001 1155121001		1155261001 1155211001 1155221001					
115 V-	without LED green LED red		1102161001 1102111001 1102121001				1100760000		
230 V-	without LED green LED red		1102261001 1102211001 1102221001				1100860000		
240 V-	without LED green LED red		1128561001 1128511001 1128521001						

Articles with coloured order number are kept permanently in stock at the central warehouse in Germany. Delivery times see page X.2

RS-SERIES - RS 31

1 change-over contact

- For high switching power
- Suitable to switch inductive loads

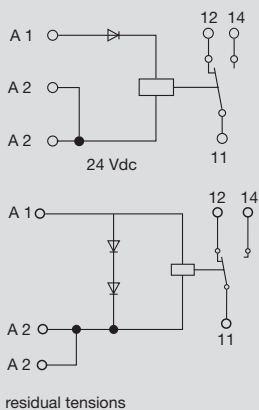
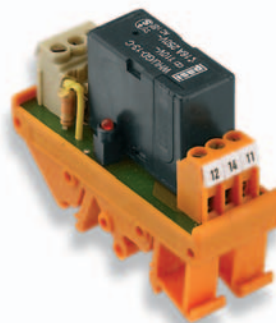

Output	
Max. switching voltage AC/Continuous current	250V/16A
Min. switching power	1W
Response time / Release time	9ms/10ms
Contact base material	AgCdO
Mechanical endurance	3x10 ⁷ switching cycles
Max. switching frequency at rated load	0.1Hz
Rated data	
Status indicator/Free wheel diode/Reverse volt. prot.	LED green/Yes/available
Ambient temp., fitted w. distance	-25 °C...+40 °C
Storage temperature	-40 °C...+60 °C
Climate	40°C/93% rel. humidity without condensation
Approvals	CE
Insulation coordinates (EN 50 178)	
Standards	EN 50178
Rated voltage	250V
Impulse withstand voltage	6 kV
Creepage and clearance path input - output	3mm
Overvoltage category	III
Pollution severity	2
Secure separation acc. to VDE 0106 Part 101	No

Dimensions	Screw connection	Tension clamp connection
Clamping range (rating- / min. / max.)	mm ²	2.5 / 0.5 / 4
Length x width x height	mm	70.0 / 25.0 / 58.0

Information

Applications

Derating curve

K

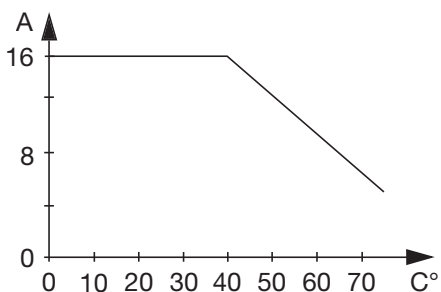

RS-SERIES - RS 31

1 change-over contact

Ordering data	24VDC 1CO	48VDC 1CO	115V DC 1CO	115VAC 1CO
Input				
Rated voltage	24 Vdc +/- 10 %	48 Vdc +/- 10 %	115 Vdc + 5 / - 15%	115 Vac +5 %/ -15 %
Rated current AC				8mA
Rated current DC	40mA	20mA	8mA	
Power rating	1W	1W	1W	1VA
Oper.-/drop-out volt. AC-coil				98V
Oper.-/drop-out volt. DC-coil	21.5V	43V	98V	
Pull-in curr./release curr. AC-coil				-/1.5mA
Pull-in curr./release curr. DC-coil	-/11.5mA	-/13.5mA	-/5.5mA	
Ordering data Complete module				
Screw connection Type	RS 31 24VDC LD LP 1U	RS 31 48VDC LD 1U LP	RS 31 115VDC LD LP 1U	RS 31 115VAC LD LP 1U
Order No.	1128311001	1150761001	1150361001	1150461001
Tension clamp connection Type				
Order No.				
Ordering data Spare relay, pluggable				
Type				
Order No.				
Information				
Ordering data	230VAC 1CO			
Input				
Rated voltage	230 Vac + 5 / - 15%			
Rated current AC	4.5mA			
Rated current DC				
Power rating	1VA			
Oper.-/drop-out volt. AC-coil	195V			
Oper.-/drop-out volt. DC-coil				
Pull-in curr./release curr. AC-coil	-/2.2mA			
Pull-in curr./release curr. DC-coil				
Ordering data Complete module				
Screw connection Type	RS 31 230VAC LD LP 1U			
Order No.	1128461001			
Tension clamp connection Type				
Order No.				
Ordering data Spare relay, pluggable				
Type				
Order No.				
Information				

Articles with coloured order number are kept permanently in stock at the central warehouse in Germany. Delivery times see page X.2

RS-SERIES - RS 32

2 change-over contacts, DC input

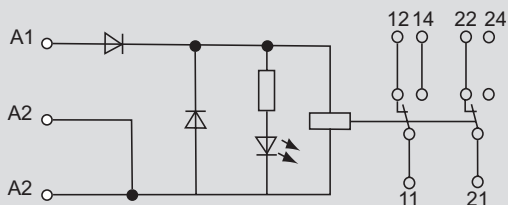
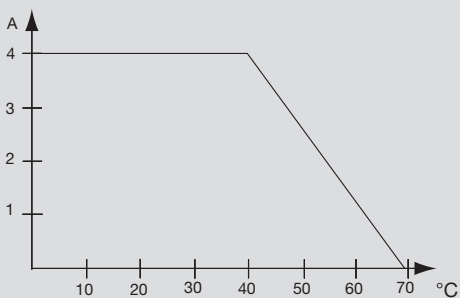
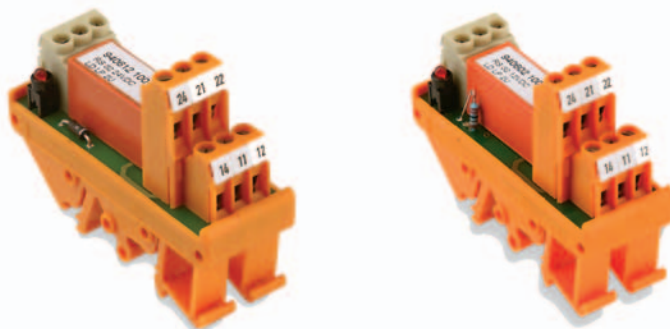

Output	
Max. switching voltage AC/Continuous current	250V/4A
Min. switching power	10V/100mA
Response time / Release time	13ms/10ms
Contact base material	AgNi 0.15 gold flashed
Mechanical endurance	>30x10 ⁶ switching cycles
Max. switching frequency at rated load	0.1Hz
Rated data	
Status indicator/Free wheel diode/Reverse volt. prot.	LED red/No/available
Ambient temp., fitted w. distance	-25 °C...+40 °C
Storage temperature	-40 °C...+60 °C
Climate	40°C/93% rel. humidity without condensation
Approvals	CE
Insulation coordinates (EN 50 178)	
Standards	EN 50178
Rated voltage	250V
Impulse withstand voltage	4 kV
Creepage and clearance path input - output	3mm
Overvoltage category	III
Pollution severity	2
Secure separation acc. to VDE 0106 Part 101	No
Dimensions	
Clamping range (rating- / min. / max.)	mm ² 2.5 / 0.5 / 4
Length x width x height	mm 70.0 / 25.0 / 68.0
Information	

Ordering data

Input	12VDC 2CO	24VDC 2CO	48VDC 2CO	60VDC 2CO
Rated voltage	12 Vdc +/- 10 %	24 Vdc +/- 10 %	48 Vdc +/- 10 %	60 Vdc +/- 10 %
Rated current AC				
Rated current DC	50mA	25mAdc	12mAdc	10mAdc
Power rating	0.6W	0.6W	0.6W	0.6W
Oper.-/drop-out volt. AC-coil				
Oper.-/drop-out volt. DC-coil	11V	21.5V	43V	54V
Pull-in curr./release curr. AC-coil				
Pull-in curr./release curr. DC-coil	-/9.5mA	-/5mA	-/2mA	-/1.5mA

Ordering data Complete module

Screw connection	Type	RS 32 12VDC LD LP 2U	RS 32 24VDC LD LP 2U	RS 32 48VDC LD LP 2U	RS 32 60VDC LD LP 2U
Order No.		9406021001	9406121001	9406321001	9406521001
Tension clamp connection	Type				
Order No.					

Ordering data Spare relay, pluggable

Type	Order No.

Information

--	--	--	--

K

RS-SERIES - RS 32

2 change over contacts, UC input

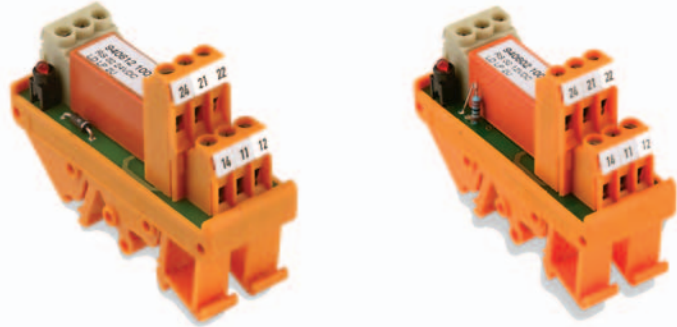

Relay coupler

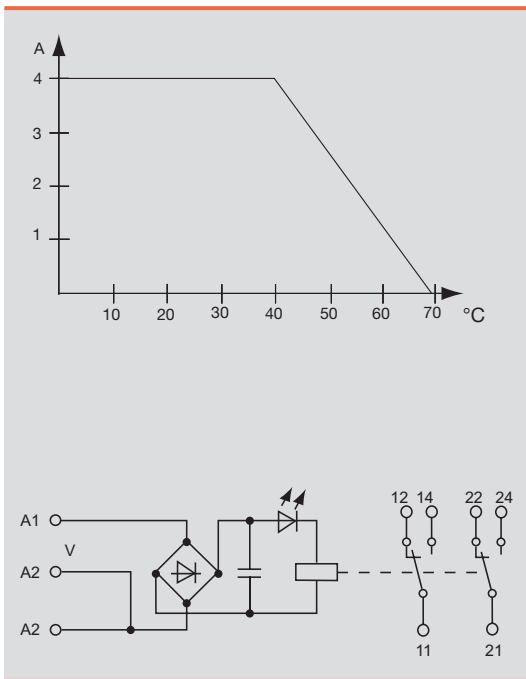

Output	
Max. switching voltage AC/Continuous current	250V/4A
Min. switching power	10V/100mA
Response time / Release time	13ms/10ms
Contact base material	AgNi 0.15 gold flashed
Mechanical endurance	>30x10 ⁶ switching cycles
Max. switching frequency at rated load	0.1Hz
Rated data	
Status indicator/Free wheel diode/Reverse volt. prot.	LED red/No/not available
Ambient temp., fitted w. distance	-25 °C...+40 °C
Storage temperature	-40 °C...+60 °C
Climate	40°C/93% rel. humidity without condensation
Approvals	CE
Insulation coordinates (EN 50 178)	
Standards	EN 50178
Rated voltage	250V
Impulse withstand voltage	4 kV
Creepage and clearance path input - output	3mm
Overtoltage category	III
Pollution severity	2
Secure separation acc. to VDE 0106 Part 101	No

Dimensions	Screw connection	Tension clamp connection
Clamping range (rating- / min. / max.)	mm ² 2.5 / 0.5 / 4	
Length x width x height	mm 70.0 / 25.0 / 68.0	

Information

Ordering data

Input	24VUC 2CO	48VUC 2CO	115VUC 2CO	230VUC 2CO
Rated voltage	24 Vuc +/- 10 %	48 Vuc +/- 10 %	115 Vuc + 5 / - 15%	230 Vuc + 5 / - 15%
Rated current AC	28mAac	18mAac	5mA	4.3mA
Rated current DC	18mAdc	12mAdc	5 mA	4.3mA
Power rating	0.6W // 0.9VA	0.6W // 0.9VA	0.5W // 0.6VA	1W //1VA
Oper.-/drop-out volt. AC-coil				
Oper.-/drop-out volt. DC-coil	21.5V	43V	98V	195V
Pull-in curr./release curr. AC-coil	-/2.5mA	-/4.5mA	-/1.5mA	-/2mA
Pull-in curr./release curr. DC-coil	-/4.5mA	-/2mA	-/1mA	-/1.2mA

Ordering data Complete module

Screw connection	Type	24VUC 2CO	48VUC 2CO	115VUC 2CO	230VUC 2CO
Type		RS 32 24VUC LD LP 2U	RS 32 48VUC LD LP 2U	RS 32 115VUC LD LP 2U	RS 32 230VUC LD LP 2U
Order No.		9406221001	9406421001	9406621001	9406721001
Tension clamp connection	Type				
Type					
Order No.					

Ordering data Spare relay, pluggable

Type	24VUC 2CO	48VUC 2CO	115VUC 2CO	230VUC 2CO
Type				
Order No.				

Information

--	--	--	--	--

Articles with coloured order number are kept permanently in stock at the central warehouse in Germany. Delivery times see page X.2

K

RS-SERIES - RS 32

2 change over contacts, multiple voltage input

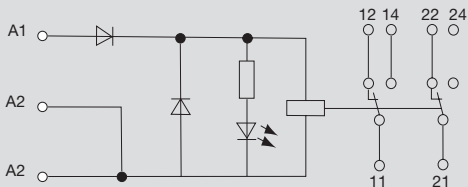
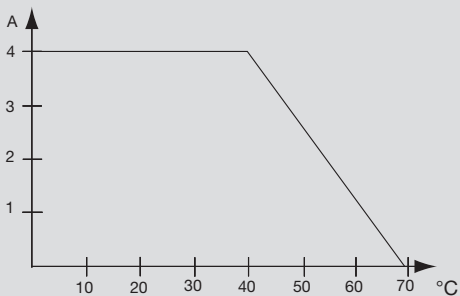
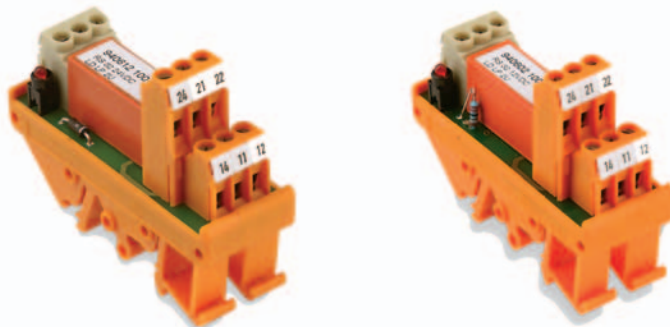

Output	
Max. switching voltage AC/Continuous current	250V/4A
Min. switching power	10V/100mA
Response time / Release time	13ms/10ms
Contact base material	AgNi 0.15 gold flashed
Mechanical endurance	>30x10 ⁶ switching cycles
Max. switching frequency at rated load	0.1Hz
Rated data	
Status indicator/Free wheel diode/Reverse volt. prot.	LED red/No/not available
Ambient temp., fitted w. distance	-25 °C...+40 °C
Storage temperature	-40 °C...+60 °C
Climate	40°C/93% rel. humidity without condensation
Approvals	CE
Insulation coordinates (EN 50 178)	
Standards	EN 50178
Rated voltage	250V
Impulse withstand voltage	4 kV
Creepage and clearance path input - output	3mm
Overvoltage category	III
Pollution severity	2
Secure separation acc. to VDE 0106 Part 101	No

Dimensions	Screw connection	Tension clamp connection
Clamping range (rating- / min. / max.)	mm ² 2.5 / 0.5 / 4	
Length x width x height	mm 70.0 / 25.0 / 68.0	

Information

Ordering data

Input

	24-48VUC 2CO	115-230VUC 2CO
Rated voltage	24 Vuc // 48 Vuc +/- 10 %	115 Vuc // 230 Vuc + 5 / - 15%
Rated current AC	28mA / 22mA	5.6mA/5.3mA
Rated current DC	18mA / 20mA	5.4mA/5mA
Power rating	0.6W // 0.9VA	1W // 1VA
Oper.-/drop-out volt. AC-coil		
Oper.-/drop-out volt. DC-coil	21.5V/43V	98V/195V
Pull-in curr./release curr. AC-coil	-/3mA // -/4.5mA	-/1.5mA // -/2mA
Pull-in curr./release curr. DC-coil	-/5mA // -/2mA	-/1mA // -/1.2mA

Ordering data

Complete module

Screw connection	Type	24-48VUC 2CO	115-230VUC 2CO
	Type	RS 32 24-48VUC LD LP 2U	RS 32 115-230VUC LD 2U
	Order No.	1122661001	1122761001
Tension clamp connection	Type		
	Order No.		

Ordering data

Spare relay, pluggable

	Type	24-48VUC 2CO	115-230VUC 2CO
	Type		
	Order No.		

Information

K

RS-SERIES – with RSM multiple interface

with one change-over contact each

- LEDs red, other colours on request
- Mounting feet can also be mounted turned at an angle of 180°

RSM 4 R / RSM 4 RS

4 relays
soldered or plugged

RSM 8 R / RSM 8 RS

8 relays
soldered or plugged

RSM 16 R / RSM 16 RS

16 relays
soldered or plugged

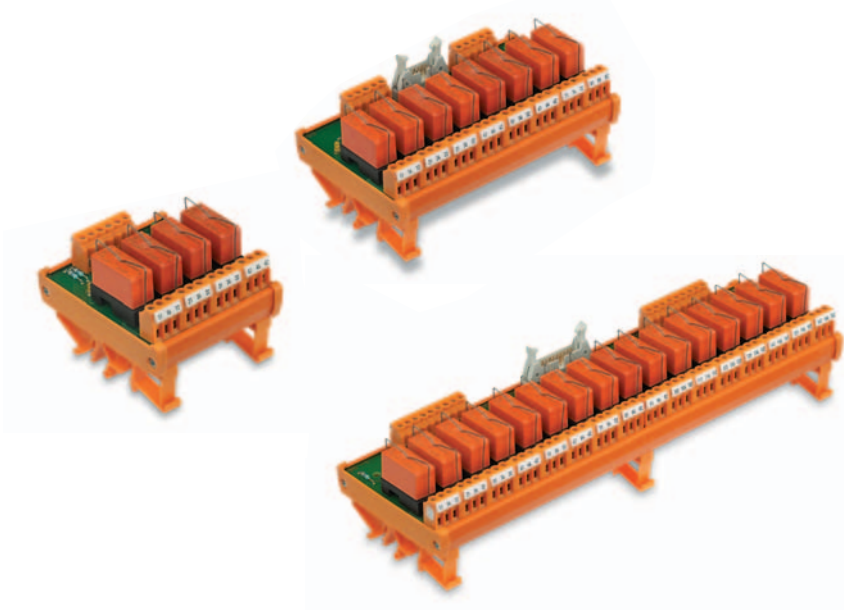

Technical data

Rated data	
Input voltage	
Nominal consumption	soldered relay
	plugged relay
Nominal consumption	soldered relay
	plugged relay
Pull-in current	soldered relay
	plugged relay
Pull-in current	soldered relay
	plugged relay

24 Vdc	24 Vac/dc	48 Vdc	115 Vac/dc	230 Vac
0.45 W	–	–	–	–
0.75 W	0.45 W	0.75 W	–	–
–	–	–	–	–
–	0.7 VA	–	0.6 VA	1.2 VA
12 mA	–	–	–	–
23 mA	12 mA	14 mA	5 mA	–
–	–	–	–	–
–	16.5 mA	–	6 mA	4 mA
2 mA	–	1.5 mA	–	1 mA
250 V	250 V	250 V	250 V	250 V
6 A	6 A	6 A	6 A	3 A

Release current of relay (at 20°C)

Output voltage max.

Continuous current

Derating curve

a = arranged on mounting rail in horizontal row without spacing

b = arranged on mounting rail in horizontal row

with 20 mm spacing

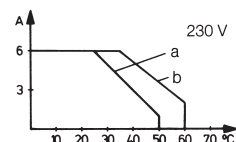
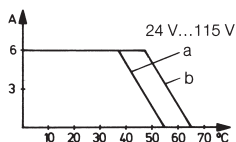

Typical switch-on times

Pick-up delay (ac / dc)

Release delay (ac / dc)

≤ 8 ms	≤ 10 ms / 10 ms	≤ 12 ms	≤ 8 ms / 10 ms	≤ 10 ms
≤ 7 ms	≤ 15 ms / 20 ms	≤ 11 ms	≤ 5 ms / 8 ms	≤ 10 ms

Duration of bounce

Switch-on current

Switch-on power under ohmic load

Min. switching power / switching current

Contact material

Service life

24 Vdc, 1A, ohmic load

230 Vac, 3A, ohmic load

Storage temperature

Ambient temperature

Insulation coordination acc. to EN 50 178

Overvoltage category

Pollution severity

Dimensions

Conductor cross-sectional area (screw connection)

≤ 3 ms
8 A
2000 VA
250 mW/10 mA
AgNi 90/10, AgNi0,15, gold-flashed
> 30 x 10 ⁶ switching cycles
> 5 x 10 ⁵ switching cycles
> 7 x 10 ⁵ switching cycles
–40°C...+60°C
–25°C...+50°C
III
2
0.5...2.5 mm ²

RS-SERIES – with RSM multiple interface

DC/AC/AC voltage

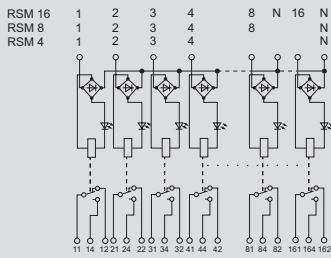

DC voltage, switching minus (negative-switching)

joint plus potential,
minus connected up

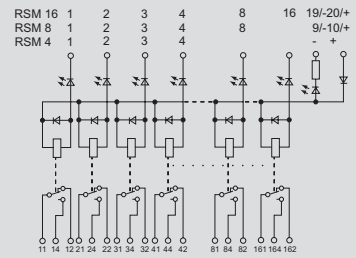

DC voltage, positive-switching

joint minus potential,
plus connected up

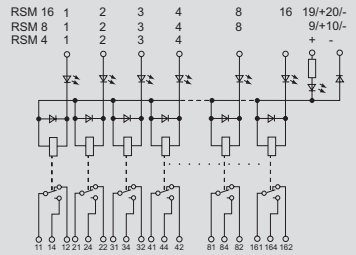

Order data

Connection technology	
Input	Flat band connection Multiple plug with locking acc. to DIN 41651/part 1 and 2
Output	Screw connection
Input	Screw connection <ul style="list-style-type: none"> Plugged relay Screw connection and multiple plug acc. to IEC 603-1/DIN 41651 Relay soldered
Output	Screw connection Multiple plug acc. to IEC 603-1/DIN 41651

Input voltage		4 relays	8 relays	16 relays
		RSM 4 R/RS (B = 75 mm)	RSM 8 R/RS (B = 145 mm)	RSM 16 R/RS (B = 285 mm)
24 Vdc, switching minus	Relay soldered		1100061001	1100161001
	Relay pluggable	1113361001¹⁾	1113561001¹⁾	1113761001¹⁾
24 Vdc, switching plus	Relay soldered	1112361001	1107761001	1107861001
	Relay pluggable	1113461001¹⁾	1113661001¹⁾	1113861001¹⁾
24 Vdc, switching minus	Relay soldered		1112661001	
	Relay pluggable	1173461001	1173561001	1173661001
24 Vac/dc	Relay pluggable	1113961001	1114161001	1114361001
48 Vdc, switching plus	Relay pluggable	1114561001	1114661001	1114761001
115 Vac/dc	Relay pluggable	1114861001	1114961001	1115061001
230 Vac	Relay pluggable			

¹⁾ approved by Germanisch Lloyd

Spare relays (for plugging)

For RSM ... R/RS, 24 V	Input voltage	Contact material	Remarks	Order no.
	24 Vdc	AgNi 90/10	RT 314024 with clip	8630780000
		AgNi 90/10	RT 314024 without clip	4058480000
For RSM ... R/RS, 48 V	48 Vdc	AgNi 90/10	RT 314048 with clip	8630790000
		AgNi 90/10	RT 314048 without clip	4058740000
For RSM ... R/RS, 115 V and 230 V	115 Vdc	AgNi 90/10	RT 314110 with clip	8630770000
		AgNi 90/10	RT 314110 without clip	4058500000

Articles with coloured order number are kept permanently in stock at the central warehouse in Germany. Delivery times see page X.2

MCZ-Series

MiniConditioner MCZ R

Module can be used as an universal interface between control and actuator for switching small and medium loads

- The pluggable cross-connection in input and output minimizes the effort to wire
- Width 6 mm, low height

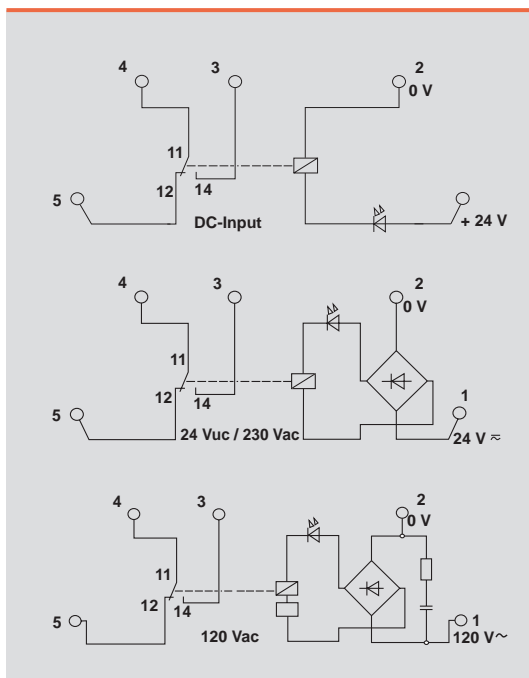

Output	
Max. switching voltage AC/Continuous current	400V/6A
Min. switching power	12V/100mA
Response time / Release time	4.5ms/10ms
Contact base material	AgSnO2
Mechanical endurance	20x10^6 switching cycles
Max. switching frequency at rated load	0.1Hz
Rated data	
Status indicator/Free wheel diode/Reverse volt. prot.	LED green/Yes/available
Ambient temp., fitted w. distance	-25 °C...+50 °C
Storage temperature	-40 °C...+60 °C
Climate	40°C/93% rel. humidity without condensation
Approvals	CE, UL, CSA, GL
Insulation coordinates (EN 50 178)	
Standards	EN 50178
Rated voltage	300 V
Impulse withstand voltage	6 kV
Creepage and clearance path input - output	=> 5.5mm
Overtoltage category	III
Pollution severity	2
Secure separation acc. to VDE 0106 Part 101	Yes

Dimensions	Screw connection	Tension clamp connection
Clamping range (rating- / min. / max.)	mm²	1.5 / 0.5 / 2.5
Length x width x height	mm	91.0 / 6.0 / 63.2

Information

Applications

Limit diagram

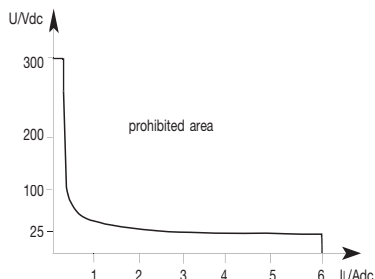

Derating curve

— rowed without clearances on the mounting rail
 - - - - rowed with 20 mm spacing on the mounting rail

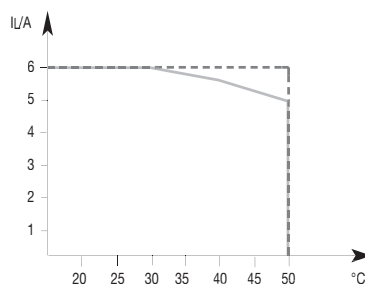

K

MCZ-Series

MiniConditioner MCZ R

Ordering data	24VDC 1CO	24VUC 1CO	24VDC 1CO AU	60VDC 1CO
Input				
Rated voltage	24 Vdc +/- 20 %	24 Vuc +/- 10 %	24 Vdc +/- 20 %	60 Vdc +/- 20 %
Rated current AC		10.8mA		
Rated current DC	6.3mA	6.1mA	6.3mA	3mA
Power rating	156mW	160mVA / 150mW	156mW	180mW
Oper./drop-out volt. AC-coil		approx.17V/approx.7V		
Oper./drop-out volt. DC-coil	12V...19V/4V...5.5V	approx.19V/approx.4V	12V...19V/4V...5.5V	approx.38V/approx.14V
Pull-in curr./release curr. AC-coil				
Pull-in curr./release curr. DC-coil	5.7mA	9mA/5mA	5.7mA	2.7mA
Ordering data Complete module				
Screw connection Type				
Order No.				
Tension clamp connection Type				
Order No.	MCZ R 24VDC 8365980000	MCZ R 24VUC 8390590000	MCZ R 24VDC 8442960000	MCZ R 60VDC 8470380000
Ordering data Spare relay, pluggable				
Type				
Order No.				
Information				
Ordering data				
Input				
Rated voltage	110 Vdc +/- 10 %	120 Vac -15 %/ +10 %	230 Vac +/- 10 %	
Rated current AC		7mA	9.5mA	
Rated current DC	2.85mA			
Power rating	340mW	0.85VA	2.1VA	
Oper./drop-out volt. AC-coil		approx.7V/approx.22V	approx.115V/approx.60V	
Oper./drop-out volt. DC-coil	approx.68V/approx.19V			
Pull-in curr./release curr. AC-coil		4mA/1.3mA	5mA/2.5mA	
Pull-in curr./release curr. DC-coil	1.6mA/0.4mA			
Ordering data Complete module				
Screw connection Type				
Order No.				
Tension clamp connection Type				
Order No.	MCZ R 110VDC 8467470000	MCZ R 120VAC 8420880000	MCZ R 230VAC 8237710000	
Ordering data Spare relay, pluggable				
Type				
Order No.				
Information				

Articles with coloured order number are kept permanently in stock at the central warehouse in Germany.
Delivery times see page X.2

DK-SERIES

1 NO contact, input bottom

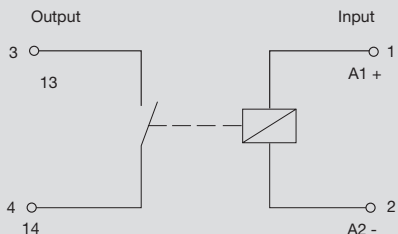
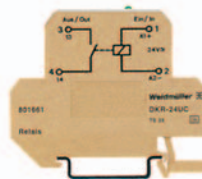

Output	
Max. switching voltage AC/Continuous current	100V/500mA
Min. switching power	1 V / 1 mA
Response time / Release time	typ.0.7...2.5ms/0.2...2ms
Contact base material	RH/RU
Mechanical endurance	10 ⁹ switching cycles
Max. switching frequency at rated load	200Hz
Rated data	
Status indicator/Free wheel diode/Reverse volt. prot.	LED green/Yes/available
Ambient temp., fitted w. distance	-25 °C...+40 °C
Storage temperature	-40 °C...+60 °C
Climate	40°C/93% rel. humidity without condensation
Approvals	CE
Insulation coordinates (EN 50 178)	
Standards	EN 50178
Rated voltage	150 V
Impulse withstand voltage	1.5 kV
Creepage and clearance path input - output	=>3mm
Overvoltage category	III
Pollution severity	2
Secure separation acc. to VDE 0106 Part 101	No

Dimensions	Screw connection	Tension clamp connection
Clamping range (rating- / min. / max.)	mm ² 4 / 0.5 / 4	
Length x width x height	mm 77.0 / 6.0 / 62.0	
Information	AP DK4: 0687560000	

Ordering data

Input	5 VDC 1A	12VDC 1A	24VUC 1A	24VDC 1A
Rated voltage	5 Vdc +/- 5 %	12 Vdc +/- 10 %	12 Vuc +/- 10 %	24 Vdc +/- 20 %
Rated current AC			15mA	
Rated current DC	12.5mA	12mA	12mA	9.3mA
Power rating	65mW	144mW	144mW	225mW
Oper.-/drop-out volt. AC-coil			12V	
Oper.-/drop-out volt. DC-coil	4.4V	9V	11V	11V
Pull-in curr./release curr. AC-coil			6.3mA	
Pull-in curr./release curr. DC-coil	11.8mA	10mA	3.8mA	7.5mA

Ordering data				
For TS 32	Type	DKR 32 5VDC 1A	DKR 32 24VUC 1A	DKR 32 24VDC 1A
	Order No.	801960000	8008110000	8016620000
For TS 35	Type	DKR 35 5VDC 1A	DKR 35 12VDC 1A	DKR 35 24VDC 1A
	Order No.	8019610000	8171100000	8008170000

Ordering data				
	Type			
	Order No.			

Information				

K

DK-SERIES

1 NO contact, input top

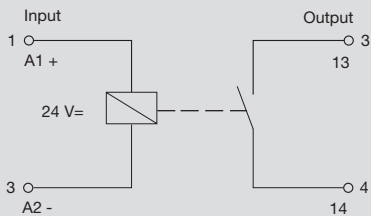
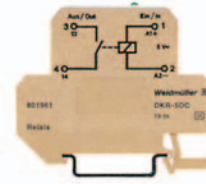

Output	
Max. switching voltage AC/Continuous current	100V/500
Min. switching power	1 V / 1 mA
Response time / Release time	typ.0.7...2.5ms/0.2...2ms
Contact base material	RH/RU
Mechanical endurance	10 ⁴ switching cycles
Max. switching frequency at rated load	25Hz
Rated data	
Status indicator/Free wheel diode/Reverse volt. prot.	LED green/Yes/available
Ambient temp., fitted w. distance	-25 °C...+40 °C
Storage temperature	-40 °C...+60 °C
Climate	40°C/93% rel. humidity without condensation
Approvals	CE
Insulation coordinates (EN 50 178)	
Standards	EN 50178
Rated voltage	150 V
Impulse withstand voltage	1.5 kV
Creepage and clearance path input - output	=>3mm
Overvoltage category	III
Pollution severity	2
Secure separation acc. to VDE 0106 Part 101	No

Dimensions	Screw connection	Tension clamp connection
Clamping range (rating- / min. / max.)	mm ² 4 / 0.5 / 4	
Length x width x height	mm 77.0 / 6.0 / 62.0	
Information	AP DK4: 0687560000	

Ordering data

Input	24 VDC 1A
Rated voltage	24 Vdc +/- 20 %
Rated current AC	
Rated current DC	9.3mA
Power rating	225mW
Oper.-/drop-out volt. AC-coil	
Oper.-/drop-out volt. DC-coil	11V
Pull-in curr./release curr. AC-coil	
Pull-in curr./release curr. DC-coil	3.75mA

Ordering data

For TS 32	Type			
	Order No.			
For TS 35	Type	DKR 35 24VDC 1A		
	Order No.	8215620000		

Ordering data

	Type			
	Order No.			

Information

--	--	--	--	--

Articles with coloured order number are kept permanently in stock at the central warehouse in Germany. Delivery times see page X.2

DK-SERIES

1 change-over contact, input bottom

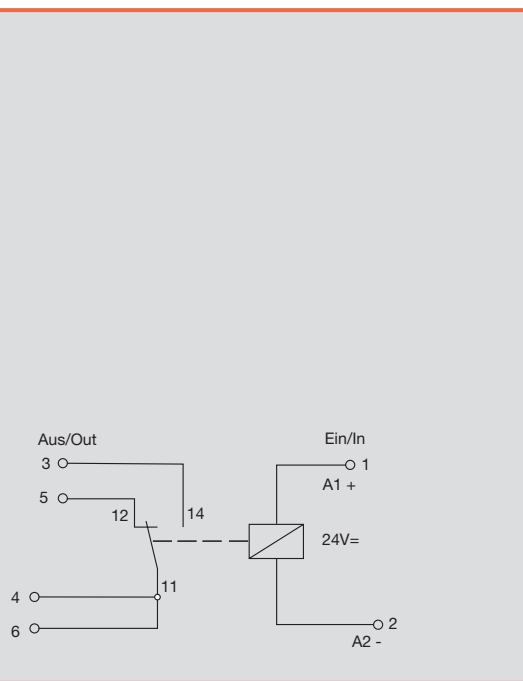
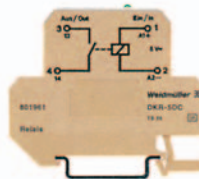

Output	
Max. switching voltage AC/Continuous current	250V/6A
Min. switching power	10 V / 100 mA
Response time / Release time	6ms/15ms ac;8ms dc
Contact base material	AgSnO2
Mechanical endurance	2x10 ⁷ switching cycles
Max. switching frequency at rated load	20
Rated data	
Status indicator/Free wheel diode/Reverse volt. prot.	LED green/Yes/not available
Ambient temp., fitted w. distance	-40°C...+60°C
Storage temperature	-40 °C...+60 °C
Climate	40°C/93% rel. humidity without condensation
Approvals	
Insulation coordinates (EN 50 178)	
Standards	EN 50178
Rated voltage	300 V
Impulse withstand voltage	4 kV
Creepage and clearance path input - output	=>8mm
Overtoltage category	III
Pollution severity	2
Secure separation acc. to VDE 0106 Part 101	No
Dimensions	
Clamping range (rating- / min. / max.)	mm ² 4 / 0.5 / 4
Length x width x height	mm 77.0 / 6.0 / 62.0
Information	
End plate	

Ordering data

Input	24VUC 1CO	24VDC 1CO	24VUC 1CO	
Rated voltage	24 Vuc +/- 20 %	24 Vdc +/- 20 %	24 Vuc +/- 20 %	
Rated current AC	9mA		20mA	
Rated current DC	7mA	11.5mA	16mA	
Power rating	220mVA/180mW	384mW	480mW /400mW	
Oper.-/drop-out volt. AC-coil	18V		18V	
Oper.-/drop-out volt. DC-coil	19V	19V	18V	
Pull-in curr./release curr. AC-coil	7mA		12.8mA	
Pull-in curr./release curr. DC-coil	5.5mA	9mA	11.5mA	

Ordering data

For TS 32	Type	DKR DK5 24VUC 1U			
	Order No.	9454910000			
For TS 35	Type	DKR DK5 24VUC 1U	DKR 35 24VDC 1U	DKR 35 24VUC 1U	
	Order No.	9454910000	8181980000	8181970000	

Ordering data

	Type				
	Order No.				

Information

--	--	--	--	--	--

EG SERIES

1 NCC, 1 NOC, 1 change-over contact

- Also with hard gold-plated contacts
- With combination foot for TS 32, TS 32 and TS 35 (clip-in base for plug-in) change-over contacts
- 10 mm wide
- Screw connection

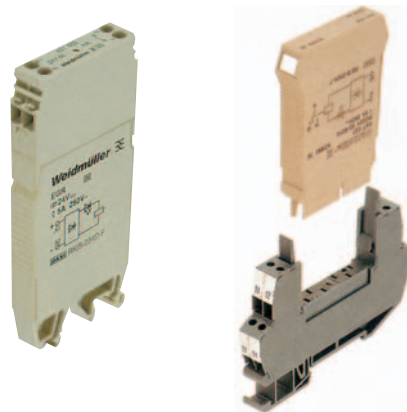

Main-line wiring diagram

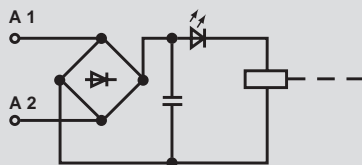

Main-line wiring diagram

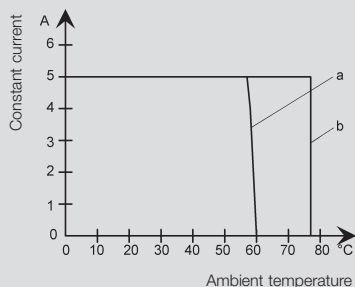

a = arranged on mounting rail in horizontal row without spacing

b = arranged on mounting rail in horizontal row with 20 mm spacing

Technical data

Output

Max. switching voltage AC / constant current	250 V / 5 A
Min. switching power	100 mW / 10 mA
hard gold-plated contacts	40 µW
Response time/release time	≤ 8 ms / ≤ 6 ms
Contact base material	AgNi 0.15 gold-flashed
hard gold-plated contacts	AgNi 0.15 / 5 µ Au
Mechanical service life	> 15 x 10 ⁶ switching cycles
Max. switching frequency at rated load	0,1 Hz

Nominal data

Status indicator/recovery diode	LED green / yes
Ambient temperature arranged in horizontal row with spacing	-25 °C ... +60 °C
Lagertemperatur	-40 °C ... +60 °C

Insulation coordination (EN 50 178)

Standards	EN 50178
Rated voltage	300 V
Rated impuls voltage	8 kV
Creepage and clearance path input-output	≥ 8 mm
Overvoltage category	III
Pollution severity	2
Protective separation acc. to VDE 0106 part 101	DIN VDE 0106

		1 NOC, 1 NCC	1 change-over contact
Clamping range (nom./min/max)	mm ²	1.5 x 0.5 x 1.5	1.5 x 0.5 x 1.5
Length x width x height	mm	44.0 x 10.0 x 96.0	95.0 x 10.0 x 93.0

Remarks

EG SERIES

1 NOC, 1 NCC, 1 change-over contact

Order data	12 Vac/dc	24 Vdc	24 Vac/dc	115Vac/dc
Input				
Rated voltage	12 Vac/dc, +15%, -10 %	24 Vdc +15 % -10 %	24 Vac/dc +15 % -10 %	115 Vac/dc + 15 % -10 %
Nominal power	320 mW +20% -10%	280 mW +20% -10%	280 mW +20% -10%	330 mW +15% -10%
Switch-on current, max.	120 mA	12 mA	240 mA	160 mA
Order data with combination foot				
1 NOC	EGR EG 7	EGR EG 7	EGR EG7	EGR EG7
Order no.	8092310000	8216520000	8092340000	8092430000
1 NCC	EGR EG 7	EGR EG 7	EGR EG7	EGR EG7
Order no.	8092320000	8216530000	8092350000	8092440000
Order data, pluggable (order clip-in base separately)				
1 change-over contact	RST EG 7	RST EG 7	RST EG 7	RST EG 7
Order no.	8216550000	8216570000	8216580000	8216610000
1 clip-in base	RS EG 7	RS EG 7	RS EG 7	RS EG 7
Order no.	8193830000	8193830000	8193830000	8193830000

Order data	230 Vac	Contacts hard gold-plated	24 Vdc	230 Vac
Input				
Rated voltage	230 Vac +15 % -10 %		24 Vdc +15% -10%	230 Vac +15% -10%
Nominal power	280 mW +15% -10%		280 mW +20% -10%	280 mW +15% -10%
Switch-on current, max.	185 mA		12 mA	185 mA
Order data with combination foot				
1 NOC	EGR EG 7		EGR EG 7	EGR EG 7
Order no.	8092460000		8147120000	8178200000
1 NCC	EGR EG 7		EGR EG 7	EGR EG 7
Order no.	8092470000		8147140000	
Order data, pluggable (order clip-in base separately)				
1 change-over contact	RST EG 7		RST EG 7	RST EG 7
Order no.	8216620000		8216560000	8216630000
1 clip-in base	RS EG 7		RS EG 7	RS EG 7
Order no.	8193830000		8193830000	8193830000



Articles with coloured order number are kept permanently in stock at the central warehouse in Germany. Delivery times see page X.2

Optocoupler – Overview

Owing to the increasing degree of automation, the separation of potential between control circuits (control side / field side) is becoming increasingly significant. The connection between the controller, which is the key component of every automated system, and the various sensors and actuators must be electrically safe and free of any feedback. Optocouplers are finding increasing use here. They provide the necessary degree of safety and feature other technical properties such as:

- Low power consumption on the controller side
- High switching frequency
- No contact bounce
- Wear-free switching
- Vibration resistance
- Use independent of positioning
- No need for mechanical parts
- Long service life
- High insulation voltage

Accordingly, optocouplers are a good alternative to the traditional, mechanical relay interfaces. Modules with different input voltages and enclosure technologies are available for industrial use.

CE marking

Weidmüller's optocouplers carry the CE mark and comply with the requirements laid down by EN 50 081 part 1 and EN 50 082 part 2. They can be used in a wide range of applications and industries.

Suitable ESD measures must be taken during installation. Overvoltage protection must be provided for long leads as protection from lightning.

Optocoupler – Overview

Our highlight
MICROSERIES

Coupler modules in terminal format

The slot-in width of 6.1 mm allows space-saving installation of the **MICROSERIES** relays in industrial automation applications. The **MICROSERIES** is particularly suitable for the modification and extension of equipment and machinery, where it helps to make optimum use of the limited space available in switchgear cabinets.

Marking

The tab surfaces enable equipment to be clearly marked using a WS marker.



Holding and ejecting mechanism

The innovative holding and ejecting mechanism clips the assembled module securely onto the base terminal. Using the reliable eject function, the coupler can be removed quickly and simply from the base.

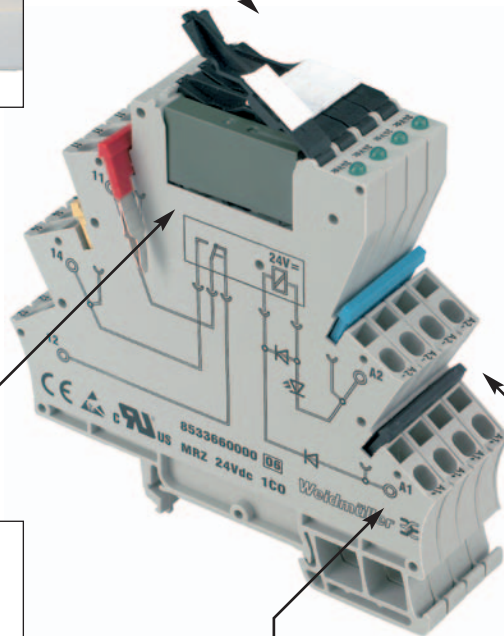

Relay and optocoupler module

Plug-in relay and optocoupler modules allow individual adjustment to function of the base module. Relay and optocouplers, are available with different power outputs, with either AgSnO and gold contacts.

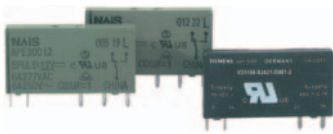

Connection technology

Most of our relay couplers are available with screw or tension clamp connections.



Pluggable cross-connectors

The ZQV 4N plug-in cross-connectors are available in various colours and with different numbers of poles. They allow reliable and distinct cross-connections between the four input and output potentials.

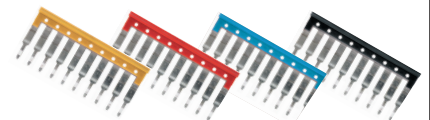

Optocoupler – Overview

Control side of the optocoupler interface

Basic structure of the optocoupler interface:

The key component is the actual optoelectronic unit (optocoupler) which is responsible for the coupling.

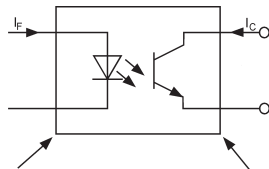

One important variable of this component is the current transfer rate (CTR). The CTR factor is stated as a percentage and describes the relationship between dispensed input current I_F and the maximum available output current I_C .

Example: $I_F = 10 \text{ mA}$; $CTR = 100 \%$ \Rightarrow $I_C = 10 \text{ mA}$.

However, the CTR variable is influenced by various parameters such as ambient temperature, degree of efficiency of the luminescence diode or geometric dimensions within the component, and itself declines over time. This means that the switching thresholds change over time, partly as a result of ageing.

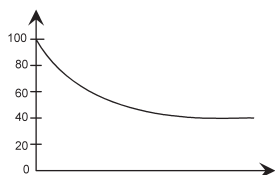

In order to eliminate this effect as far as possible, Weidmüller optocouplers use almost exclusively optoelectronic semiconductors with high long-term stability in terms of CTR behaviour.

The insulation strength of the component is also important, because the actual coupling of the input and output circuits results from optical transfer. This means that even in the event of a fault, the optical component will guarantee separation of both circuits. By using optoelectronic coupling elements in accordance with DIN VDE 0884, Weidmüller's optocouplers represent the ultimate in safety.

The circuitry within the module as a whole also deserves to be mentioned, with features including "protective separation" in accordance with DIN VDE 0106 part 101.

Optocouplers for galvanic isolation or "protective separation"

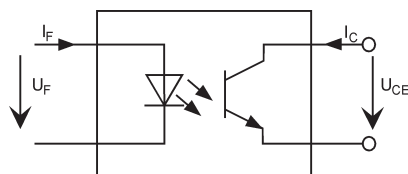

The partial discharge level test as per DIN VDE 0884 is the primary prerequisite for "protective separation" with optoelectronic coupler modules. Double or reinforced insulation for "protective separation" must be partially discharge-proof. High-voltage testing, a standard procedure for relays, is not possible with semiconductors because it may actually destroy them. In the case of coupler modules with integrated optocouplers, "protective separation" for the specified rated voltage is achieved when the following requirements are satisfied:

- Testing of the optocouplers as per DIN VDE 0884
- Adherence to creepage and clearance path on circuit boards and connection elements in accordance with EN 50 178, DIN VDE 0106 and 0109.

A distinction is made between three basic circuits on the input side of the optocoupler interfaces:

- Pure DC input

Here there is a reversed polarity protection diode which prevents damage to the module in the case of reversed input polarity

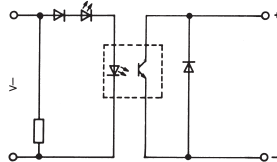

- AC/DC input

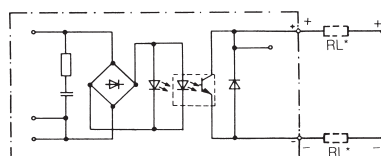

Here it is not possible to reverse the polarity of the DC input signal. The disadvantage of the AC/DC input circuit

(with DC signal trigger) is the lower switching frequency of the module, because the charge capacitor (C_L , necessary for AC input signals) reduces the maximum switching frequency

- AC input

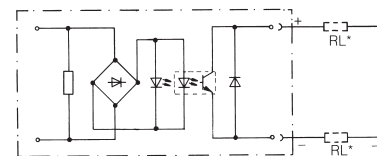

Here again, the charging capacity has a major influence on the maximum switching frequency of the module as a whole. Weidmüller optocouplers with AC/DC or AC input signals are rated for mains frequencies of approx. 40 – 60 Hz. In the case of AC input signals, the maximum switching frequency of the optocoupler module is less than half the mains frequency. A higher switching frequency is not possible, because this would result in constant switching in the rhythm of the mains frequency.

Load side of the optocoupler interface

Weidmüller optocoupler modules have been dimensioned and developed for use in a wide range of applications and industries.

Possible demands made on the load side of the optocoupler modules include:

- power amplification
- AC/DC and DC/AC signal conditioning
- short-circuit protection
- interference immunity

To meet these requirements, the modules are assembled with additional electronic elements which then define the overall functioning of the optocoupler module.

Accordingly, there are always two versions for the load side of the optocoupler: output as a 2-pole or 3-pole circuit.

Optocoupler – Overview

Optocoupler

2-pole DC output

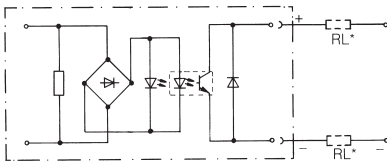

The 2-pole DC output can be compared with a conventional switch. In this version it does not matter where the load is located (in the output circuit), although the necessary output supply voltage must be available with the right polarity.

Optocoupler modules are usually indicated with an output supply voltage range of, for example, 5 ... 48 Vdc. The voltage should on no account ever be lower or higher than these values. The load current should not be higher than the stated maximum output current. If current constantly exceeds this value, the output stage will be destroyed.

Derating diagrams show the relationship of output current to ambient temperature (indicated for the products on the following pages).

2-pole AC output

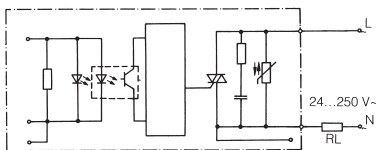

A special semiconductor module (TRIAC) is used for switching AC voltage in the output stage of the optocoupler. Here, as with the DC output, consideration must also be given to the key data such as voltage, frequency, maximum load current and ambient temperature.

Use of the zero voltage switch ensures that the load is only switched on at the zero crossover of the voltage. The modules are always equipped with suitable protection elements (varistor, RC combination) as protection from non-permissible voltage peaks.

3-pole DC output

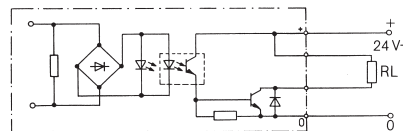

In order to function reliably, this kind of output level required potential-related output supply voltage with a single output. It is rated for either positive switching (joint reference potential: GND or 0V) or negative switching (joint reference potential: positive voltage pole).

Standards

The following standards are complied with:

- EN 50 178:
Electronic equipment for use in high current installations
- DIN VDE 01206 part 101:
Protection from dangerous body currents, basic requirements for "protective separation" in electrical equipment
- DIN VDE 0884:
Optoelectronic couplers for "protective separation"
- DIN VDE 0109:
Insulation coordination for equipment within low-voltage systems, including creepage and clearance distances for configured printed circuit boards

Protection circuits

All optocoupler modules have a protection circuit in the output (usually with a freewheel diode).

The load side must be protected to prevent interference signals from coupling into other lines.

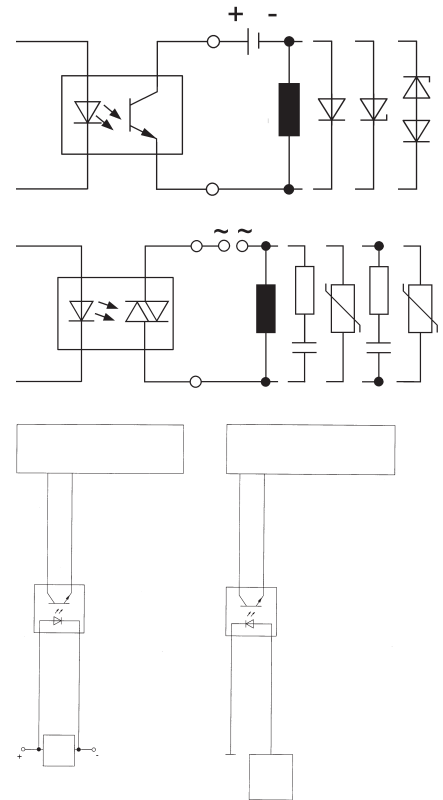

Optocoupler – Overview

Enclosure types for relay couplers

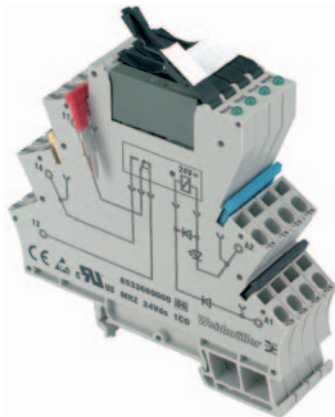
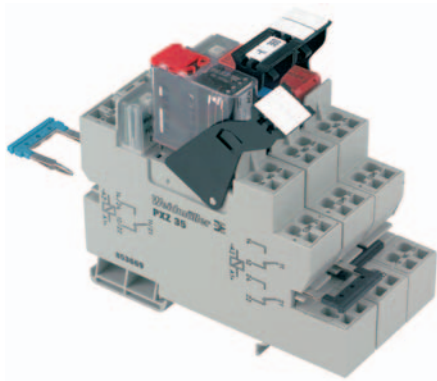

PLUGSERIES

The modular component system represents a new generation of plug-in optocouplers. The key element is a PXS (screw clamp) or PXZ (tension clamp) innovative relay base. Both products reflect the functionality of relays or optos and Weidmüller's experience in their commercial use. PLUGSERIES is the ideal connection system between the Solid State Relay (SSR) and the application.

Modular principle

The new PLUGSERIES is extremely easy to handle. Commercially available SSRs are simply plugged in, retaining clips provide a firm hold, and LED displays with a recovery diode can be plugged in.

- SSRs simply plugged in: suitable for standard and TD designs
- Independent connection technology: screw or tension clamp technology, nominal cross-sectional area 0.5 ... 2.5 mm²
- Robust design of the retaining/dismantling hook
- Control voltage 24 Vac/Vdc
- Rated switching voltage 24 Vdc, 24 Vac/Vdc, 230 Vac
- Up to 5 A continuous current
- Minimum wiring workload thanks to ZQV 2.5N plug-in cross-connectors
- Modular system allows easy handling:
 - Relay base, LED display, retaining hook and SSR
 - Clips on to the TS 35
 - Marking with WS tabs on retaining hook
- Plug-in LED with recovery diode.

MICROSERIES

Relay and optocoupler versions in the MICROSERIES are used in industrial automation applications for separating and coupling digital input and output signals. The space saving design makes them perfectly suited for use in sub-distributors or switchgear cabinets. With its compact shape, MICROSERIES combines the functions of the classical coupling level with the terminal level.

- Slot-in width 6.1 mm
- Pluggable cross-connection for four input and output potentials
- Tried and tested ZQV 4N cross-connector system
- Wide range of input voltage from 5 .. 230 V
- LED power light, reverse polarity protection diode, freewheel diode
- WEMID enclosure material (flammability V0 as per UL 94)
- Innovative holding and eject mechanism
- Marking surface to take standard WS 12/6 marking

CE marking

Weidmüller's relay couplers carry the CE mark and comply with the requirements laid down by EN 50 081 part 1 and EN 50 082 part 2. They can be used in both industrial-scale and smaller-scale applications.

Suitable ESD measures must be taken during installation. Overvoltage protection must be provided for long leads as protection from lightning.

WAVESERIES

Innovative electronic components require a housing or enclosure which reflects their specific functions. It must allow adjusting and control functions and support technical requirements, such as heat dissipation or electromagnetic compatibility. A compact design saves space in the switchgear cabinet and reduces assembly costs. Ergonomic design is increasingly important for top-quality relay coupler interfaces.

The WAVESERIES fulfils all these criteria, with outstanding features including:

- Assembly without tools
- Printed circuit board
- Pluggable PCB
- ZQV 2.5V pluggable cross-connection
- Hinged transparent cover
- Marking with WS tabs
- Clips onto TS 35

Connection systems

The user can choose between BLZ screw plug-in connectors and BLZF tension clamp plug-in systems, up to 2.5 mm² and finely stranded, for the greatest possible flexibility when wiring up the circuits.

Printed circuit board

If the lateral locking hook is squeezed on the head end, it can be pulled out of the enclosure together with the connection level and the circuit board. The circuit board can only be pulled out without current voltage.

Cross-connection

The ZQV 2.5 N/2 cross-connectors can be used to connect rows of Waveseries enclosures. The cross-connection can take up to 8 A of current. It can be used for bridging the supply voltage from one electronic module to another. The voltage at the cross-connection must not exceed 50 V.

Ventilation slits

Diagonal ventilation slits ventilate the lower parts of the enclosures and keep temperatures moderate.

Optocoupler – Overview

Enclosure types for relay couplers

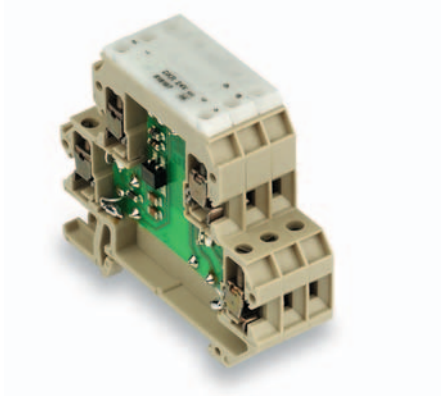

DK SERIES

All components in the DKO mini-coupler are of an extremely slim design: use of advanced surface-mounted parts (SMD) allows the width to be kept to just 6 mm. The range includes 4 or 5 screw connections for conductor cross-section of 0.5 ... 4 mm². The mini couplers offer a wide range of applications for coupling digital sensor/actuators or signals with automation devices and the process field. DKO optocouplers can be used to pick up and standardise signals from the field with different voltages.

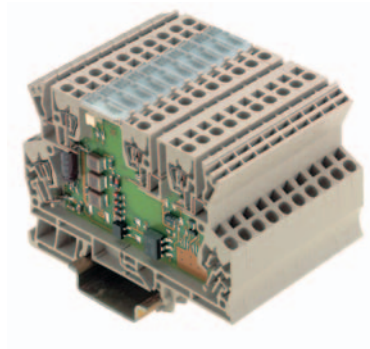

MCZ SERIES

The MCZ enclosure is only 6 mm wide and one of the narrowest of its kind. Its outstanding technical features include:

- Tension clamp connection to reduce assembly costs
- Integrated input/output cross-connection to reduce wiring workload

MCZO mini-conditioners (optocouplers) have 4 or 5 tension spring connections. The cross-section of the clamping conductor is 0.5 ... 1.5 mm².



EG SERIES

The EG7 integral housing has a special status because it is suited only for the installation of 10 mm compact optocouplers. EG7 optocouplers can be mounted on either the TS 32 or TS 35. An RS EG7 snap-in base is also available for the OST plug-in optocouplers.

The closed EG 7 enclosures are equipped with tension clamp unit for screw connection.

Conductors with the following cross-sections can be connected:

- Integral housing EG 7: 0.5 ... 1.5 mm²
- OST clip-in base: 0.5 ... 2.5 mm²

PLUGSERIES

Output current 24 Vdc / 2.5A

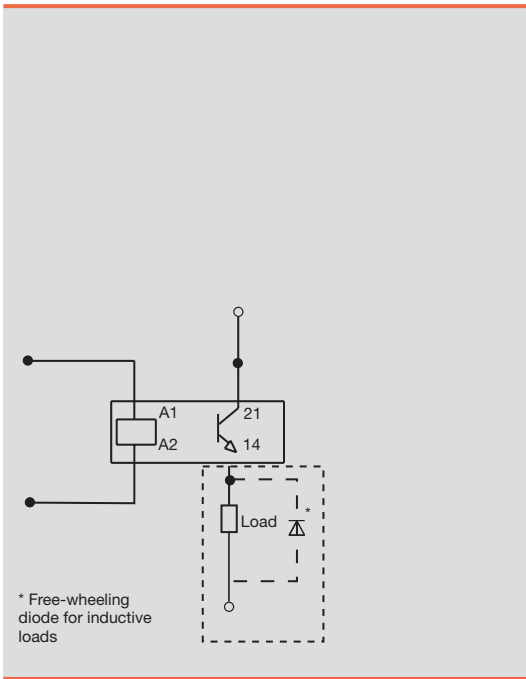
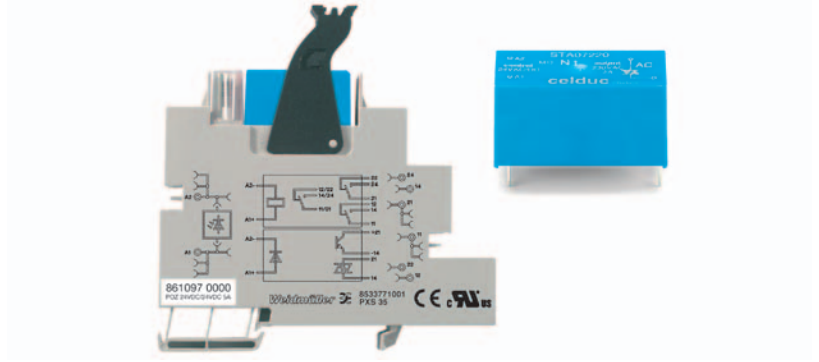

Output			
Output voltage	0 V ... 30 Vdc		
Output current (max.)	2.5 A		
Voltage drop at max. load	< 0.4 V		
Block-state curr. (closed circuit curr.)	< 1 mA		
Switch-on delay/Switch-off delay	2ms/18ms		
Short-circuit proof/Protective circuit	No/integrated freewheel diode		
General data			
Ambient temp., fitted w/o distance	-40 °C...+50 °C		
Ambient temp., fitted w. distance	-40 °C...+50 °C		
Storage temperature	-40 °C...+50 °C		
Approvals	cUL, UL recognized		
Insulation coordinates (EN 50 178)			
Standards	EN 50178		
Rated voltage	300V		
Rated impulse voltage	2.5kV		
Creepage and clearance path input - output	8mm		
Overvoltage category	III		
Pollution severity	2		
Dimensions		Screw connection	Tension clamp connection
Clamping range (rating- / min. / max.)	mm ²	2.5 / 0.5 / 2.5	2.5 / 0.5 / 2.5
Length x width x height	mm	92.0 / 15.3 / 95.0	92.0 / 15.3 / 87.0
Information			

K

Ordering data

Input		24VDC/24VDC 2.5A
Rated voltage		15 Vdc...30 Vdc
Rated current		approx. 10mA
Power rating		250 mW
Auxiliary voltage		No
Status indicator		LED green

Ordering data Complete module

Screw connection	Type	POS 24VDC/24VDC 2A
	Order No.	8610840000
Tension clamp connection	Type	POZ 24VDC/24VDC 2A
	Order No.	8610920000

Ordering data Spare relay, pluggable

	Type	SSR 24V ACDC/24 VDC 2A
	Order No.	8576340000

Information

PLUGSERIES

Output current 24 Vdc / 5A

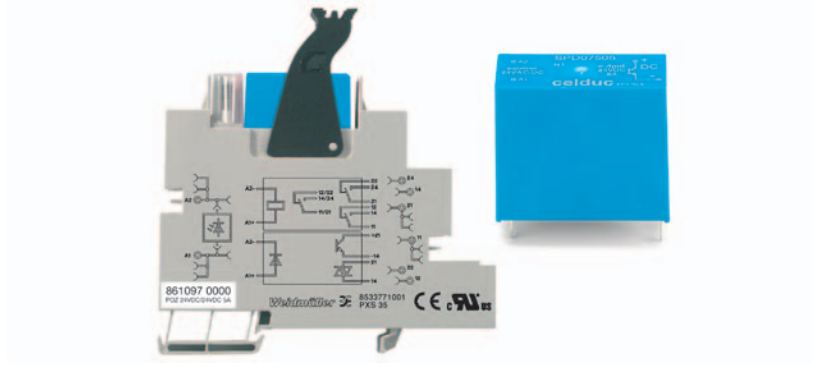

Optocoupler

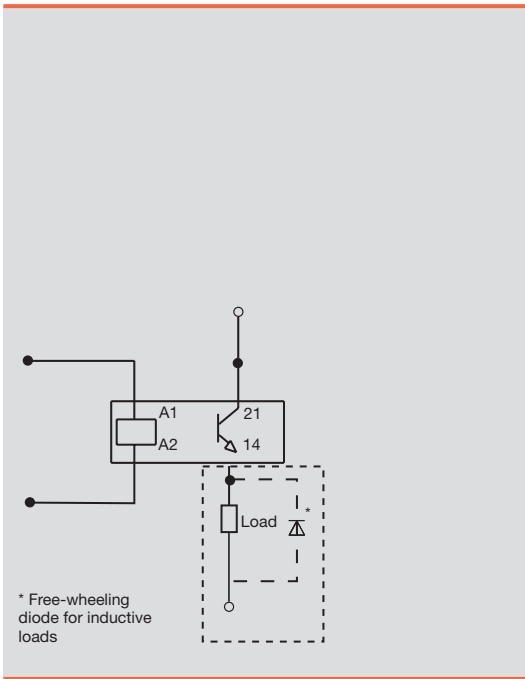

Output			
Output voltage	0 V ... 30 Vdc		
Output current (max.)	5 A		
Voltage drop at max. load	< 0.3 V		
Block-state curr. (closed circuit curr.)	< 1 mA		
Switch-on delay/Switch-off delay	2ms/18ms		
Short-circuit proof/Protective circuit	No/integrated freewheel diode		
General data			
Ambient temp., fitted w/o distance	-40 °C...+50 °C		
Ambient temp., fitted w. distance	-40 °C...+50 °C		
Storage temperature	-40 °C...+50 °C		
Approvals	cUL, UL recognized		
Insulation coordinates (EN 50 178)			
Standards	EN 50178		
Rated voltage	300V		
Rated impulse voltage	2.5kV		
Creepage and clearance path input - output	8mm		
Overvoltage category	III		
Pollution severity	2		
Dimensions		Screw connection	Tension clamp connection
Clamping range (rating- / min. / max.)	mm ²	2.5 / 0.5 / 2.5	2.5 / 0.5 / 2.5
Length x width x height	mm	92.0 / 15.3 / 95.0	92.0 / 15.3 / 87.0
Information			

Ordering data

Input		24VDC/24VDC 5A
Rated voltage		15 Vdc...30 Vdc
Rated current		approx. 10mA
Power rating		250 mW
Auxiliary voltage		No
Status indicator		LED green

Ordering data Complete module

Screw connection	Type	POS 24VDC/24VDC 5A
	Order No.	861090000
Tension clamp connection	Type	POZ 24VDC/24VDC 5A
	Order No.	861097000

Ordering data Spare relay, pluggable

	Type	SSR 24V ACDC/24 VDC 5A
	Order No.	857635000

Information

Articles with coloured order number are kept permanently in stock at the central warehouse in Germany. Delivery times see page X.2

K

PLUGSERIES

Output current 24 Vuc / 1A

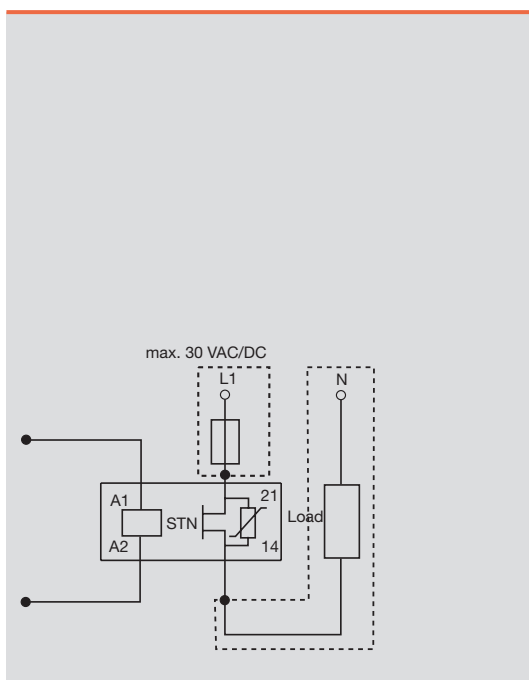
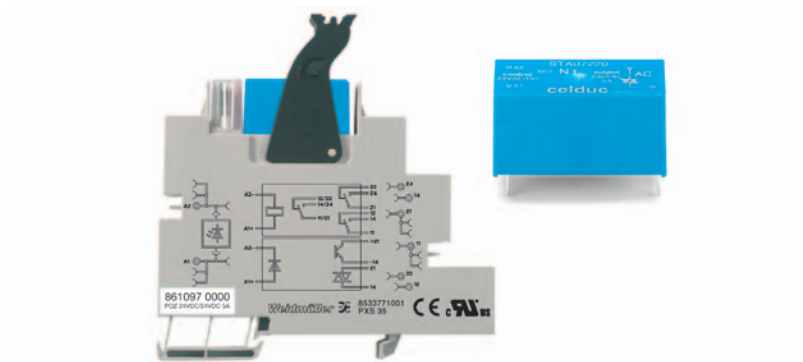

Output			
Output voltage	0 V ... 30 Vuc		
Output current (max.)	1 A		
Voltage drop at max. load	< 0.9 V		
Block-state curr. (closed circuit curr.)	< 1 mA		
Switch-on delay/Switch-off delay	5ms/12ms		
Short-circuit proof/Protective circuit	No/integrated freewheel diode		
General data			
Ambient temp., fitted w/o distance	-40 °C...+50 °C		
Ambient temp., fitted w. distance	-40 °C...+50 °C		
Storage temperature	-40 °C...+50 °C		
Approvals	cUL, UL recognized		
Insulation coordinates (EN 50 178)			
Standards	EN 50178		
Rated voltage	300V		
Rated impulse voltage	4.0kV		
Creepage and clearance path input - output	8mm		
Overvoltage category	III		
Pollution severity	2		
Dimensions		Screw connection	Tension clamp connection
Clamping range (rating- / min. / max.)	mm ²	2.5 / 0.5 / 2.5	2.5 / 0.5 / 2.5
Length x width x height	mm	92.0 / 15.3 / 95.0	92.0 / 15.3 / 87.0
Information			

Ordering data

Input

Rated voltage
Rated current
Power rating
Auxiliary voltage
Status indicator

24VDC/24VUC 1A

15 Vdc...30 Vdc
approx. 10mA
250 mW
No
LED green

Ordering data

Complete module

Screw connection	Type	POS 24VDC/24VUC 1A
	Order No.	8610890000
Tension clamp connection	Type	POZ 24VDC/24VUC 1A
	Order No.	8610960000

Ordering data

Spare relay, pluggable

Type	SSR 24V ACDC/24VACDC
Order No.	8576380000

Information

PLUGSERIES

Output current 230 Vac / 2A

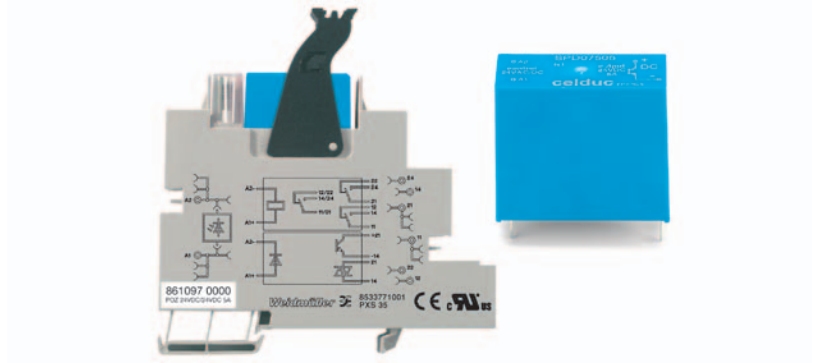

Optocoupler

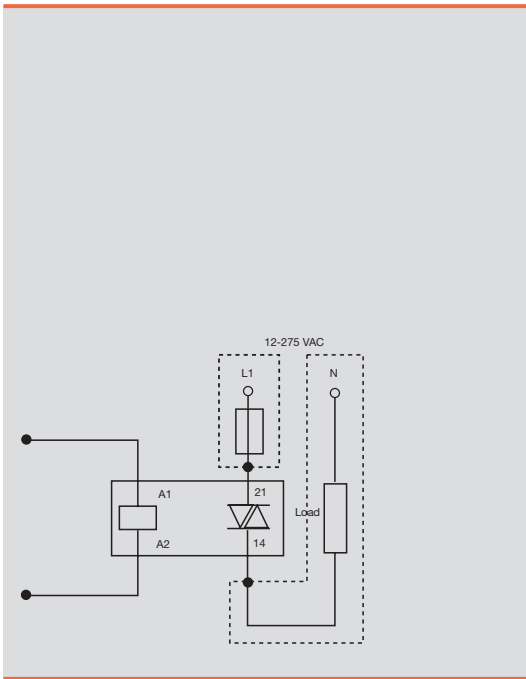

Output	
Output voltage	12 V ... 275 Vac
Output current (max.)	2 A
Voltage drop at max. load	< 1 V
Block-state curr. (closed circuit curr.)	< 1 mA
Switch-on delay/Switch-off delay	12ms/20ms
Short-circuit proof/Protective circuit	No/RC-element
General data	
Ambient temp., fitted w/o distance	-40 °C...+50 °C
Ambient temp., fitted w. distance	-40 °C...+50 °C
Storage temperature	-40 °C...+50 °C
Approvals	cUL, UL recognized
Insulation coordinates (EN 50 178)	
Standards	EN 50178
Rated voltage	300V
Rated impulse voltage	4.0kV
Creepage and clearance path input - output	8mm
Overvoltage category	III
Pollution severity	2
Dimensions	
Clamping range (rating- / min. / max.)	mm ² 2.5 / 0.5 / 2.5
Length x width x height	mm 92.0 / 15.3 / 95.0
Information	

Ordering data

Input		24VDC/230VAC 2A
Rated voltage		15 Vdc...30 Vdc
Rated current		approx. 10mA
Power rating		250 mW
Auxiliary voltage		No
Status indicator		LED green

Ordering data

Complete module				
Screw connection	Type	POS 24VDC/230VAC 2A		
	Order No.	8610860000		
Tension clamp connection	Type	POZ 24VDC/230VAC 2A		
	Order No.	8610930000		

Ordering data

Spare relay, pluggable				
	Type	SSR 24V ACDC/230VAC 2A		
	Order No.	8576370000		

Information

--	--	--	--	--

Articles with coloured order number are kept permanently in stock at the central warehouse in Germany. Delivery times see page X.2

PLUGSERIES

Output current 230 Vac / 4A

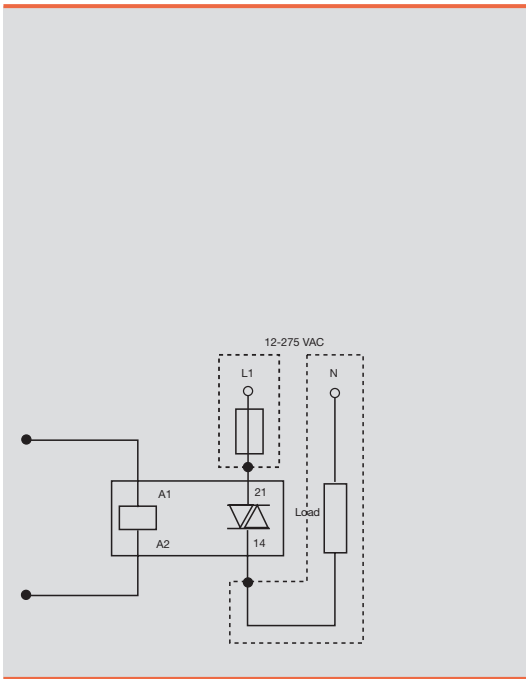
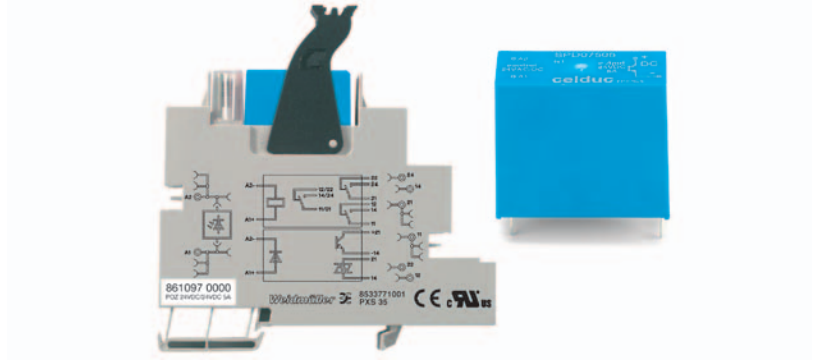

Output			
Output voltage	12 V ... 275 Vac		
Output current (max.)	3 A (4 A at 20°C)		
Voltage drop at max. load	< 1.1 V		
Block-state curr. (closed circuit curr.)	< 1 mA		
Switch-on delay/Switch-off delay	12ms/20ms		
Short-circuit proof/Protective circuit	No/RC-element		
General data			
Ambient temp., fitted w/o distance	-40 °C...+50 °C		
Ambient temp., fitted w. distance	-40 °C...+50 °C		
Storage temperature	-40 °C...+50 °C		
Approvals	cUL, UL recognized		
Insulation coordinates (EN 50 178)			
Standards	EN 50178		
Rated voltage	300V		
Rated impulse voltage	4.0kV		
Creepage and clearance path input - output	8mm		
Overtoltage category	III		
Pollution severity	2		
Dimensions		Screw connection	Tension clamp connection
Clamping range (rating- / min. / max.)	mm ²	2.5 / 0.5 / 2.5	2.5 / 0.5 / 2.5
Length x width x height	mm	92.0 / 15.3 / 95.0	92.0 / 15.3 / 87.0
Information			

K

Ordering data

Input		24VDC/230VAC 4A
Rated voltage		15 Vdc...30 Vdc
Rated current		approx. 10mA
Power rating		250 mW
Auxiliary voltage		No
Status indicator		LED green

Ordering data

Complete module				
Screw connection	Type	POS 24VDC/230VAC 4A		
	Order No.	8610910000		
Tension clamp connection	Type	POZ 24VDC/230VAC 4A		
	Order No.	8610980000		

Ordering data

Spare relay, pluggable				
	Type	SSR 24V ACDC/230VAC 4A		
	Order No.	8576360000		

Information

--	--	--	--	--

PLUGSERIES

Accessories

Schrack RP3SL

Relay for high switch-on current

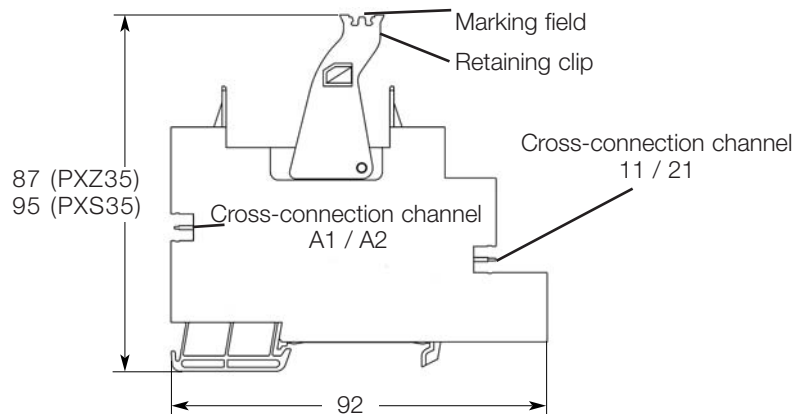

Technical data

Empty base

Rated current	16 A
Rated voltage	250 V
Voltage strength coil / contacts	> 4 kV
Protection	IP 20
Rated cross-sectional area	2.5 mm ²
Stripping length	8 mm
	10 mm
Ambient temperature	-40°C ... +60°C
Flammability class as per UL 94	V-0

screw connection
tension clamp

Tension clamp connection

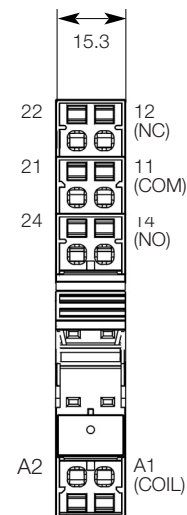

Screw connection

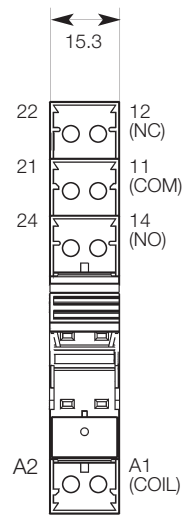

Order data

Empty base for assembly on the TS 35 mounting rail

Type	Qty	Order no.
Screw connection	10	8533771001
Tension clamp	10	8536691001

Retaining clip

PRC	100	8536700000
-----	-----	------------

LED display with freewheeling diode

6 ... 24 Vdc	PLED 24 Vdc	20	8536710000
LED red, 6 ... 24 Vdc	PLED 24 Vdc rot	20	8611010000
48 ... 60 Vdc	PLED 48 Vdc	20	8536720000
115 Vdc	PLED 115 Vdc	20	8536730000
12 ... 24 Vac	PLED 24 Vac	20	8536750000
115 Vac	PLED 120 Vac	20	8536760000
230 Vac	PLED 230 Vac	20	8536780000
LED red, 230 Vac	PLED 230 Vac rot	20	8611000000
RC combination 120...230 VAC/DC	PLRC 200 nF/200Ω	20	8566530000

Pluggable cross-connections

2-pole	black	ZQV 2.5N/4-2SW	60	1784270000
	red	ZQV 2.5N/4-2RT	60	1784280000
	blue	ZQV 2.5N/4-2BL	60	1784290000

Marking

10 x 5 mm	WS 10/5	200	1060860000
15 x 5 mm	WS 15/5	96	1609880000

Operating control display

DC version

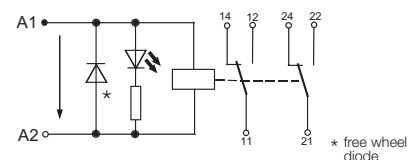

AC version

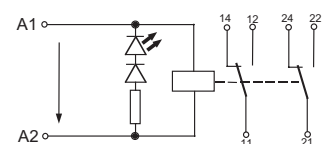

MICROSERIES

Output current 24 Vdc / 0.1A

Universal interface between control and sensor/actuator

- Pluggable cross-connection ZQV 4N
- Solid-state relay interchangeable
- Width 6.1 mm
- Screw or tension clamp connection technology
- Mounting on TS35

24VDC/24VDC 0.1A

120VUC/24VDC 0.1A

230VAC/24VDC 0.1A

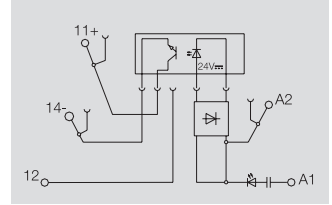
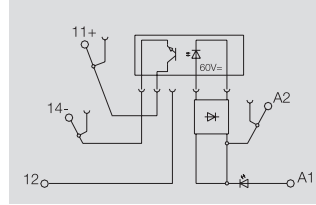
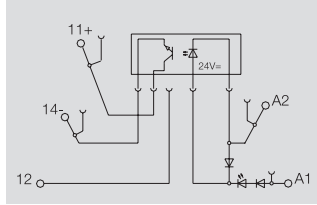

Technical data

Input

Rated voltage	24 Vdc +/- 20 %
Rated current	5.7mA
Power rating	140 mW
Max. input frequency	
Auxiliary voltage	No
Status indicator	LED green

Output

Output voltage	3 V... 48 Vdc
Output current (max.)	0.1 A
Voltage drop at max. load	< 1 V
Block-state curr. (closed circuit curr.)	< 1 mA
Switch-on delay/Switch-off delay	35µs/355µs
Short-circuit proof/Protective circuit	No/integrated freewheel diode

General data

Ambient temp., fitted w. distance	-25 °C...+50 °C
Ambient temp., fitted w/o distance	-25 °C...+50 °C
Storage temperature	-40 °C...+60 °C
Approvals	CE cRUus

Insulation coordinates (EN 50 178)

Standards	EN 50178
Rated voltage	300
Rated impulse voltage	4.0
Creepage and clearance path input - output	>= 5.5 mm
Overvoltage category	III
Pollution severity	2

Rated voltage	24 Vdc +/- 20 %
Rated current	5.7mA
Power rating	140 mW
Max. input frequency	
Auxiliary voltage	No
Status indicator	LED green

Output voltage	3 V... 48 Vdc
Output current (max.)	0.1 A
Voltage drop at max. load	< 1 V
Block-state curr. (closed circuit curr.)	< 1 mA
Switch-on delay/Switch-off delay	35µs/355µs
Short-circuit proof/Protective circuit	No/integrated freewheel diode

Ambient temp., fitted w. distance	-25 °C...+50 °C
Ambient temp., fitted w/o distance	-25 °C...+50 °C
Storage temperature	-40 °C...+60 °C
Approvals	CE cRUus

Standards	EN 50178
Rated voltage	300
Rated impulse voltage	4.0
Creepage and clearance path input - output	>= 5.5 mm
Overvoltage category	III
Pollution severity	2

Rated voltage	120 Vuc + 10 %/ -15 %
Rated current	3.4mA ac/2.8mA dc
Power rating	340 mW / 0.4 VA
Max. input frequency	dc: 10 Hz /ac: 3 Hz
Auxiliary voltage	No
Status indicator	LED green

Output voltage	3 V... 48 Vdc
Output current (max.)	0.1 A
Voltage drop at max. load	< 1 V
Block-state curr. (closed circuit curr.)	< 1 mA
Switch-on delay/Switch-off delay	< 6.5 ms/< 10 ms
Short-circuit proof/Protective circuit	No/integrated freewheel diode

Ambient temp., fitted w. distance	-25 °C...+50 °C
Ambient temp., fitted w/o distance	-25 °C...+50 °C
Storage temperature	-40 °C...+60 °C
Approvals	CE cRUus

Standards	EN 50178
Rated voltage	300
Rated impulse voltage	4.0
Creepage and clearance path input - output	>= 5.5 mm
Overvoltage category	III
Pollution severity	2

Rated voltage	230 Vac +/- 10 %
Rated current	7.4mA
Power rating	1.7 VA
Max. input frequency	3 Hz
Auxiliary voltage	No
Status indicator	LED green

Output voltage	3 V... 48 Vdc
Output current (max.)	0.1 A
Voltage drop at max. load	< 1 V
Block-state curr. (closed circuit curr.)	< 1 mA
Switch-on delay/Switch-off delay	< 6.5 ms/< 10 ms
Short-circuit proof/Protective circuit	No/integrated freewheel diode

Ambient temp., fitted w. distance	-25 °C...+50 °C
Ambient temp., fitted w/o distance	-25 °C...+50 °C
Storage temperature	-40 °C...+60 °C
Approvals	CE cRUus

Standards	EN 50178
Rated voltage	300
Rated impulse voltage	4.0
Creepage and clearance path input - output	>= 5.5 mm
Overvoltage category	III
Pollution severity	2

Dimensions

Clamping range (rating- / min. / max.)	mm ²
Length x width x height	mm

Information

Screw connection Tension clamp c.

MOS 24Vdc / 24Vdc 0.1A	2.50 / 0.50 / 4	2.50 / 0.50 / 4
MOZ 5Vdc / 24Vdc 0.1A	93.0 x 6.1 x 92.0	93.0 x 92.0

CE, UL/UR	Mounting on TS35
-----------	------------------

Screw connection Tension clamp c.

MOS 120Vuc / 24Vdc 0.1A	2.50 / 0.50 / 4	1.50 / 0.50 / 2.50
MOZ 120Vuc / 24Vdc 0.1A	93.0 x 6.1 x 92.0	93.0 x 6.1 x 92.0

CE, UL/UR	Mounting on TS35
-----------	------------------

Screw connection Tension clamp c.

MOS 230Vac / 24Vdc 0.1A	2.50 / 0.50 / 4	1.50 / 0.50 / 2.50
MOZ 230Vac / 24Vdc 0.1A	93.0 x 6.1 x 92.0	93.0 x 6.1 x 92.0

CE, UL/UR	Mounting on TS35
-----------	------------------

Ordering data

Connection technology

Screw connection
Tension clamp c.

Type	(Qty.=10)	Order No.
MOS 24Vdc / 24Vdc 0.1A		8607340000
MOZ 5Vdc / 24Vdc 0.1A		8633010000

Type	(Qty.=10)	Order No.
MOS 120Vuc / 24Vdc 0.1A		8607690000
MOZ 120Vuc / 24Vdc 0.1A		8607730000

Type	(Qty.=10)	Order No.
MOS 230Vac / 24Vdc 0.1A		8607710000
MOZ 230Vac / 24Vdc 0.1A		8607750000

Information

Accessories

Information

Pluggable cross-connection ZQV 4N

Pluggable cross-connection ZQV 4N

Pluggable cross-connection ZQV 4N

MICROSERIES

Output current 24 Vdc / 2A

Universal interface between control and sensor/actuator

- Pluggable cross-connection ZQV 4N
- Solid-state relay interchangeable
- Width 6.1 mm
- Screw or tension clamp connection technology
- Mounting on TS35

24VDC/24VDC 2A

120VUC/24VDC 2A

230VAC/24VDC 2A

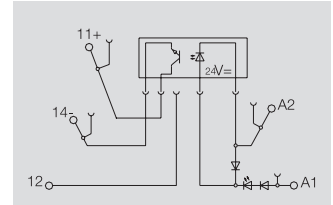
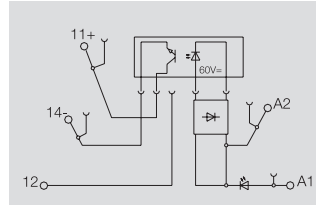
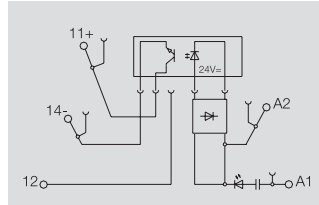

Technical data

Input

Rated voltage	24 Vdc +/- 20 %
Rated current	5.7mA
Power rating	140 mW
Max. input frequency	300 Hz
Auxiliary voltage	No
Status indicator	LED green

Output

Output voltage	3 V...33 Vdc
Output current (max.)	2 A
Voltage drop at max. load	< 120 mV
Block-state curr. (closed circuit curr.)	approx. 10 µA
Switch-on delay/Switch-off delay	< 55 µs/< 1.2 ms
Short-circuit proof/Protective circuit	No/integrated freewheel diode

General data

Ambient temp., fitted w. distance	-25 °C...+50 °C
Ambient temp., fitted w/o distance	-25 °C...+50 °C
Storage temperature	-40 °C...+60 °C
Approvals	CE cRUus

Insulation coordinates (EN 50 178)

Standards	EN 50178
Rated voltage	300
Rated impulse voltage	4.0
Creepage and clearance path input - output	>= 5.5 mm
Overvoltage category	III
Pollution severity	2

120 Vuc + 10 %/ -15 %

Rated current	3.4mA ac/2.8mA dc
Power rating	340 mW / 0.4 VA
Max. input frequency	dc: 10 Hz /ac: 3 Hz
Auxiliary voltage	No
Status indicator	LED green

Output voltage	3 V...33 Vdc
Output current (max.)	2 A
Voltage drop at max. load	< 120 mV
Block-state curr. (closed circuit curr.)	approx. 10 µA
Switch-on delay/Switch-off delay	< 6.5 ms/< 10 ms
Short-circuit proof/Protective circuit	No/integrated freewheel diode

Ambient temp., fitted w. distance	-25 °C...+50 °C
Ambient temp., fitted w/o distance	-25 °C...+50 °C
Storage temperature	-40 °C...+60 °C
Approvals	CE cRUus

Standards	EN 50178
Rated voltage	300
Rated impulse voltage	4.0
Creepage and clearance path input - output	>= 5.5 mm
Overvoltage category	III
Pollution severity	2

230 Vac +/- 10 %

Rated current	7.4mA
Power rating	1.7 VA
Max. input frequency	3 Hz
Auxiliary voltage	No
Status indicator	LED green

Output voltage	3 V...33 Vdc
Output current (max.)	2 A
Voltage drop at max. load	< 120 mV
Block-state curr. (closed circuit curr.)	approx. 10 µA
Switch-on delay/Switch-off delay	< 6.5 ms/< 10 ms
Short-circuit proof/Protective circuit	No/integrated freewheel diode

Ambient temp., fitted w. distance	-25 °C...+50 °C
Ambient temp., fitted w/o distance	-25 °C...+50 °C
Storage temperature	-40 °C...+60 °C
Approvals	CE cRUus

Standards	EN 50178
Rated voltage	300
Rated impulse voltage	4.0
Creepage and clearance path input - output	>= 5.5 mm
Overvoltage category	III
Pollution severity	2

Dimensions

Clamping range (rating- / min. / max.)	mm ²
Length x width x height	mm

Information

Screw connection Tension clamp c.

MOS 24Vdc / 24Vdc 2A	2.50 / 0.50 / 4	1.50 / 0.50 / 2.50
MOZ 24Vdc / 24Vdc 2A	93.0 x 6.1 x 92.0	93.0 x 6.1 x 92.0

CE, UL/UR
Mounting on TS35

Screw connection Tension clamp c.

MOS 120Vuc / 24Vdc 2A	2.50 / 0.50 / 4	1.50 / 0.50 / 2.50
MOZ 120Vuc / 24Vdc 2A	93.0 x 6.1 x 92.0	93.0 x 6.1 x 92.0

CE, UL/UR
Mounting on TS35

Screw connection Tension clamp c.

MOS 230Vac / 24Vdc 2A	2.50 / 0.50 / 4	1.50 / 0.50 / 2.50
MOZ 230Vac / 24Vdc 2A	93.0 x 6.1 x 92.0	93.0 x 6.1 x 92.0

CE, UL/UR
Mounting on TS35

Ordering data

Connection technology

Screw connection
Tension clamp c.

Type	(Qty.=10)	Order No.
MOS 24Vdc / 24Vdc 2A		8607350000
MOZ 24Vdc / 24Vdc 2A		8607370000

Type	(Qty.=10)	Order No.
MOS 120Vuc / 24Vdc 2A		8607700000
MOZ 120Vuc / 24Vdc 2A		8607740000

Type	(Qty.=10)	Order No.
MOS 230Vac / 24Vdc 2A		8607720000
MOZ 230Vac / 24Vdc 2A		8607760000

Information

Accessories

Information

Pluggable cross-connection
ZQV 4N

Pluggable cross-connection
ZQV 4N

Pluggable cross-connection
ZQV 4N

Articles with coloured order number are kept permanently in stock at the central warehouse in Germany.
Delivery times see page X.2

MICROSERIES

Plug-in solid state relay

SSS Relay

Switching current 100 mA

SSS Relay

Switching current 2 A



Technical data

Input	
	Nominal control voltage
Control voltage	min / max
Control current at $U_{IN} = 24\text{ V}$	
Release voltage	
Control circuit resistance	
Output	
Switching voltage	
Switching/continuous current at $U_A > 5\text{ Vdc}$	
Conducting-state voltage	
Insulation	
Test voltage between control circuit / switching circuit	
Other data	
Operation temperature range	
Storage temperature range	
Weight	
Approvals	
* Ambient temperature 20°C	
Main-line wiring diagram	

24 Vdc	60 Vdc
Control voltage	16 Vdc / 30 Vdc
Control current at $U_{IN} = 24\text{ V}$	7 mA \pm 10 %
Release voltage	10 Vdc
Control circuit resistance	ca. 4 kOhm
Switching voltage	Bipolar transistor
Switching/continuous current at $U_A > 5\text{ Vdc}$	3 ... 48 Vdc
Conducting-state voltage	100 mAdc
Test voltage between control circuit / switching circuit	< 1 Vdc
Operation temperature range	2.5 kV
Storage temperature range	-20°C ... +60°C
Weight	-40°C ... +70°C
Approvals	3.65 g
	

24 Vdc	60 Vdc
Control voltage	18 Vdc / 30 Vdc
Control current at $U_{IN} = 24\text{ V}$	7 mA \pm 10 %
Release voltage	10 Vdc
Control circuit resistance	ca. 3.2 kOhm
Switching voltage	MOS-FET
Switching/continuous current at $U_A > 5\text{ Vdc}$	3 ... 33 Vdc
Conducting-state voltage	2 Adc
Test voltage between control circuit / switching circuit	< 120 mVdc
Operation temperature range	2.5 kV
Storage temperature range	-20°C ... +60°C
Weight	-40°C ... +70°C
Approvals	3.65 g
	

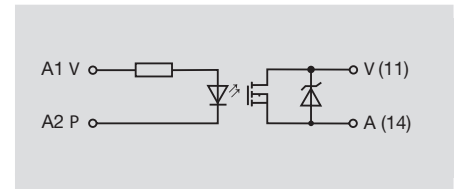
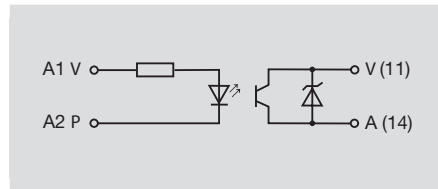

For other data see also <http://em.tycoelectronics.com>

Order data

Nominal control voltage	24 Vdc	60 Vdc
Order no.	4061180000	4061230000

Type	Order no.
SSS Relay 24 V / 24 V 0.1 Adc	4061180000
SSS Relay 60 V / 24 V 0.1 Adc	4061230000

Type	Order no.
SSS Relay 24 V / 24 V 2 Adc	4061190000
SSS Relay 60 V / 24 V 2 Adc	4061200000

Dimensional drawings

Print picture

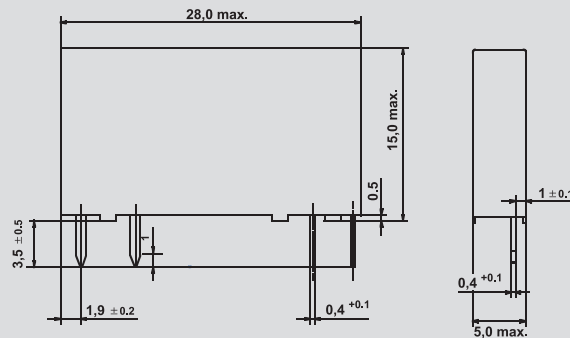
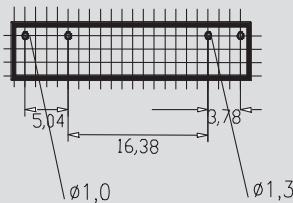

MICROSERIES

Accessories

General data – MICROSERIES

Pluggable cross-connection

Type	No. of poles	Qty	Order no.
Yellow			
ZQV 4N / 2 GE	2	60	1758250000
ZQV 4N / 3 GE	3	60	1762630000
ZQV 4N / 4 GE	4	60	1762620000
ZQV 4N / 10 GE	10	20	1758260000
ZQV 4N / 41 GE	41	10	1758270000
Red			
ZQV 4N / 2 RT	2	60	1793950000
ZQV 4N / 3 RT	3	60	1793980000
ZQV 4N / 4 RT	4	60	1794010000
ZQV 4N / 10 RT	10	20	1794040000
ZQV 4N / 41 RT	41	10	1794070000
Blue			
ZQV 4N / 2 BL	2	60	1793960000
ZQV 4N / 3 BL	3	60	1793990000
ZQV 4N / 4 BL	4	60	1794020000
ZQV 4N / 10 BL	10	20	1794050000
ZQV 4N / 41 BL	41	10	1794080000
Black			
ZQV 4N / 2 SW	2	60	1793970000
ZQV 4N / 3 SW	3	60	1794000000
ZQV 4N / 4 SW	4	60	1794030000
ZQV 4N / 10 SW	10	20	1794060000
ZQV 4N / 41 SW	41	10	1794090000

Technical data

Clamping conductor		Tension clamp connection	Screw connection
Solid H07V-U	mm ²	0.5 ... 2.5	0.5 ... 4.0
Flexible H07V-K	mm ²	0.5 ... 2.5	0.5 ... 2.5
"f" with wire end ferrule as per DIN 46 228 / 1	mm ²	0.5 ... 1.5	0.5 ... 1.5
"f" with wire end ferrule with plastic collar	mm ²	0.5 ... 1.5	0.5 ... 1.5
Max. clamping range	mm ²	0.13 ... 2.5	0.13 ... 4.0
Plug gauge as per IEC 60 947-1	size	A 2	A 3

General technical data

Rated torque		-	0.6
Constant current of the cross-connection 2-pole	A	10	10
Constant current of the cross-connection multi-pole	A	10	10
Stripping length	mm	10	7
Protection		IP 20	IP 20
Enclosure material		Wemid	Wemid
Flammability class as per UL 94		V-0	V-0
Rated current	A	6	6
Rated voltage	V	250	250

Other accessories

Type		Qty	Order no.
Marker			
WS 12/6	12 x 6 mm	200	1061160000
Labels, laser mark			
LM MT 300 15/6 ge	484 labels/Bogen	10	1686360000
Screwdriver			
SD 0.6 x 3.5 x 100		10	9008330000

Dimensioned drawing

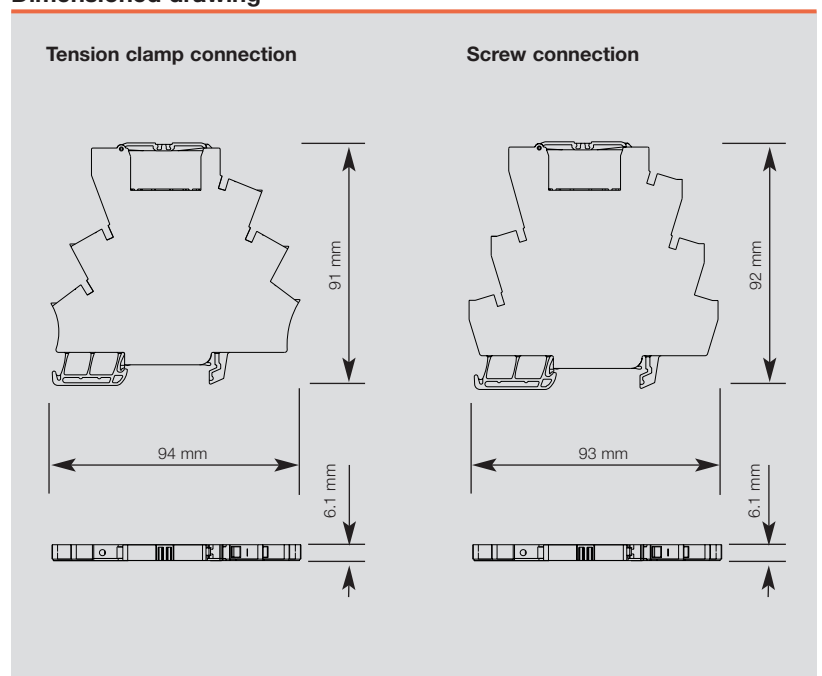

WAVESERIES

Output voltage 24 Vdc, negative switching, wide input range

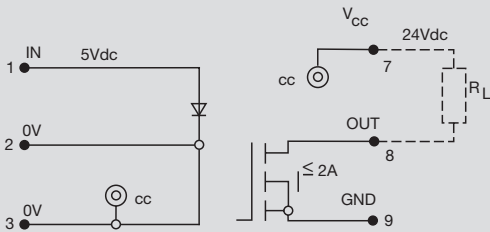

Output	
Output voltage	18 Vdc...24 Vdc...30 Vdc
Output current (max.)	2A, negative switching
Voltage drop at max. load	
Block-state curr. (closed circuit curr.)	
Switch-on delay/Switch-off delay	1 ms/6 ms
Short-circuit proof/Protective circuit	No/varistor
General data	
Ambient temp., fitted w/o distance	-25 °C...+50 °C
Ambient temp., fitted w. distance	-25 °C...+50 °C
Storage temperature	-40 °C...+85 °C
Approvals	UL/CSA
Insulation coordinates (EN 50 178)	
Standards	EN 50178
Rated voltage	300V
Rated impulse voltage	6.0kV
Creepage and clearance path input - output	=> 5.5 mm
Overvoltage category	III
Pollution severity	2
Dimensions	
Clamping range (rating- / min. / max.)	mm ² 1.5 / 0.5 / 2.5
Length x width x height	mm 72.0 / 22.5 / 92.4
Information	

Ordering data

Input

Rated voltage
Rated current
Power rating
Auxiliary voltage
Status indicator

5VDC

4.0 Vdc...5 Vdc...6.0 Vdc
7.5...19mA
30 ...114 mW
No
LED green in input

Ordering data

Complete module

Screw connection Type
Order No.
Tension clamp connection Type
Order No.

WOS1 5VDC
8275430000

Ordering data

Spare relay, pluggable

Type
Order No.

Information

K

WAVESERIES

Output voltage 5-48 Vdc



Optocoupler

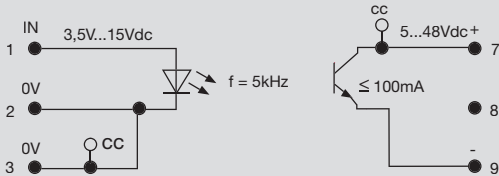

Output	
Output voltage	5 Vdc...48 Vdc
Output current (max.)	100 mA
Voltage drop at max. load	
Block-state curr. (closed circuit curr.)	
Switch-on delay/Switch-off delay	8 ms/35 ms
Short-circuit proof/Protective circuit	No/varistor, integral freewheeling diode
General data	
Ambient temp., fitted w/o distance	-25 °C...+60 °C
Ambient temp., fitted w. distance	-25 °C...+60 °C
Storage temperature	-40 °C...+85 °C
Approvals	UL/CSA
Insulation coordinates (EN 50 178)	
Standards	EN 50178
Rated voltage	300V
Rated impulse voltage	6.0kV
Creepage and clearance path input - output	=> 5.5 mm
Overvoltage category	III
Pollution severity	2
Dimensions	
Clamping range (rating- / min. / max.)	mm ² 1.5 / 0.5 / 2.5
Length x width x height	mm 72.0 / 22.5 / 92.4
Information	

Ordering data

Input		3.5-15VDC 5KHZ			
Rated voltage		3.5 Vdc...15 Vdc			
Rated current		10...25mA			
Power rating		32 ... 375 mW			
Auxiliary voltage		No			
Status indicator		LED green in input			

Ordering data Complete module

Screw connection	Type	WOS1 3.5-15VDC 5KHZ			
	Order No.	8275390000			
Tension clamp connection	Type				
	Order No.				

Ordering data Spare relay, pluggable

	Type				
	Order No.				

Information

--	--	--	--	--	--

Articles with coloured order number are kept permanently in stock at the central warehouse in Germany. Delivery times see page X.2

K

WAVESERIES

Output voltage 24 Vdc, 0.5 A,
short-circuit proof

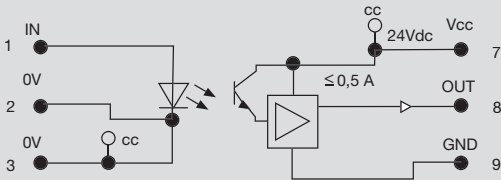
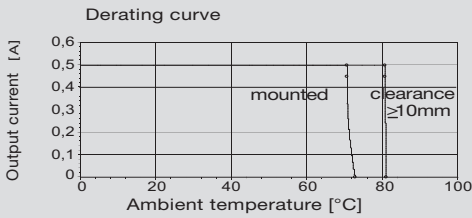

Output	
Output voltage	12 Vdc...24 Vdc...28 Vdc
Output current (max.)	500 mA
Voltage drop at max. load	
Block-state curr. (closed circuit curr.)	
Switch-on delay/Switch-off delay	approx. 10 ms/approx. 20 ms
Short-circuit proof/Protective circuit	Yes/ max. 96 h/varistor, polarity reversal protection
General data	
Ambient temp., fitted w/o distance	-25 °C...+60 °C
Ambient temp., fitted w. distance	-25 °C...+60 °C
Storage temperature	-40 °C...+85 °C
Approvals	UL/CSA
Insulation coordinates (EN 50 178)	
Standards	EN 50178
Rated voltage	300V
Rated impulse voltage	6.0kV
Creepage and clearance path input - output	=> 5.5 mm
Overvoltage category	III
Pollution severity	2
Dimensions	
Clamping range (rating- / min. / max.)	mm ² 1.5 / 0.5 / 2.5
Length x width x height	mm 72.0 / 22.5 / 92.4
Information	

K

Ordering data

Input

Rated voltage
Rated current
Power rating
Auxiliary voltage
Status indicator

12VUC/24VDC 0.5A

10 Vdc...12 Vdc...14 Vdc
15mA ac/12mA dc
0.18 VA / 0.14 W
No
LED green in output

15-60VDC 1KHZ

15 Vdc...60 Vdc
1.4...4.1mA
21 ... 246 mW
No
LED green in output

115VUC/24VDC 0.5A

115 Vuc, max. 130 Vuc
2.9mA ac/3.1mA dc
0.16 VA / 0.23 W
No
LED green in output

230VUC/24VDC 0.5A

230 Vuc, max. 250 Vuc
11.5mA ac/1.8mA dc
2.6 VA / 0.4 W
No
LED green in output

Ordering data Complete module

Screw connection Type
Order No.
Tension clamp connection Type
Order No.

12VUC/24VDC 0.5A	15-60VDC 1KHZ	115VUC/24VDC 0.5A	230VUC/24VDC 0.5A
Type	Type	Type	Type
WOS1 12VUC	WOS1 15-60VDC 1KHZ	WOS1 115VUC	WOS1 230VUC
8275500000	8237730000	8235180000	8275380000
Type	Type	Type	Type

Ordering data Spare relay, pluggable

Type
Order No.

12VUC/24VDC 0.5A	15-60VDC 1KHZ	115VUC/24VDC 0.5A	230VUC/24VDC 0.5A
Type	Type	Type	Type

Information

12VUC/24VDC 0.5A	15-60VDC 1KHZ	115VUC/24VDC 0.5A	230VUC/24VDC 0.5A

WAVESERIES

Output voltage 24 Vdc, 5 A,
short-circuit proof

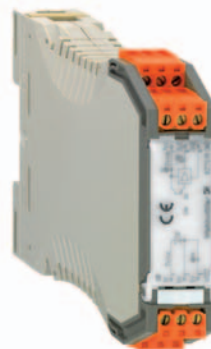

Optocoupler

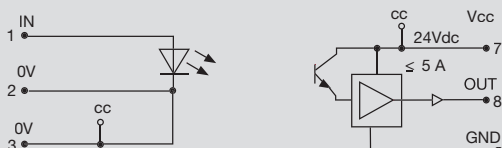
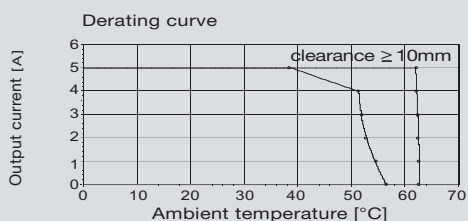

Output			
Output voltage	19.2 Vdc...24 Vdc...28.8 Vdc		
Output current (max.)	5 A		
Voltage drop at max. load			
Block-state curr. (closed circuit curr.)			
Switch-on delay/Switch-off delay	approx. 8 ms/25 ms		
Short-circuit proof/Protective circuit	Yes/ max. 96 h/varistor, polarity reversal protection		
General data			
Ambient temp., fitted w/o distance	-25 °C...+50 °C		
Ambient temp., fitted w. distance	-25 °C...+50 °C		
Storage temperature	-40 °C...+85 °C		
Approvals	UL/CSA		
Insulation coordinates (EN 50 178)			
Standards	EN 50178		
Rated voltage	300V		
Rated impulse voltage	6.0kV		
Creepage and clearance path input - output	=> 5.5 mm		
Overvoltage category	III		
Pollution severity	2		
Dimensions			
Clamping range (rating- / min. / max.)	mm ²	Screw connection	Tension clamp connection
Length x width x height	mm	1.5 / 0.5 / 2.5	92.4 / 22.5 / 112.4
Information			

Ordering data

Input	24VUC/24VDC 5A	115VUC/24VDC 5A	230VUC/24VDC 5A	
Rated voltage	24 Vuc +/- 10 %	115 Vuc, max. 130 Vuc	230 Vuc, max. 250 Vuc	
Rated current	16.3mA ac/13.5mA dc	3.1mA ac/2.8mA dc	12mA ac/1.8mA dc	
Power rating	0.39 VA / 0.32 W	0.35 VA / 0.32 W	2.7 VA / 0.4W	
Auxiliary voltage	No	No	No	
Status indicator	LED green in output	LED green in output	LED green in output	

K

Ordering data	24VUC/24VDC 5A	115VUC/24VDC 5A	230VUC/24VDC 5A	
Complete module				
Screw connection	Type			
	Order No.			
Tension clamp connection	Type			
	Order No.			
Spare relay, pluggable				
	Type			
	Order No.			
Information				

Articles with coloured order number are kept permanently in stock at the central warehouse in Germany.
Delivery times see page X.2

WAVESERIES

Output voltage 230 Vac, 3.5 A

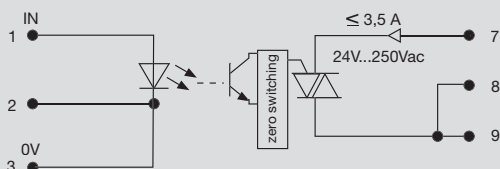
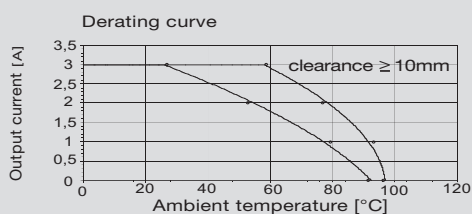

Output	
Output voltage	24 Vac...250 Vac
Output current (max.)	3.5 A
Voltage drop at max. load	
Block-state curr. (closed circuit curr.)	
Switch-on delay/Switch-off delay	max. 20 ms/max. 20 ms
Short-circuit proof/Protective circuit	No/RC-combination with resistor
General data	
Ambient temp., fitted w/o distance	-25 °C...+50 °C
Ambient temp., fitted w. distance	-25 °C...+50 °C
Storage temperature	-40 °C...+85 °C
Approvals	UL/CSA
Insulation coordinates (EN 50 178)	
Standards	EN 50178
Rated voltage	300V
Rated impulse voltage	6.0kV
Creepage and clearance path input - output	=> 5.5 mm
Overvoltage category	III
Pollution severity	2
Dimensions	
Clamping range (rating- / min. / max.)	mm ² 1.5 / 0.5 / 2.5
Length x width x height	mm 92.4 / 22.5 / 112.4
Information	

Ordering data

Input	15-60VUC/24VDC 5A	115VUC/230VAC 3.5A	230VUC/230VAC 3.5A	
Rated voltage	15 Vuc...60 Vac/ 66 Vdc	115 Vuc, max. 130 Vuc	230 Vuc, max. 250 Vuc	
Rated current	3.3...5.3mA ac/3.8...5.6mA dc	3.8mA ac/7.2mA dc	11.8mA ac/3.3mA dc	
Power rating	0.31 VA / 0.33 W	0.44 VA / 0.82 W	2.7 VA / 0.75W	
Auxiliary voltage	No	No	No	
Status indicator	LED green in input	LED green in input	LED green in input	

K

Ordering data				
Complete module				
Screw connection	Type	WOS2 15-60VAC 66VDC	WOS2 115VUC	WOS2 230VUC
	Order No.	8275440000	8259950000	8275400000
Tension clamp connection	Type			
	Order No.			
Spare relay, pluggable	Type			
	Order No.			
Information				

WAVESERIES

Output volt. 24 Vdc, 0.5 A,
short-circuit proof, 4 channels



Optocoupler

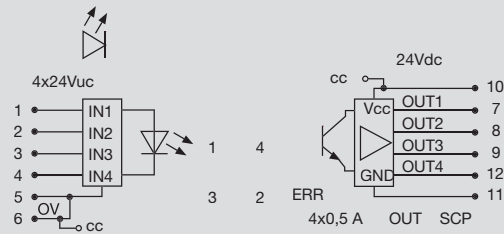
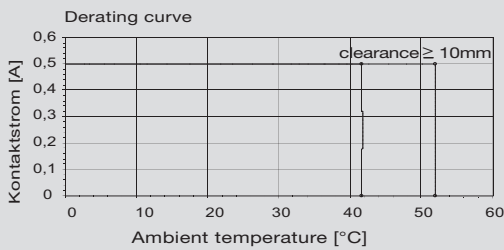

Output	
Output voltage	12 Vdc...24 Vdc...28 Vdc
Output current (max.)	0.5 A per channel
Voltage drop at max. load	
Block-state curr. (closed circuit curr.)	
Switch-on delay/Switch-off delay	<20 ms/<50 ms
Short-circuit proof/Protective circuit	Yes/varistor, polarity reversal protection
General data	
Ambient temp., fitted w/o distance	-25 °C...+50 °C
Ambient temp., fitted w. distance	-25 °C...+50 °C
Storage temperature	-40 °C...+85 °C
Approvals	UL/CSA
Insulation coordinates (EN 50 178)	
Standards	EN 50178
Rated voltage	150V
Rated impulse voltage	6.0kV
Creepage and clearance path input - output	=> 3 mm
Overvoltage category	III
Pollution severity	2
Dimensions	
Clamping range (rating- / min. / max.)	mm ² 1.5 / 0.5 / 2.5
Length x width x height	mm 92.4 / 22.5 / 112.4
Information	

Ordering data

Input

Rated voltage
Rated current
Power rating
Auxiliary voltage
Status indicator

24VUC/24VDC 0.5A

18 Vuc...30 Vuc
2.8mA ac/3.7mA dc
0.4 VA / 0.3 W
No
LED green in output

115VUC/24VDC 0.5A

115 Vuc, max. 130 Vuc
1.4mA ac/2mA dc
0.16 VA / 0.23 W
No
LED green in output

230VUC/24VDC 0.5A

230 Vuc, max. 250 Vuc
1.4mA ac/2mA dc
0.16 VA / 0.23 W
No
LED green in output

Ordering data

Complete module

Screw connection Type
Order No.
Tension clamp connection Type
Order No.

WOS2 24VUC 4C
8237720000

WOS2 115VUC 4C
8275360000

WOS2 230VUC 4C
8275340000

Ordering data

Spare relay, pluggable

Type
Order No.

Information

Articles with coloured order number are kept permanently in stock at the central warehouse in Germany.
Delivery times see page X.2

WAVESERIES

For high switching frequency up to 100kHz

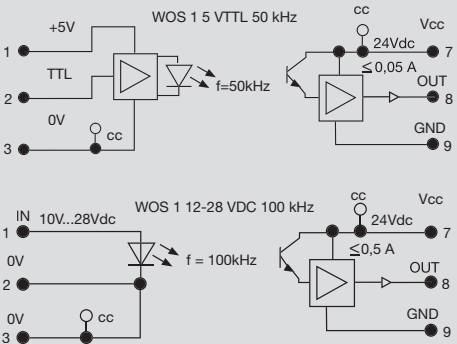
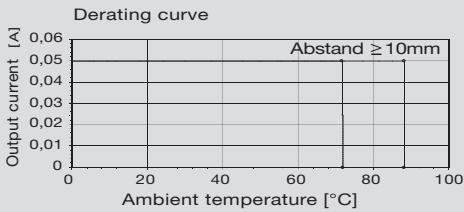

Output		
Output voltage	21.6 Vdc...24 Vdc...26.4 Vdc	
Output current (max.)	50 mA	
Voltage drop at max. load		
Block-state curr. (closed circuit curr.)		
Switch-on delay/Switch-off delay	1 μs/7 μs	
Short-circuit proof/Protective circuit	No/varistor, polarity reversal protection	
General data		
Ambient temp., fitted w/o distance	-25 °C...+60 °C	
Ambient temp., fitted w. distance	-25 °C...+60 °C	
Storage temperature	-40 °C...+85 °C	
Approvals	UL/CSA	
Insulation coordinates (EN 50 178)		
Standards	EN 50178	
Rated voltage	300V	
Rated impulse voltage	6.0kV	
Creepage and clearance path input - output	=> 5.5 mm	
Overvoltage category	III	
Pollution severity	2	
Dimensions		
Clamping range (rating- / min. / max.)	mm ²	1.5 / 0.5 / 2.5
Length x width x height	mm	72.0 / 22.5 / 92.4
Information		

K

Ordering data

Input

Rated voltage
Rated current
Power rating
Auxiliary voltage
Status indicator

5VTTL 50KHZ

5 V TTL
13mA
65 mW
5 V
LED green in input

12-28VDC 100KHZ

12 Vdc...28 Vdc
8mA
190 mW
No
LED green in input

Ordering data

Complete module

Screw connection Type
Order No.
Tension clamp connection Type
Order No.

WOS1 5VTTL 50KHZ
8275210000

WOS1 12-28VDC 100KHZ
8275450000

Ordering data

Spare relay, pluggable

Type
Order No.

Information

MCZ-SERIES

MiniConditioner MCZ O

Universal interface between control and sensor/actuator

Direct switching of load currents upto 2A dc

MCZ O with following features:

- Tension clamp connection technology
- Pluggable cross-connection
- Width 6mm

24 VUC

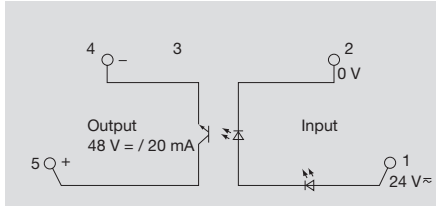
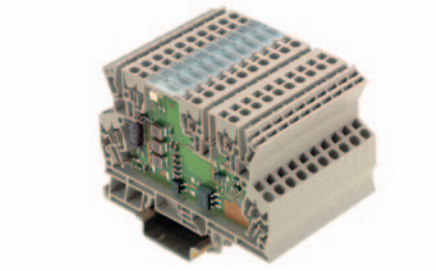

24VUC/24V 2A

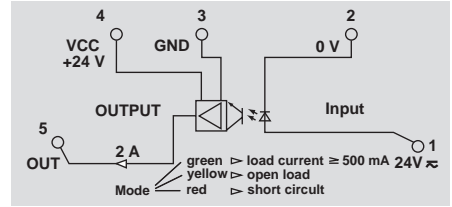

Technical data

Input

Rated voltage	24 Vuc +/- 20 %
Rated current	11mA ac/9mA dc
Power rating	230mW / 280mVA
Max. input frequency	dc: 10 Hz/ac: 5 Hz
Auxiliary voltage	No
Status indicator	LED green

Output

Output voltage	5...48Vdc
Output current (max.)	20 mA
Voltage drop at max. load	<= 1 V
Block-state curr. (closed circuit curr.)	
Switch-on delay/Switch-off delay	dc 20 ms/ ac 10 ms//ac 45ms/dc 40ms
Short-circuit proof/Protective circuit	No/integrated freewheel diode

General data

Ambient temp., fitted w. distance	-25 °C...+50 °C
Ambient temp., fitted w/o distance	-25 °C...+50 °C
Storage temperature	-40 °C...+85 °C
Approvals	CE, UL, CSA

Insulation coordinates (EN 50 178)

Standards	EN 50178
Rated voltage	300V
Rated impulse voltage	6.0kV
Creepage and clearance path input - output	>= 5.5 mm
Overtoltage category	III
Pollution severity	2

Rated voltage	24 Vuc +/- 20 %
Rated current	11mA ac/9mA dc
Power rating	230mW / 280mVA
Max. input frequency	dc: 10 Hz/ac: 5 Hz
Auxiliary voltage	No
Status indicator	LED green
Output voltage	5...48Vdc
Output current (max.)	20 mA
Voltage drop at max. load	<= 1 V
Block-state curr. (closed circuit curr.)	
Switch-on delay/Switch-off delay	dc 20 ms/ ac 10 ms//ac 45ms/dc 40ms
Short-circuit proof/Protective circuit	No/integrated freewheel diode
Ambient temp., fitted w. distance	-25 °C...+50 °C
Ambient temp., fitted w/o distance	-25 °C...+50 °C
Storage temperature	-40 °C...+85 °C
Approvals	CE, UL, CSA
Standards	EN 50178
Rated voltage	300V
Rated impulse voltage	6.0kV
Creepage and clearance path input - output	>= 5.5 mm
Overtoltage category	III
Pollution severity	2

Rated voltage	24 Vuc +/- 20 %
Rated current	13mA ac/12mA dc
Power rating	195mW / 220mVA
Max. input frequency	dc: 30 Hz/ac: 10 Hz
Auxiliary voltage	No
Status indicator	LED green
Output voltage	24 Vdc +/- 20%
Output current (max.)	2 A
Voltage drop at max. load	
Block-state curr. (closed circuit curr.)	
Switch-on delay/Switch-off delay	/
Short-circuit proof/Protective circuit	No/varistor
Ambient temp., fitted w. distance	-25 °C...+40 °C
Ambient temp., fitted w/o distance	-25 °C...+40 °C
Storage temperature	-40 °C...+60 °C
Approvals	CE, UL, CSA
Standards	EN 50178
Rated voltage	300V
Rated impulse voltage	6.0kV
Creepage and clearance path input - output	>= 5.5 mm
Overtoltage category	III
Pollution severity	2

Dimensions

Clamping range (rating- / min. / max.)	mm ²	1.50 / 0.50 / 1.50
Length x width x height	mm	91.0 x 6.0 x 64.0

Information

Tension clamp c.

CE, UL, CSA	CE, UL, CSA
Mounting on TS35	Mounting on TS35

Tension clamp c.

CE, UL, CSA	CE, UL, CSA
Mounting on TS35	Mounting on TS35

Ordering data

Connection technology	Tension clamp c.
-----------------------	------------------

Type	Qty.	Order No.
MCZ O 24VUC	10	8365940000

Type	Qty.	Order No.
MCZ O 24VUC	10	8287730000

Information

Accessories

Information	End plate AP MCZ1.5 8389030000
-------------	-----------------------------------

Information	End plate AP MCZ 8389030000
-------------	--------------------------------

MCZ-SERIES

MiniConditioner MCZ O

Universal interface between control and sensor/actuator

MCZ O with following features:

- Tension clamp connection technology
- Pluggable cross-connection
- Width 6mm

120VUC

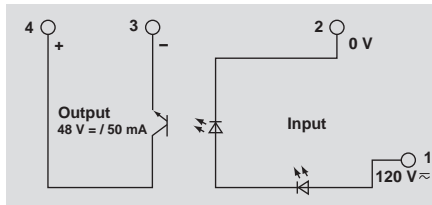
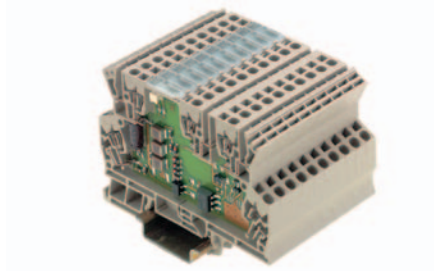

230VAC

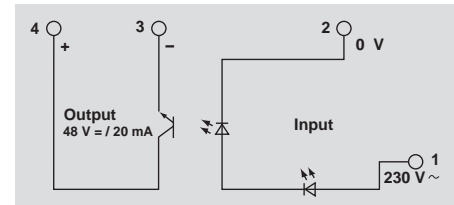
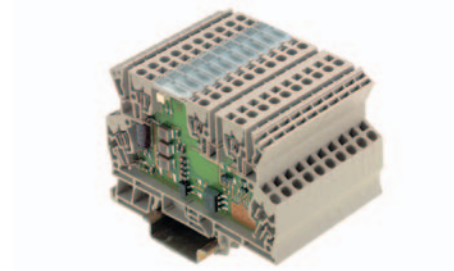

Technical data

Input

Rated voltage
Rated current
Power rating
Max. input frequency
Auxiliary voltage
Status indicator

120 V_{uc} +5/-15 %
3mA
350mW / 400mVA
Ac: 5 Hz duty factor 1:2, dc: 20 Hz duty factor 1:2
No
LED green

230 Vac +5 %/ -15 %
10 mA
2.3 VA
Ac: 5 Hz duty factor 1:2
No
LED green

Output

Output voltage
Output current (max.)
Voltage drop at max. load
Block-state curr. (closed circuit curr.)
Switch-on delay/Switch-off delay
Short-circuit proof/Protective circuit

5...48 Vdc
50 mA
< 1.6 V
0.16 mA
<= 30 ms/<= 40 ms
No/integrated freewheel diode

5...48 Vdc
20 mA
< 1.6 V
0.16 mA
<= 30 ms/<= 40 ms
No/integrated freewheel diode

General data

Ambient temp., fitted w. distance
Ambient temp., fitted w/o distance
Storage temperature
Approvals

-25 °C...+50 °C
-25 °C...+40 °C
-40 °C...+60 °C
CE, UL, CSA

-25 °C...+50 °C
-25 °C...+40 °C
-40 °C...+85 °C
CE, UL, CSA

Insulation coordinates (EN 50 178)

Standards
Rated voltage
Rated impulse voltage
Creepage and clearance path input - output
Overvoltage category
Pollution severity

EN 50178
300V
6.0kV
>= 5.5 mm
III
2

EN 50178
300V
6.0kV
>= 5.5 mm
III
2

Dimensions

Clamping range (rating- / min. / max.) mm²
Length x width x height mm

Tension clamp c.

1.50 / 0.50 / 1.50
91.0 x 6.0 x 64.0

Tension clamp c.

1.50 / 0.50 / 1.50
91.0 x 6.0 x 64.0

Information

CE, UL, CSA
Mounting on TS35

CE, UL, CSA
Mounting on TS35

Ordering data

Connection technology

Tension clamp c.

Type	Qty.	Order No.
MCZ O 120VUC	10	8421060000

Type	Qty.	Order No.
MCZ O 230VAC	10	8421380000

Information

Accessories

Information

End plate
AP MCZ 8389030000

End plate
AP MCZ 8389030000

Articles with coloured order number are kept permanently in stock at the central warehouse in Germany.
Delivery times see page X.2

MCZ-SERIES

MiniConditioner MCZ O

Module can be used as an universal interface:

- Between control and actuator, to convert signals from 24 Vdc to 5 VTTL
- Between control and actuator, to convert signals from 5 VTTL to 5...48 Vdc

24VDC/5VTTL

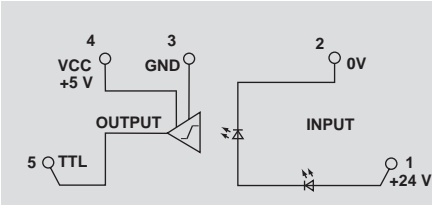
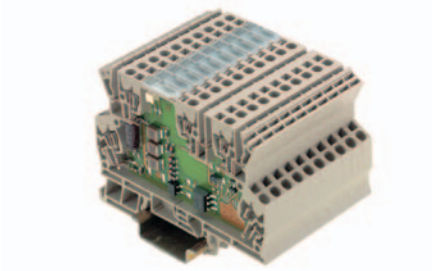

5VTTL/5...48 VDC

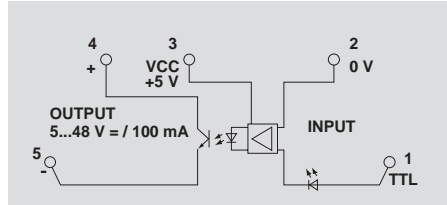
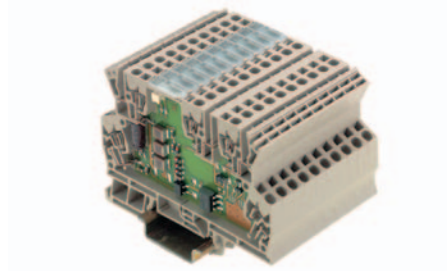

Technical data

Input

Rated voltage	24 Vdc +/- 16 %
Rated current	4.7mA
Power rating	112 mW
Max. input frequency	100 kHz duty factor 1:2, 50 kHz duty factor 1:10
Auxiliary voltage	No
Status indicator	LED green

Output

Output voltage	5 V TTL(4.75...5.25 V)
Output current (max.)	8 mA, fan out = 20 LS-TTL
Voltage drop at max. load	
Block-state curr. (closed circuit curr.)	
Switch-on delay/Switch-off delay	1 µs (at 20 Vdc)/2.5 µs (at 28 Vdc)
Short-circuit proof/Protective circuit	/diode

General data

Ambient temp., fitted w. distance	-25 °C...+50 °C
Ambient temp., fitted w/o distance	-25 °C...+40 °C
Storage temperature	-40 °C...+60 °C
Approvals	CE, UL, CSA

Insulation coordinates (EN 50 178)

Standards	EN 50178
Rated voltage	300V
Rated impulse voltage	6.0kV
Creepage and clearance path input - output	>= 5.5 mm
Overvoltage category	III
Pollution severity	2

Input

Rated voltage	5 V TTL
Rated current	1µA
Power rating	10 mW
Max. input frequency	2.4 kHz
Auxiliary voltage	5 V
Status indicator	LED green

Output

Output voltage	5...48Vdc
Output current (max.)	100 mA
Voltage drop at max. load	<= 1.8
Block-state curr. (closed circuit curr.)	
Switch-on delay/Switch-off delay	/
Short-circuit proof/Protective circuit	/diode

General data

Ambient temp., fitted w. distance	-25 °C...+50 °C
Ambient temp., fitted w/o distance	-25 °C...+50 °C
Storage temperature	-40 °C...+85 °C
Approvals	CE, UL, CSA

Insulation coordinates (EN 50 178)

Standards	EN 50178
Rated voltage	300V
Rated impulse voltage	6.0kV
Creepage and clearance path input - output	>= 5.5 mm
Overvoltage category	III
Pollution severity	2

Dimensions

Clamping range (rating- / min. / max.)	mm²
Length x width x height	mm

Information

Tension clamp c.

1.50 / 0.50 / 1.50
91.0 x 6.0 x 64.0

CE, UL, CSA
Mounting on TS35

Tension clamp c.

1.50 / 0.50 / 1.50
91.0 x 6.0 x 64.0

CE, UL, CSA
Mounting on TS35

Ordering data

Connection technology

Tension clamp c.

Type	Qty.	Order No.
MCZ O 24VDC	10	8324610000

Type	Qty.	Order No.
MCZ O 5VTTL	10	8398940000

Information

Accessories

Information

End plate
AP MCZ 8389030000

End plate
AP MCZ 8389030000

DK-SERIES

Minicoupler DKO

- Coupling of digital sensor-/actuator signals between PLC and process
- Low-cost solution for adaption of level and potential
- Low input power
- Screw connection technology
- 6 mm width
- Mounting on TS35

5VDC

5VTTL

12VDC 10 KHZ

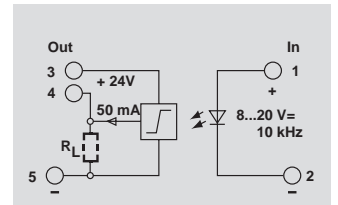
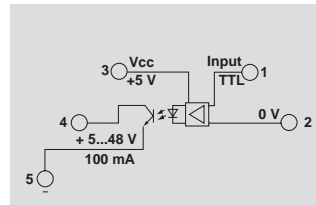
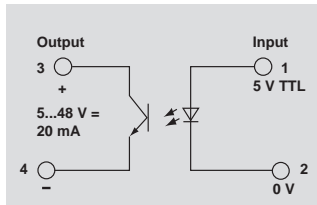
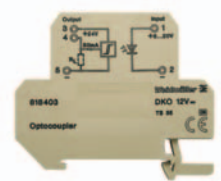
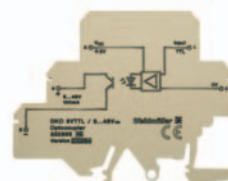

Technical data

Input

Rated voltage
Rated current
Power rating
Max. input frequency
Auxiliary voltage
Status indicator

5 Vdc +/- 5 %
10 mA
50 mW
20 Hz
No
LED green

5 V TTL
1 μ A
50 μ W
3 kHz
5 V
LED green

12 Vdc +/- 20 %
11 mA
max. 130 mW
max. 10 kHz
No
LED green

Output

Output voltage
Output current (max.)
Voltage drop at max. load
Block-state curr. (closed circuit curr.)
Switch-on delay/Switch-off delay
Short-circuit proof/Protective circuit

5...48 Vdc
20 mA
< 1.6 V
50 μ A
<= 15 μ s / <= 70 μ s
No/diode

5...48 Vdc
100 mA
<= 1.6 V
<= 50 μ A
approx. 27 μ s / approx. 35 μ s
No/diode

24 Vdc +/- 10%
50 mA
< 1 V
<= 50 μ A
1 μ s / 2.5 μ s
No/diode

General data

Ambient temp., fitted w. distance
Ambient temp., fitted w/o distance
Storage temperature
Approvals

-25 °C...+50 °C
-25 °C...+40 °C
-40 °C...+85 °C
CE

-25 °C...+50 °C
-25 °C...+40 °C
-40 °C...+85 °C
CE

-25 °C...+50 °C
-25 °C...+40 °C
-40 °C...+85 °C
CE

Insulation coordinates (EN 50 178)

Standards
Rated voltage
Rated impulse voltage
Creepage and clearance path input - output
Overvoltage category
Pollution severity

EN 50178
150V
4.0kV
>= 4 mm
IV
2

EN 50178
300V
6.0kV
>= 5.5 mm
IV
2

EN 50178
300V
6.0kV
>= 5.5 mm
IV
2

Dimensions

Clamping range (rating- / min. / max.) mm²
Length x width x height mm

Screw connection

4 / 0.50 / 4
65.0 x 6.0 x 57.0

Screw connection

4 / 0.50 / 4
77.0 x 6.0 x 62.0

Screw connection

4 / 0.50 / 4
65.0 x 12.0 x 57.0

Information

Ordering data

Connection technology

Screw connection

Type	(Qty.=10)	Order No.
DKO 35 5VDC		8018630000

Type	(Qty.=10)	Order No.
DKO DK5 5VTTL		8228650000

Type	(Qty.=10)	Order No.
DKO 35 12VDC 10KHZ		8184030000

Information

Input bottom

Input bottom

Input bottom

Accessories

Information

End plate
AP DK4 0687560000

End plate
AP DK5 8268870000

End plate
AP DK4 0687560000

DK-SERIES

Minicoupler DKO

- Coupling of digital sensor-/actuator signals between PLC and process
- Low-cost solution for adaption of level and potential
- Low input power
- Screw connection technology
- 6 mm width
- Mounting on TS35

24VUC

24VDC 3KHZ

24VDC 3KHZ

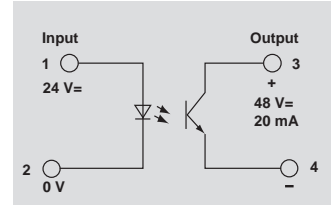
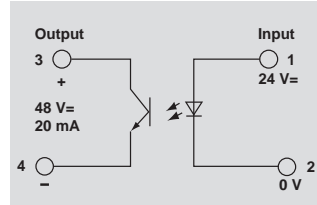
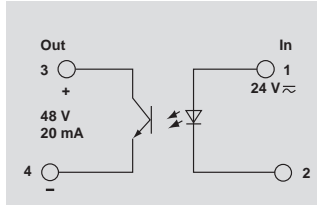

Technical data

Input

Rated voltage
Rated current
Power rating
Max. input frequency
Auxiliary voltage
Status indicator

24 V_{uc} +/- 10 %
11.4 mA ac / 9.6 mA dc
280 mVA / 230 mW
10 Hz at dc
No
LED green

24 V_{dc} +/- 10 %
<= 15 mA
max. 360 mW
3 kHz
No
LED green

24 V_{dc} +/- 10 %
<= 15 mA
max. 360 mW
3 kHz
No
LED green

Output

Output voltage
Output current (max.)
Voltage drop at max. load
Block-state curr. (closed circuit curr.)
Switch-on delay/Switch-off delay
Short-circuit proof/Protective circuit

5...48 V_{dc}
20 mA
<= 1 V
<= 50 μA
<= 15 ms at dc / <= 25 ms at dc
No/diode

5...48 V_{dc}
20 mA
<= 900 mV
0.16 mA
approx. 50 μs / approx. 80 μs
No/diode

5...48 V_{dc}
20 mA
<= 900 mV
50 μA
approx. 50 μs / approx. 80 μs
No/diode

General data

Ambient temp., fitted w. distance
Ambient temp., fitted w/o distance
Storage temperature
Approvals

-25 °C...+50 °C
-25 °C...+40 °C
-40 °C...+85 °C
CE

-25 °C...+50 °C
-25 °C...+40 °C
-40 °C...+85 °C
CE

-25 °C...+50 °C
-25 °C...+40 °C
-40 °C...+85 °C
CE

Insulation coordinates (EN 50 178)

Standards
Rated voltage
Rated impulse voltage
Creepage and clearance path input - output
Overvoltage category
Pollution severity

EN 50178
300V
4.0kV
>= 4 mm
III
2

EN 50178
300V
4.0kV
>= 4 mm
III
2

EN 50178
300V
4.0kV
>= 4 mm
III
2

Dimensions

Clamping range (rating- / min. / max.) mm²
Length x width x height mm

Screw connection

4 / 0.50 / 4
65.0 x 6.0 x 57.0

Screw connection

4 / 0.50 / 4
65.0 x 6.0 x 57.0

Screw connection

4 / 0.50 / 4
65.0 x 6.0 x 57.0

Information

Ordering data

Connection technology

Screw connection

Type	(Qty.=10)	Order No.
DKO 35 24VUC		8008150000

Type	(Qty.=10)	Order No.
DKO 35 24VDC 3KHZ E.U		8028300000

Type	(Qty.=10)	Order No.
DKO 35 24VDC 3KHZ E:O		8215640000

Information

Input bottom

Input bottom

Input top

Accessories

Information

End plate
AP DK4 0687560000

End plate
AP DK4 0687560000

End plate
AP DK4 0687560000

Articles with coloured order number are kept permanently in stock at the central warehouse in Germany.
Delivery times see page X.2

DK-SERIES

Minicoupler DKO

- Coupling of digital sensor-/actuator signals between PLC and process
- Low-cost solution for adaption of level and potential
- Low input power
- Screw connection technology
- 6 mm width
- Mounting on TS35

24VDC 3KHZ

24VDC 100Hz

24VDC 100Hz

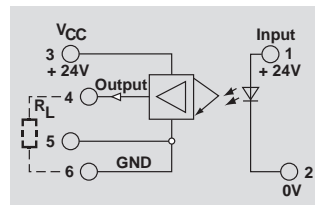
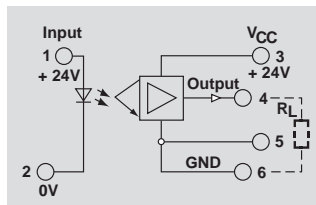
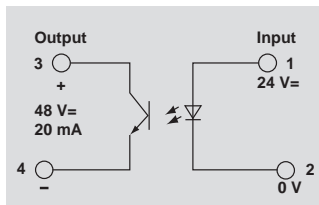

Technical data

Input	24 Vdc +/- 10 %	24 Vdc +/- 10 %	24 Vdc +/- 10 %
Rated voltage	24 Vdc +/- 10 %	24 Vdc +/- 10 %	24 Vdc +/- 10 %
Rated current	8.5 mA	12 mA	12 mA
Power rating	max. 204 mW	max. 290 mW	max. 290 mW
Max. input frequency	3 kHz	100 Hz	100 Hz
Auxiliary voltage	No	No	No
Status indicator	LED green	LED green	LED green
Output			
Output voltage	5...48 Vdc	24 Vdc +/- 10%	24 Vdc +/- 10%
Output current (max.)	20 mA	2 A	2 A
Voltage drop at max. load	<= 900 mV		
Block-state curr. (closed circuit curr.)	50 µA		
Switch-on delay/Switch-off delay	approx. 50 µs/approx. 80 µs	2 ms/7 ms	2 ms/7 ms
Short-circuit proof/Protective circuit	No/diode	No/varistor	No/diode
General data			
Ambient temp., fitted w. distance	-25 °C...+50 °C	-25 °C...+50 °C	-25 °C...+50 °C
Ambient temp., fitted w/o distance	-25 °C...+40 °C	-25 °C...+40 °C	-25 °C...+40 °C
Storage temperature	-40 °C...+85 °C	-40 °C...+85 °C	-40 °C...+85 °C
Approvals	CE	CE	CE
Insulation coordinates (EN 50 178)			
Standards	EN 50178	EN 50178	EN 50178
Rated voltage	300V	300V	300V
Rated impulse voltage	4.0kV	4.0kV	4.0kV
Creepage and clearance path input - output	>= 4 mm	>= 3 mm	>= 3 mm
Overvoltage category	III	III	III
Pollution severity	2	2	2

Dimensions

Clamping range (rating- / min. / max.) mm²
 Length x width x height mm

Screw connection

4 / 0.50 / 4
 65.0 x 6.0 x 57.0

Screw connection

4 / 0.50 / 4
 65.0 x 12.0 x 57.0

Screw connection

4 / 0.50 / 4
 65.0 x 12.0 x 57.0

Information

Ordering data

Connection technology	Type	(Qty.=10)	Order No.	Type	(Qty.=10)	Order No.	Type	(Qty.=10)	Order No.
Screw connection	DKO 35 24VDC 3KHZ E:U		8248790000	DKO 35 24VDC E:U		8181990000	DKO 35 24VDC E:O		8215600000
Information	Input bottom			Input bottom			Input top		

Accessories

Information	End plate	AP DK4	0687560000	End plate	AP DK4	0687560000	End plate	AP DK4	0687560000

DK-SERIES

Minicoupler DKO

- Coupling of digital sensor-/actuator signals between PLC and process
- Low-cost solution for adaption of level and potential
- Low input power
- Screw connection technology
- 6 mm width
- Mounting on TS35

24VDC 200Hz

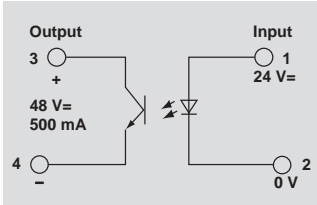

24VDC 200Hz

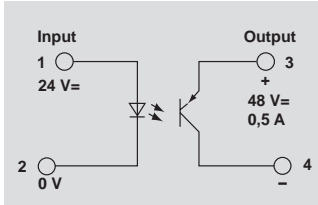

24VDC 50KHZ

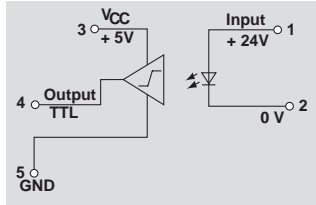
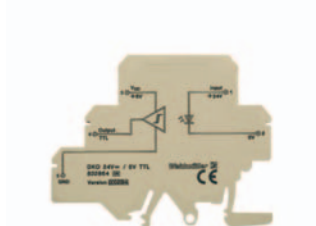

Technical data

Input

Rated voltage
Rated current
Power rating
Max. input frequency
Auxiliary voltage
Status indicator

24 Vdc +/- 10 %
6 mA
145 mW
200 Hz
No
LED green

24 Vdc +/- 10 %
6 mA
max. 145 mW
200Hz
No
LED green

24 Vdc +/- 10 %
4.7 mA
max. 112 mW
100kHz
No
LED green

Output

Output voltage
Output current (max.)
Voltage drop at max. load
Block-state curr. (closed circuit curr.)
Switch-on delay/Switch-off delay
Short-circuit proof/Protective circuit

5...48 Vdc
500 mA
< = 800 mV
approx. 40 µs/approx. 65 µs
No/diode

5...48 Vdc
500 mA
< = 800 mV
< = 10µA
approx. 40 µs/approx. 65 µs
No/diode

5 VTTL
8 mA, fan out=20 LS-TTL
1 µs/2.5 µs
No/diode

General data

Ambient temp., fitted w. distance
Ambient temp., fitted w/o distance
Storage temperature
Approvals

-25 °C...+50 °C
-25 °C...+40 °C
-40 °C...+85 °C
CE

-25 °C...+50 °C
-25 °C...+40 °C
-40 °C...+85 °C
CE

-25 °C...+50 °C
-25 °C...+40 °C
-25 °C...+85 °C
CE

Insulation coordinates (EN 50 178)

Standards
Rated voltage
Rated impulse voltage
Creepage and clearance path input - output
Overvoltage category
Pollution severity

EN 50178
300V
4.0kV
>= 4 mm
III
2

EN 50178
300V
4.0kV
>= 4 mm
III
2

EN 50178
300V
4.0kV
>= 5.5 mm
III
2

Dimensions

Clamping range (rating- / min. / max.) mm²
Length x width x height mm

Screw connection

4 / 0.50 / 4
65.0 x 6.0 x 57.0

Screw connection

4 / 0.50 / 4
65.0 x 6.0 x 57.0

Screw connection

4 / 0.50 / 4
77.0 x 6.0 x 62.0

Information

Ordering data

Connection technology

Screw connection

Type	(Qty.=10)	Order No.
DKO 35 24VDC E:U		8019590000

Type	(Qty.=10)	Order No.
DKO 35 24VDC E:O		8215630000

Type	(Qty.=10)	Order No.
DKO DK5 24VDC 50KHZ		8228640000

Information

Input bottom

Input top

Input top

Accessories

Information

End plate
AP DK4 0687560000

End plate
AP DK4 0687560000

End plate
AP DK5 8268870000

Articles with coloured order number are kept permanently in stock at the central warehouse in Germany.
Delivery times see page X.2

DK-SERIES

Minicoupler DKO

- Coupling of digital sensor-/actuator signals between PLC and process
- Low-cost solution for adaption of level and potential
- Low input power
- Screw connection technology
- 6 mm width
- Mounting on TS35

24VUC

115VUC

230VUC

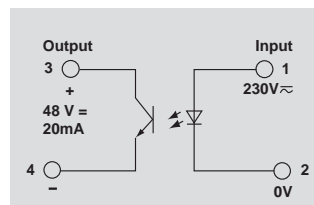
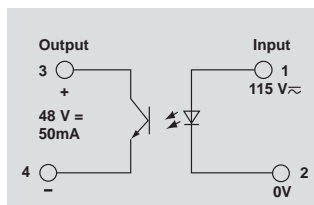
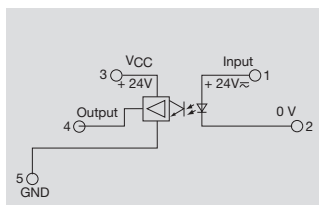

Technical data

Input

Rated voltage	24 Vuc +/- 20 %
Rated current	13 mA ac / 12 mA dc
Power rating	max.: 220 mVA / 195 mW
Max. input frequency	<=; 10 Hz
Auxiliary voltage	No
Status indicator	LED green

Output

Output voltage	24 Vdc +/- 20%
Output current (max.)	2 A
Voltage drop at max. load	
Block-state curr. (closed circuit curr.)	
Switch-on delay/Switch-off delay	2 ms/7 ms
Short-circuit proof/Protective circuit	No/

General data

Ambient temp., fitted w. distance	-25 °C...+50 °C
Ambient temp., fitted w/o distance	-25 °C...+40 °C
Storage temperature	-40 °C...+85 °C
Approvals	CE

Insulation coordinates (EN 50 178)

Standards	EN 50178
Rated voltage	300V
Rated impulse voltage	6.0kV
Creepage and clearance path input - output	>= 5.5 mm
Overvoltage category	IV
Pollution severity	2

Dimensions

Clamping range (rating- / min. / max.)	mm ²
Length x width x height	mm

Information

Screw connection

4 / 0.50 / 4
77.0 x 6.0 x 62.0

Screw connection

4 / 0.50 / 4
65.0 x 6.0 x 57.0

Screw connection

4 / 0.50 / 4
65.0 x 6.0 x 57.0

Ordering data

Connection technology

Screw connection

Type	(Qty.=10)	Order No.
DKO DK5 24VUC		8228630000

Type	(Qty.=10)	Order No.
DKO 35 115VUC		8077860000

Type	(Qty.=10)	Order No.
DKO 35 230VUC		8008160000

Information

Input bottom

Input bottom

Input bottom

Accessories

Information

End plate	AP DK5	8268870000
-----------	--------	------------

End plate	AP DK4	0687560000
-----------	--------	------------

End plate	AP DK4	0687560000
-----------	--------	------------

EG-SERIES

EG 7

- Combination foot for TS15, TS32 or TS35
- Optional pluggable on clip-in base RS EG7
- Width 10 mm
- Protective separation according to VDE 0884

5VDC

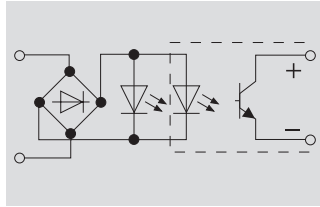

12VUC

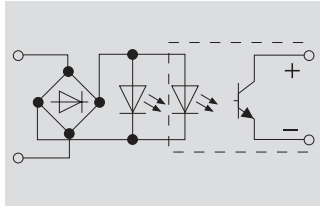

24VUC

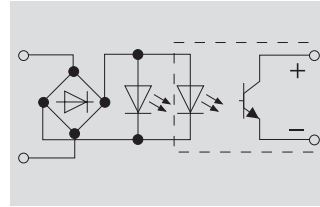
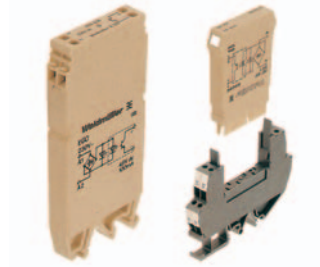

Technical data

Input

Rated voltage	5 Vdc +/- 20 %
Rated current	6.8 mA
Power rating	40 mW
Max. input frequency	15Hz
Auxiliary voltage	No
Status indicator	LED green

Output

Output voltage	5...48Vdc
Output current (max.)	100 mA
Voltage drop at max. load	< 1.5 V
Block-state curr. (closed circuit curr.)	< =50 µA
Switch-on delay/Switch-off delay	6ms/12ms
Short-circuit proof/Protective circuit	No/integrated freewheel diode

General data

Ambient temp., fitted w. distance	-25 °C...+60 °C
Ambient temp., fitted w/o distance	-25 °C...+60 °C
Storage temperature	-40 °C...+60 °C
Approvals	CE

Insulation coordinates (EN 50 178)

Standards	EN 50178
Rated voltage	300V
Rated impulse voltage	6.0kV
Creepage and clearance path input - output	>= 5.5 mm
Overvoltage category	III
Pollution severity	2

Rated voltage	12 Vuc +/- 20 %
Rated current	33mA ac/30mA dc
Power rating	40 mW / 50 mVA
Max. input frequency	15Hz
Auxiliary voltage	No
Status indicator	LED green

Output voltage	5...48Vdc
Output current (max.)	100 mA
Voltage drop at max. load	< 1.5 V
Block-state curr. (closed circuit curr.)	< =50 µA
Switch-on delay/Switch-off delay	6ms/12ms
Short-circuit proof/Protective circuit	No/integrated freewheel diode

Ambient temp., fitted w. distance	-25 °C...+60 °C
Ambient temp., fitted w/o distance	-25 °C...+60 °C
Storage temperature	-40 °C...+60 °C
Approvals	CE

Standards	EN 50178
Rated voltage	300V
Rated impulse voltage	6.0kV
Creepage and clearance path input - output	>= 5.5 mm
Overvoltage category	III
Pollution severity	2

Rated voltage	24 Vuc +/- 20 %
Rated current	3.4 mA dc/2.8 mA ac
Power rating	70 mW / 90 mVA
Max. input frequency	15Hz
Auxiliary voltage	No
Status indicator	LED green

Output voltage	5...48Vdc
Output current (max.)	100 mA
Voltage drop at max. load	< 1.5 V
Block-state curr. (closed circuit curr.)	< =50 µA
Switch-on delay/Switch-off delay	5ms/15ms
Short-circuit proof/Protective circuit	No/integrated freewheel diode

Ambient temp., fitted w. distance	-25 °C...+60 °C
Ambient temp., fitted w/o distance	-25 °C...+60 °C
Storage temperature	-40 °C...+60 °C
Approvals	CE

Standards	EN 50178
Rated voltage	300V
Rated impulse voltage	6.0kV
Creepage and clearance path input - output	>= 5.5 mm
Overvoltage category	III
Pollution severity	2

Rated voltage	5 Vdc +/- 20 %
Rated current	6.8 mA
Power rating	40 mW
Max. input frequency	15Hz
Auxiliary voltage	No
Status indicator	LED green

Output voltage	5...48Vdc
Output current (max.)	100 mA
Voltage drop at max. load	< 1.5 V
Block-state curr. (closed circuit curr.)	< =50 µA
Switch-on delay/Switch-off delay	6ms/12ms
Short-circuit proof/Protective circuit	No/integrated freewheel diode

Ambient temp., fitted w. distance	-25 °C...+60 °C
Ambient temp., fitted w/o distance	-25 °C...+60 °C
Storage temperature	-40 °C...+60 °C
Approvals	CE

Standards	EN 50178
Rated voltage	300V
Rated impulse voltage	6.0kV
Creepage and clearance path input - output	>= 5.5 mm
Overvoltage category	III
Pollution severity	2

Dimensions

Clamping range (rating- / min. / max.)	mm ²
Length x width x height	mm

Information

Complete module	Pluggable
1.50 / 0.50 / 1.50	2.50 / 0.50 / 2.50
44.0 x 10.0 x 96.0	95.0 x 10.0 x 99.0
Dimensions pluggable opto-coupler incl. locking socket RS EG7	

Complete module	Pluggable
1.50 / 0.50 / 1.50	2.50 / 0.50 / 2.50
44.0 x 10.0 x 96.0	95.0 x 10.0 x 99.0
Dimensions pluggable opto-coupler incl. locking socket RS EG7	

Complete module	Pluggable
1.50 / 0.50 / 1.50	2.50 / 0.50 / 2.50
44.0 x 10.0 x 96.0	95.0 x 10.0 x 99.0
Dimensions pluggable opto-coupler incl. locking socket RS EG7	

Ordering data

Article description	Type	(Qty.=10)	Order No.
Complete module Pluggable	EGO EG7 5VDC K-FU		8092490000
	OST EG7 5VDC		8234560000

Information

Type	(Qty.=10)	Order No.
EGO EG7 12VUC K-FU		8092510000
OST EG7 12VUC		8234570000

Information

Type	(Qty.=10)	Order No.
EGO EG7 24VUC K-FU		8092530000
OST EG7 24VUC		8234580000

Information

Information

Accessories

Locking socket RS EG7 8193830000

Locking socket RS EG7 8193830000

Locking socket RS EG7 8193830000

Locking socket RS EG7 8193830000

EG-SERIES

EG 7

- Combination foot for TS15, TS32 or TS35
- Optional pluggable on clip-in base RS EG7
- Width 10 mm
- Protective separation according to VDE 0884

48VUC

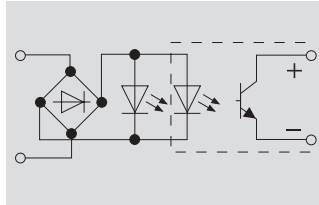
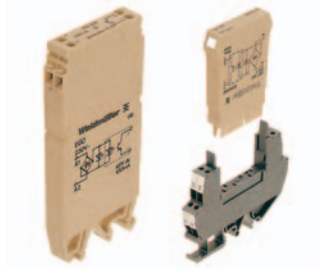

115VUC

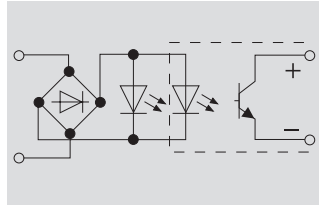

230VAC

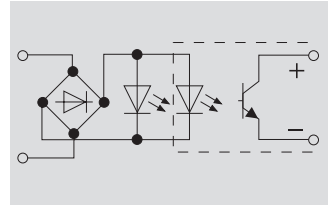

Technical data

Input

Rated voltage	48 Vuc +/- 20 %
Rated current	3.4mA ac/2.8mA dc
Power rating	135 mW</br> 155 mVA
Max. input frequency	15Hz
Auxiliary voltage	No
Status indicator	LED green

Output

Output voltage	5...48Vdc
Output current (max.)	100 mA
Voltage drop at max. load	< 1.5 V
Block-state curr. (closed circuit curr.)	< =50 µA
Switch-on delay/Switch-off delay	5ms/15ms
Short-circuit proof/Protective circuit	No/integrated freewheel diode

General data

Ambient temp., fitted w. distance	-25 °C...+60 °C
Ambient temp., fitted w/o distance	-25 °C...+60 °C
Storage temperature	-40 °C...+60 °C
Approvals	CE

Insulation coordinates (EN 50 178)

Standards	EN 50178
Rated voltage	300V
Rated impulse voltage	6.0kV
Creepage and clearance path input - output	>= 5.5 mm
Overvoltage category	III
Pollution severity	2

Rated voltage	115 Vuc +/- 20 %
Rated current	9mA ac/3.3mA dc
Power rating	0.4 W / 0.5 VA
Max. input frequency	12Hz
Auxiliary voltage	No
Status indicator	LED green

Output voltage	5...48Vdc
Output current (max.)	100 mA
Voltage drop at max. load	< 1.5 V
Block-state curr. (closed circuit curr.)	< =50 µA
Switch-on delay/Switch-off delay	9ms/25ms
Short-circuit proof/Protective circuit	No/integrated freewheel diode

Ambient temp., fitted w. distance	-25 °C...+60 °C
Ambient temp., fitted w/o distance	-25 °C...+60 °C
Storage temperature	-40 °C...+60 °C
Approvals	CE

Standards	EN 50178
Rated voltage	300V
Rated impulse voltage	6.0kV
Creepage and clearance path input - output	>= 5.5 mm
Overvoltage category	III
Pollution severity	2

Dimensions

Clamping range (rating- / min. / max.)	mm²
Length x width x height	mm

Information

Complete module Pluggable

Complete module	1.50 / 0.50 / 1.50	2.50 / 0.50 / 2.50
Pluggable	44.0 x 10.0 x 96.0	95.0 x 10.0 x 99.0

Dimensions pluggable opto-coupler incl. locking socket RS EG7

Complete module Pluggable

Complete module	1.50 / 0.50 / 1.50	2.50 / 0.50 / 2.50
Pluggable	44.0 x 10.0 x 96.0	95.0 x 10.0 x 99.0

Dimensions pluggable opto-coupler incl. locking socket RS EG7

Complete module Pluggable

Complete module	1.50 / 0.50 / 1.50	2.50 / 0.50 / 2.50
Pluggable	44.0 x 10.0 x 96.0	95.0 x 10.0 x 99.0

Dimensions pluggable opto-coupler incl. locking socket RS EG7

Ordering data

Article description

Complete module
Pluggable

Type	(Qty.=10)	Order No.
EGO EG7 48VUC K-FU		8092550000
OST EG7 48VUC		8234590000

Type	(Qty.=10)	Order No.
EGO EG7 115VUC K-FU		8092570000
OST EG7 115VUC		8234600000

Type	(Qty.=10)	Order No.
EGO EG7 230VAC K-FU		8092590000
OST EG7 230VAC		8234610000

Information

Accessories

Information

Locking socket
RS EG7 8193830000

Locking socket
RS EG7 8193830000

Locking socket
RS EG7 8193830000

Articles with coloured order number are kept permanently in stock at the central warehouse in Germany. Delivery times see page X.2

EG-SERIES

For long control wires

For long control wires

- RC-Input circuit to disable interfering signals
- Safe switching behavior in case of interfering pulses on the control side

230VAC RC

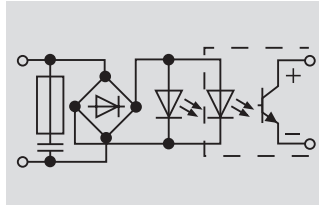

Technical data

Input

Rated voltage	230 Vac +6/-15 %
Rated current	3.8mA
Power rating	870 mVA
Max. input frequency	12Hz
Auxiliary voltage	No
Status indicator	LED green

Output

Output voltage	5...48Vdc
Output current (max.)	100 mA
Voltage drop at max. load	< 1.5 V
Block-state curr. (closed circuit curr.)	< =50 µA
Switch-on delay/Switch-off delay	5ms/18ms
Short-circuit proof/Protective circuit	No/varistor, integral freewheeling diode

General data

Ambient temp., fitted w. distance	-25 °C...+60 °C
Ambient temp., fitted w/o distance	-25 °C...+60 °C
Storage temperature	-40 °C...+60 °C
Approvals	CE

Insulation coordinates (EN 50 178)

Standards	EN 50178
Rated voltage	300V
Rated impulse voltage	6.0kV
Creepage and clearance path input - output	>= 5.5 mm
Overvoltage category	III
Pollution severity	2

Dimensions

	Complete module	Pluggable
Clamping range (rating- / min. / max.)	1.50 / 0.50 / 1.50	2.50 / 0.50 / 2.50
Length x width x height	44.0 x 10.0 x 96.0	95.0 x 10.0 x 99.0

Information

Dimensions pluggable opto-coupler
incl. locking socket RS EG7

Ordering data

Article description	Type	(Qty.=10)	Order No.
Complete module	EGO EG7 RC 230VAC		8387580000
Pluggable	OST EG7 230VAC RC		8394990000

Information

Accessories

Information	
Locking socket	RS EG7 8193830000

BT-SERIES

Installation time relays

Electronic time relays in the BT product family offer ideal solutions for industrial use.

The BT product family provides the following functions:

- Pick-up delay (BTR)
- Pulse emitter (BTTT)
- Multi-function (BTM)
- Multi-function (BTMF)
- Star delta change-over

Time ranges and power supply for the time relays

Using the central knob, the functions of the modules are selected precisely over either 4 or 8 time ranges.

The multi-voltage supply voltage range offers a wide bandwidth for industrial use (see table).

Time ranges

Display of time scale	Time range
0.1 s	0.1 to 1.2 s
1 s	1 to 12 s
0.1 min	0.1 to 1.2 min
1 min	1 to 12 min
0.1 h	0.1 to 1.2 h
1 h	1 to 12 h
10.h	10 to 120 h

Note: If the rotary knob for time adjustment is set on "0", the output will be switched without delay.

Output of the time relays

In every module, a change-over contact (250 V, 8A) switches the load. The multi-function module (BTM) activates both change-over contacts immediately, or one change-over contact immediately and the second after a delay.

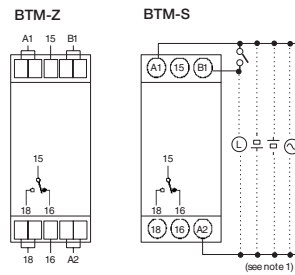

(DIN notation)

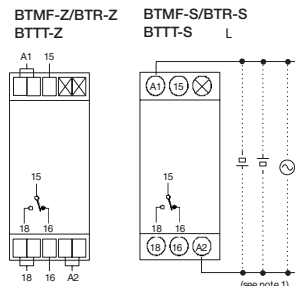

(DIN notation)



- Note:
1. Pole numbers are not necessary for DC voltage supply.
 2. The contact symbol of H3DS is marked with , as it provides several operating modes and differs from the delayed contacts of conventional time relays.

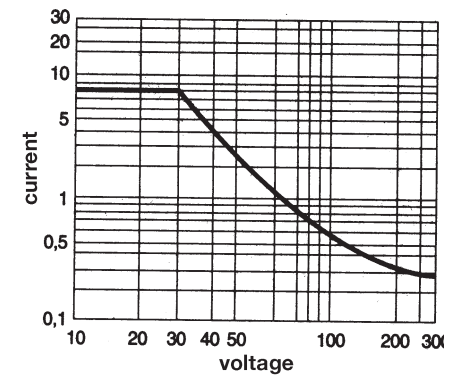
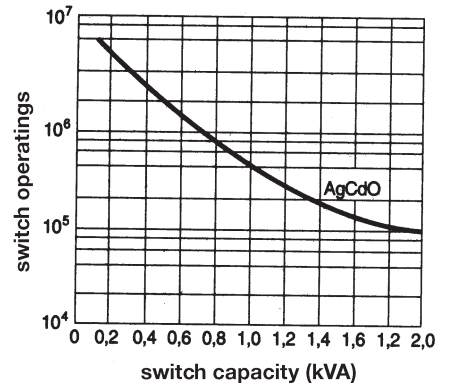

Choosing the time range

The time range is chosen by turning the rotary switch for the ON-time scale and OFF-time scale. The time scales are visible in the display left of the rotary switch in the following order: 0,1 s, 1 h, 0,1 h, 1 m, 1 s, 0,1 h, 0,1 m, 1 s.

Note: The time scales "1 s" and "0,1 h" are named twice. Both adjustments represent the same time scale.

Locking/unlocking of selectors and time setting dial

The rotary switches for the ON/OFF time adjustment and the option selector for the time scale can be locked with the locking key.

This pen-styled special tool is separately available. To lock either rotary switches or the option selector the locking key just needs to be put into the key hole on the lower right of the rotary switch/option selector is totally covered by the red cover. To unlock simply turn the key in the opposite direction.

Connection technology

The tension clamp offers the following connection capacities:

Screw connection

- 2 x 1.5 mm² with wire end ferrule
- 2 x 2.5 mm² without wire end ferrule

Tension clamp connection

- 2 x 1.5 mm² with wire end ferrule
- 2 x 2.5 mm² without wire end ferrule

Dimensions

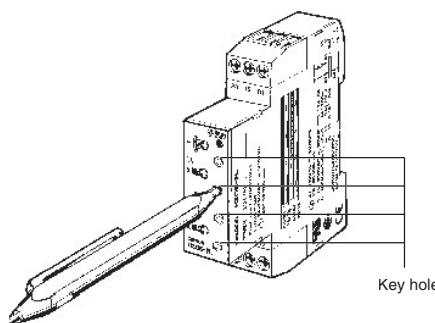
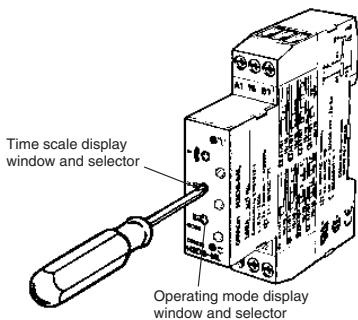
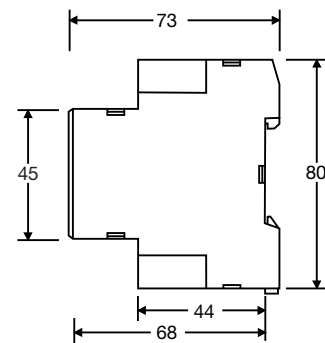

Screw connection

Tension clamp connection

BTM-S/BTMF-S

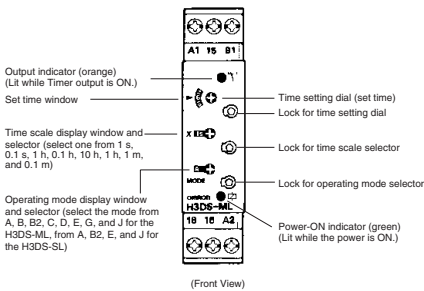

BTR-S

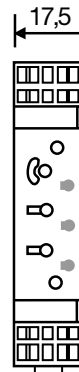
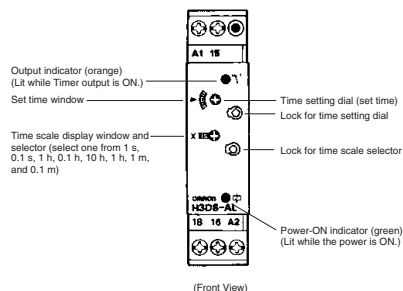

BTTT-S

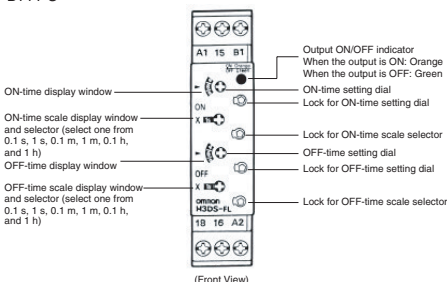

BTDS-S

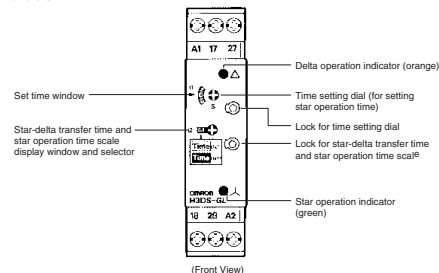

BT-SERIES

Installation time relays

- Screw or tension clamp connection
- LED status indicator Input: voltage present
Output: output active
- Approvals **UL** 508 **CE** 22.2 Nr. 14
EN 61812-1 IEC 60664-1
IEC 60947-5-1 EN 61812-1
IEC 60664-1 IEC 60947-5-1
EN 55011 EN 50082-2



Type designation:

- B** = Building
- T** = Timer
- R** = Response Delay
- TT** = Two Times
- M** = Multifunction, 8 ranges
- MF** = Multifunction, 4 ranges
- DS** = Delta, Star
- S** = Screw
- Z** = Tension

Input		Contacts hard gold plated
Rated voltage		24 ... 230 Vac, 50/60 Hz, 24 ... 48 Vdc
Voltage tolerance		85 ... 100° of rated voltage
Switch-off voltage		Max. 2.4 Vac/Vdc
Power consumption by type	Vac	21...33 VA at 230 V
	Vdc	0.6...1.3 W at 24 V
Reset time		Min. 0.1 s (BTDS: 0.5 s)
Insulation		
Insulation resistance		100 MΩ min., at 500 Vdc
Insulation test voltage		
	between input and output to enclosure	2000 Vac, 50/60 Hz, 1 min
	between non-adjacent contacts	1000 Vac, 50/60 Hz, 1 min
Protection class		IP30, terminal block IP20
Output		
Contact/contact material		1 change-over switch (BTDS 2 NOC) / AgNi 90/10
Switch output		5A at 250 Vac, resistive load (cos φ = 1)
Service life	mechanical min.	10 ⁷ switching cycles (no load, 1'800/h)
	electrical min.	10 ⁵ switching cycles (5A at 250 Vac, resistive load at 1'800/h)
Time range		0.10 s ... 120 h
Repetition accuracy		± 1 %
Other data		
Flammability class as per UL 94		V-2
Ambient temperature/storage temperature		-10...+55°C / -25 ... +65°C (without condensation)
Clamping range (nominal/min/max)	mm ²	
Length x width x height	mm	80.0 x 17.5 x 73.0

Accessories

Locking and adjusting key

BT Lock Pen 1 **865840000**

Multi-function relay with control input (BTM)

Order data

Connection technology	Type	Qty	Order no.
Screw connection	BTM-S	1	8647700000
Tension clamp	BTM-Z	1	8647710000

Functions

Function A – pick-up delay

The set time T begins to be subject to delay when the input signal (A1/B1) is applied. The output R (15/18) connects the load at the end of the set time.

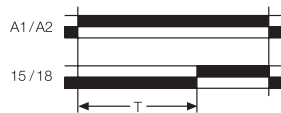

Function G – pick-up and release delayed

After applying the input signal (A1/B1), time delay T begins. At the end of this time, output R (15/18) connects the load (pick-up delayed). After the input signal (A1/B1) has been switched off again, the output switches the load off again after the set time (release delayed).

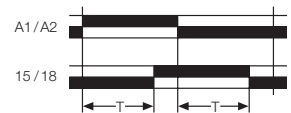

Function B – pulse emitter (starts at idle setting)

After applying the input signal (A1/B1), output R (15/18) synchronously switches the load alternately between the idle and work settings within the set time T . With this function, the cycle starts at the idle setting.



Function J – pick-up delay with pulse

After applying the input signal (A1/B1), the time delay T begins. At the end of this time, the output R (15/18) connects the load for 1 second.

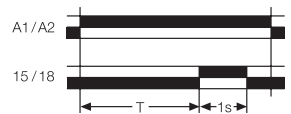

Function B2 – pulse emitter (starts at work setting)

After applying the input signal (A1/B1), output R (15/18) synchronously switches the load alternately between the idle and work settings within the set time T . With this function, the cycle starts at the work setting.

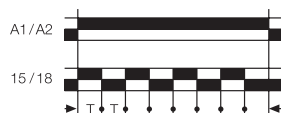

Function C – wipe function

After applying the input signal (A1/B1), output R (15/18) connects the load for the set time T . Output R switches the load off again at the end of time T .



After switching off the input signal (A1/B1), output R (15/18) connects the load again for the set time T . Output R (15/18) switches the load off again at the end of time T .

Function D – release delayed

After applying the input signal (A1/B1), output R (15/18) connects the load. The time delay T begins after the input signal (A1/B1) has been switched off. At the end of time T , output R (15/18) switches the load off again.



Function E – switch on wiping

After applying the input signal (A1/B1), output R (15/18) connects the load immediately. At the end of the set delay time T , output R (15/18) switches the load off again.



BT-SERIES

Multi-function relay without control input (BTMF)

Time relay (BTR)

Functions

Connection technology	Type	Qty	Order no.
Screw connection	BTMF-S	1	8647680000
Tension clamp	BTMF-Z	1	8647690000

Functions

Connection technology	Type	Qty	Order no.
Screw connection	BTR-S	1	8647720000
Tension clamp	BTR-Z	1	8647730000

Order data

Function A – pick-up delay

The set time T begins to be subject to delay when the power supply is applied. At the end of the set time, the output connects the load.

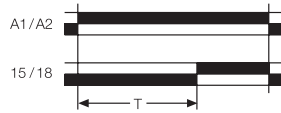

Order data

Function A – pick-up delay

The set time T begins to be subject to delay when the power supply is applied. At the end of the set time, the output R connects the load.

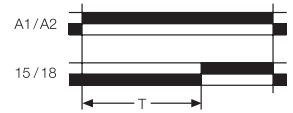

Function B2 – pulse emitter (begins with work setting)

After applying the supply voltage, output R synchronously switches the load alternately between the idle and work settings within the set time T. With this function, the cycle starts at the work setting.

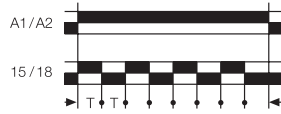

Function E – switch on wiping

After applying the supply voltage, output R connects the load immediately. After the set delay time T, output R (15/18) switches the load off again.

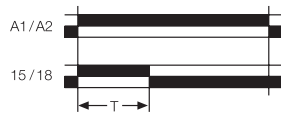

Function J – pick-up delay with pulse

After applying the power supply, the time delay T begins. At the end of this time, the output R (15/18) connects the load for 1 second.



BT-SERIES

Time relay (BTTT)

Functions

Connection technology	Type	Qty	Order no.
Screw connection	BTTT-S	1	8647740000
Tension clamp	BTTT-Z	1	8647750000

Order data

Function BTTT - pulse emitter

After applying the supply voltage, the repeat cycle begins with two independently adjusted times.

The standard setting is to begin with the idle setting.

A bridge between connections A1 and B1 allows the module to begin at the work setting.



Time relay (BTDS)

Functions

Connection technology	Type	Qty	Order no.
Screw connection	BTDS-S	1	8647660000
Tension clamp	BTDS-Z	1	8647670000

Order data

Star-delta change-over

After applying the supply voltage, output R1 (17/18) connects immediately. At the end of time T1, output R1 (17/18) switches off and time T2 starts.

At the end of time T2, output R2 (27/28) connects.

After switching off the supply voltage, output R2 (27/28) switches off.

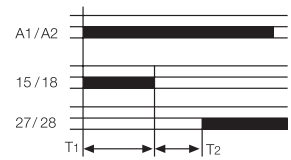

DK-SERIES

Minicoupler DKZ

- Components to lengthen short pulses for the PLC
- Provides versions with fixed switch on/switch off delay
- Low input power
- Screw connection technology
- 6 mm width
- Mounting on TS35

24VDC 50MS

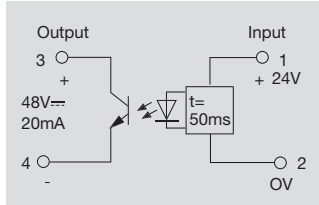
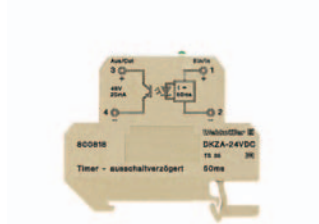

24VDC 150MS

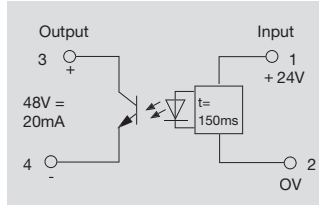
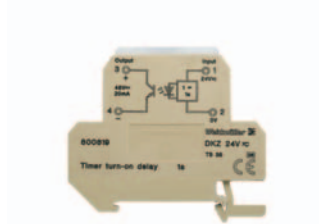

24VUC 1S

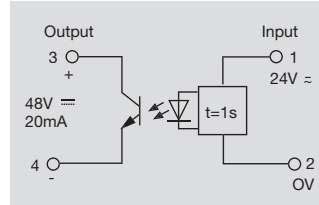
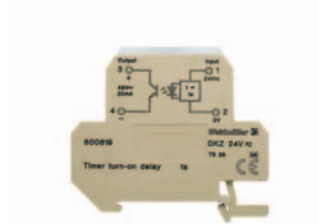

Technical data

Input

Rated voltage	24 Vdc +/- 18 %
Rated current DC	6.7mA
Rated current AC	
Power rating	160mW
Switch-on delay	
Switch-off delay	50ms
Min. impulse duration	2.0

Output

Max. switching voltage DC	48V
Switching current max.	20.0mA
Max. switching frequency at rated load	20Hz

Rated data

Ambient temp., fitted w/o distance	-25 °C...+50 °C
Storage temperature	-40 °C...+85 °C

Insulation coordinates (EN 50 178)

Rated voltage	300 V
Impulse withstand voltage	4 kV
Overvoltage category	III
Pollution severity	2
Creepage and clearance path input - output	>=4mm
Voltage strength, Input/Output	4 kV

Rated voltage	24 Vdc +/- 18 %
Rated current DC	6.7mA
Rated current AC	
Power rating	160mW
Switch-on delay	
Switch-off delay	50ms
Min. impulse duration	2.0
Max. switching voltage DC	48V
Switching current max.	20.0mA
Max. switching frequency at rated load	20Hz
Ambient temp., fitted w/o distance	-25 °C...+50 °C
Storage temperature	-40 °C...+85 °C
Rated voltage	300 V
Impulse withstand voltage	4 kV
Overvoltage category	III
Pollution severity	2
Creepage and clearance path input - output	>=4mm
Voltage strength, Input/Output	4 kV

Rated voltage	24 Vdc +/- 18 %
Rated current DC	6.7 mA
Rated current AC	
Power rating	160mW
Switch-on delay	
Switch-off delay	150ms
Min. impulse duration	2.5
Max. switching voltage DC	48V
Switching current max.	20.0mA
Max. switching frequency at rated load	20Hz
Ambient temp., fitted w/o distance	-25 °C...+50 °C
Storage temperature	-40 °C...+85 °C
Rated voltage	300 V
Impulse withstand voltage	4 kV
Overvoltage category	III
Pollution severity	2
Creepage and clearance path input - output	>=4mm
Voltage strength, Input/Output	4 kV

Rated voltage	24 Vuc +/- 10 %
Rated current DC	5.1 mA
Rated current AC	6.1 mA
Power rating	130mW / 150mVA
Switch-on delay	
Switch-off delay	1s
Min. impulse duration	max.0.7ms
Max. switching voltage DC	48V
Switching current max.	20.0mA
Max. switching frequency at rated load	0.90Hz
Ambient temp., fitted w/o distance	-25 °C...+50 °C
Storage temperature	-40 °C...+85 °C
Rated voltage	300 V
Impulse withstand voltage	4 kV
Overvoltage category	III
Pollution severity	2
Creepage and clearance path input - output	>=4mm
Voltage strength, Input/Output	4 kVeff

Dimensions

Clamping range (rating- / min. / max.)	mm²
Length x width x height	mm

Information

Screw connection

Clamping range (rating- / min. / max.)	4 / 0.50 / 4
Length x width x height	65.0 x 6.0 x 62.0

Assembly on mounting rail TS 35

Screw connection

Clamping range (rating- / min. / max.)	4 / 0.50 / 4
Length x width x height	65.0 x 6.0 x 62.0

Assembly on mounting rail TS 35

Screw connection

Clamping range (rating- / min. / max.)	4 / 0.50 / 4
Length x width x height	65.0 x 6.0 x 62.0

Assembly on mounting rail TS 35

Ordering data

Connection technology

Screw connection

Type	(Qty.=10)	Order No.
DKZA 35 24VDC 50MS		8008180000

Type	(Qty.=10)	Order No.
DKZA 35 24VDC 150MS		8022110000

Type	(Qty.=10)	Order No.
DKZ 35 24VUC 1S		8008190000

Information

Accessories

Information

End plate	AP DK4 0687560000
-----------	-------------------

End plate	AP DK4 0687560000
-----------	-------------------

End plate	AP DK4 0687560000
-----------	-------------------

DK-SERIES

Minicoupler DKZ

- Components to lengthen short pulses for the PLC
- Provides versions with fixed switch on/switch off delay
- Low input power
- Screw connection technology
- 6 mm width
- Mounting on TS35

24VDC 10-100MS

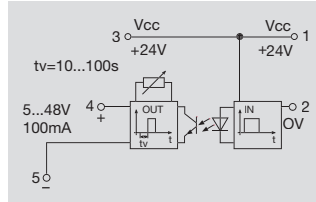
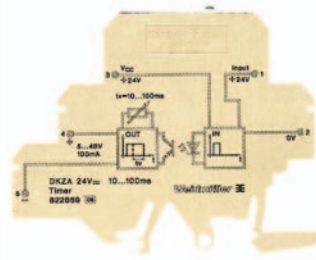

24VDC 0.1-1S

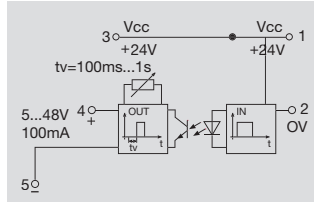

24VDC 1-100S

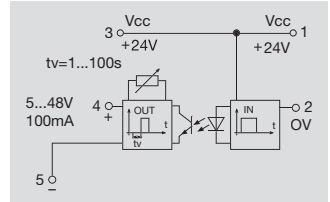

Technical data

Input

Rated voltage	24 Vdc +/- 20 %
Rated current DC	approx. 12mA
Power rating	290mW
Switch-on delay	10...100ms (adjustable)

Output

Max. switching voltage DC	48V
Switching current max.	100.0mA

Rated data

Ambient temp., fitted w/o distance	-25 °C...+50 °C
Storage temperature	-40 °C...+85 °C

Insulation coordinates (EN 50 178)

Rated voltage	300 V
Impulse withstand voltage	6 kV
Overvoltage category	IV
Pollution severity	2
Creepage and clearance path input - output	>=5.5mm
Voltage strength, Input/Output	4 kV

Rated voltage	24 Vdc +/- 20 %
Rated current DC	approx. 12mA
Power rating	290mW
Switch-on delay	10...100ms (adjustable)

Max. switching voltage DC	48V
Switching current max.	100.0mA

Ambient temp., fitted w/o distance	-25 °C...+50 °C
Storage temperature	-40 °C...+85 °C

Rated voltage	300 V
Impulse withstand voltage	6 kV
Overvoltage category	IV
Pollution severity	2
Creepage and clearance path input - output	>=5.5mm
Voltage strength, Input/Output	4 kV

Rated voltage	24 Vdc +/- 20 %
Rated current DC	approx. 12mA
Power rating	290mW
Switch-on delay	100ms...1s (adjustable)

Max. switching voltage DC	48V
Switching current max.	100.0mA

Ambient temp., fitted w/o distance	-25 °C...+50 °C
Storage temperature	-40 °C...+85 °C

Rated voltage	300 V
Impulse withstand voltage	6 kV
Overvoltage category	IV
Pollution severity	2
Creepage and clearance path input - output	>=5.5mm
Voltage strength, Input/Output	4 kV

Rated voltage	24 Vdc +/- 20 %
Rated current DC	approx. 12mA
Power rating	290 mW
Switch-on delay	1...100s (adjustable)

Max. switching voltage DC	48V
Switching current max.	100.0mA

Ambient temp., fitted w/o distance	-25 °C...+50 °C
Storage temperature	-40 °C...+85 °C

Rated voltage	300 V
Impulse withstand voltage	6 kV
Overvoltage category	IV
Pollution severity	2
Creepage and clearance path input - output	>=5.5mm
Voltage strength, Input/Output	4 kV

Dimensions

Clamping range (rating- / min. / max.)	mm ²
Length x width x height	mm

Information

Screw connection

4 / 0.50 / 4
77.0 x 6.0 x 62.0

Assembly on mounting rail
TS32/35

Screw connection

4 / 0.50 / 4
77.0 x 6.0 x 62.0

Assembly on mounting rail
TS32/35

Screw connection

4 / 0.50 / 4
77.0 x 6.0 x 62.0

Assembly on mounting rail
TS32/35

Ordering data

Connection technology

Screw connection

Type	(Qty.=10)	Order No.
DKZ DK5 24VDC 10-100MS		8228680000

Type	(Qty.=10)	Order No.
DKZ DK5 24VDC 0.1-1S		8243780000

Type	(Qty.=10)	Order No.
DKZ DK5 24VDC 1-100S		8019650000

Information

Accessories

Information

End plate	
AP DK5 8268870000	

End plate	
AP DK5 8268870000	

End plate	
AP DK5 8268870000	

Articles with coloured order number are kept permanently in stock at the central warehouse in Germany.
Delivery times see page X.2

DK-SERIES

Minicoupler DKZ

- Components to lengthen short pulses for the PLC
- Provides versions with fixed switch on/switch off delay
- Low input power
- Screw connection technology
- 6 mm width
- Mounting on TS35

24VDC 10-100MS

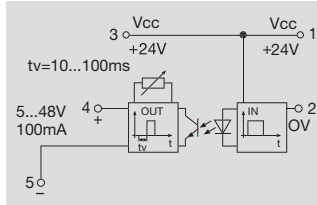
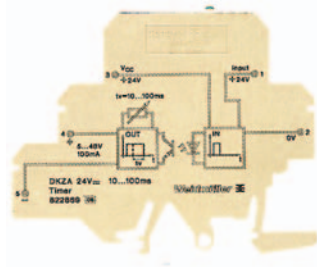

24VDC 0,1-1S

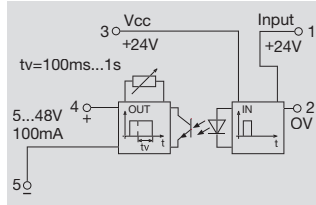
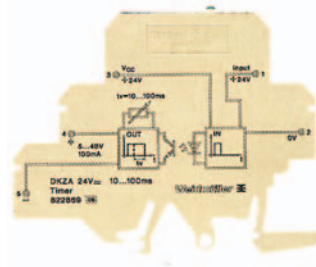

24VDC 1-100S

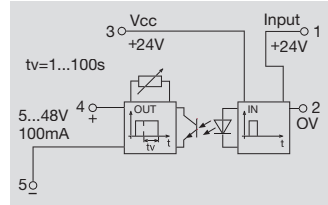

Technical data

Input

Rated voltage
Rated current DC
Power rating
Switch-off delay

24 Vdc +/- 20 %
approx. 11mA

24 Vdc +/- 20 %
approx. 11mA

24 Vdc +/- 20 %
approx. 11mA

Output

Max. switching voltage DC
Switching current max.

48V
100.0mA

48V
100.0mA

48V
100.0mA

Rated data

Ambient temp., fitted w/o distance
Storage temperature

-25 °C...+50 °C
-40 °C...+85 °C

-25 °C...+50 °C
-40 °C...+85 °C

-25 °C...+50 °C
-40 °C...+85 °C

Insulation coordinates (EN 50 178)

Rated voltage
Impulse withstand voltage
Overvoltage category
Pollution severity
Creepage and clearance path input - output
Voltage strength, Input/Output

300 V
6 kV
IV
2
>=5.5mm

300 V
6 kV
IV
2
>=5.5mm
4 kV

300 V
6 kV
IV
2
>=5.5mm
4 kV

Dimensions

Clamping range (rating- / min. / max.) mm²
Length x width x height mm

Screw connection

4 / 0.50 / 4
77.0 x 6.0 x 62.0

Screw connection

4 / 0.50 / 4
77.0 x 6.0 x 62.0

Screw connection

4 / 0.50 / 4
77.0 x 6.0 x 62.0

Information

Assembly on mounting rail
TS32/35

Assembly on mounting rail
TS32/35

Assembly on mounting rail
TS32/35

Ordering data

Connection technology

Screw connection

Type	(Qty.=10)	Order No.
DKZA DK5 24VDC 10-100MS		8228690000

Type	(Qty.=10)	Order No.
DKZA DK5 24VDC 0.1-1S		8243770000

Type	(Qty.=10)	Order No.
DKZA DK5 24VDC 1-100S		8019630000

Information

Accessories

Information

End plate
AP DK5 8268870000

End plate
AP DK5 8268870000

MCZ-SERIES

Miniconditioner MCZ TO

- Components to lengthen short pulses for the PLC
- Switch-off delay fixed adjusted
- Low input power
- Tension clamp connection technology
- Pluggable cross-connection
- 6 mm width
- Mounting on TS35

24VDC 50MS

24VDC 150MS

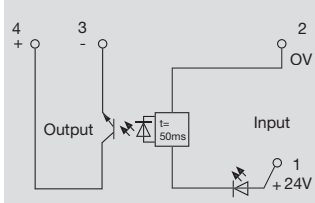
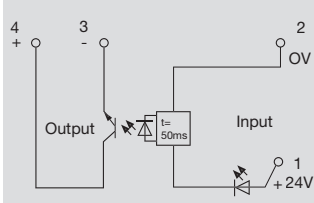
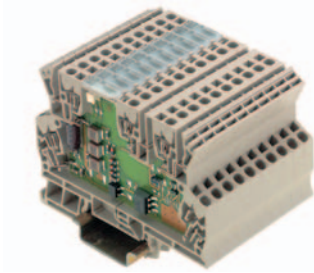

Technical data

Input

Rated voltage	24 Vdc +/- 10 %
Rated current DC	6.7mA +/-10%
Power rating	160mW
Switch-off delay	50ms
Min. impulse duration	2.0ms

Output

Max. switching voltage DC	48V
Switching current max.	20.0mA
Max. switching frequency at rated load	20Hz

Rated data

Ambient temp., fitted w. distance	-25 °C...+50 °C
Storage temperature	-40 °C...+85 °C

Insulation coordinates (EN 50 178)

Rated voltage	300 V
Impulse withstand voltage	6 kV
Overvoltage category	III
Pollution severity	2
Creepage and clearance path input - output	>=5.5mm
Voltage strength, Input/Output	4 kV

Rated voltage	24 Vdc +/- 10 %
Rated current DC	6.7mA +/-10%
Power rating	160mW
Switch-off delay	50ms
Min. impulse duration	2.0ms

Max. switching voltage DC	48V
Switching current max.	20.0mA
Max. switching frequency at rated load	20Hz

Ambient temp., fitted w. distance	-25 °C...+50 °C
Storage temperature	-40 °C...+85 °C

Rated voltage	300 V
Impulse withstand voltage	6 kV
Overvoltage category	III
Pollution severity	2
Creepage and clearance path input - output	>=5.5mm
Voltage strength, Input/Output	4 kV

Rated voltage	24 Vdc +/- 10 %
Rated current DC	6.7mA +/-10%
Power rating	160mW
Switch-off delay	150ms
Min. impulse duration	2.5ms

Max. switching voltage DC	48V
Switching current max.	20.0mA
Max. switching frequency at rated load	20Hz

Ambient temp., fitted w. distance	-25 °C...+50 °C
Storage temperature	-40 °C...+85 °C

Rated voltage	300 V
Impulse withstand voltage	6 kV
Overvoltage category	III
Pollution severity	2
Creepage and clearance path input - output	>=5.5mm
Voltage strength, Input/Output	4 kV

Dimensions

Clamping range (rating- / min. / max.)	mm ²
Length x width x height	mm

Information

Tension clamp c.

Clamping range (rating- / min. / max.)	1.50 / 0.50 / 2.50
Length x width x height	91.0 x 6.0 x 63.2

CE, UL, CSA
Assembly on TS35

Tension clamp c.

Clamping range (rating- / min. / max.)	1.50 / 0.50 / 2.50
Length x width x height	91.0 x 6.0 x 63.2

CE, UL, CSA
Assembly on TS35

Ordering data

Connection technology

Tension clamp c.

Type	(Qty.=10)	Order No.
MCZ TO 24VDC/50MS		8324590000

Type	(Qty.=10)	Order No.
MCZ TO 24VDC/150MS		8286410000

Information

Accessories

Information

Endplate	AP MCZ 8389030000
----------	-------------------

End plate	AP MCZ 8389030000
-----------	-------------------

Articles with coloured order number are kept permanently in stock at the central warehouse in Germany.
Delivery times see page X.2

Overview

Switch and button modules

The dimensions of the switch and button modules are adapted to the electronic components in the integral housing.

The modules are equipped with the universal clip-on foot structure to slot onto mounting rails TS 32, TS 35 x 7.5 and TS 35 x 15 as per EN 50035 and EN 50022.

Buttons and switches simplify the commissioning, maintenance, monitoring and repair of the systems. The contacts are rated for inductive or resistive load.

When switching inductive loads, a contact protection circuit is to be provided, such as Weidmüller terminals with diodes or RC combination.

Fuse modules

Unlike fuse terminals with a failure indicator, here an LED indicates that the fuse is functional. The circuit carries no closed-circuit current when the fuse is defective.

Example of use:

Fuse for a solenoid valve

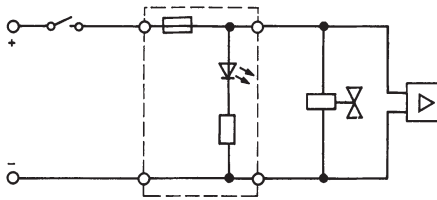

If the fuse is defective, no information is sent to the electronic component.

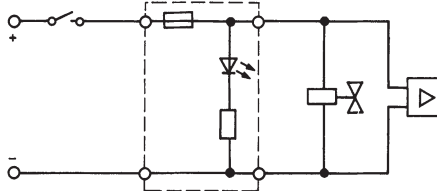

If the fuse is defective, the electronic component receives – via the current of the LED display – incorrect information about the switching state of the solenoid valve.

Rectifier circuit

EGD rectifier modules are accommodated in EG2 housing which slot onto the mounting rail.

The bridge circuit consists of 4 individual diodes which allow for an extended input voltage range of 5 V to 240 Vac.

The DC output voltage is 90% of the AC input voltage; a load capacitor is not used. Varistors in both the input and output systems protect the industry-grade rectifier circuits from dangerous overvoltages.

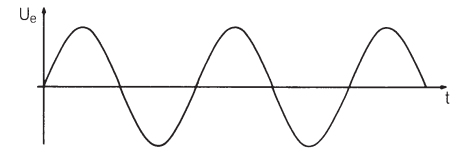

Input voltage

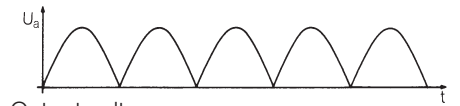

Output voltage

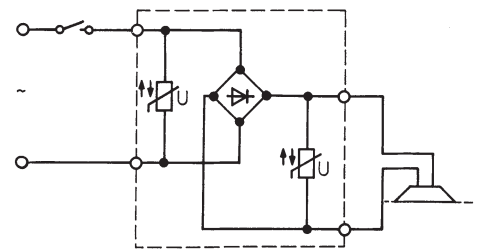

Diode array

The modules group up to 40 diodes together on a PCB and route the module connections to screw terminals or spade connectors.

Clip-in bases with diode arrays can be slotted onto mounting rails TS 32, TS 35 x 7.5 and TS 35 x 15 as per EN 50035 and EN 50022.

Diode arrays can be used for reverse voltage protection, for circuit deletion or as linking modules. They are ideal for setting up fault alarm units with up to 40 inputs. 1N4007 diodes are used. The lock voltage is 1300 V, feed-through current is 1 A with a surge current of up to 10 A permissible.

Assembly modules

Axial components such as resistors, diodes and capacitors can be soldered into the insertion modules. Five components can be soldered to solder lugs in one RSX, and 8 in the other.

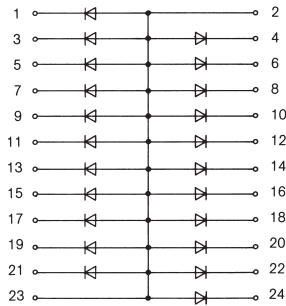

Alarm and command modules

EGT 1

Switch and button module



EGS

Fuse module with display

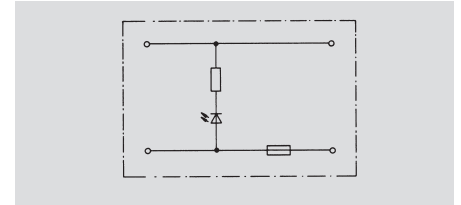

Technical data

Nominal data
Input voltage
Rated current

Max. 250 V~	EGT 0	EGT 1 to EGT 6
Resistive load	3 A/250 V~	6 A/250 V~
Inductive load	5 A/30 V~	4 A/250 V~

230 V~ or 24 V~ or 42 V~
Max. 6.3 A
5 x 20 mm fuse

Storage temperature	-40 °C...+100 °C
Ambient temperature	-25 °C...+85 °C
- fitted without spacing on TS	-25 °C...+85 °C
- fitted with 20 mm spacing on TS	-25 °C...+85 °C
Insulation coordination as per EN 50 178	
Overvoltage category	1
Pollution severity	2

Storage temperature	-40 °C...+100 °C
Ambient temperature	-25 °C...+85 °C
- fitted without spacing on TS	-25 °C...+85 °C
- fitted with 20 mm spacing on TS	-25 °C...+85 °C
Insulation coordination as per EN 50 178	
Overvoltage category	1
Pollution severity	2

Storage temperature	-40 °C...+100 °C
Ambient temperature	-25 °C...+85 °C
- fitted without spacing on TS	-25 °C...+85 °C
- fitted with 20 mm spacing on TS	-25 °C...+85 °C
Insulation coordination as per EN 50 178	
Overvoltage category	1
Pollution severity	2

K

Order data

Type	Switching function	Qty	Order no.
EGT 0	1 NOC	10	8002290000
	1 NOC		
EGT 1	Circuit breaker	10	0126360000
EGT 2	Change-over contact, switching	10	0104060000
EGT 3	Change-over contact, off position in the middle, switching to both sides	10	0104160000
EGT 4	Change-over contact, off position in the middle, button to one side, switching to one side	10	0104360000
EGT 5	Change-over contact, off position in the middle, button to both sides	10	0104260000
EGT 6	Change-over contact, button	10	0114660000

Type	Qty	Order no.
EGS 230 V~	10	1115860000
EGS 24 V~	10	0193860000
EGS 42 V~	10	8029370000

Type	Qty	Order no.
EGS 230 V~	10	1115860000
EGS 24 V~	10	0193860000
EGS 42 V~	10	8029370000

Rectifier modules

EGD 1

Rectifier circuit

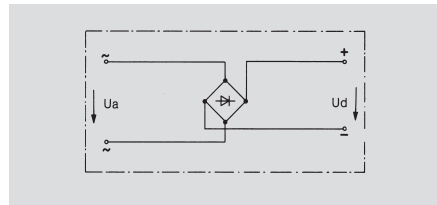
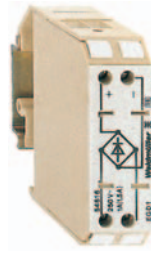

EGD 2

Rectifier circuit with varistor protection circuit

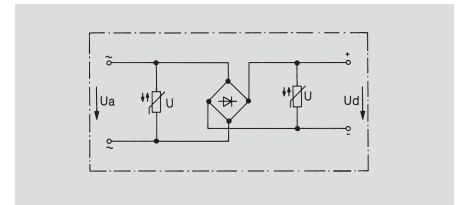
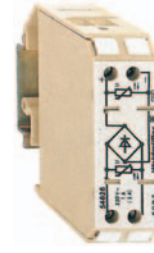

Technical data

Nominal data
Input voltage
Rated current

Derating curve
 a = fitted without spacing on mounting rail
 b = fitted at 20 mm spacing on mounting rail



Max. downstream load capacitor
Current load max.
Surge current limit value
Conducting-state voltage
Output voltage
Storage temperature
Ambient temperature
- fitted without spacing on mounting rail
- fitted at 20 mm spacing on mounting rail
Insulation coordination as per EN 50 178
Overvoltage category
Pollution severity

5 V~...240 V~, 50...60 Hz
1 A

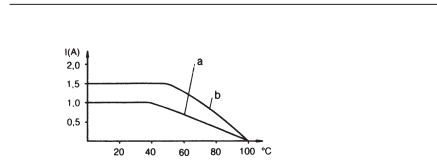

200 µF
1.5A (see derating curve)
40 A (10 ms)
≤ 2 V
$U_d = 0,9 \times U_a$
-45 °C...+100 °C
-30 °C...+40 °C
-30 °C...+70 °C
II
2

5 V~...240 V~, 50...60 Hz
1 A

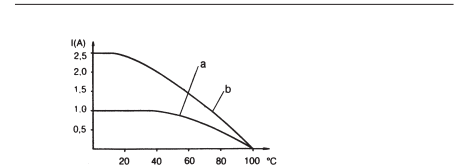

500 µF
2.5 A (see derating curve)
10 A (10 ms)
≤ 2.2 V
$U_d = 0,9 \times U_a$
-45 °C...+100 °C
-30 °C...+40 °C
-30 °C...+70 °C
II
2

Order data

--

Type	Qty.	Order no.
EGD 1	10	0546160000

Type	Qty.	Order no.
EGD 2	10	0546260000

Diode array

with clip-on foot for TS 32, TS35x7.5 and TS35x15

RSD A

with joint anode or cathode

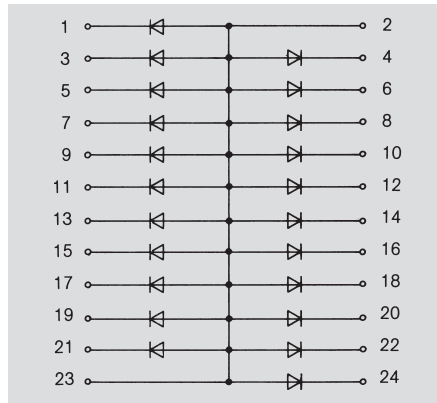
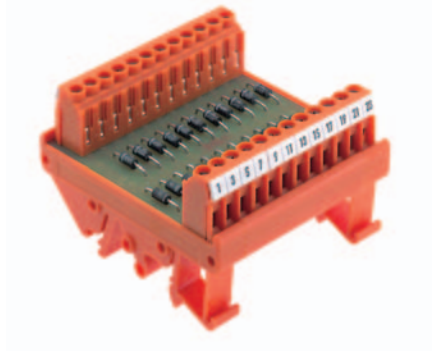

RSD K

RSD

with open diode connections

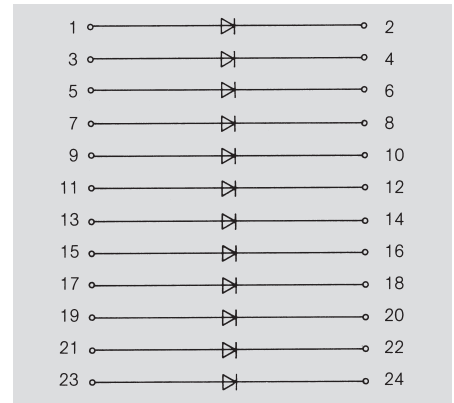

Technical data

Connection data	
Screw connection, solid	0.5...4 mm ²
Screw connection, flexible	0.5...2.5 mm ²
Conductor cross-sectional area	AWG 26...14
Spade connection	0.8 x 2.8 or 0.8 x 6.3 mm
Nominal data	
Operating voltage max.	250 V
Diode reverse voltage	1000 V
Diode current	1 A
Insulation coordination as per EN 50 178	
Overvoltage category	III
Pollution severity	2

Dimensions	RSD A	RSD A	RSD 12	RSD 10	RSD 20	RSD 40
	Base width	65	65	65	60	120
Stripping length	7	7	7	7	7	7
Remarks						

Order data

	Type	Qty.	Order no.
Screw connection	RSD A	22 diodes 1N4007	1 0180961001
	RSD K	22 diodes 1N4007	1 0181061001
Spade connection	RSD A-F	22 diodes 1N4007	1 0181160000
	RSD K-F	22 diodes 1N4007	1 0181260000
Screw connection	RSD	12 diodes 1N4007	1 0181461001
	RSD 10	10 diodes 1N4007	1 8022901001
Spade connection	RSD-F	12 diodes 1N4007	1 0181360000
	RSD 20	20 diodes 1N4007	1 8022911001
	RSD 40	40 diodes 1N4007	1 8022921001
Mounting rails and end brackets: see chapter F			

Rectifier modules

RSX

RSX-ADP

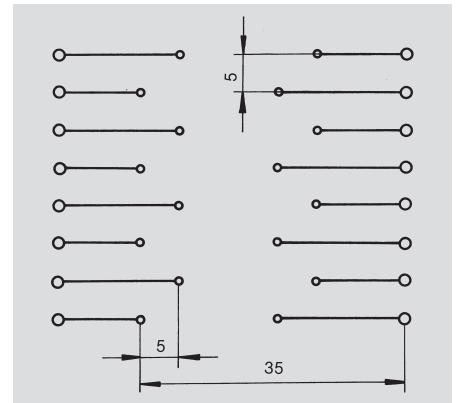
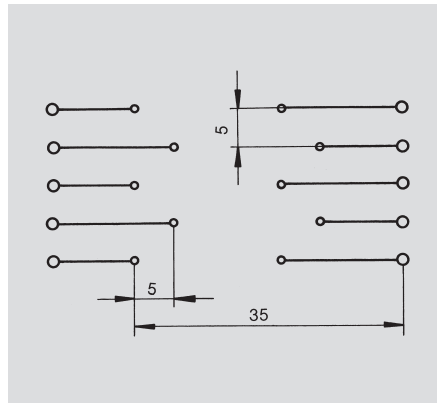
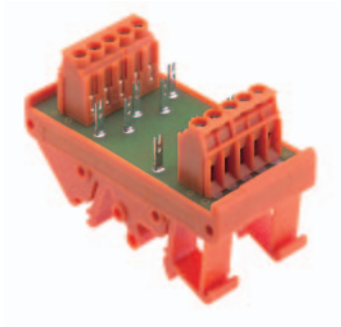

Technical data

Connection data			
Screw connection, solid		0.5...4 mm ²	0.5...4 mm ²
Screw connection, flexible		0.5...2.5 mm ²	0.5...2.5 mm ²
Conductor cross-sectional area		AWG 26...14	AWG 26...14
Spade connection		0.8 x 2.8 or 0.8 x 6.3 mm	0.8 x 2.8 or 0.8 x 6.3 mm
Nominal data			
Operating voltage max.		250 V/5 A	250 V/5 A
Diode reverse voltage			
Diode current			
Insulation coordination as per EN 50 178			
Overvoltage category		II	II
Pollution severity		2	2
Dimensions			
Base width	mm	35	50
Stripping length	mm	7	7
Remarks			

Order data

	Type	Qty.	Order no.	Type	Qty.	Order no.
Screw connection	RSX	1	0329761001	RSX-ADP	1	8022051001
Spade connection	RSX-F	1	0329860000			
	for soldering in 5 components solder lug 6 mm high solder lug spacing: approx. 20 mm			for soldering in 8 components solder lug 6 mm high solder lug spacing: approx. 20 mm		
	Mounting rails and end brackets: see chapter F			Mounting rails and end brackets: see chapter F		

Articles with coloured order number are kept permanently in stock at the central warehouse in Germany. Delivery times see page X.2

Logic modules

Inputs and outputs

Amplified DKV

DKV 5Vdc

DKV 24 Vdc

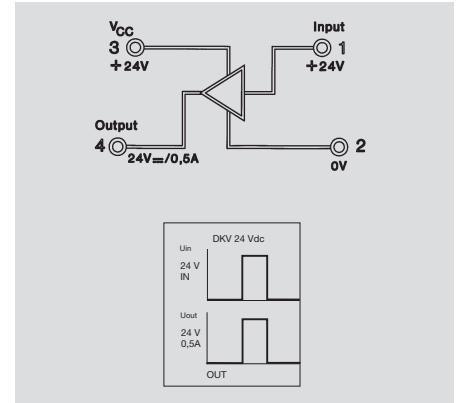
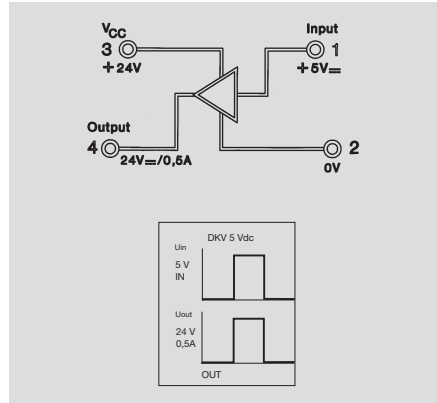
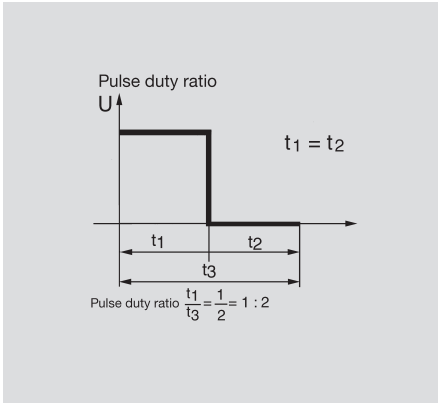
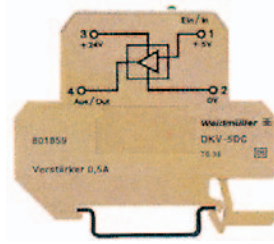

Technical data

Input voltage	
Switching threshold	
Input current	
Power loss, max.	
Output voltage	
Output current, max.	
Output current, min.	
Switching frequency, max.; duty factor 1:2	
Voltage drop at max. load	
Block-state current	
Insulation coordination as per EN 50178	
Operating temperature	without spacing
	with spacing
Storage temperature	
Conductor	
Conductor cross-sectional area	
Width	

5 Vdc $\pm 10\%$	
off: $\leq 1.5\text{ V}$ on: $\geq 4.5\text{ V}$	
approx. 3 V	
100 μA	
500 μW	
24 Vdc	
500 mA	
50 μA	
3 kHz	
$\leq 450\text{ mV}$	
$\leq 20\text{ }\mu\text{A}$	
no galvanic isolation between input and output	
-25 °C...+40 °C	
-25 °C...+50 °C	
-40 °C...+85 °C	
AWG 22...12	
0.5...4 mm ²	
6 mm	

24 Vdc $\pm 10\%$	
off: $\leq 6\text{ V}$ on: $\geq 20.4\text{ V}$	
approx. 13 V	
5 mA	
550 mW	
24 Vdc	
500 mA	
50 μA	
3 kHz	
$\leq 900\text{ mV}$	
$\geq 50\text{ }\mu\text{A}$	
no galvanic isolation between input and output	
-25 °C...+40 °C	
-25 °C...+50 °C	
-25 °C...+85 °C	
AWG 22...12	
0.5...4 mm ²	
6 mm	

Order data

for TS 35

Type	Order no.
DKV 5 Vdc	8018590000
input at bottom	

Type	Order no.
DKV 24 Vdc	8015790000
input at bottom	

Accessories

End plate

Type	Order no.
AP DKT4	0687560000

Type	Order no.
AP DKT4	0687560000

Logic modules

Inputs and outputs

Amplified DKV

DKLI 24Vdc

DKPI 24 Vdc

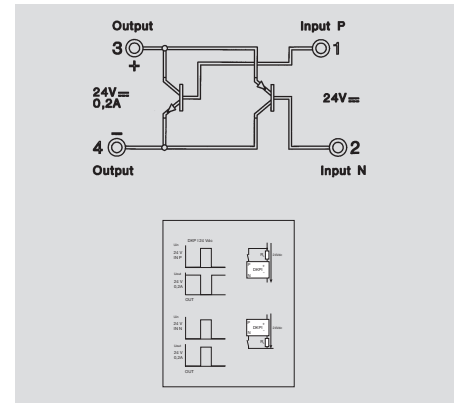
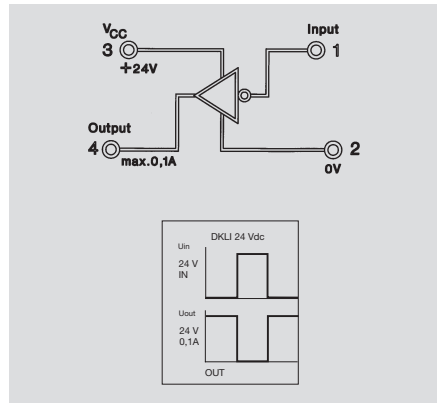
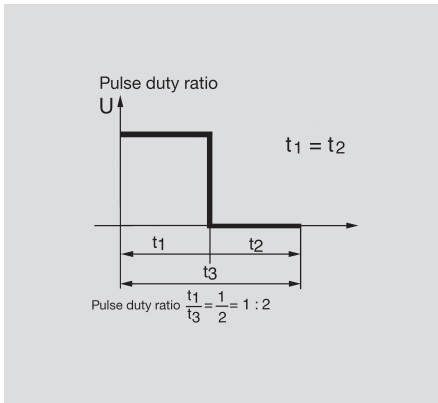
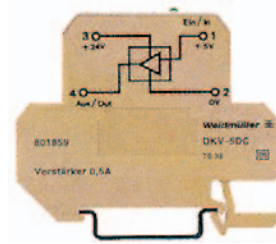

Technical data

Input voltage	
Switching threshold	
Input current	
Power loss, max.	
Output voltage	
Output current, max.	
Output current, min.	
Switching frequency, max.; duty factor 1:2	
Voltage drop at max. load	
Block-state current	
Insulation coordination as per EN 50178	
Operating temperature	without spacing
	with spacing
Storage temperature	
Conductor	
Conductor cross-sectional area	
Width	

24 Vdc ± 10 %	
off: ≥ 20.4 V on: ≤ 4 V	
approx. 8 V	
7,5 mA	
230 mW	
24 Vdc	locked
100 mA	0 mA
50 µA	
3 kHz	
100 mV	
≤ 50 µA	
no isolation between input and output	
-25 °C...+40 °C	
-25 °C...+50 °C	
-40 °C...+85 °C	
AWG 22...12	
0.5...4 mm ²	
6 mm	

P: 24 Vdc ±10 %	
N: -2.4...+2.4 Vdc	
P: approx. 18 V / N: approx. 8 V	
approx. 8 mA	
approx. 500 mW	
24 Vdc	
200 mA	
50 µA	
3 kHz	
≤ 1,5 V	
≤ 50 µA	
no isolation between input and output	
-25 °C...+40 °C	
-25 °C...+50 °C	
-25 °C...+85 °C	
AWG 22...12	
0.5...4 mm ²	
6 mm	

Order data

for TS 35	

Type	Order no.
DKLI 24 Vdc	8010950000
input at bottom	

Type	Order no.
DKPI 24 Vdc	8019530000
input at bottom	

Accessories

End plate	

Type	Order no.
AP DKT4	0687560000

Type	Order no.
AP DKT4	0687560000

Articles with coloured order number are kept permanently in stock at the central warehouse in Germany. Delivery times see page X.2

