

Data Sheet

Rev. 1.11 / July 2010

ZSC31050

Advanced Differential Sensor Signal Conditioner



ZSC31050

Advanced Differential Sensor Signal Conditioner

ZMDI[®]
The Analog Mixed Signal Company



Brief Description

ZSC31050 is a CMOS integrated circuit for highly accurate amplification and sensor-specific correction of bridge sensor and temperature sensor signals. The device provides digital compensation of sensor offset, sensitivity, temperature drift and non-linearity by a 16-bit RISC micro-controller running a polynomial correction algorithm.

ZSC31050 accommodates virtually any bridge sensor type (e.g. piezo-resistive, ceramic-thickfilm or steel membrane based). In addition, the IC can interface to a separate temperature sensor. The bi-directional digital interfaces (I²C, SPI, and ZACwire™) can be used for a simple PC-controlled one-shot calibration procedure to program a set of calibration coefficients into an on-chip EEPROM. Thus a specific sensor and a ZSC31050 can be mated digitally: fast, precise and without the cost overhead associated with trimming by external devices or laser. The ZACwire™ interface enables an end-of-line calibration of the sensor module.

ZSC31050 has been designed for industrial, medical and consumer applications and is specifically engineered for most pressure sensors. It can also be used with force, torque, acceleration, angle, position and revolution sensors.

Benefits

- No external trimming components required
- PC-controlled configuration and calibration via digital bus interface – simple, low cost
- High accuracy ($\pm 0.1\%$ FSO @ -25 to 85°C; $\pm 0.25\%$ FSO @ -40 to 125°C) *

Available Support

- Application kit available (including calibration board, SSOP16 samples, software, technical documentation)
- Support for industrial mass calibration available
- Quick circuit customization possible for large production volumes

Features

- Digital compensation of sensor offset, sensitivity, temperature drift and non-linearity
- Accommodates nearly all bridge sensor types (signal spans from 1 up to 275mV/V processable)
- Digital one-shot calibration: quick and precise
- Selectable compensation temperature T1 source: bridge, thermistor, internal or external diode
- Output options: voltage (0 to 5V), current (4 to 20mA), PWM, I²C, SPI, ZACwire™ (one-wire interface), PWM, alarm
- Adjustable output resolution (up to 15 bits) versus sampling rate (up to 3.9kHz)
- Current consumption: typ. 2.5mA
- Selectable bridge excitation: ratiometric voltage, constant voltage or constant current
- Input channel for separate temperature sensor
- Sensor connection and common mode check (sensor aging detection)

Physical Characteristics

- Operation temperature -40 to +125°C (-40 to +150°C derated, depending on product version)
- Supply voltage 2.7 to 5.5 V with external JFET 5 to 40V
- Available in SSOP16 package or as die

ZSC31050 Overview

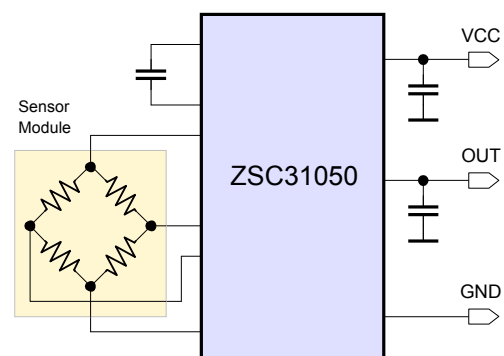

* digital output signal

ZSC31050

Advanced Differential Sensor Signal Conditioner



The Analog Mixed Signal Company



ZSC31050 Block Diagram

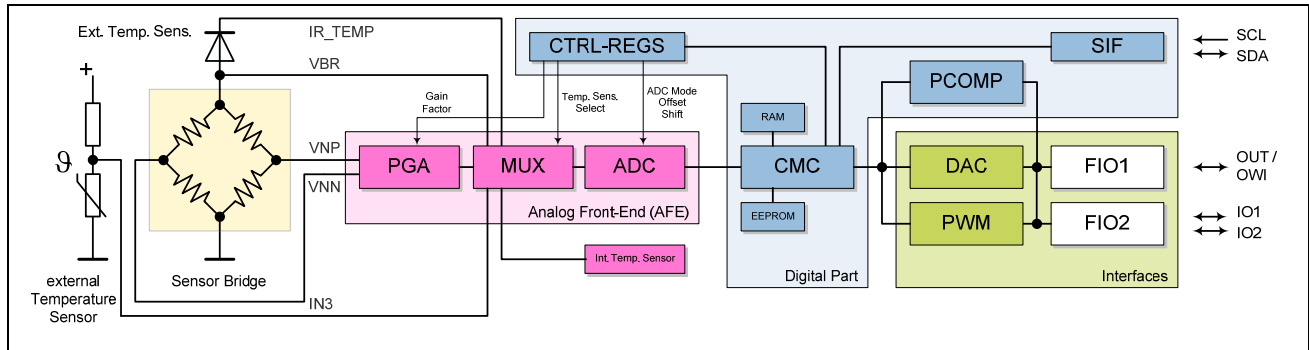

Ordering Information

Example: **ZSC31050 D I G1 - T**

ZMDI Product Sales Name

Design Revision

The revision level is indicated alphabetically beginning with A for first revision level

Target Application Area/

Normal Operating Temperature Range

- C = Consumer (0°C to +70°C)
- I = Industrial (-25°C to 85°C)
- A = Automotive (-40°C to +125°C)
- E = Extended Automotive (-40°C to +150°C)

Delivery Form *

- T = Delivery in tube
- R = Delivery in tape on reel

Die/Package Options

- B = Tested dice on unsawn wafer
- C = Tested dice on frame
- D = Tested dice in waffle pack
- G1 = Finished parts, RoHS-compliant, in plastic package

* Only for finished parts in plastic package

Not all possible combinations are available. Please ask ZMDI sales

Product Sales Code	Description	Package
ZSC31050KIT Evaluation Kit V3.0	Modular evaluation and development boards for ZSC31050	KIT boards, IC samples, USB cable, DVD with software and documentation
ZSC31050 Mass Calibration System V1.1	Modular Mass Calibration System (MSC) for ZSC31050	MCS boards, cable, connectors, DVD with software and documentation

Sales and Further Information

www.zmdi.com

sales@zmdi.com

Zentrum Mikroelektronik Dresden AG
Grenzstrasse 28
01109 Dresden
Germany

Phone +49 (0)351.8822.7.772
Fax +49(0)351.8822.87.772

ZMD America, Inc.
8413 Excelsior Drive
Suite 200
Madison, WI 53717
USA

Phone +01 (608) 829-1987
Fax +01 (631) 549-2882

Zentrum Mikroelektronik Dresden AG, Japan Office
2nd Floor, Shinbashi Tokyu Bldg.
4-21-3, Shinbashi, Minato-ku
Tokyo, 105-0004
Japan

Phone +81.3.6895.7410
Fax +81.3.6895.7301

ZMD Far East, Ltd.
3F, No. 51, Sec. 2,
Keelung Road
11052 Taipei
Taiwan

Phone +886.2.2377.8189
Fax +886.2.2377.8199

DISCLAIMER: This information applies to a product under development. Its characteristics and specifications are subject to change without notice. Zentrum Mikroelektronik Dresden AG (ZMD AG) assumes no obligation regarding future manufacture unless otherwise agreed to in writing. The information furnished hereby is believed to be true and accurate. However, under no circumstances shall ZMD AG be liable to any customer, licensee, or any other third party for any special, indirect, incidental, or consequential damages of any kind or nature whatsoever arising out of or in any way related to the furnishing, performance, or use of this technical data. ZMD AG hereby expressly disclaims any liability of ZMD AG to any customer, licensee or any other third party, and any such customer, licensee and any other third party hereby waives any liability of ZMD AG for any damages in connection with or arising out of the furnishing, performance or use of this technical data, whether based on contract, warranty, tort (including negligence), strict liability, or otherwise.

© 2010 Zentrum Mikroelektronik Dresden AG — Rev. 1.11

All rights reserved. The material contained herein may not be reproduced, adapted, merged, translated, stored, or used without the prior written consent of the copyright owner. The information furnished in this publication is subject to changes without notice.



Contents

1	Electrical Characteristics	6
1.1.	Absolute Maximum Ratings	6
1.2.	Operating Conditions (Voltages related to VSS)	6
1.3.	Build In Characteristics	7
1.3.1.	Cycle Rate versus A/D-Resolution	8
1.3.2.	PWM Frequency	8
1.4.	Electrical Parameters (Voltages related to VSS)	9
1.4.1.	Supply / Regulation	9
1.4.2.	Analog Front End	9
1.4.3.	DAC & Analog Output (Pin OUT)	9
1.4.4.	PWM Output (Pin OUT, IO1)	9
1.4.5.	Temperature Sensors (Pin IR_TEMP)	9
1.4.6.	Digital Outputs (IO1, IO2, OUT in digital mode)	9
1.4.7.	System Response	10
1.5.	Interface Characteristics	11
1.5.1.	Multiport Serial Interfaces (I ² C, SPI)	11
1.5.2.	One Wire Serial Interface (ZACwire™)	11
2	Circuit Description	12
2.1.	Signal Flow	12
2.2.	Application Modes	13
2.3.	Analog Front End (AFE)	14
2.3.1.	Programmable Gain Amplifier (PGA)	14
2.3.2.	Extended Zero Point Compensation (XZC)	14
2.3.3.	Measurement Cycle realized by Multiplexer	15
2.3.4.	Analog-to-Digital Converter	16
2.4.	System Control	17
2.5.	Output Stage	18
2.5.1.	Analog Output	19
2.5.2.	Comparator Module (ALARM Output)	19
2.5.3.	Serial Digital Interface	19
2.6.	Voltage Regulator	19
2.7.	Watchdog and Error Detection	20
3	Application Circuit Examples	21
4	ESD/Latch-Up-Protection	23
5	Pin Configuration and Package	23
6	Reliability	24
7	Customization	24
8	Ordering Information	25
9	Related Documents	25
10	Glossary	26
11	Document Revision History	27



List of Figures

Figure 2.1	Block Diagram of the ZSC31050	12
Figure 3.1	Example 1	21
Figure 3.2	Example 2	21
Figure 3.3	Example 3	21
Figure 3.4	Example 4	21
Figure 3.5	Example 5	22
Figure 4.1.	Pin Configuration	24

List of Tables

Table 1.1	Absolute Maximum Ratings	6
Table 1.2	Operating Conditions	6
Table 1.3	Build In Characteristics	7
Table 1.4	Cycle Rate versus A/D-Resolution	8
Table 1.5	PWM Frequency	8
Table 1.6	Electrical Parameters	9
Table 1.7.	Interface Characteristics	11
Table 2.1	Adjustable gains, resulting sensor signal spans, and common mode ranges.....	14
Table 2.2	Extended Zero Point Compensation Range	15
Table 2.3	Output Resolution versus Sample Rate	16
Table 2.4.	Output configurations overview	18
Table 2.5.	Analog output configuration	19
Table 4.1.	Pin Configuration	23



1 Electrical Characteristics

1.1. Absolute Maximum Ratings

Table 1.1 Absolute Maximum Ratings

No.	Parameter	Symbol	Conditions	Min	Typ	Max	Unit
1.1.1	Digital Supply Voltage	VDD _{AMR}	To VSS	-0.3		6.5	V DC
1.1.2	Analog Supply Voltage	VDDA _{AMR}	To VSS	-0.3		6.5	V DC
1.1.3	Voltage at all analog and digital I/O – Pins	V _{A_I/O} , V _{D_I/O}	Exception see 1.1.4	-0.3		VDDA +0.3	V DC
1.1.4	Voltage at Pin FBP	V _{FBP_AMR}	4 mA to 20mA – Interface	-1.2		VDDA +0.3	V DC
1.1.5	Storage temperature	T _{STG}		-45		150	°C

1.2. Operating Conditions ¹ (Voltages related to VSS)

Table 1.2 Operating Conditions

No.	Parameter	Symbol	Conditions	Min	Typ	Max	Unit
1.2.1	Ambient temperature advanced performance	T _{ADV}	T _{QI} = -25 to 85°C T _{QC} = 0 to 70°C	-25		85	°C
1.2.2.1	Ambient temperature Automotive range	T _{AMB_TQA}		-40		125	°C
1.2.2.2	Ambient temperature Extended automotive range	T _{AMB_TQE}	Operation life time < 1000h @ 125 to 150°C	-40		150	°C
1.2.3	Ambient temperature EEPROM programming	T _{AMB_EEP}		-25		85	°C
1.2.4	EEPROM programming cycles					100	
1.2.5	Data retention (EEPROM)		Averaged temp < 85°C			15	a
1.2.6	Analog Supply Voltage	VDDA	Ratiometric mode	2.7		5.5	V DC
1.2.7	Analog Supply Voltage advanced performance	VDDA _{ADV}	Ratiometric mode	4.5		5.5	V DC
1.2.8	Digital Supply Voltage	VDD	External powered	- 2.7		1.05 -	VDDA V DC
1.2.9	External Supply Voltage	V _{SUPP}	Voltage regulator mode with ext. JFET	VDDA + 2V		²	V DC
1.2.10	Common mode input range	V _{IN_CM}	Depends on gain adjust, refer chapter 2.3.1	0.21		0.76	VADC_ REF
1.2.11	Input Voltage Pin FBP	V _{IN_FBP}		-1		VDDA	V DC

¹ Default configuration: 2nd order AD-conversion, 13Bit Resolution, gain >=210, f_{clk} <=2.25MHz

² Maximum depending on breakdown voltage of external JFET, notice application hints in related application note.

ZSC31050

Advanced Differential Sensor Signal Conditioner



No.	Parameter	Symbol	Conditions	Min	Typ	Max	Unit
1.2.12	Sensor Bridge Resistance	R _{BR} R _{BR_CL}	Full temperature range Current Loop-IF 4 to 20mA	3.0 ¹ 5.0		25.0 25.0	kΩ kΩ
1.2.13	Reference Resistor for Bridge Current Source*	RBR_REF	Leads to IBR = VDDA / (16·RBR_REF)	0.07			RBR
1.2.14	Stabilization Capacitor*	CVDDA	Between VDDA and VSS, external	50	100	470	nF
1.2.15	VDD Stabilization Capacitor*	CVDD	Between VDD and VSS, external	0 ²	100	470	nF
1.2.16	Maximum allowed load capacitance at OUT ³	CL_OUT	Output Voltage mode			50	nF
1.2.17	Minimum allowed load resistance	RL_OUT	Output Voltage mode	2			kΩ
1.2.18	Maximum allowed load capacitance at VGATE	CL_VGATE	Summarized to all potentials			10	nF

1.3. Build In Characteristics

Table 1.3 Build In Characteristics

No.	Parameter	Symbol	Conditions	Min	Typ	Max	Unit
1.3.1	Selectable Input Span, Pressure Measurement	V _{IN_SP}	Refer chapter 2.3.1	2		280	mV/V
1.3.2	Analog Offset Comp Range (6 Bit setting)		ADJREF:BCUR=7	-20 -25		20 25	count
1.3.3	A/D Resolution	r _{ADC}	3 Bit setting ⁴	9		15	Bit
1.3.4	D/A Resolution	r _{DAC}	@ analogue output		11		Bit
1.3.5	PWM - Resolution	r _{PWM}		9		12	Bit
1.3.6	Bias current for external temperature diodes	I _{TS}		8	18	40	μA
1.3.7	Sensitivity internal temperature diode	ST _{T_SI}	Raw values - without conditioning	2800	3200	3600	ppm f.s. /K
1.3.8	Clock frequency	f _{CLK}	guaranteed adjustment range	1*	2	4*	MHz

* No measurement in mass production, parameter is guaranteed by design and/or quality observations

¹ No limitations with an external connection between VDDA and VBR

² Lower stabilization capacitors can increase noise level at the output

³ If used, consider special requirements of ZACwire™ single wire interface stated in "Functional Description" chapter 4.3

⁴ Resolution of 15bit is not applicable for 1st order ADC and not recommended for sensors with high nonlinearity behavior



1.3.1. Cycle Rate versus A/D-Resolution *

(linear related to master clock frequency¹ - values calculated at exact 2 MHz)

Table 1.4 Cycle Rate versus A/D-Resolution

ADC Order O _{ADC}	Resolution r _{ADC}	Conversion Cycle f _{cyc}	
		f _{CLK} =2MHz	f _{CLK} =2.25MHz
	[Bit]	[Hz]	[Hz]
1	9	1302	1465
	10	781	879
	11	434	488
	12	230	259
	13	115	129
	14	59	67
2	11	3906	4395
	12	3906	4395
	13	1953	2197
	14	1953	2197
	15	977	1099

1.3.2. PWM Frequency *

Table 1.5 PWM Frequency

PWM Resolution r _{PWM} [Bit]	PWM Freq./Hz at 2 MHz Clock ¹				PWM Freq./Hz at 2.25 MHz Clock ²			
	Clock Divider				Clock Divider			
	1	0,5	0,25	0,125	1	0,5	0,25	0,125
9	3906	1953	977	488	4395	2197	1099	549
10	1953	977	488	244	2197	1099	549	275
11	977	488	244	122	1099	549	275	137
12	488	244	122	61	549	275	137	69

* No measurement in mass production, parameter is guaranteed by design and/or quality observations

¹ Internal RC – Oscillator: coarse adjustment to 1, 2 and 4 MHz, fine tuning +/- 25% , external clock is also possible

² Internal RC – Oscillator: coarse adjustment to 1.125, 2.25 and 4.5 MHz, fine tuning +/- 25% , external clock is also possible



1.4. Electrical Parameters ¹ (Voltages related to VSS)

Table 1.6 Electrical Parameters

No.	Parameter	Symbol	Conditions	Min	Typ	Max	Unit
1.4.1. Supply / Regulation							
1.4.1.1	Supply current	I _{SUPP}	Without bridge and load current, f _{CLK} ≤ 2.4MHz, Bias-Adjust ≤ 4		2.5	4	mA
1.4.1.2	Supply current for current loop	I _{SUPP_CL}	Without bridge current, f _{CLK} ≤ 1.2MHz, Bias-Adjust ≤ 1 ²		2.0	2.75	mA
1.4.1.2	Temperature Coeff. Voltage Reference	TC _{REF}		-200	±50	200	ppm/K
1.4.2. Analog Front End							
1.4.2.1	Parasitic differential input offset current	I _{IN_OFF}	Temp. range 5.2.2., T _{ADV}	-2 to -10		2 to 10	nA
1.4.3. DAC & Analog Output (Pin OUT)							
1.4.3.1	Output signal range	V _{OUT_SR}	Voltage Mode, R _{LOAD} > 2KΩ V _{DDA} _{ADV} , T _{ADV} ³	0.025		0.975	V _{DDA}
1.4.3.2	Output DNL	DNL _{OUT}	V _{DDA} _{ADV} , T _{ADV}			0.95	LSB
1.4.3.3	Output INL	INL _{OUT}	⁴			4	LSB
1.4.3.4	Output slew rate *	SR _{OUT}	Voltage mode, C _L < 20nF, using conditions of 1.4.3.1	0.1			V/μs
1.4.3.5	Short circuit current *	I _{OUT_max}		5	10	20	mA
1.4.3.6	Addressable output signal range	V _{OUT_ADR}	2048 steps	0		1	V _{DDA}
1.4.4. PWM Output (Pin OUT, IO1)							
1.4.4.1	PWM high voltage	V _{PWM_H}	R _L > 10 kΩ	0.9			V _{DDA}
1.4.4.2	PWM low voltage	V _{PWM_L}	R _L > 10 kΩ			0.1	V _{DDA}
1.4.4.3	PWM output slew rate **	SR _{PWM}	C _L < 1nF	15			V/μs
1.4.5. Temperature Sensors (Pin IR_TEMP)							
1.4.5.1	Sensitivity external diode / resistor meas.	ST _{TS_E}	At r _{ADC} = 13 Bit	75		210	μV/LSB
1.4.6. Digital Outputs (IO1, IO2, OUT in digital mode)							
1.4.6.1	Output-High-Level	V _{DOUT_H}	R _L > 1 kΩ	0.9			V _{DDA}
1.4.6.2	Output-Low-Level	V _{DOUT_L}	R _L > 1 kΩ			0.1	V _{DDA}
1.4.6.3	Output Current *	I _{DOUT}		4			mA

¹ Default configuration: 2nd order AD-conversion, 13Bit Resolution, gain ≥ 210, f_{clk} ≤ 2.25MHz

² Recommended bias adjust ≤ 4, notice application hints and power consumption adjust constraints in related application note

^{*} No measurement in mass production, parameter is guaranteed by design and/or quality observations

³ Derated performance in lower part of supply voltage range (2.7 to 3.3V): 2.5 to 5%V_{DDA} & 95 to 97.5%V_{DDA}

⁴ Output linearity and accuracy can be enhanced by additional analog output stage calibration

ZSC31050

Advanced Differential Sensor Signal Conditioner



1.4.7. System Response							
1.4.7.1	Startup time ¹	t _{STA}	Power On to 1 st measure result at output	2		5	ms
1.4.7.2	Response time *	t _{RESP}	66% jump, refer 2.3.4 for f _{CON}	1.66	2.66	3.66	1/f _{CON}
1.4.7.3	Overall accuracy (deviation from ideal line including INL, gain and offset errors) ²	AC _{OUT}	T _{ADV} & VDDA _{ADV} T _{AMB_TQA} & VDDA _{ADV} @ current-loop-OUT & T _{ADV} & VDDA _{ADV} (refer also application note AN05 of ZSC31050)			0.10 0.25 0.50	% % %
1.4.7.4	Analog Output Noise Peak-to-Peak *	V _{NOISE, PP}	Shorted inputs, gain<=210 bandwidth ≤ 10kHz			10	mV
1.4.7.5	Analog Output Noise RMS *	V _{NOISE, RMS}	Shorted inputs, gain<=210 bandwidth ≤ 10kHz			3	mV
1.4.7.6	Ratiometricity Error	RE _{OUT_5V} RE _{OUT_3V}	±5% respect. 1000ppm ±10% (5V) ±5% respect. 2000ppm ±10% (3V)			500 1000	ppm ppm

¹ OWI – start window disabled, according default configuration (depends on resolution and configuration - start routine begins approximately 0.8ms after power on)

² Accuracy better than 0.5% requires offset and gain calibration for the analog output stage, Parameter only for ratiometric output. Refer ZSC31050 Functional Description for other output configurations.

* No measurement in mass production, parameter is guaranteed by design and/or quality observations



1.5. Interface Characteristics

Table 1.7. Interface Characteristics

No.	Parameter	Symbol	Conditions	Min	Typ	Max	Unit
1.5.1. Multiport Serial Interfaces (I ² C, SPI)							
1.5.1.1	Input-High-Level	V _{I2C_IN_H}		0.7		1	VDDA
1.5.1.2	Input-Low-Level	V _{I2C_IN_L}		0		0.3	VDDA
1.5.1.3	Output-Low-Level	V _{I2C_OUT_L}				0.1	VDDA
1.5.1.4	Load capacitance @ SDA	C _{SDA}				400	pF
1.5.1.5	Clock frequency SCL ¹	f _{SCL}	f _{CLK} ≥ 2MHz			400	kHz
1.5.1.6	Pull-up Resistor	R _{I2C_PU}		500			Ω
1.5.1.7	Input capacitance (each pin)	C _{I2C_IN}	valid for SPI as well			10	pF
1.5.2. One Wire Serial Interface (ZACwire™)							
1.5.2.1	OWI start window	t _{OWI_start}			20		ms
1.5.2.2	Pull-up resistance master	R _{OWI_PU}		330			Ω
1.5.2.3	OWI load capacitance	C _{OWI_LOAD}	20μs < t _{OWI_BIT} < 100μs			0.08	t _{OWI_BIT} / R _{OWI_PU}
1.5.2.4	Voltage level Low	V _{OWI_L}				0.2	VDDA
1.5.2.5	Voltage level High	V _{OWI_H}		0.75			VDDA

¹ Internal clock frequency f_{CLK} has to be in minimum 5 times higher than communication clock frequency



2 Circuit Description

2.1. Signal Flow

The ZSC31050's signal path is partly analog (blue) and partly digital (red). The analog part is realized differential – this means internal is the differential bridge sensor signal also handled via two signal lines, which are rejected symmetrically around a common mode potential (analog ground = $V_{DDA}/2$).

Consequently it is possible to amplify positive and negative input signals, which are located in the common mode range of the signal input.

Figure 2.1 Block Diagram of the ZSC31050

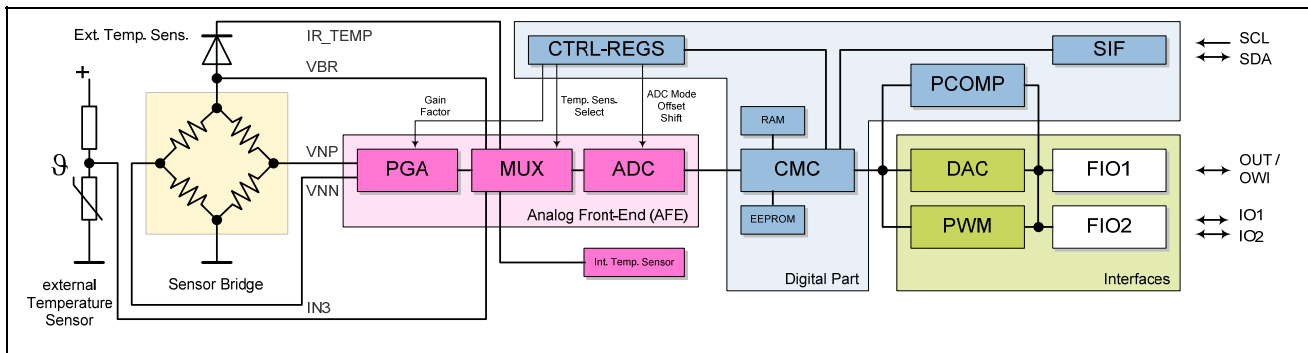

PGA	Programmable Gain Amplifier
MUX	Multiplexer
ADC	Analog-to-Digital Converter
CMC	Calibration Microcontroller
DAC	Digital-to-Analog Converter
FIO1	Flexible I/O 1: Analog Out (voltage/current), PWM2, ZACwire™ (one-wire-interface)
FIO2	Flexible I/O 2: PWM1, SPI Data Out, SPI Slave Select, Alarm1, Alarm2
SIF	Serial interface: I ² C Data I/O, SPI Data In, Clock
PCOMP	Programmable Comparator
EEPROM	Non Volatile Memory for Calibration Parameters and Configuration
TS	On-chip Temperature Sensor (pn-junction)
ROM	Memory for Correction Formula and –Algorithm
PWM	PWM Module

The differential signal from the bridge sensor is pre-amplified by the programmable gain amplifier (PGA). The Multiplexer (MUX) transmits the signals from bridge sensor, external diode or separate temperature sensor to the ADC in a certain sequence (instead of the temperature diode the internal pn-junction (TS) can be used optionally). Afterwards the ADC converts these signals into digital values.

The digital signal correction takes place in the calibration micro-controller (CMC). It is based on a special correction formula located in the ROM and on sensor-specific coefficients (stored into the EEPROM during calibration). Dependent on the programmed output configuration the corrected sensor signal is output as analog value, as PWM signal or in digital format (SPI, I²C and ZACwire™). The output signal is provided at 2 flexible I/O modules (FIO) and at the serial interface (SIF). The configuration data and the correction parameters can be programmed into the EEPROM via the digital interfaces.



The modular circuit concept enables fast custom designs varying these blocks and, as a result, functionality and die size.

2.2. Application Modes

For each application a configuration set has to be established (generally prior to calibration) by programming the on-chip EEPROM regarding to the following modes:

- **Sensor channel**
 - Sensor mode: ratiometric voltage or current supply mode.
 - Input range: The gain of the analog front end has to be chosen with respect to the maximum sensor signal span and to this has also adjusted the zero point of the ADC
 - Additional offset compensation: The extended analog offset compensation has to be enabled if required, e.g. if the sensor offset voltage is near to or larger than the sensor span.
 - Resolution/response time: The A/D converter has to be configured for resolution and conversion scheme (1st or 2nd order). These settings influence the sampling rate, signal integration time and this way the noise immunity.
 - Ability to invert the sensor bridge inputs
- **Analog output**
 - Choice of output method (voltage value, current loop or PWM) for output register 1.
 - Optional choice of additional output register 2: PWM via IO1 or alarm out module via IO1/2.
- **Digital communication:** The preferred protocol and its parameter have to be set.
- **Temperature**
 - The **temperature measure source** for the temperature correction has to be chosen.
 - The temperature measure source T1 sensor type for the temperature correction has to be chosen (only T1 is usable for correction!!!)
 - Optional: the **temperature measure channel** as the second output has to be chosen.
- **Supply voltage:** For non-ratiometric output the voltage regulation has to be configured.

Note: Not all possible combinations of settings are allowed (see section 2.5).

The calibration procedure must include

- Set of coefficients of calibration calculation

and, depending on configuration,

- Adjustment of the extended offset compensation,
- Zero compensation of temperature measurement,
- Adjustment of the bridge current

and, if necessary,

- Set of thresholds and delays for the alarms and the reference voltage.



2.3. Analog Front End (AFE)

The analog front end consists of the programmable gain amplifier (PGA), the multiplexer (MUX) and the analog-to-digital converter (ADC).

2.3.1. Programmable Gain Amplifier (PGA)

The following tables show the adjustable gains, the processable sensor signal spans and the allowed common mode range.

Table 2.1 Adjustable gains, resulting sensor signal spans, and common mode ranges

No.	PGA Gain a_{IN}	Gain Amp1	Gain Amp2	Gain Amp3	Max. span V_{IN_SP} in mV/V	Input range V_{IN_CM} in % V_{DDA} ¹³
1	420	30	7	2	2	43 - 57
2	280	30	4,66	2	3	40 - 59
3	210	15	7	2	4	43 - 57
4	140	15	4,66	2	6	40 - 59
5	105	15	3,5	2	8	38 - 62
6	70	7,5	4,66	2	12	40 - 59
7	52,5	7,5	3,5	2	16	38 - 62
8	35	3,75	4,66	2	24	40 - 59
9	26,3	3,75	3,5	2	32	38 - 62
10	14	1	7	2	50	43 - 57
11	9,3	1	4,66	2	80	40 - 59
12	7	1	3,5	2	100	38 - 62
13	2,8	1	1,4	2	280	21 - 76

2.3.2. Extended Zero Point Compensation (XZC)

The ZSC31050 supports two methods of sensor offset cancellation (zero shift):

- Digital offset correction
- XZC – an analog cancellation for large offset values (up to approx 300% of span)

The digital sensor offset correction will be processed at the digital signal correction/conditioning by the CMC. The analog sensor offset pre-compensation will be needed for compensation of large offset values, which would be overdrive the analog signal path by uncompensated gaining. For analog sensor offset pre-compensation a compensation voltage will be added in the analog pre-gaining signal path (coarse offset removal). The analog offset compensation in the AFE can be adjusted by 6 EEPROM bits. It allows an analog zero point shift up to 300% of the processable signal span.

The zero point shift of the temperature measurements can also be adjusted by 6 EEPROM bits ($Z_{XZC} = -20 \dots +20$) and is calculated by:

$$\frac{V_{XZC}}{V_{DDBR}} = \frac{k \cdot Z_{XZC}}{20 \cdot a_{IN}}$$

¹³ Bridge in voltage mode, refer "ZSC31050 Functional description" for usable input signal/common mode range at bridge in current mode



Table 2.2 Extended Zero Point Compensation Range

PGA Gain a_{IN}	Max. Span V_{IN_SP} [mV/V]	Calculation Factor k	Offset Shift per Step [% Full Span]	Approx. Maximum Offset Shift [mV/V]	Approx. Maximum Shift [% V_{IN_SP}] (@ ± 20 Steps)
420	2	3,0	15%	+/- 7	330
280	3	1,833	9%	+/- 6	200
210	4	3,0	15%	+/- 14	330
140	6	1,833	9%	+/- 12	200
105	8	1,25	6%	+/- 12	140
70	12	1,833	9%	+/- 24	200
52,5	16	1,25	6%	+/- 22	140
35	24	1,833	9%	+/-48	200
26,3	32	1,25	6%	+/- 45	140
14	50	3,0	15%	+/- 180	330
9,3	80	1,833	9%	+/- 160	200
7	100	1,25	6%	+/- 140	140
2,8	280	0,2	1%	+/- 60	22

Note: Z_{ZC} can be adjusted in range -31 to 31 , parameters are guaranteed only in range -20 to 20 .

2.3.3. Measurement Cycle realized by Multiplexer

The Multiplexer selects, depending on EEPROM settings, the following inputs in a certain sequence.

- Internal offset of the input channel measured by input short circuiting
- Bridge temperature signal measured by external and internal diode (pn-junction)
- Bridge temperature signal measured by bridge resistors
- Temperature measurement by external thermistor
- Pre-amplified bridge sensor signal

The complete measurement cycle is controlled by the CMC. The cycle diagram at the right shows its principle structure.

The EEPROM adjustable parameters are:

- Pressure measurement count,
 $PMC = \langle 1, 2, 4, 8, 16, 32, 64, 128 \rangle$
- Temperature 2 measurement enable,
 $T2E = \langle 0, 1 \rangle$

After Power ON the start routine is called. It contains the pressure and auto zero measurement. When enabled it measures the temperature and its auto zeros.

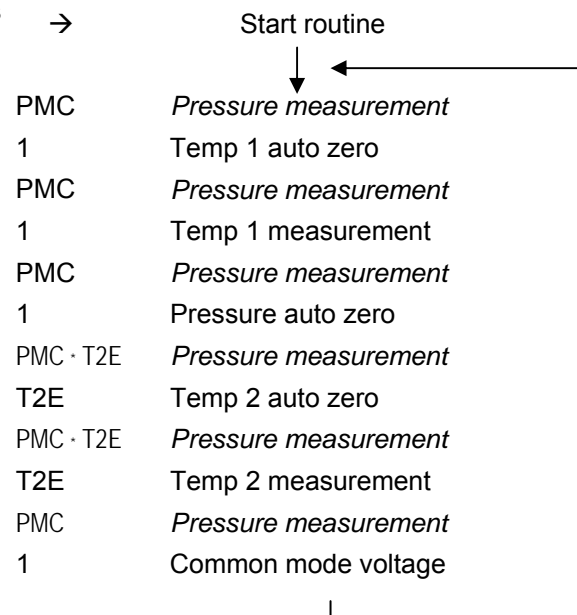

Figure 2.2. Measurement Cycle ZSC31050



2.3.4. Analog-to-Digital Converter

The ADC is a charge balancing converter in full differential switched capacitor technique. It can be used as first or second order converter:

In the **first order** mode it is inherently monotone and insensitive against short and long term instability of the clock frequency. The conversion cycle time depends on the desired resolution and can be roughly calculated by:

$$t_{CYC_1} = 2^{r_{ADC}} [\mu s]$$

The available ADC-resolutions are $r_{ADC} = \langle 9, 10, 11, 12, 13, 14 \rangle$.

In the **second order** mode two conversions are stacked with the advantage of much shorter conversion cycle time and the drawback of a lower noise immunity caused by the shorter signal integration period. The conversion cycle time at this mode is roughly calculated by:

$$t_{CYC_2} = 2^{\left(\frac{r_{ADC}+3}{2}\right)} [\mu s]$$

The available ADC-resolutions are $r_{ADC} = \langle 11, 12, 13, 14, 15 \rangle$.

The result of the AD conversion is a relative counter result corresponding to the following equation

$$Z_{ADC} = 2^{r_{ADC}} \cdot \left(\frac{V_{ADC_DIFF} + V_{ADC_OFF}}{V_{ADC_REF}} - 1 + RS_{ADC} \right)$$

- Z_{ADC} : Number of counts (result of the conversion)
- V_{ADC_DIFF} : Differential input voltage of ADC (= $a_{IN} \cdot V_{IN_DIFF}$)
- V_{ADC_REF} : Reference voltage of ADC (= VBR or VDDA)
- RS_{ADC} : Digital ADC Range Shift ($RS_{ADC} = 1/2, 3/4, 7/8, 15/16$, controlled by the EEPROM content)

With the RS_{ADC} value a sensor input signal can be shifted in the optimal input range of the ADC.

The Pin <VBR>-potential is used in "VBR=VREF" mode as AD converters reference voltage V_{ADC_REF} . Sensor bridges with no ratiometric behavior (e.g. temperature compensated bridges), which are supplied by a constant current, requires VDDA potential as V_{ADC_REF} and this can be adjusted by in configuration. If these mode is enabled, XZC can't be used (adjustment=0), but it has to be enabled (refer calculation sheet "ZSC31050_Bridge_Current_Excitation_Rev*.xls" for details).

Note: The AD conversion time (sample rate) is only a part of a whole signal conditioning cycle.

Table 2.3 Output Resolution versus Sample Rate

ADC Order O_{ADC}	Maximum Output Resolution				Sample Rate f_{CON}	
	r_{ADC}^{14}	Digital-OUT	Analog-OUT	r_{PWM}	$f_{CLK}=2MHz$	$f_{CLK}=2.25MHz$
	[Bit]	[Bit]	[Bit]	[Bit]	[Hz]	[Hz]
1	9	9	9	9	1302	1465
	10	10	10	10	781	879
	11	11	11	11	434	488
	12	12	11	12	230	259
	13	13	11	12	115	129
	14	14	11	12	59	67

¹⁴ ADC resolution should be 1 to 2 bits higher than applied Output Resolution

ZSC31050

Advanced Differential Sensor Signal Conditioner



ADC Order O _{ADC}	Maximum Output Resolution				Sample Rate f _{CON}	
	r_{ADC}^{14}	Digital-OUT	Analog-OUT	r_{PWM}	f _{CLK} =2MHz	f _{CLK} =2.25MHz
	[Bit]	[Bit]	[Bit]	[Bit]	[Hz]	[Hz]
2	10	10	10	10	3906	4395
	11	11	11	11	3906	4395
	12	12	11	12	3906	4395
	13	13	11	12	1953	2197
	14	14	11	12	1953	2197
	15	15	11	12	977	1099

2.4. System Control

The system control has the following features:

- Control of the I/O relations and of the measurement cycle regarding to the EEPROM-stored configuration data
- 16 bit correction calculation for each measurement signal using the EEPROM stored calibration coefficients and ROM-based algorithms
- Started by internal POC, internal clock – generator or external clock
- For safety improvement the EEPROM data are proved with a signature within initialization procedure, the registers of the CMC are steadily observed with a parity check. Once an error is detected, the error flag of the CMC is set and the outputs are driven to a diagnostic value

Note: The conditioning includes up to third order sensor input correction. The available adjustment ranges depend on the specific calibration parameters, a detailed description will be issued later. To give a rough idea: Offset compensation and linear correction are only limited by the loose of resolution it will cause, the second order correction is possible up to about 20% full scale difference to straight line, third order up to about 10% (ADC resolution = 13bit). The temperature calibration includes first and second order correction and should be fairly sufficient in all relevant cases. ADC resolution influences also calibration possibilities – 1 bit more resolution reduces calibration range by approximately 50%.



2.5. Output Stage

Table 2.4. Output configurations overview

No.	Used SIF		Used I/O pins			
	I2C	SPI	OUT	IO1	IO2	SDA
1	X					Data I/O
2	X			ALARM1		Data I/O
3	X				ALARM2	Data I/O
4	X			ALARM1	ALARM2	Data I/O
5	X			PWM1		Data I/O
6	X			PWM1	ALARM2	Data I/O
7	X		Analog			Data I/O
8	X		Analog	ALARM1		Data I/O
9	X		Analog		ALARM2	Data I/O
10	X		Analog	ALARM1	ALARM2	Data I/O
11	X		Analog	PWM1		Data I/O
12	X		Analog	PWM1	ALARM2	Data I/O
13	X		PWM2			Data I/O
14	X		PWM2	ALARM1		Data I/O
15	X		PWM2		ALARM2	Data I/O
16	X		PWM2	ALARM1	ALARM2	Data I/O
17	X		PWM2	PWM1		Data I/O
18	X		PWM2	PWM1	ALARM2	Data I/O
19		X		Data out	Slave select	Data in
20		X		Data out	Slave select	Data in
			ALARM1	-	-	
21		X		Data out	Slave select	Data in
			PWM1	-	-	
22		X	Analog	Data out	Slave select	Data in
23		X	Analog	Data out	Slave select	Data in
				ALARM1	-	-
24		X	Analog	Data out	Slave select	Data in
				PWM1	-	-
25		X	PWM2	Data out	Slave select	Data in
26		X	PWM2	Data out	Slave select	Data in
				ALARM1	-	-
27		X	PWM2	Data out	Slave select	Data in
				PWM1	-	-

The ZSC31050 provides the following I/O pins: OUT, IO1, IO2 and SDA.

Via these pins the following signal formats can be output: Analog (voltage/current), PWM, Data (SPI/I²C), Alarm.

The following values can be provided at the O/I pins: bridge sensor signal, temperature signal 1, temperature signal 2, and alarm.

Note:

The Alarm signal only refers to the bridge sensor signal, but never to a temperature signal.

Due to the necessary pin sharing there are restrictions to the possible combinations of outputs and interface connections.

The table beside gives an overview about possible combinations.

Note:

In the SPI mode the pin IO2 is used as Slave Select. Thus no Alarm 2 can be output in this mode.



2.5.1. Analog Output

For the analog output 3 registers of 15 bit depth are available, which can store the actual pressure and the results of temperature measurement 1 and 2. Each register can be independently switched to one of two output slots connected to the Pin OUT and IO1 respectively. In these output slots different output modules are available according to the following table:

Table 2.5. Analog output configuration

Output slot:	OUT	IO1
Voltage	x	
PWM	x	x

The voltage module consists of an 11bit resistor string – DAC with buffered output and a subsequent inverting amplifier with class AB rail-to-rail OpAmp. The two feedback nets are connected to the Pins FBN and FBP. This structure offers wide flexibility for the output configuration, for example voltage output and 4 mA to 20 mA current loop output. To short circuit the analog output against VSS or VDDA does not damage the ZSC31050.

The PWM module provides pulse streams with signal dependent duty cycle. The PWM – frequency depends on resolution and clock divider. The maximum resolution is 12 bit, the maximum PWM – frequency is 4 kHz (9 bit). If both second PWM and SPI protocol are activated, the output pin IO1 is shared between the PWM output and the SPI_SDO output of the serial interface (interface communication interrupts the PWM output).

2.5.2. Comparator Module (ALARM Output)

The comparator module consists of two comparator channels connectable to IO1 and IO2 respectively. Each of them can be independently programmed referring to the parameters threshold, hysteresis, switching direction and on/off – delay. Additionally a window comparator mode is available.

2.5.3. Serial Digital Interface

The ZSC31050 includes a serial digital interface which is able to communicate in three different communication protocols – I²C™, SPI™ and ZACwire™ (one wire communication).

In the SPI mode the pin IO2 operates as slave select input, the pin IO1 as data output.

Initializing Communication

After power-on the interface is for about 20ms (start window) in the state ZACwire. During the start window it is possible to communicate via the one wire interface (pin OUT).

Detecting a proper request inside the start window the interface stays in the state ZACwire. This state can be left by certain commands or a new power-on.

If during the start window no request happens, then the serial interface switches depending on EEPROM settings to I²C or SPI mode. The OUT pin is used as analog output or as PWM output (also depending on EEPROM settings). The start window can generally be disabled (or enabled) by a special EEPROM setting.

For detailed description of the serial interfaces see *ZSC31050 Functional Description*.

2.6. Voltage Regulator

For ratiometric applications 3V to 5V (±10%) the external supply voltage can be used for sensor element biasing. If an absolute analog output is desired then the internal voltage regulator with external power regulation element (JFET) can be used. The regulation is bandgap reference based and designed for an external supply voltage V_{SUPP} in the range of 7V to 40VDC. The internal supply and sensor bridge voltage can be varied between 3V and 5.5V in 4 steps with the voltage regulator.

ZSC31050

Advanced Differential Sensor Signal Conditioner



2.7. Watchdog and Error Detection

The ZSC31050 detects various possible errors. A detected error is signaled by changing in a diagnostic mode. In this case the analog output is set to the high or low level (maximum or minimum possible output value) and the output registers of the digital serial interface are set to a significant error code.

A watchdog oversees the continuous working of the CMC and the running measurement loop.

A check of the sensor bridge for broken wires is done permanently by two comparators watching the input voltage of each input [(VSSA + 0.5V) to (VDDA – 0.5V)]. Add on the common mode voltage of the sensor is watched permanently (sensor aging).

Different functions and blocks in digital part are watched like RAM-, ROM-, EEPROM- and Register content continuously, the document *ZSC31050 Functional Description* contains in chapter 1.3.4 a detailed description of all watched blocks and methods of messaging of errors.

ZSC31050

Advanced Differential Sensor Signal Conditioner



3 Application Circuit Examples

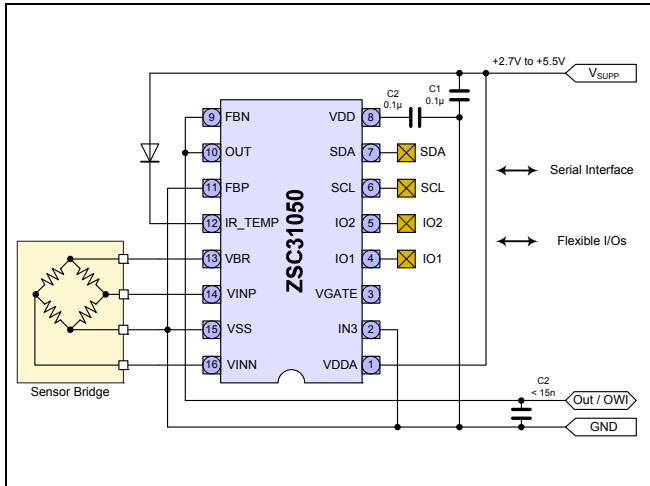

Figure 3.1 Example 1

Typical ratiometric measurement with voltage output, temperature compensation via external diode, internal VDD regulator and active sensor connection check (bridge must not be at VDDA)

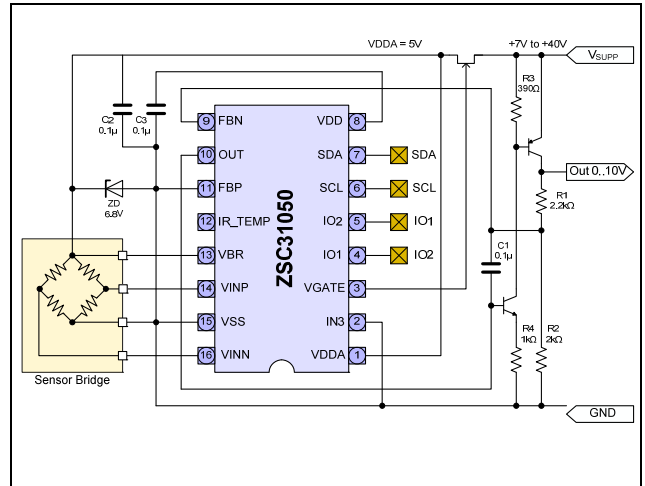

Figure 3.2 Example 2

0V to 10V output configuration, supply regulator (external JFET), temperature compensation via internal diode and bridge in voltage mode

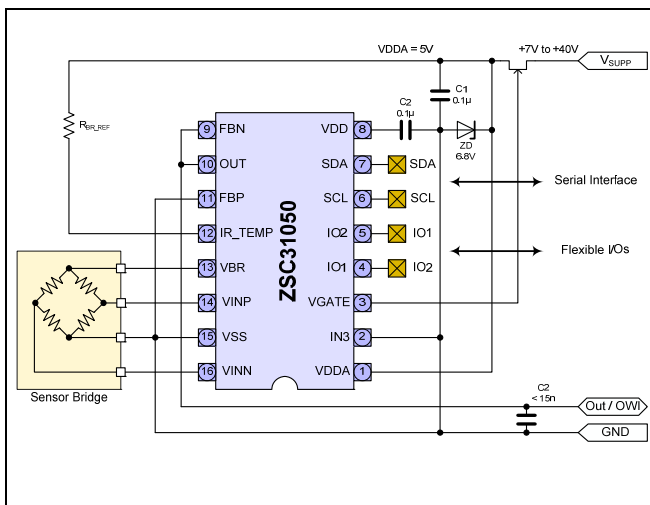

Figure 3.3 Example 3

Absolute voltage output, supply regulator (external JFET), constant current excitation of the sensor bridge, temperature compensation by bridge voltage drop measurement, internal VDD regulator without ext. capacitor

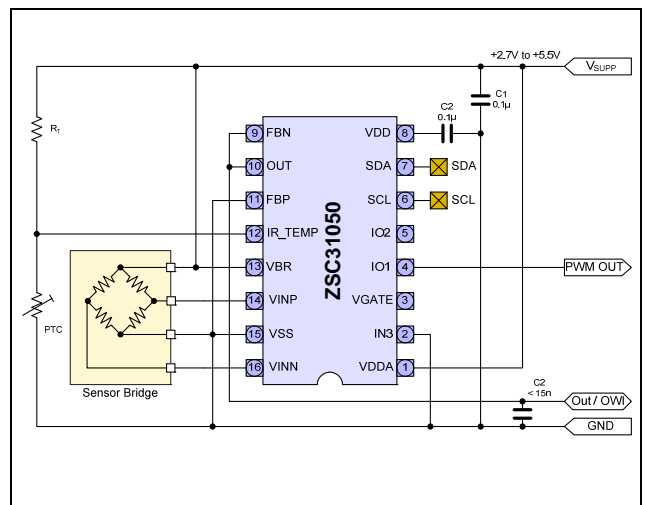

Figure 3.4 Example 4

Ratiometric bridge differential signal measurement, 3-wire connection for end of line calibration at pin OUT (ZACwire™), additional temperature measurement with external thermistor and PWM-output at pin IO1

ZSC31050

Advanced Differential Sensor Signal Conditioner

ZMDI®

The Analog Mixed Signal Company

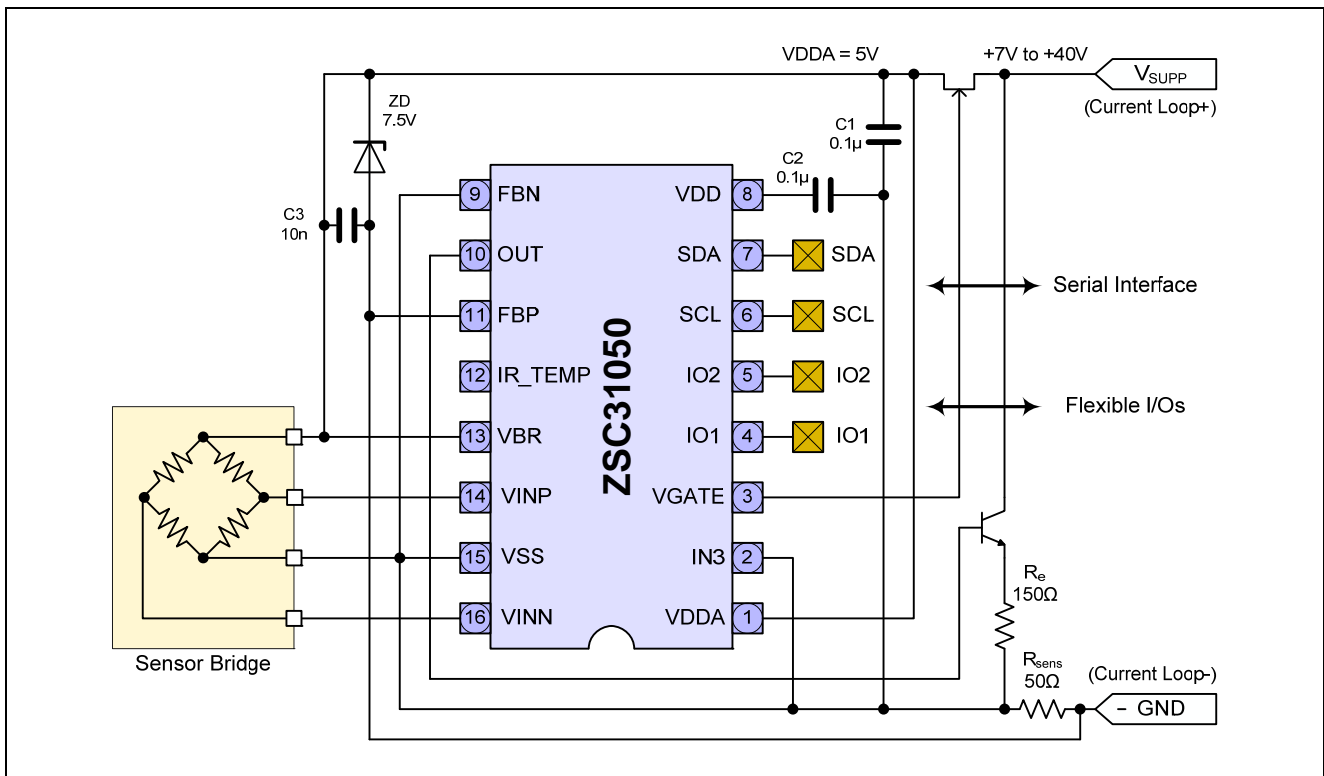

Figure 3.5 Example 5

Two-wire-(4 to 20) mA configuration [(7 to 40) V], temperature compensation via internal diode

Hints: It is possible to combine or split connectivity of different application examples. For VDD generation ZMDI recommends to use internal supply voltage regulator with external capacitor. Notice additional application notes for usage of supply voltage regulation property (non ratiometric mode) and current loop output mode.



4 ESD/Latch-Up-Protection

All pins have an ESD protection of >2000V (except the pins INN, INP and FBP with > 1200V) and a latch-up protection of $\pm 100\text{mA}$ or of +8V/ -4V (to VSS/VSSA) – refer chapter 5 for details and restrictions. ESD protection referred to the human body model is tested with devices in SSOP16 packages during product qualification. The ESD test follows the human body model with 1.5kOhm/100pF based on MIL 883, method 3015.7.

5 Pin Configuration and Package

Table 4.1. Pin Configuration

Pin	Name	Description	Remarks	Latch-up Related Application Circuit Restrictions and/or Remarks
1	VDDA	Positive analog supply voltage	Supply	
2	IN3	Resistive temp sensor IN & external clock IN	Analog IN	Free accessible (latch-up related)
3	VGATE	Gate voltage for external regulator FET	Analog OUT	Only connection to external FET
4	IO1	SPI data out & ALARM1 & PWM1 Output	Digital IO	Free accessibility
5	IO2	SPI chip select & ALARM2	Digital IO	Free accessibility
6	SCL	I ² C clock & SPI clock	Digital IN, pull-up	Free accessibility
7	SDA	Data IO for I ² C & data IN for SPI	Digital I/O, pull-up	Free accessibility
8	VDD	Positive digital supply voltage	Supply	Only capacitor to VSS allowed, otherwise no application access
9	FBN	Negative feedback connection output stage	Analog I/O	Free accessibility
10	OUT	Analog output & PWM2 Output & one wire interface i/o	Analog OUT & Digital I/O	Free accessibility
11	FBP	Positive feedback connection output stage	Analog I/O	Free accessibility
12	IR_TEMP	Current source resistor i/o & temperature diode in	Analog I/O	Circuitry secures potential inside of VSS-VDDA range, otherwise no application access
13	VBR	Bridge top sensing in bridge current out	Analog I/O	Only short to VDDA or connection to sensor bridge, otherwise no application access
14	VINP	Positive input sensor bridge	Analog IN	Free accessibility
15	VSS	Negative supply voltage	Ground	
16	VINN	Negative input sensor bridge	Analog IN	Free accessibility

ZSC31050

Advanced Differential Sensor Signal Conditioner



The standard package of the ZSC31050 is a SSOP16 (5.3mm body width) with lead-pitch 0.65mm:

Figure 4.1. Pin Configuration

Pin-Nr	Pin-Name		Pin-Name	Pin-Nr
9	FBN		VDD	8
10	OUT		SDA	7
11	FBP		SCL	6
12	IR_TEMP		IO2	5
13	VBR		IO1	4
14	VINP		VGATE	3
15	VSS		IN3	2
16	VINN		VDDA	1

6 Reliability

A reliability investigation according to the in-house non-automotive standard will be performed.

A fit rate < 5fit (temp=55°C, S=60%) is guaranteed. A typical fit rate of the C7A-technologie, which is used for ZSC31050, is 2.5fit.

7 Customization

For high-volume applications, which require an up- or downgraded functionality compared to the ZSC31050, ZMDI can customize the circuit design by adding or removing certain functional blocks.

For it ZMDI has a considerable library of sensor-dedicated circuitry blocks.

Thus ZMDI can provide a custom solution quickly. Please contact ZMDI for further information.

ZSC31050

Advanced Differential Sensor Signal Conditioner

ZMDI[®]

The Analog Mixed Signal Company



8 Ordering Information

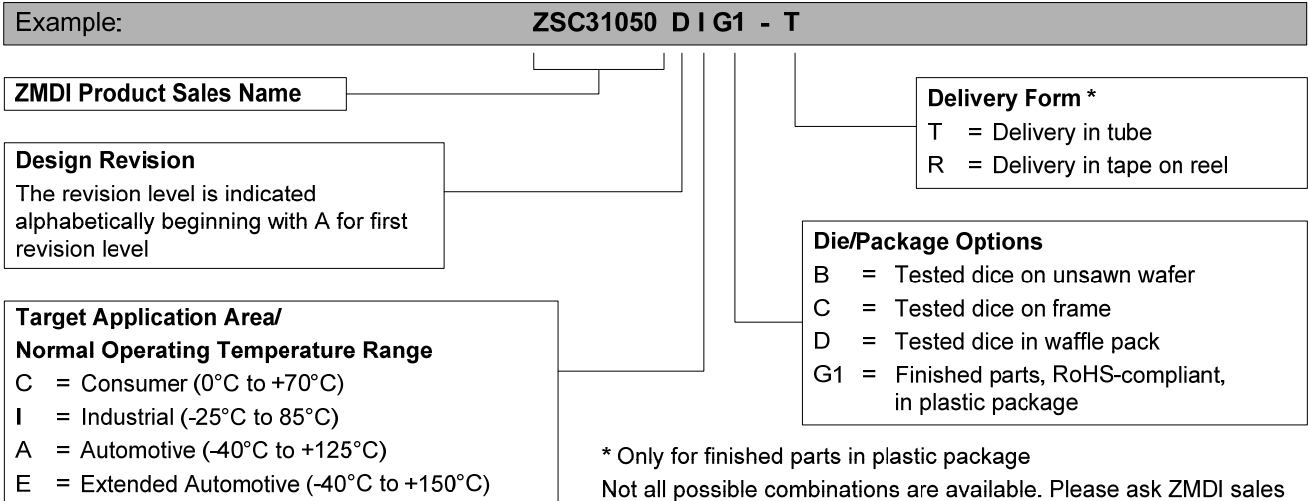

Product Sales Code	Description	Package
ZSC31050KIT Evaluation Kit V3.0	Modular evaluation and development boards for ZSC31050	KIT boards, IC samples, USB cable, DVD with software and documentation
ZSC31050 Mass Calibration System V1.1	Modular Mass Calibration System (MSC) for ZSC31050	MCS boards, cable, connectors, DVD with software and documentation

9 Related Documents

Document	File Name
ZSC31050 Feature Sheet	ZSC31050_Feature_Sheet_Rev_x_yy.pdf
ZSC31050 Functional Description	ZSC31050_FunctionalDescription_Rev_x_yy.pdf
ZSC31050 Evaluation Kit Description	ZSC31050_Application_Kit_Description_Rev_x_yy.pdf
ZSC31050 Development Status Report (including parts identification table)	

Visit ZMDI's website www.zmdi.com or contact your nearest sales office for the latest version of these documents.

ZSC31050

Advanced Differential Sensor Signal Conditioner

ZMDI[®]

The Analog Mixed Signal Company



10 Glossary

Term	Description
ADC	Analog-to-Digital Converter
AFE	Analog Front End
CMC	Calibration Microcontroller
CMOS	Complementary Metal Oxide Semiconductor
DNL	Differential Nonlinearity
ESD	Electrostatic Device
FIO	Flexible Input/Output
FSO	Full Scale Output
IC	Integrated Circuit
INL	Integral Nonlinearity
MUX	Multiplexer
PGA	Programmable Gain Amplifier
PMC	Pressure Measurement Count
POC	Power On Control
PWM	Pulse Width Modulation
SIF	Serial Interface
T2E	Temperature 2 Measurement
TS	Temperature Sensor
XZC	Extended Zero Point Compensation



11 Document Revision History

Revision	Date	Description
1.00	-	First release of document.
1.01	-	Headlines and footnotes at all pages updated
1.02	-	5.5.1.7 – Input capacitance of digital interface pins added
1.03	-	5.4 – note 4 “Default Configuration” added 5.4.7.3 – overall accuracy / values & conditions for current loop output inserted 6. – Reliability / fit rate values added
1.04	September 2009	adjust to new ZMDI template
1.05	October 2009	changed “Related Documents” and “Document Revision History” so that information is included in table change to ZMDI denotation
1.06	October 05, 2009	changed revision numbering in footer
1.07	November 30, 2009	<ul style="list-style-type: none"> • adjust to new ZMDI template • include “ZSC31050 Feature Sheet” at page 2&3 • add ordering codes for ZSC31050 and evaluation kits
1.08	February 16, 2010	<ul style="list-style-type: none"> • add unit at 1.4.1.2 and change symbol at 1.5.2.1 • add new design for block diagram and all application schematics • extend glossary • add CM/NOM information's in Table 2.4 • add new phone number for ZMD FAR EAST, Ltd. • Ordering codes adapted to SAP description
1.09	February 16, 2010	Spelling error of ZSC31050 on first FS page corrected
1.10	February 18, 2010	<ul style="list-style-type: none"> • changed revision numbering in footer • changed CD to DVD in Ordering Code • removed Die/Package Option “F” • correct different spelling and formatting issues
1.11	July 29, 2010	<ul style="list-style-type: none"> • changed “Application Circuit Examples” in Figure 3.1 and Figure 3.5 • add current consumption in feature sheet area • new style for equation in section 2.3.2 and 2.3.4 • correct calculation formula for Z_{ADC} in section 2.3.4 • rearrange of RS_{ADC} in section 2.3.4 → Functional Description used same fractions but opposite order • rename ZMD31050 to ZSC31050

ZSC31050

Advanced Differential Sensor Signal Conditioner

ZMDI[®]

The Analog Mixed Signal Company



Sales and Further Information		www.zmdi.com	sales@zmdi.com
Zentrum Mikroelektronik Dresden AG Grenzstrasse 28 01109 Dresden Germany Phone +49 (0)351.8822.7.772 Fax +49(0)351.8822.87.772	ZMD America, Inc. 8413 Excelsior Drive Suite 200 Madison, WI 53717 USA Phone +01 (608) 829-1987 Fax +01 (631) 549-2882	Zentrum Mikroelektronik Dresden AG, Japan Office 2nd Floor, Shinbashi Tokyu Bldg. 4-21-3, Shinbashi, Minato-ku Tokyo, 105-0004 Japan Phone +81.3.6895.7410 Fax +81.3.6895.7301	ZMD Far East, Ltd. 3F, No. 51, Sec. 2, Keelung Road 11052 Taipei Taiwan Phone +886.2.2377.8189 Fax +886.2.2377.8199
<small>DISCLAIMER: This information applies to a product under development. Its characteristics and specifications are subject to change without notice. Zentrum Mikroelektronik Dresden AG (ZMD AG) assumes no obligation regarding future manufacture unless otherwise agreed to in writing. The information furnished hereby is believed to be true and accurate. However, under no circumstances shall ZMD AG be liable to any customer, licensee, or any other third party for any special, indirect, incidental, or consequential damages of any kind or nature whatsoever arising out of or in any way related to the furnishing, performance, or use of this technical data. ZMD AG hereby expressly disclaims any liability of ZMD AG to any customer, licensee or any other third party, and any such customer, licensee and any other third party hereby waives any liability of ZMD AG for any damages in connection with or arising out of the furnishing, performance or use of this technical data, whether based on contract, warranty, tort (including negligence), strict liability, or otherwise.</small>			

Data Sheet July 29, 2010	© 2010 Zentrum Mikroelektronik Dresden AG — Rev. 1.11 All rights reserved. The material contained herein may not be reproduced, adapted, merged, translated, stored, or used without the prior written consent of the copyright owner. The information furnished in this publication is subject to changes without notice.	28 of 28
-----------------------------	---	----------