

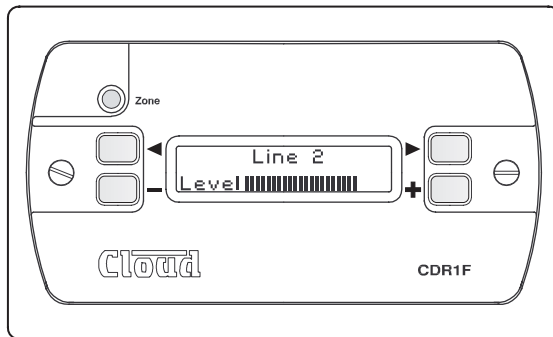

# CDR-1 & CDR1F

## Remote Control Units

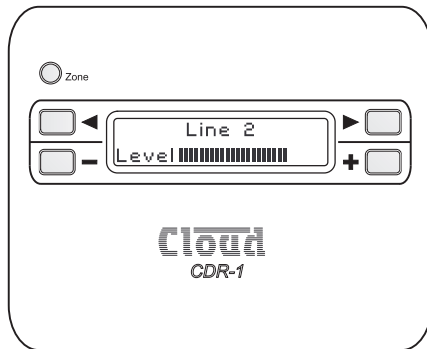

## Installation Guide



# Contents

<b>Introduction</b> .....	<b>4</b>
Model types.....	4
What's in the box .....	5
<b>Installation</b> .....	<b>5</b>
CDR networks and terminations.....	5
Cable length and DC power considerations .....	8
Wiring .....	9
Connecting and mounting – CDR-I .....	10
Connecting and mounting – CDR IF.....	13
<b>Configuration</b> .....	<b>15</b>
Installer mode.....	15
User mode .....	16
Engineer mode .....	16
Default settings.....	17
<b>Notes</b> .....	<b>18</b>

## Introduction

The CDR-I & CDRIF are remote control units specifically designed for use with the DCM-I. They may be fitted to standard electrical back boxes in whatever location is convenient in each zone.

### Model types

The CDR-I and CDRIF are electrically and operationally identical, but differ in their physical dimensions and mounting arrangements.

- The CDR-I is a surface-mounting unit, which may be mounted via its supplied mounting plate either to a single-gang back box, or directly to a suitable wall. Max. projection from the wall is 30 mm.
- The CDRIF is a flush-fitting panel which fits to a standard dual-gang back box. Max. projection from the wall is 10 mm.

Note: Where the term “CDR” is used in this manual, the text can be taken to apply to both the CDR-I and CDRIF. In the section describing mounting (where the two types differ), the full product names are used. An exception to this refers to the DCM-I’s remote control ports, which are described as **CDR-I PORTS**, to match the labeling on the DCM-I itself.

A zone may have one CDR, more than one, or none at all. The DCM-I can support up to 100 CDRs. CDRs are interconnected with standard CAT-5 UTP cable; units may be daisy-chained at will and/or connected individually back to the DCM-I’s four **CDR-I PORTS** using almost any wiring topology convenient for the installation.

The CDR provides the user with the following local control functions for the zone in which it is installed:

- Source selection
- Level control
- Group enable/disable (providing the zone has been defined as a group member)
- Local zone EQ adjustment (requires enabling on the DCM-I and entry of a key code)

An Installer Mode permits zone assignment and adjustment of other installation parameters.

## What's in the box

As well as this manual, the shipping carton should contain the items listed below. Please contact your Cloud dealer immediately if any of them are missing.

CDR-I	CDRIF
CDR-I Remote Control panel	CDRIF Remote Control panel
Mounting plate	2x M3.5 panhead screws
2x M3.5 x 20 panhead screws	2-pin 5 mm-pitch screw terminal connector
2x M3 x 8 countersunk head screws	

## Installation

### CDR networks and terminations

CDRs are connected to the DCM-I's CDR-I PORT sockets using standard unscreened CAT-5 cable and RJ45 connectors. It may be possible to use pre-made CAT-5 "patch cables" to connect any CDRs installed close to the DCM-I; otherwise CAT-5 cable and crimp RJ45 plugs should be used.

**Note:** All CAT-5 cabling should be wired "pin-to-pin"; "crossed" or "null" cables will not work.

CDRs may be connected to the DCM-I either by wiring them directly and individually, or by "daisy-chaining" them together. In most installations, a combination of these methods is likely to be the most convenient solution from the point of view of practical cabling. The diagrams on page 6 illustrate the types of wiring schemes that may be employed; almost any variation on these is permissible.

Note that the two types of CDR may be intermixed freely as the installation requires.

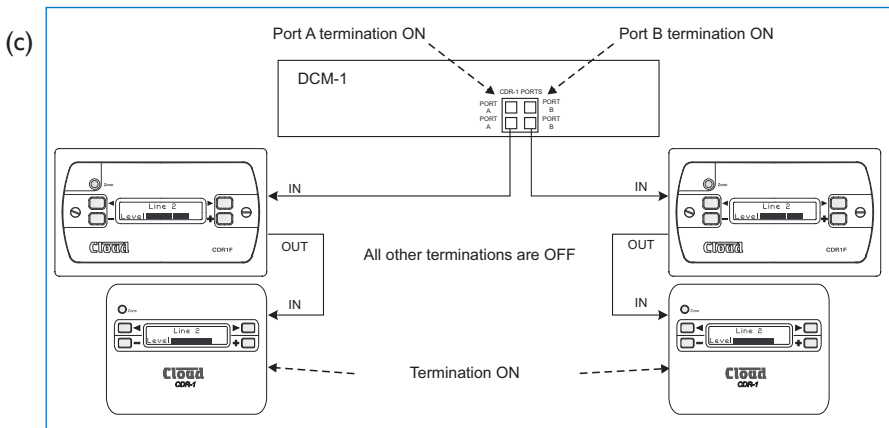
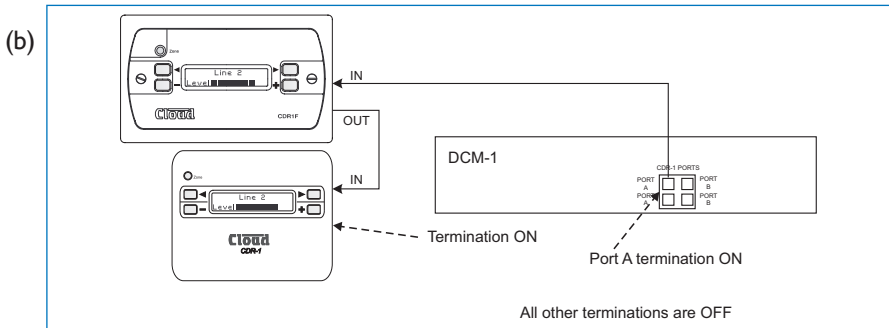
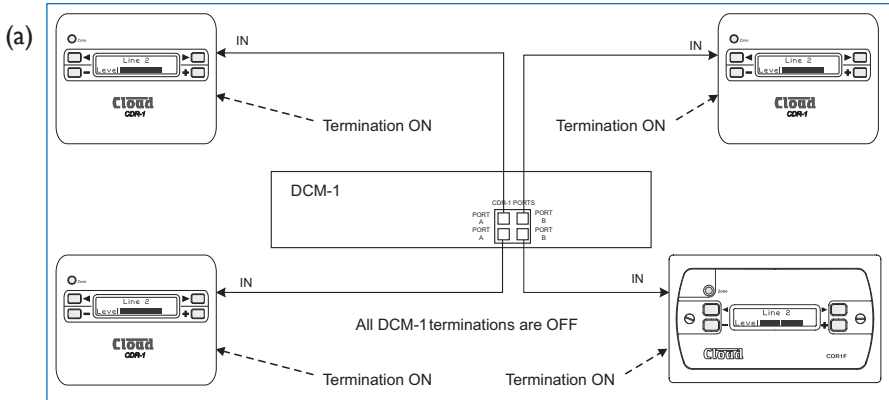

Diag. (a) shows four CDRs, each connected to one DCM-I port; (b) shows a single daisy-chain of two CDRs all on one port; c) shows two daisy-chains each of two CDRs using two ports. Note that in the diagrams there is deliberately no indication as to which zones any of the CDRs are in; this is because the system imposes no restriction on their physical location. CDRs in different zones may be in the same “chain”, and interconnections may be made purely on the basis of wiring convenience.

The CAT-5 wiring is essentially a data network, and as such, must be correctly terminated. Both the DCM-I and CDR are provided with means of setting their network terminations ON or OFF.

The rule governing terminations is:

- Devices (DCM-I or CDR) at the ends of a cable run must have their terminations set ON.
- All intermediate devices must have their terminations set OFF.
- If both connectors on the same DCM-I CDR-I PORT (either PORT A or PORT B) are being used, the DCM-I may be considered as an intermediate device, and its termination should be set to OFF\*.

The correct termination setting is indicated for each device in the three wiring examples illustrated on page 6. See Step 5 of “**Connecting and Mounting – CDR-I**” on page 11, or Step 3 of “**Connecting and Mounting – CDRIF**” on page 14 for details of how to set it.

\*Please refer to the **DCM-I Installation and User Guide**, Section 4 (**Appendix**), for details of how to set/unset the DCM-I’s CDR-I PORT network terminations.

## Cable length and DC power considerations

The DCM-I's internal PSU has sufficient capacity to power 8 CDRs (i.e., one per zone) provided cable runs are not excessive and good quality cable and connectors are used. If a system has more than 8 CDRs in total, one or more additional PSUs will certainly be required. The probability of correct operation is a function of cable length, cable and connector quality, the number of CDRs daisy-chained, and how many of them are at a great distance from the DCM-I.

The maximum recommended cable length of the CDR network for reliable data transmission is 1 km. This figure applies either to the total cable run between the "farthest" CDR and the DCM-I if a single daisy-chain of CDRs has been employed (as in (b) on page 6), or to the total run between the most remote CDRs if the DCM-I is in the "middle" of the chain (as in illustration (a) on page 6). Cable runs longer than this may work satisfactorily, but this cannot be guaranteed. Note that the 1 km figure is a maximum over which data may be reliably transmitted, not over which a set of CDRs may be reliably powered. In all systems, it is the power distribution which will limit maximum cable length, not the data.

If a CDR is found to operate unreliably, it should be powered independently from a local PSU. The Cloud CPM-PSU is suitable for this purpose, and should be connected to the EXT POWER socket at the rear of the CDR. In the case of the CDR-I, this is a coaxial socket, mounted vertically on the PCB to the right (viewed from the rear). See diag. on page 11. In the case of the CDR IF, the EXT POWER socket is a 2-pin 5 mm-pitch screw terminal type connector below the RJ45 connectors; a mating male connector is supplied with the unit. See diag. on page 13.

**Note:** Wiring convention of the external PSU is unimportant, as the CDR incorporates a bridge rectifier circuit which allows it to accommodate either polarity of connection.

Note that any further CDRs connected to the POWER OUT connector will be powered by the external PSU.

If a third-party external PSU is to be used, it should be rated at either 12 – 24V DC or 9 – 17V AC. The current consumption of a CDR is 50 mA at 12V.



## Wiring

Feed the installed CAT-5 cable(s) (or pre-made patch cable(s)) into the back box on which the CDR is to be mounted. If not using pre-made cables, crimp the RJ45 connector(s) as per the pinout diagram below:

PIN	USE	CAT-5 CORE
1	n/u	White + Orange
2	n/u	Orange
3	n/u	White + Green
4	DC +ve	Blue
5	0v	White + Blue
6	n/u	Green
7	Data H	White + Brown
8	Data L	Brown

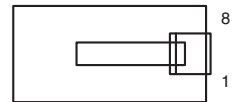
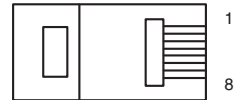

The connection at the DCM-I end is identical. Note that the CAT-5 interconnection provides DC power as well as data, but also see the following chapters concerning connecting and mounting the CDR-I and CDRIF.

## Connecting and mounting – CDR-I

The CDR-I is designed for use with single-gang UK, US or Australian electrical back boxes, using the mounting plate provided. It is also possible to mount it without a back box directly onto a wall.

The mounting plate has several sets of fixing holes to accommodate the different styles of box. UK single-gang boxes are square, but note that if fitting to a US or Australian box, it should be fitted with the long axis horizontal ('landscape' orientation), with the screw holes to left and right.

1. Detach the mounting plate from the rear of the CDR-I by removing the two countersunk M3 screws. Retain the screws.
2. **With back box:** bring the CAT-5 cable(s) into the back box and pass through the entry hole on the mounting plate. If a local external PSU is being used to power the CDR-I, the DC feed from this should be fed through as well.

**Without back box:** simply pass the cables through the mounting plate entry hole.

3. **With back box:** attach the mounting plate to the back box using the M3.5 screws provided and the appropriate holes in the mounting plate (according to back box type).

**Without back box:** fix the mounting plate directly to the wall, using screws (not supplied) of a length and type appropriate for the wall construction. Note that it is important that only countersunk-headed screws are used, as a raised screw head may foul the CDR-I's internal PCB.

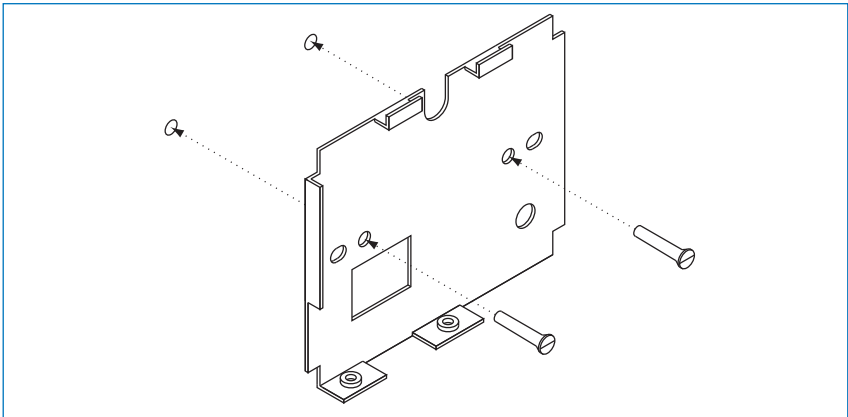

4. Plug the cables into the CDR-I sockets. The CAT-5 cable going to the mixer (possibly via other CDRs) should be connected to the **POWER IN** socket. If other CDRs are being installed further along the chain, the outgoing cable should be connected to the **POWER OUT** socket. Ensure the RJ45 connectors fully latch into place. If an external PSU is being used, plug it into the co-axial **EXT POWER** socket.

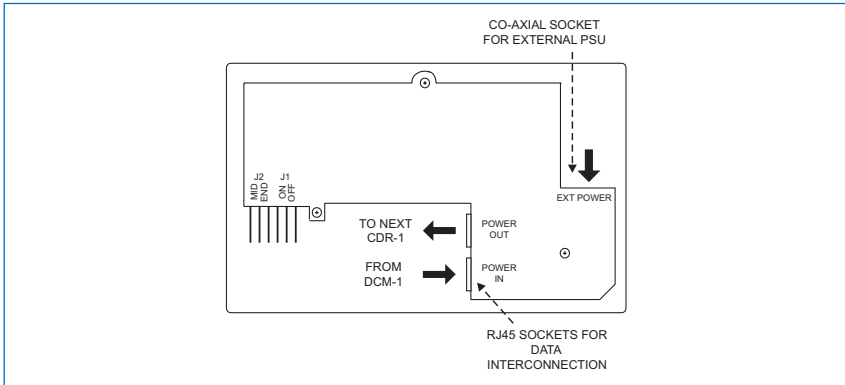

5. Check that jumper **J1** is in the **OFF** position. **J2** should be set according to the CDR-I's position in the CAT-5 "chain". If it is the final (or only) panel in the chain (i.e., nothing is plugged into the **POWER OUT** connector), set **J2** to **END**; in all other cases set it to **MID**. Carefully use tweezers or a pair of fine-nosed pliers for this operation.

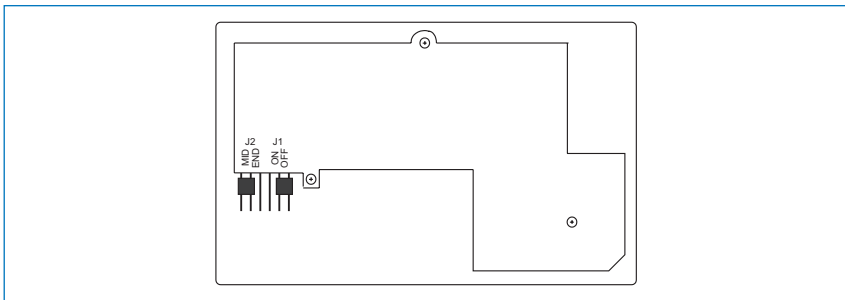

6. Angle the CDR-I so that the top is closer to the wall and push onto the mounting plate such that the two small lugs on the inside of the top of the housing mate with the corresponding flanges on the plate.
7. Push the bottom of the CDR-I towards the wall so that the two slots in the bottom of the housing line up with the tapped holes in the bottom of the plate.

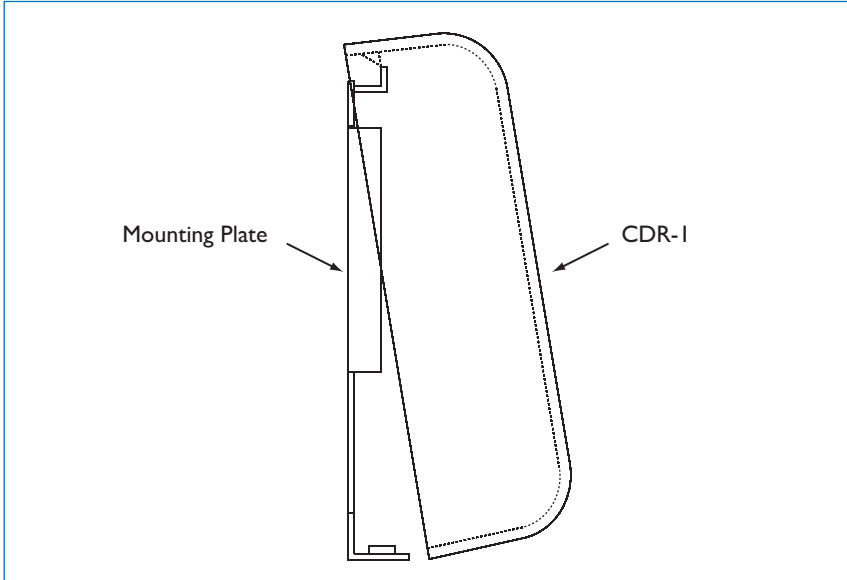

8. Screw the CDR-I to the mounting plate using the two countersunk M3 screws removed in step 1.

## Connecting and mounting – CDR IF

The CDRIF is intended for use with dual-gang UK size steel or PVC dry-lining back boxes with an internal depth of 47 mm. As the internal electronic assembly is fully screened, it can also be mounted without a back box directly into a suitable wall cavity. Refer to page 14 for CDRIF dimensions

In order for the display to be readily legible, only “landscape” orientation should be employed.

1. **With back box:** bring the CAT-5 cable(s) into the back box. If a local external PSU is being used to power the CDRIF, the feed from this should be fed through as well.

**Without back box:** simply feed the cables up through the hole in the wall.

2. Plug the cables into the CDRIF sockets. The CAT-5 cable going to the mixer (possibly via other CDRs) should be connected to the POWER IN socket. If other CDRs are being installed further along the chain, the outgoing cable should be connected to the POWER OUT socket. Ensure the RJ45 connectors fully latch into place. If an external PSU is being used, plug it into the 2-pin EXT POWER socket.

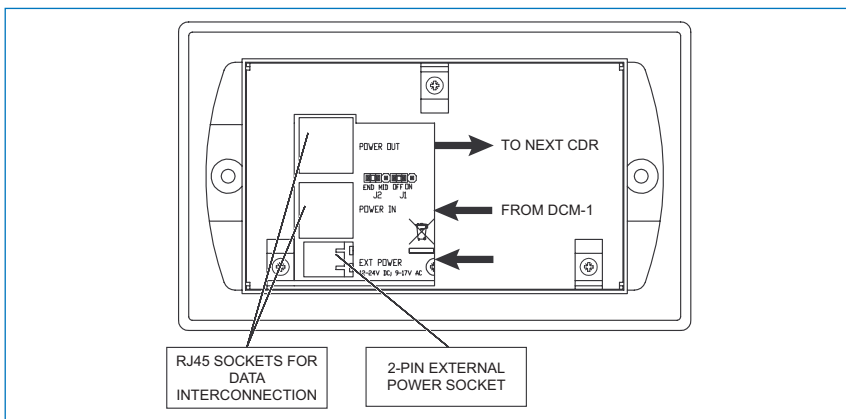

- Check that jumper J1 is in the OFF position. J2 should be set according to the CDRIF's position in the CAT-5 "chain". If it is the final (or only) panel in the chain (i.e., nothing is plugged into the POWER OUT connector), set J2 to END; in all other cases set it to MID. Carefully use tweezers or a pair of fine-nosed pliers for this operation.

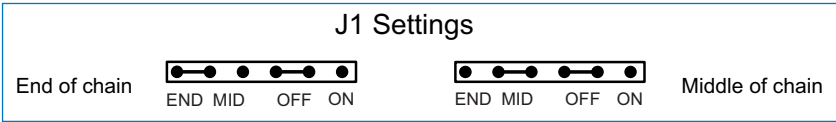

- With back box:** carefully position the rear metal screening box of the CDRIF into the back box, taking care that the CAT-5 cable(s) and PSU wiring (if used) are not under any strain. Insert the two M3.5 raised-head screws supplied through the fixing holes in the front plate and engage them in the threaded inserts or lugs of the back box. Tighten until the panel is neatly flush against the wall – do NOT over-tighten.

**Without back box:** carefully position the rear of the unit in the hole, and fix the front panel with screws of a type and length appropriate to the wall construction. No. 6 woodscrews are satisfactory provided that timber battens are available either side of the hole.

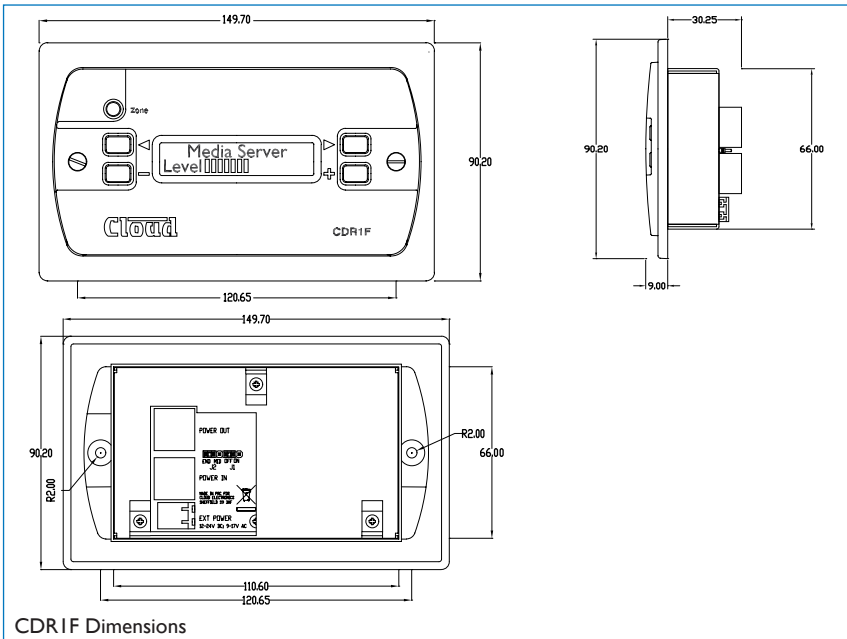

## Configuration

Each CDR must be assigned to a zone; this will normally be the zone in which it is physically located. As shipped from the factory, a CDR has no zone assigned, and when powered for the first time it will first display the backlight/contrast adjust screen, and then prompt for a zone assignment before continuing, as shown below:

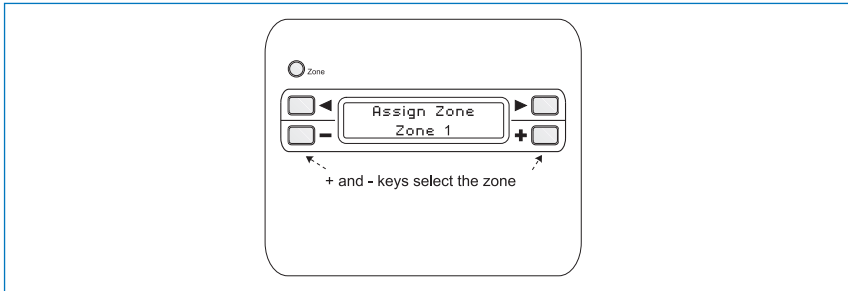

Use the + and – keys to scroll to the zone required, unless Zone 1 is correct. Press the ZONE button to accept the assignment (the display changes to the Set Key screen); after a few seconds, the CDR will enter normal User Mode, with the zone assignment confirmed.

If it is necessary to change the zone assignment at a later date for any reason, this can be done by putting the CDR into Installer Mode (see below).

### Installer mode

To put the CDR in Installer Mode:

- Remove the CDR from its back box or mounting position by removing the two M3 screws at the bottom of the housing in the case of the CDR-I, or by removing the two front fixing screws in the case of the CDR I F. Retain the screws.
- Remove power from the CDR, either by powering the system down or removing the POWER IN connector.
- Move jumper J1 from OFF to ON
- Reapply the power

Installer mode allows access to the following unit-specific settings:

- Backlight and contrast adjustment
- Inactivity time
- Zone assignment
- Set Engineer key

Each of the above settings can be accessed in turn by pressing the ZONE button. A full description of Installer Mode can be found in the **DCM-I Installation and User Guide**, Section 3 (**Configuration**).

To return the CDR to normal operation:

- Remove power from the CDR.
- Move jumper J1 from ON to OFF
- Reapply the power
- Refit the remote control to its mounting plate with the two M3 screws (CDR-I) or to its back box/mounting hole with the front panel fixing screws (CDRIF).

## User mode

The CDR's normal operating state is User Mode, which permits selection of music source, level adjustment, and Group enabling/disabling (if available).

User Mode is fully described in the **DCM-I Installation and User Guide**, Section 3 (**Configuration**).

## Engineer mode

The CDR can be used to adjust the EQ in a zone from within the zone itself by putting it in Engineer Mode. Engineer Mode must first be enabled from the DCM-I, and then a “password” key code entered on the CDR. The default key is listed below. The key can be changed in Installer Mode.

A full description of Engineer Mode, and how to enable it can be found in the **DCM-I Installation and User Guide**, Section 3 (**Configuration**).



## Default settings

J1 = OFF  
J2 = END  
KEY = "<<>>"

---

Should you have any questions concerning the installation and connection of the CDR-I/CDRIF please contact our Technical Support staff (details on rear cover).

## Notes





**Cloud Electronics Limited**

140 Staniforth Road, Sheffield. S9 3HF. England  
Tel: +44 (0)114 244 7051 Fax: +44 (0)114 242 5462  
email: [info@cloud.co.uk](mailto:info@cloud.co.uk) web: [www.cloud.co.uk](http://www.cloud.co.uk)

---