

MR16 ASSEMBLY KIT

- Kit for direct MR16 replacement
- Ideal for experimenting or developing
- Mains Dimmable, 1-10V and DALI+ dimming options
- Includes high efficiency nano-diffuser
- Different light engine options
- Part L compliant: > 60lm/W
- Unique CFD-optimised heat sink
- Includes graphite thermal interface



Product Overview

Serenity Lighting announces the DL Elite Mini MR16 Assembly Kit to allow engineers and lighting fixture designers to experiment, design and optimise an MR16 product for their own production. The Assembly Kit contains all of the essential components to build a high specification LED-based MR16 unit with a selection of LED drivers and LED light engines. The flexibility of the MR16 kit is that you can create a bespoke LED fixture by simply adding your own LED light engine, driver, thermal interface material or reflector, so you are in control of the final product specification.

The standard kit comes with everything you need (except the light engine and LED driver which are supplied as options) to create an IP65 rated MR16 downlight suitable for Zones 1, 2 and 3.

The MR16 Kit is easy to assemble and is made of only the highest quality components, such as the latest graphite material for the thermal interface and CFD-optimised heat sink, to ensure high performance and longevity of the product.

Once assembled, the DL Elite Mini MR16 product will be a superior replacement for Mr16, GU10 or incandescent downlights, suitable for residential and commercial new builds, refurbishments or retrofits. The DL Elite Mini is an energy efficient and zero maintenance light fitting, which is dimmable via approved mains dimmers, 1-10V & DALI+ controllers.

Tel : +44 (0)1922 457 712
E-mail : sales@serenitylighting.co.uk

www.serenitylighting.co.uk

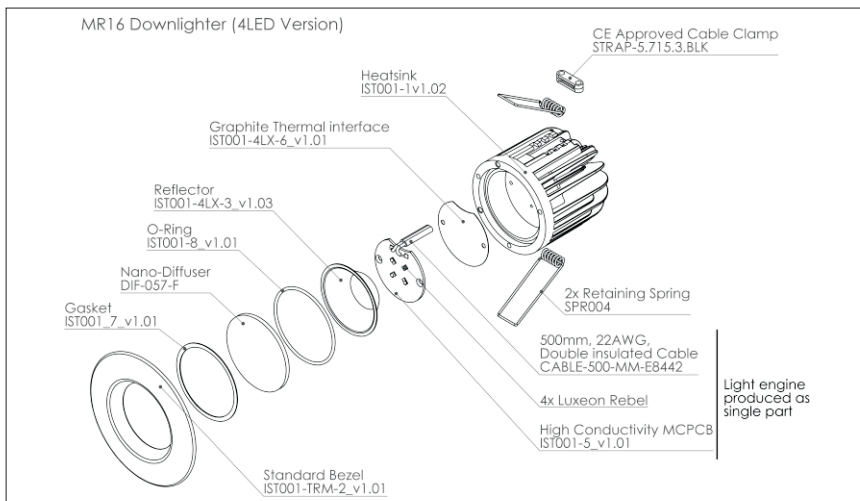

Product Options

Product Name	Part No.	Pack Qty	Height (mm)	Width (mm)	Depth (mm)	Weight(kg)
MR16 ASSEMBLY KIT	MR16-KIT001	1	100	180	140	0.5
MR16 4 LED LIGHT ENGINE 3000K	PCB47-04-LXM8PW30	1	8	8	100	0.1
MR16 4 LED LIGHT ENGINE 4000K	PCB47-04-LXW8PW40	1	8	8	100	0.1

Further light engine options available on request

Associated Drivers

Driver Name	Part No.	Typical Efficiency (%)
iDrive® MultiDim	IDM011152	86
iDrive® Solo CC (non-dimmable)	IDS2014200700	83
iDrive® Solo CC (dimmable)	IDM2011150700	83
iDrive® DALI+ / 1-10V	IDD2011150700	88

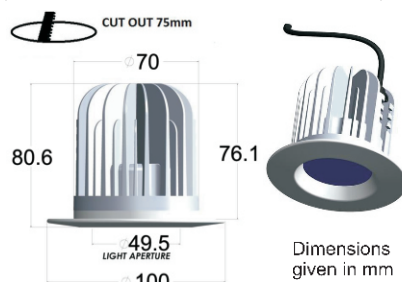

Serenity Lighting
Suite 5, Birch House
Birch Lane Business Park, Birch Lane
Aldridge
West Midlands
WS9 0NF
United Kingdom

