

Next Generation Intelligent LCD Panels

DPP-CTS2432 Specification
DPP-CTS2440 Specification
DPP-CxP3224-2 Series Specification
DPP-Cx4827 Series Specification
DPP-CT3224-2 Specification
DPP-Cx6448 Series Specification
DPP-Cx8048 Series Specification
DPP-Cx1060 Series Specification

Version 1.6

Document Date: August 8, 2011

Copyright © by demmel products 2008 - 2011

Unless otherwise noted, all materials contained in this document are copyrighted by demmel products and may not be used except as provided in these terms and conditions or in the copyright notice (documents and software) or other proprietary notice provided with the relevant materials.

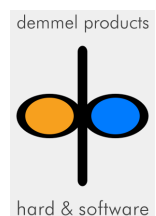

General Description

The iLCD modules are intelligent LCD panels which allow the user to carry out all graphic and font needs via an easy and comfortable way without having to deal with pixel addressing, low level functions or hardware details. Controlling the screen contents is done either via a serial port, I²C port, SPI port or via USB.

Features

Display Specific Data

Item	DPP-CTS2432	DPP-CTS2440
Screen Size	2.8 inch	3.0 inch
Display Resolution	240 x RGB x 320 dots	240 x RGB x 400 dots
Dot Pitch	0.06 (H) x 0.18 (V) mm	0.0545 (H) x 0.1635 (V) mm
Active Area	43.2 (H) x 57.6 (V) mm	39.24 (H) x 65.40 (V) mm
Display Mode	Normally white/Transmissive	
Pixel Arrangement	RGB-Strip	
Display Color	262 k (Display) / 64k (Controller)	262 k (Display) / 64k (Controller)
Backlight ¹⁾	White LED, typical lifetime 20.000 hours	
Brightness typ. ²⁾	300 cd/m ²	250 cd/m ²
Contrast ratio typ.	400	400
Viewing Direction	6 O'clock	3 O'clock
Touch Screen	4-wire resistive	4-wire resistive

Item	DPP-CxP3224-2	DPP-C4827	DPP-CT4827
Screen Size	3.5 inch	4.3 inch	
Display Resolution	320 x RGB x 240 dots	480 x RGB x 272 dots	
Dot Pitch	0.073 (H) x 0.219 (V) mm	0.066 (H) x 0.198 (V) mm	
Active Area	70.08 (H) x 52.56 (V) mm	95.04 (H) x 53.856 (V) mm	
Display Mode	Normally white/Transmissive		
Pixel Arrangement	RGB-Strip		
Display Color	16.7 M (Display) / 64k (Controller)	16.7 M (Display) / 64k (Controller)	
Backlight ¹⁾	White LED, typical lifetime 20.000 hours		
Brightness typ. ²⁾	300 cd/m ²	250 / 500 ³⁾ cd/m ²	250 / 400 ³⁾ cd/m ²
Contrast ratio typ.	400	250	
Viewing Direction	6 O'clock		
Touch Screen	4-wire resistive	No	4-wire resistive

Item	DPP-CT3224-2	DPP-C6448	DPP-CT6448
Screen Size	5.7 inch	5.7 inch	
Display Resolution	320 x RGB x 240 dots	640 x RGB x 480 dots	
Dot Pitch	0.12 (H) x 0.36 (V) mm	0.0588 (H) x 0.1764 (V) mm	
Active Area	115.2(H) x 86.4(V) mm	112.896(H) x 84.672(V) mm	
Display Mode	Normally white/Transmissive		
Pixel Arrangement	RGB-Strip		
Display Color	262 k (Display) / 64k (Controller)	262 k (Display) / 64k (Controller)	
Backlight ¹⁾	White LED, typical lifetime 20.000 hours		
Brightness typ. ²⁾	300 cd/m ²	350 cd/m ²	
Contrast ratio typ.	400	500	
Viewing Direction	6 O'clock		
Touch Screen	4-wire resistive	No	4-wire resistive

Item	DPP-C8048	DPP-CT8048	DPP-C1060	DPP-CT1060
Screen Size	7 inch		10.2 inch	
Display Resolution	800 x RGB x 480 dots		1024 x RGB x 600 dots	
Dot Pitch	0.0635 (H) x 0.1905 (V) mm		0.0722 (H) x 0.2192 (V) mm	
Active Area	152.4 (H) x 91.44 (V) mm		221.7984 (H) x 131.52 (V) mm	
Display Mode	Normally white/Transmissive			
Pixel Arrangement	RGB-Strip			
Display Color	262 k (Display) / 64k (Controller)		16.7 M (Display) / 64k (Controller)	
Backlight ¹⁾	White LED, typical lifetime 20.000 hours			
Brightness typ. ²⁾	350 cd/m ²		300 cd/m ²	
Contrast ratio typ.	400		500	
Viewing Direction	6 O'clock			
Touch Screen	No	4-wire resistive	No	5-wire resistive

Note:

1. Brightness decreased to be 50% of the initial value. Life time; mean time before failure at normal temperature(25°C) and normal humidity(60%)
2. Without touch screen
3. Board Revision V3 and newer

Electrical Specific Data

Item	DPP-CTS2432 / DPP-CTS2440
Connectivity	USB 2.0 / 1 x RS-232 3.3V / I ² C / SPI
I/O Ports	4 general purpose ports (12 bit ADC 0..Vcc or digital input or output), control for 2 relays outputs, keyboard with up to 128 keys, miscellaneous I/O ports
Real-Time Clock	Yes
Flash Memory	2 MByte for fonts, graphics, macros and text templates
iLCD controller	DPC3050 operating at 100 MHz

Item	DPP-CxP3224-2 / DPP-Cx4827 / DPP-CT3224-2 / DPP-Cx6448 / DPP-Cx8048 / DPP-Cx1060
Connectivity	USB 2.0 / 1 x RS-232 3.3V / I ² C / SPI
I/O Ports	4 general purpose ports (10 bit ADC 0..Vcc or digital input or output), control for 2 relays outputs, keyboard with up to 128 keys, miscellaneous I/O ports
Real-Time Clock	Yes
Flash Memory	32 MByte for fonts, graphics, macros and text templates
RAM	8 MByte RAM for frame buffer and for screen saving
iLCD controller	DPC3080 operating at 72 MHz

Mechanical Specification

Item	DPP-CTS2432	DPP-CTS2440	DPP-CT3224-2 / DPP-CT3224-2	DPP-C4827 / DPP-CT4827	Unit
Module Dimension (without mounting brackets)	50.0 x 69.2	45.0 x 77.0	76.9 x 63.9	105.5 x 67.2	mm
Module Dimension (incl. mounting brackets)	60.0 x 69.2	55.0 x 77.0	89.0 x 63.9	118.5 x 67.2	mm
Total Module Thickness	8.0	7.5	9.0 / 8.0	8.1 / 9.5	mm

Item	DPP-CT3224-2	DPP-C6448 / DPP-CT6448	DPP-C8048 / DPP-CT8048	DPP-C1060	Unit
Module Dimension (without mounting brackets)	126.0 x 101.55	126.5 x 100.0	165.0 x 104.0	235.0 x 145.80	mm
Module Dimension (incl. mounting brackets)	142.0 x 101.55	142.0 x 100.0	182.0 x 104.0	252.0 x 145.80	mm
Total Module Thickness	12.0	9.6 / 11.0	9.6 / 11.0	10.1	Mm

Item	DPP-CT1060				Unit
Module Dimension (without mounting brackets)	236.6 x 147.59				mm
Module Dimension (incl. mounting brackets)	252.0 x 147.59				mm
Total Module Thickness	11.5				mm

Maximum Ratings

Item	Symbol	Minimum	Maximum	Unit
Supply Voltage	V_{CC}	-0.3	5.5	V
Input Voltage	V_{IN}	-0.3	3.3	V
Operating Temperature ¹⁾	T_{OPR}	-20	70	°C
Storage Temperature	T_{STR}	-20	80	°C
Humidity ²⁾		10	90	%RH

Note:

1. Lifetime of backlight LEDs will be decreased for temperatures $\geq 50^{\circ}\text{C}$
2. Temp. $\leq 60^{\circ}\text{C}$, 90% RH MAX.
Temp. $\geq 60^{\circ}\text{C}$, absolute humidity shall be less than 90% RH at 60°C

Electrical Characteristics

Electrical characteristics for DPP-CTS2432 / DPP-CTS2440

Item	Symbol	Condition	Min.	Typ.	Max.	Unit
Supply Voltage	V_{CC}	-	3.2	5.0	5.25	V
Input Voltage H Level ¹⁾²⁾	V_{IH}	-	2.4	-	3.3	V
Input voltage L Level ¹⁾	V_{IL}	-	0.0	-	0.8	V
Output current ³⁾	I_{OUT}	-			3.5	mA

Note:

1. For digital inputs only
2. Digital inputs are 5-volt tolerant
3. For digital outputs

Electrical characteristics for DPP-CxP3224-2 / DPP-Cx4827 / DPP-CT3224-2 / DPP-Cx6448 /
DPP-Cx8048 / DPP-Cx1060

Item	Symbol	Condition	Min.	Typ.	Max.	Unit
Supply Voltage	V_{CC}	-	4.75	5.0	5.25	V
Input Voltage H Level ¹⁾²⁾	V_{IH}	-	2.4	-	3.3	V
Input voltage L Level ¹⁾	V_{IL}	-	0.0	-	0.8	V
Output current ³⁾	I_{OUT}	-			3.5	mA

Note:

1. For digital inputs only
2. Digital inputs are 5-volt tolerant
3. For digital outputs

Typical current consumption in mA @ $V_{CC} = 5V$, no I/O ports active

Item	DPP- CTS2432	DPP- CTS2440	DPP- CxP3224-2	DPP- Cx4827	DPP- CT3224-2	DPP- Cx6448
Current consumption with display switched off	70	76	75	75/82 ³⁾	75	75
Current consumption display on, backlight off ¹⁾	71	76	87	150/110 ³⁾	102	120
Current consumption with display+backlight ¹⁾²⁾	185	260	198	255	460	460

Item	DPP- Cx8048	DPP- Cx1060				
Current consumption with display switched off	83	86				
Current consumption display on, backlight off ¹⁾	329	369				
Current consumption with display+backlight ¹⁾²⁾	780	1080				

Note:

1. All pixel set to white color
2. Backlight intensity 100%
3. Board Revision V3 and newer

Module Function Description

Important Information about USB and Serial Ports

The above mentioned modules contain a USB and two 3V3 serial ports. Serial port 1 and USB port is available on the FFC connector by default. The USB port is implemented as an HID device thus requiring no extra drivers, as all major operating systems use this system-driver for supporting mice and keyboards.

Setting different baud rates than 115200 Baud can be done via the "Set Baud Rate" command (see the extra document "iLCD Commands") for the serial port currently in use until the next power up or reboot of the iLCD panel. The baud rate has to be set in the "Preferences" section of your iLCD setup accordingly. Changing the communication speed of the iLCD controller's serial port 1 permanently can be done in the "Setup" section via "Edit->Setup Data..." on the "Hardware" tab for "Baud Rate 1". After downloading this new setup data via the USB port to the iLCD panel, the baud rate of the setup software is changed automatically according to the new setting, a message box appears.

The baud rate of the serial port 0 can be set in the same way. In case of any misconfiguration possibly further disabling the communication via the serial port, the evaluation board's "Erase" jumper can be set

during power up (pulling the RX1 port low) to completely erase the flash user data. The default value of 115200 Baud is reset on both serial ports and the user data has to be re-written via the setup software.

The serial port 0 is -not connected to the FFC connector of the board by default. If you need to have this option installed, please contact demmel products for instructions about how to adapt your hardware. If installed, serial port 0 uses the D+ and D- pins of the "Control" FFC connector and the USB port is not available anymore. The serial port 1 is always connected to the FFC connector and can be disabled via the setup software.

General Information about Port Pins

Most port pins can be used as outputs (push/pull or pull down only outputs), as keyboard column outputs or as digital inputs besides of their primary function. The assignment of these port pins must be done once via the setup software under "Edit->Setup Data..." on the hardware tab by pressing the "Pin Assignments..." button. The names of the pins described below refer to the primary function only, the notes show the alternative functionality.

As the DPC3050 (for DPP-CTS2432 and DPP-CTS2440 models only) / DPC3080 iLCD controller is working with a power supply of 3/3.3V (a voltage-regulator for this voltage is on-board allowing the board to work with single 5V supply), push/pull outputs have a voltage swing of 0V ... 3/3.3V. Pull down outputs and digital inputs are 5V tolerant (with some exceptions, see the comments below) allowing to work with 5V systems as well.

Pin Descriptions

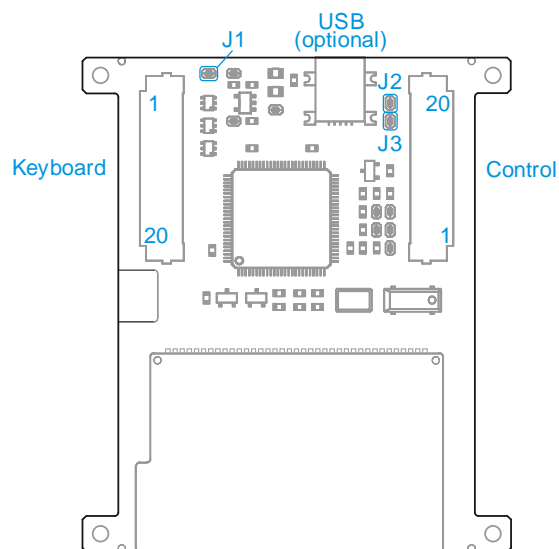

DPP-CTS2432 connections (view from P.C.B. side)

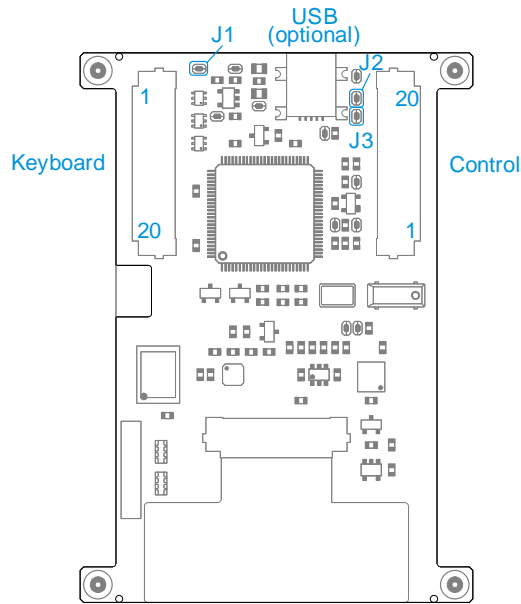

DPP-CTS2440 connections (view from P.C.B. side)

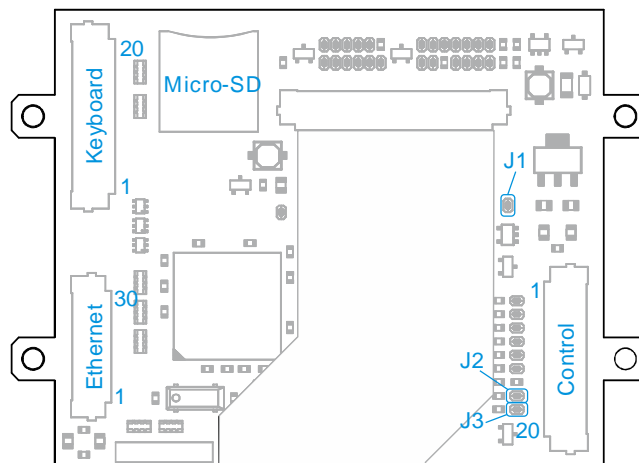

DPP-CxP3224-2 connections (view from P.C.B. side)

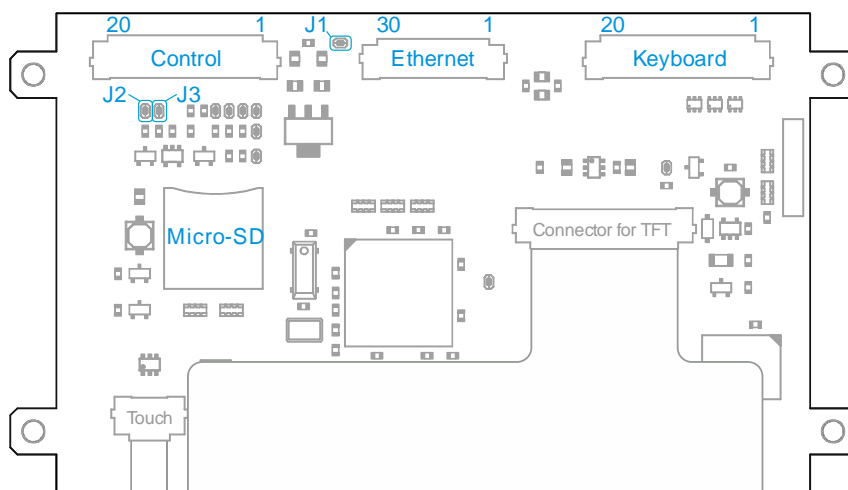

DPP-Cx4827 (board version 1 and 2) connections (view from P.C.B. side)

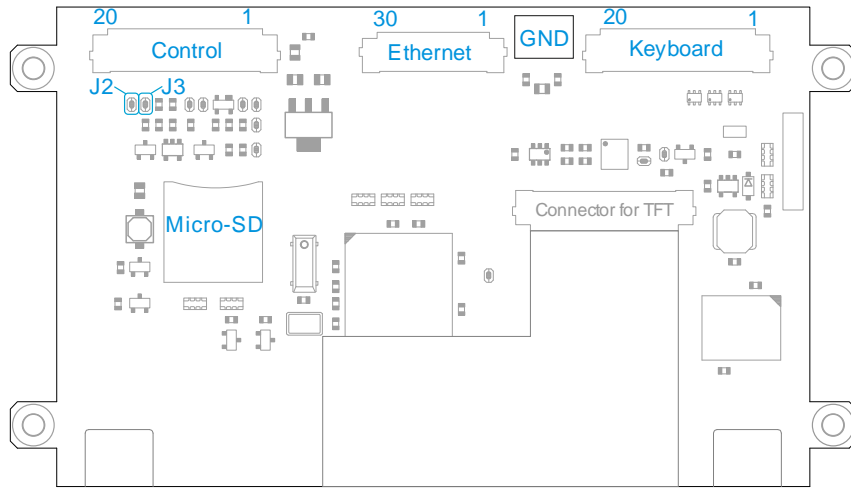

DPP-Cx4827 (board version 3) connections (view from P.C.B. side)

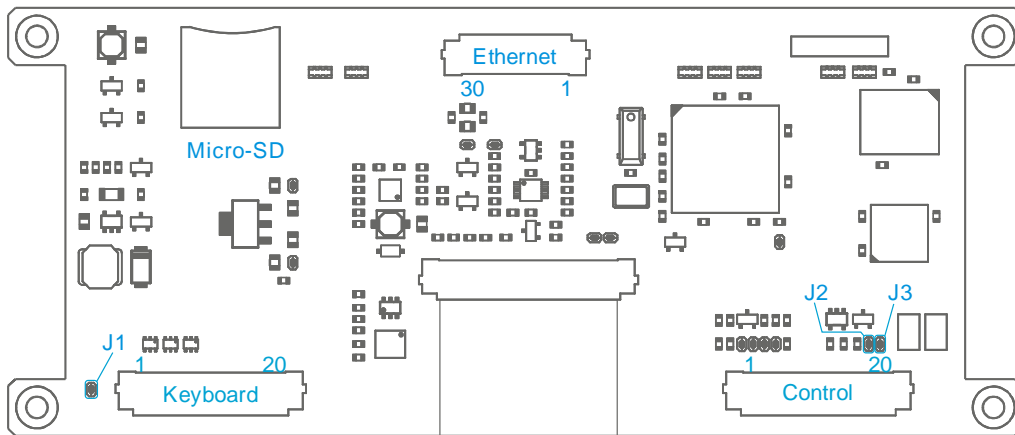

DPP-CT3224-2 connections (view from P.C.B. side)

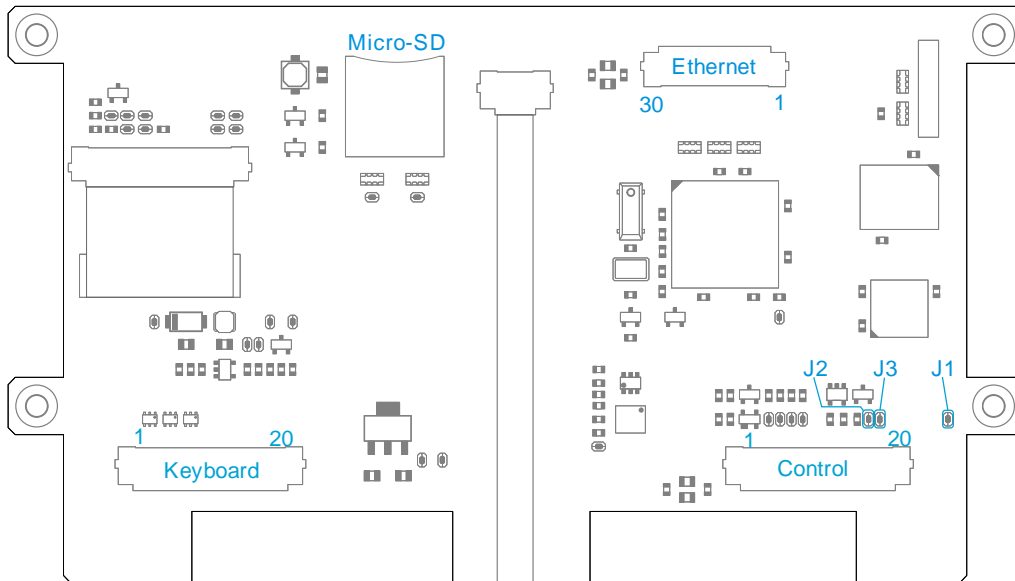

DPP-Cx6448 (board version 1) connections (view from P.C.B. side)

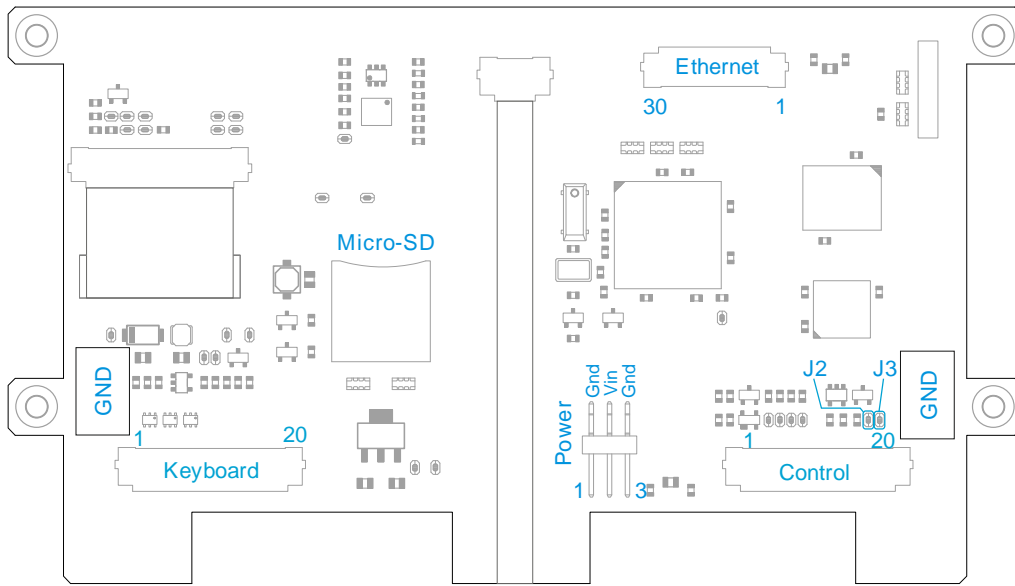

DPP-Cx6448 (board version 2) connections (view from P.C.B. side)

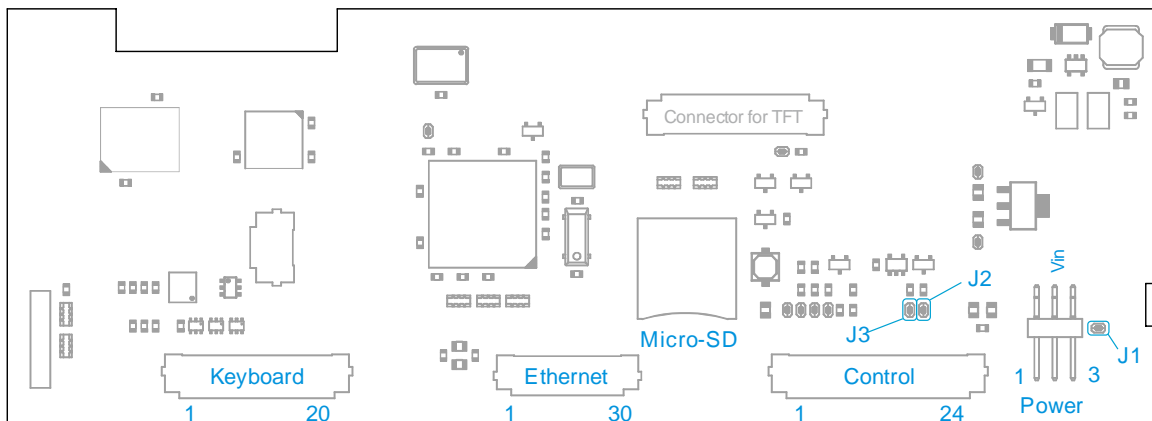

DPP-Cx8048 (board version 5 and older) connections (view from P.C.B. side)

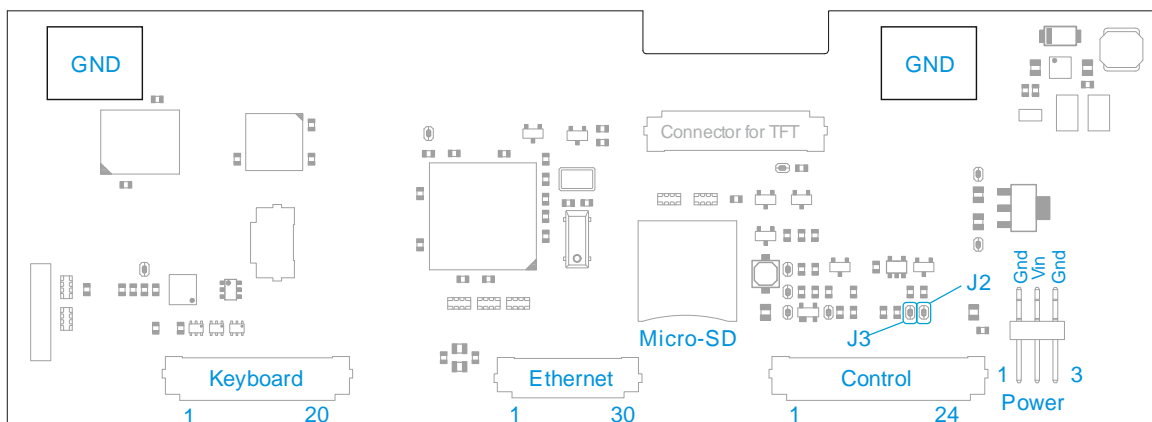

DPP-Cx8048 (board version 6) connections (view from P.C.B. side)

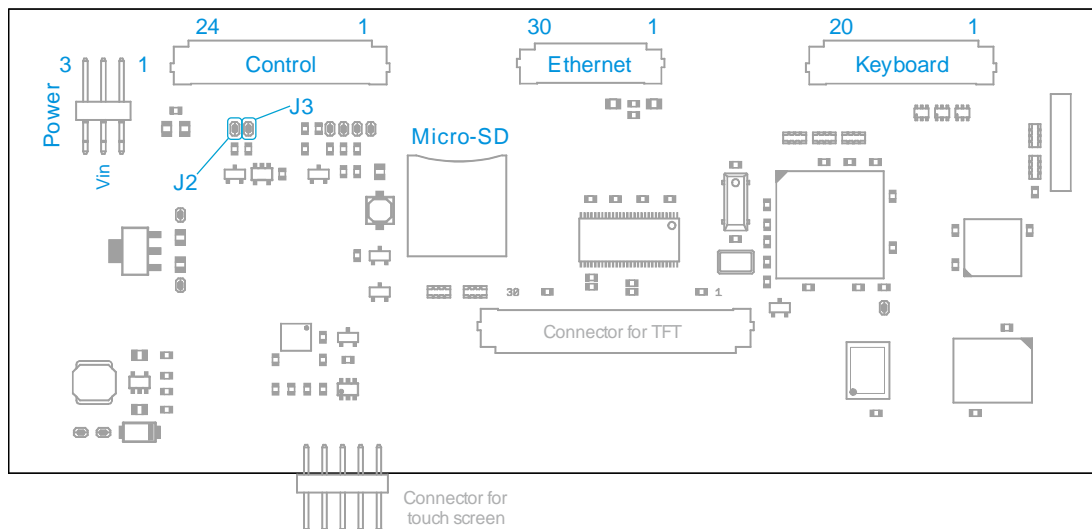

DPP-Cx1060 connections (view from P.C.B. side)

Power Connector (Power)

The DPP-Cx8048 and the DPP-Cx1060 iLCD panels can either be supplied via the Power Connector or via the Control Port. When the panel is supplied via the Control Port, all three GND must be connected and all three VCC pins must be connected to not exceed the maximum allowed current per pin of the FFC/FPC connector. All other iLCD panels do have a lower operating current thus requiring no extra Power Connector and needing a 20-pin Control Port connector only.

Pin #	Pin Name	Direction	Primary Function Description
1	GND ¹⁾	-	Ground pin
2	VCC ²⁾	-	5V (optionally 3.3V) power supply
3	GND ¹⁾	-	Ground pin

Note:

1. The GND pin is connected to pin 4, 23 and 24 of the Control Port FFC/FPC connector.
2. The VCC pin is connected to pin 1, 21 and 22 of the Control Port FFC/FPC connector.

WARNING! Reversed power supply connections (Vcc and Gnd) made to the iLCD module or invalid power supply voltage greater than 5.5V (3.3/3.6V when using a 3/3.3V variant) will cause module damage.

Control Port (Control)

Connection to the control port is made via a 20-pin or a 24-pin (DPP-Cx8048 and DPP-Cx1060 models only) FFC/FPC cable with 1.0 mm pitch. The FFC/FPC connector on the board is a top-contact model. Please note, that smaller color iLCD panels do have a 20-pin FFC/FPC connector only. The additional 4 pins of the 24-pin FFC/FPC connector for the larger models are used due to the higher operating current only and contain VCC and GND pins only.

If one wants to connect a evaluation kit of the smaller color iLCD panels to the 24-pin FFC/FPC connector, this can be done by using a 20-pin FFC/FPC cable, if the cable is orientated at pin 1 (pin 21 ~ 24 kept free then) and a 5V power supply is applied to the Power port then. The Vsel jumper of the evaluation board must be removed in this case!

Please note that the pin names of the serial port connections are seen from the driving PC / application side, that means a pin with name TX is in fact the output of the PC and an input of the iLCD panel. "Direction" is valid only when the primary function is enabled.

Pin #	Pin Name	Direction	Primary Function Description
1	VCC ¹⁰⁾	-	5V (optionally 3/3.3V) power supply
2 ¹⁾	USB-	In/Out	USB-, can be directly connected to pin 2 of a USB-Jack B
3 ²⁾	USB+	In/Out	USB+, can be directly connected to pin 3 of a USB-Jack B
4	GND	-	Ground pin
5	TX1 ³⁾	In	Serial port 1, transmit line from PC, receive input of iLCD controller. Can be used for RS-422/RS-485 in conjunction with ALERT pin
6	RX1 ³⁾⁸⁾	Out	Serial port 1, receive line to PC, transmit output of iLCD controller. Can be used for RS-422/RS-485 in conjunction with ALERT pin
7	CTS	Out	Output to avoid input buffer overflow, connect to RS232 driver's CTS of the PC. Common for both serial ports.
8	SDA ⁴⁾⁷⁾	In/Out	I ² C data pin. Note, that there is no pull up resistor on the iLCD panel, so an external resistor may be necessary depending on the I ² C bus structure.
9	SCL ⁴⁾⁷⁾	In/Out	I ² C clock pin. Note, that there is no pull up resistor on the iLCD panel, so an external resistor may be necessary depending on the I ² C bus structure.
10	ALERT ³⁾	Out	Output pin to indicate I ² C data availability (= low) to the I ² C master. When using the RS422/RS485 mode on the second serial port, pin goes low during data transmit.
11	SCK ³⁾	In	Clock for SPI
12	MISO ³⁾	Out	Serial output line for SPI
13	MOSI ³⁾	In	Serial input line for SPI
14	SSEL ³⁾⁶⁾	In/Out	Must be tied to GND when using SPI
15	RELO	Out	Relay output 0 / PWM0 output
16	REL1	Out	Relay output 1 / PWM1 output
17	GPO ⁵⁾	In/Out	General purpose I/O pin 0. Use serial resistor when driving a LED.
18	GP1 ⁵⁾	In/Out	General purpose I/O pin 1. Use serial resistor when driving a LED.
19	I/O5 ³⁾⁹⁾ RESET	In/Out In/Out	Digital I/O pin /RESET – Pulling this pin low resets the iLCD module
20	Vbatt	-	Backup input voltage for real-time clock, should be between 2.5V and 3.3V
21	VCC ¹⁰⁾	-	5V (optionally 3.3V) power supply
22	VCC ¹⁰⁾	-	5V (optionally 3.3V) power supply
23	GND ¹¹⁾	-	Ground pin
24	GND ¹¹⁾	-	Ground pin

Note:

1. Alternatively TX0, see "Important Information about USB and Serial Port"
2. Alternatively RX0, see "Important Information about USB and Serial Port"
3. This pin can be used as a digital input, a push/pull or pull down output or a keyboard column output when the primary function is not enabled.
4. This pin can be used as a digital input, a pull down output or keyboard column output when the primary function is not enabled.
5. This pin can be used as a digital input, an analog input, a push/pull or pull down output or a keyboard column output. The voltage on this pin is not allowed to exceed 3/3.3V, even if it is used as a digital input or a pull-down output.
6. When using SPI, this pin must be used as SSEL for selecting the SPI via attaching a low signal.
7. When using the I²C port, this pin must be terminated with a resistor (usually 3k3) to 3/3.3V or 5V when the iLCD panel is the last device on the I²C bus. Please note, that the evaluation board has this pull-up resistor populated on the board.
8. When pulling low this pin via a 1k resistor during power-up, the flash memory's user data is erased.
9. The functionality of this pin depends on the setting of Jumper J2 and J3. When configured as /RESET pin, the board's internal power up reset signal can be seen on this pin as well.
10. Connect all VCC pins together in case you supply the iLCD panel via the FFC/FPC connector. VCC is connected to Pin 2 of the Power Connector as well. This pin is available on DPP-Cx8048 and DPP-Cx1060 only.

11. Connect all GND pins together in case you supply the iLCD panel via the FFC/FPC connector. GND is connected to Pin 1 and 3 of the Power Connector as well. This pin is available on DPP-Cx8048 and DPP-Cx1060 only.

WARNING! Reversed power supply connections (Vcc and Gnd) made to the iLCD module or invalid power supply voltage greater than 5.5V (3.3/3.6V when using a 3/3.3V variant) will cause module damage.

Keyboard Port (Keyboard)

Connection to the keyboard port is made via a 20-pin FFC/FPC cable with 1.0 mm pitch. The FFC/FPC connector on the board is a top-contact model.

Pin #	Pin Name	Direction	Primary Function Description
1	KBR0	In	Keyboard row 0
2	KBR1	In	Keyboard row 1
3	KBR2	In	Keyboard row 2
4	KBR3	In	Keyboard row 3
5	KBR4	In	Keyboard row 4
6	KBR5	In	Keyboard row 5
7	KBR6	In	Keyboard row 6
8	KBR7	In	Keyboard row 7
9	KBC0 ¹⁾	Out	Keyboard column 0, optionally I/O pin
10	KBC1 ¹⁾	Out	Keyboard column 1, optionally I/O pin
11	KBC2 ¹⁾	Out	Keyboard column 2, optionally I/O pin
12	KBC3 ¹⁾	Out	Keyboard column 3, optionally I/O pin
13	KBC4 ¹⁾	Out	Keyboard column 4, optionally I/O pin
14	KBC5 ¹⁾	Out	Keyboard column 5, optionally I/O pin
15	KBC6 ¹⁾	Out	Keyboard column 6, optionally I/O pin
16	KBC7 ¹⁾	Out	Keyboard column 7, optionally I/O pin
17	KBC8 ¹⁾	Out	Keyboard column 8, optionally I/O pin
18	GP2 ²⁾	In/Out	General purpose I/O pin 0. Use serial resistor when driving a LED.
19	GP3 ²⁾	In/Out	General purpose I/O pin 1. Use serial resistor when driving a LED.
20	I/O6 ¹⁾	In/Out	Digital I/O pin

Note:

1. This pin can be used as a digital input, a push/pull or pull down output or a keyboard column output when the primary function is not enabled.
2. This pin can be used as a digital input, an analog input, a push/pull or pull down output or a keyboard column output. The voltage on this pin is not allowed to exceed 3.3V, even if it is used as a digital input or a pull-down output.

MicroSD Connector (MicroSD)

To insert a MicroSD card, slide the connector in the direction of the OPEN-arrow engraved in the metal plate and lift it. Insert the card with the contact area facing down, then fold the connector back in and push carefully in the direction of the LOCK-arrow until it makes a click sound.

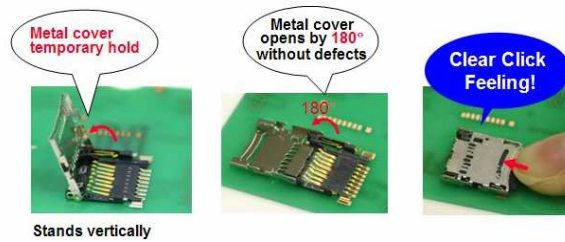

Please note that the DPP-CTS2432 and DPP-CTS2440 do not have a MicroSD card holder on board.

Jumper J1 (J1)

If jumper J1 is set (= soldered) the frame ground of the display is connected to GND, otherwise the frame ground is not connected.

iLCD panels not having the jumper J1 have the frame ground connected to GND.

Jumper J2 and J3 (J2 and J3)

If jumper J2 is set (= soldered) and jumper J3 is open, pin 19 of the control port is connected to I/O5.
If jumper J2 is open and jumper J3 is set (= soldered), pin 19 of the control port is connected to RESET.

Please note, that the default configuration has jumper J2 set and jumper J3 open.

Contrast and Gamma Value Setting

Please be informed that most of the panels described in this document do not need to set the contrast and the gamma values, as these values are set to the optimum values by the TFT panel producer. So setting the contrast and the gamma values via software on this new model do not have any effect, the iLCD setup software does not even offer to modify these values. Your application may issue the "Get Fixed LCD Contrast/Gamma" command to know if your iLCD panel needs to have set the contrast and gamma values.

Please see the extra document "iLCD Commands" describing the common command set available for all iLCD modules.

Evaluation Board

To make it easier to use and program the iLCD panels, a universal evaluation board has been designed. The iLCD panel is connected to the evaluation board via two FFC cables (2 x 24-pin or 1 x 20-pin and 1 x 24 pin) and contains the following parts:

- RS-232 Sub-D 9-pin connector + RS-232 driver IC
- USB Jack (type B)
- Power supply connector
- Speaker
- Terminal pins for relays, keyboard, ports and LEDs + interface electronic

Connectors and Jumpers

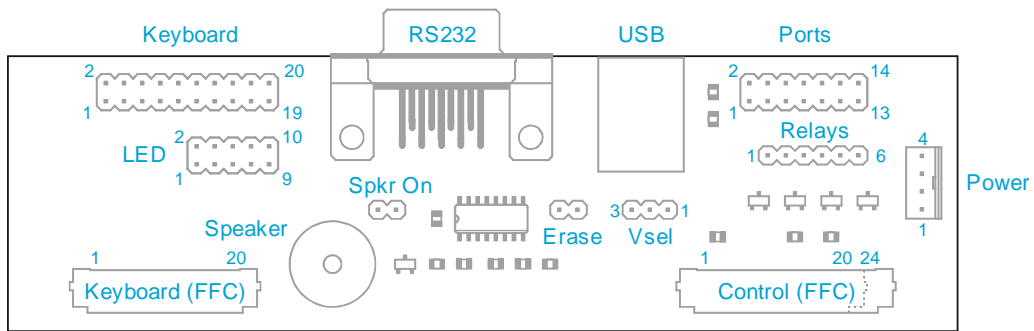

Universal evaluation board connector and jumper locations

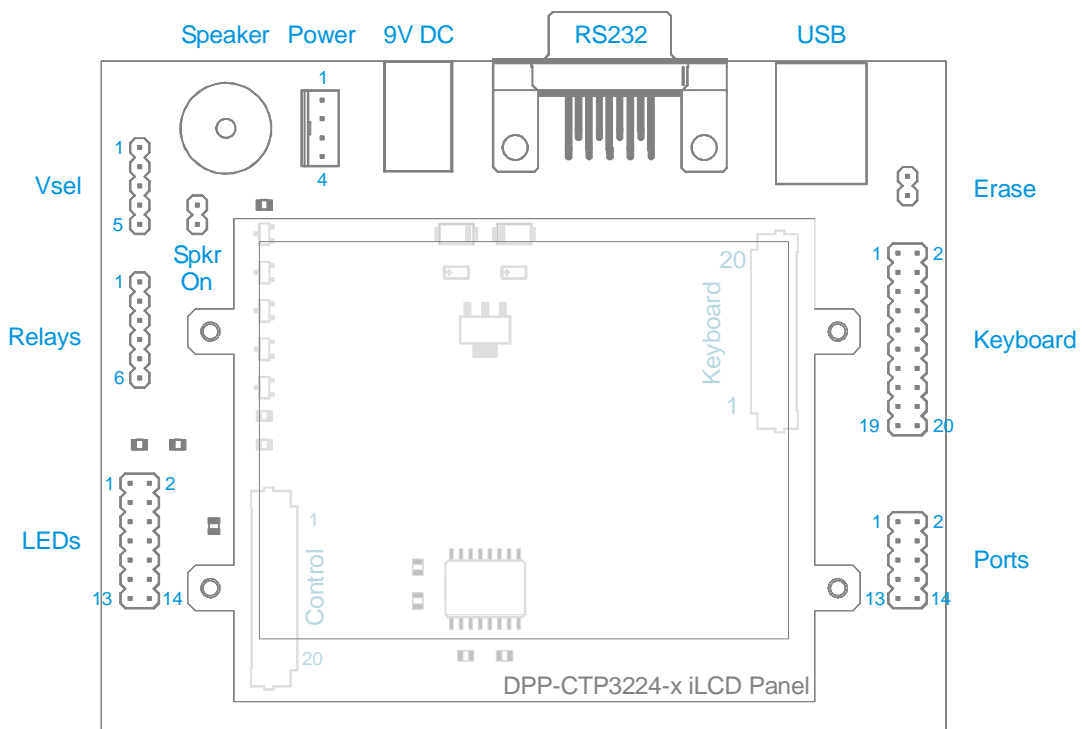

DPP-CTP3224-2 evaluation board connector and jumper locations

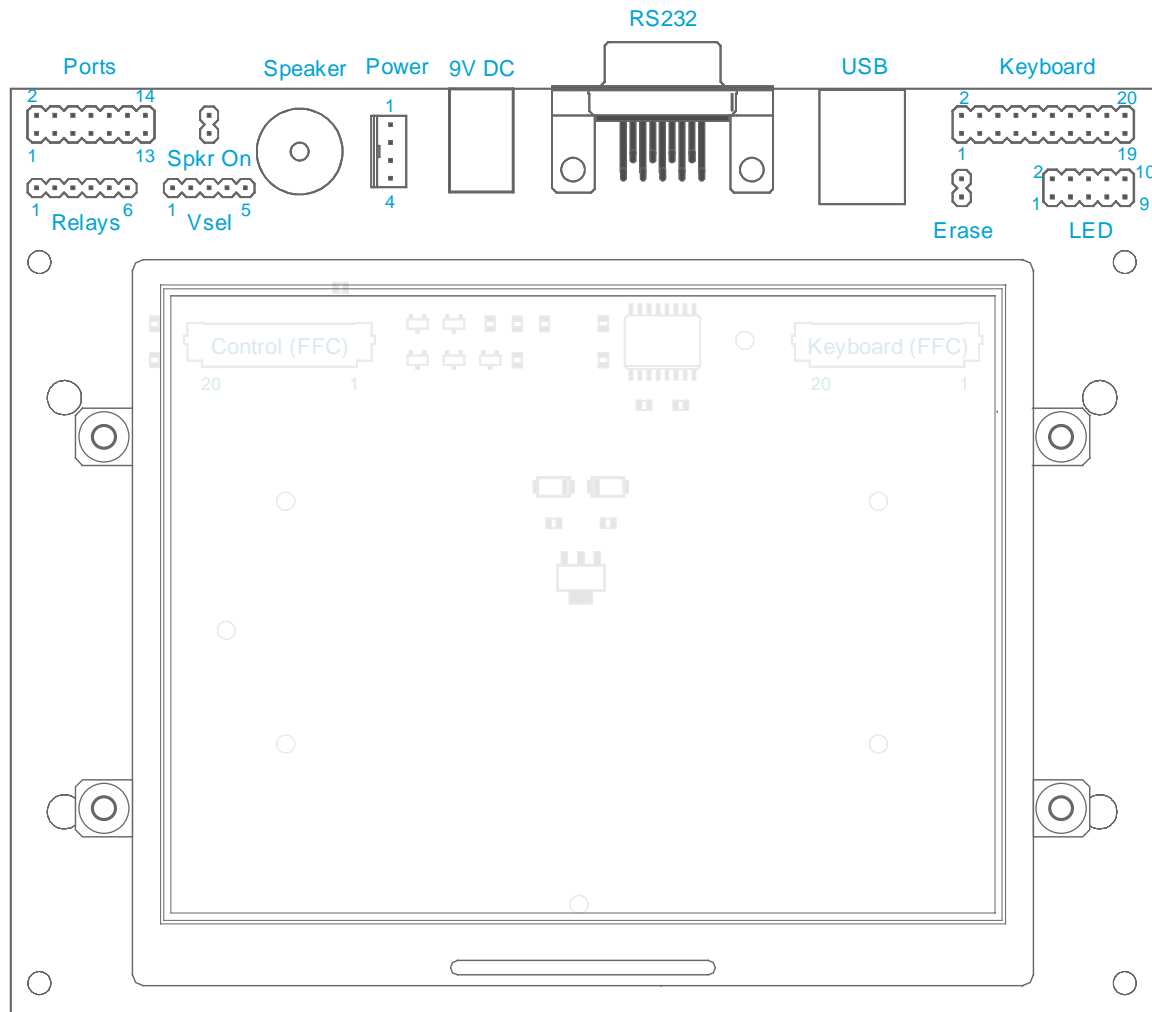

DPP-CT3224-2 / DPP-Cx6448 evaluation board connector and jumper locations

Control Connector to iLCD (Control (FFC))

This 20-pin or 24-pin (when intended to be used for DPP-Cx8048 or DPP-Cx1060) connector must be connected to the iLCD panel with the corresponding FFC connector. Please note, that the 20/24-pin FFC cable enclosed with the evaluation kit must be inserted with the contact surface upwards as the FFC connector is a top-contact model. The same is true for the FFC connector on the iLCD panel itself. As the board is intended to be used with the parts showing upwards when it is connected with the iLCD panel (display surface showing upwards as well), the FFC cable has the contact surface on the opposite sides on the two ends to accomplish a correct connection between evaluation board and iLCD panel.

Keyboard Connector to iLCD (Keyboard (FFC))

This 20-pin connector can be connected to the iLCD panel with the corresponding FFC connector. Please see the chapter above for learning how to insert the FFC cable.

Power Supply Connector (Power)

This connector applies the 5V power supply to the iLCD module if there is no USB port connected to the module. The connector used for this connection is the same as the power supply connector for a 3 ½" floppy disk drive, and has the same pinning.

Please note, that all iLCD panels mentioned in this document are available in a 3/3.3V variant optionally as well. If you connect an iLCD panel with 3/3.3V supply to the evaluation board, you **must** use 3/3.3V instead of the 5V supply, otherwise the iLCD panel would be damaged! Supplying the board plus the iLCD panel via USB port is not possible in this case!

The evaluation board itself can be operated with 3V up to 5V without having to change any settings.

Pin	Description
1	Not connected
2	Ground
3	Ground
4	V _{CC} (+5V / +3/3.3V)

AC/DC Power Adapter Connector (9V DC)

This connector can be used as an alternative to the Power Supply Connector when the iLCD module is not powered via the USB port. An unregulated power supply with 9V to 12V DC can be connected to the jack, the middle contact must be connected to the positive voltage. This input is safe against reverse polarity.

Power Supply Configuration Connector (Vsel)

Only one jumper is allowed to be set to select the power source for the iLCD module as follows:

Jumper Location		Description
Pin	Pin	
1	2	Enables the power supply connector's pin 4 (V _{CC})
2	3	Enables supplying the iLCD module via the USB port
3	4	Enables supplying the iLCD module via the USB port
4	5	Enables the power supply connector's pin 1 (V _{UNREG}) and/or the power jack

Please note, that the DPP-Cx8048 and DPP-Cx1060 iLCD panels can not be supplied via the USB port, as the USB port allows to draw a maximum of 500 mA only, which is exceeded by the DPP-Cx8048 and DPP-Cx1060 iLCD panels. **Trying to draw more than 500 mA from a USB port can damage your PC under worst circumstances!**

Serial Port Connector (RS232)

This 9-pin Sub-D female connector allows the driving application or PC to send and receive data from and to the iLCD module via standard RS232 signals. The pinning matches the standard layout of a PC's serial port.

The pins are connected with the iLCD's serial port 1, please see the note "Important Information about USB and Serial Port"

Pin On Sub-D	Direction	Description
1	-	Not connected
6	-	Not connected
2	Out	RX - data sent from the iLCD module to the controlling application / PC
7	In	RTS – not in use, but connected to the iLCD's RS232 driver
3	In	TX – data sent from the controlling application / PC to the iLCD module
8 ¹⁾	Out	CTS – iLCD's output for hardware flow control
4	-	Not connected
9	-	Not connected
5	-	Signal ground

Note:

1. See iLCD's command description about why you should connect this pin and when it is not necessary to use hardware flow control.

General Port Connector (Ports)

This connector enables you to connect the I²C port and some other signals described below. "Direction" is valid only when the primary function is enabled.

Pin #	Pin Name	Direction	Primary Function Description
1	VCC	-	3/3.3/5V power supply
2	SDA ⁴⁾	In/Out	I ² C data pin. Note, that there is no pull-up resistor on the iLCD panel itself, but the evaluation board contains a 3k3 pull-up resistor.
3	RX ¹⁾	Out	Serial port 0, receive line to PC, transmit output of iLCD controller.
4	SCL ⁴⁾	In/Out	I ² C clock pin. Note, that there is no pull-up resistor on the iLCD panel itself, but the evaluation board contains a 3k3 pull-up resistor.
5	TX ¹⁾	In	Serial port 0, transmit line from PC, receive input of iLCD controller
6	ALERT ³⁾	Out	Output pin to indicate I ² C data availability (= low) to the I ² C master. When using the RS422/RS485 mode on the second serial port, pin goes low during data transmit.
7	CTS ²⁾	Out	Output to avoid input buffer overflow, connect to CTS of the PC. Common for both serial ports.
8	SSEL ³⁾⁵⁾	In/Out	Must be tied to GND when using SPI
9	I/O5 ³⁾⁶⁾ RESET	In/Out In/Out	Digital I/O pin /RESET – Pulling this pin low resets the iLCD module
10	SCK ³⁾	In	Clock for SPI
11	GND	-	Ground pin
12	MISO ³⁾	Out	Serial output line for SPI
13	Vbatt	-	Backup input voltage for real-time clock, should be between 2.5V and 3.3V
14	MOSI ³⁾	In	Serial input line for SPI

Note:

1. This pin should not be connected when the USB+ and USB- are connected to these pins.
2. The digital CTS output connected to this pin is connected to the CTS port driver of primary RS232 port internally. This means that the iLCD's hardware flow control pin CTS is common for both RS232 ports.
3. This pin can be used as a digital input, a push/pull or pull down output or a keyboard column output when the primary function is not enabled.
4. This pin can be used as a digital input, a pull down output or keyboard column output when the primary function is not enabled.
5. When using SPI, this pin must be used as SSEL for selecting the SPI via attaching a low signal.
6. The functionality of this pin depends on the setting of Jumper J2 and J3 on the iLCD panel. If configured as /RESET pin, the board's internal power up reset signal can be seen on this pin as well.

USB Connector (USB)

This connector enables you to connect iLCD's USB port to a USB port on a PC via a standard USB cable.

Pin	Direction	Description
1	-	Vcc +5V
2	In/Out	USB-
3	In/Out	USB+
4	-	Ground

General Purpose I/O Connector (LEDs)

Depending on the settings in the iLCD's setup software the I/O ports can be a digital input, a push/pull or a pull-down output or an ADC input.

Pin	Name	Direction	Description
1	VCC	-	5V (optionally 3/3.3V) power supply
2	I/O5 ¹⁾ ³⁾ RESET	In/Out	Digital I/O pin
		In/Out	/RESET – Pulling this pin low resets the iLCD module
3	I/O6 ¹⁾	In/Out	Digital I/O pin
4	GP0 ²⁾	In/Out	General purpose I/O pin 0. Use serial resistor when driving a LED.
5	N/C	-	Not connected
6	GP1 ²⁾	In/Out	General purpose I/O pin 1. Use serial resistor when driving a LED.
7	N/C	-	Not connected
8	GP2 ²⁾	In/Out	General purpose I/O pin 0. Use serial resistor when driving a LED.
9	N/C	-	Not connected
10	GP3 ²⁾	In/Out	General purpose I/O pin 1. Use serial resistor when driving a LED.

Note:

1. This pin can be used as a digital input, a push/pull or pull down output or a keyboard column output.
2. This pin can be used as a digital input, an analog input, a push/pull or pull down output or a keyboard column output. The voltage on this pin is not allowed to exceed 3/3.3V, even if it is used as a digital input or a pull-down output.
3. The functionality of this pin depends on the setting of Jumper J2 and J3 on the iLCD panel. If configured as /RESET pin, the board's internal power up reset signal can be seen on this pin as well.

Keyboard Connector (Keyboard)

Pin	Name	Direction	Description
1	KBR0	In	Keyboard row 0
2	KBR1	In	Keyboard row 1
3	KBR2	In	Keyboard row 2
4	KBR3	In	Keyboard row 3
5	KBR4	In	Keyboard row 4
6	KBR5	In	Keyboard row 5
7	KBR6	In	Keyboard row 6
8	KBR7	In	Keyboard row 7
9	KBC0 ¹⁾	Out	Keyboard column 0, optionally I/O pin
10	KBC1 ¹⁾	Out	Keyboard column 1, optionally I/O pin
11	KBC2 ¹⁾	Out	Keyboard column 2, optionally I/O pin
12	KBC3 ¹⁾	Out	Keyboard column 3, optionally I/O pin
13	KBC4 ¹⁾	Out	Keyboard column 4, optionally I/O pin
14	KBC5 ¹⁾	Out	Keyboard column 5, optionally I/O pin
15	KBC6 ¹⁾	Out	Keyboard column 6, optionally I/O pin
16	KBC7 ¹⁾	Out	Keyboard column 7, optionally I/O pin
17	KBC8 ¹⁾	Out	Keyboard column 8, optionally I/O pin
18	I/O5 ¹⁾²⁾ RESET	In/Out In/Out	Digital I/O pin /RESET – Pulling this pin low resets the iLCD module
18	I/O5 ¹⁾	In/Out	Digital I/O pin
19	I/O6 ¹⁾	In/Out	Digital I/O pin
20	GND	-	Ground pin

Note:

1. This pin can be used as a digital input, a push/pull or pull down output or a keyboard column output when the primary function is not enabled.
2. The functionality of this pin depends on the setting of Jumper J2 and J3 on the iLCD panel. If configured as /RESET pin, the board's internal power up reset signal can be seen on this pin as well.

Relays Connector (Relays)

The two relays, which may be connected to the iLCD board, can be supplied using up to 24V. The iLCD module contains a diode for any of the two relays outputs to protect the switching transistor against reverse voltage. To enable the diodes to protect the transistors, the relay supply voltages must be connected to the board too.

Pin	Direction	Description
1	-	Relay 1 positive supply voltage
2	Out	Relay 1 output (minus pin of relay)
3	-	Ground
4	Out	Relay 0 output (minus pin of relay)
5	-	Relay 0 positive supply voltage
6	-	Vcc +5V (optionally 3/3.3V)

Relay 0 can also be used to drive a speaker or buzzer and relay 1 can be used to generate a pulse-width modulated output voltage. Please have a look to the extra document "iLCD Commands" to learn more about how to control these output ports in this case.

Speaker-On Jumper (Spkr On)

When a jumper is connected to this connector, the Relay 0 output is connected to the evaluation board's speaker via a resistor.

Erase Jumper (Erase)

When a jumper is connected to this connector, the iLCD module erases all user data from the Flash memory at boot time. A corresponding message is shown on the LCD. Please remove the jumper after startup to avoid consecutive erasing of Flash contents at the next startup.

Schematic Evaluation Board

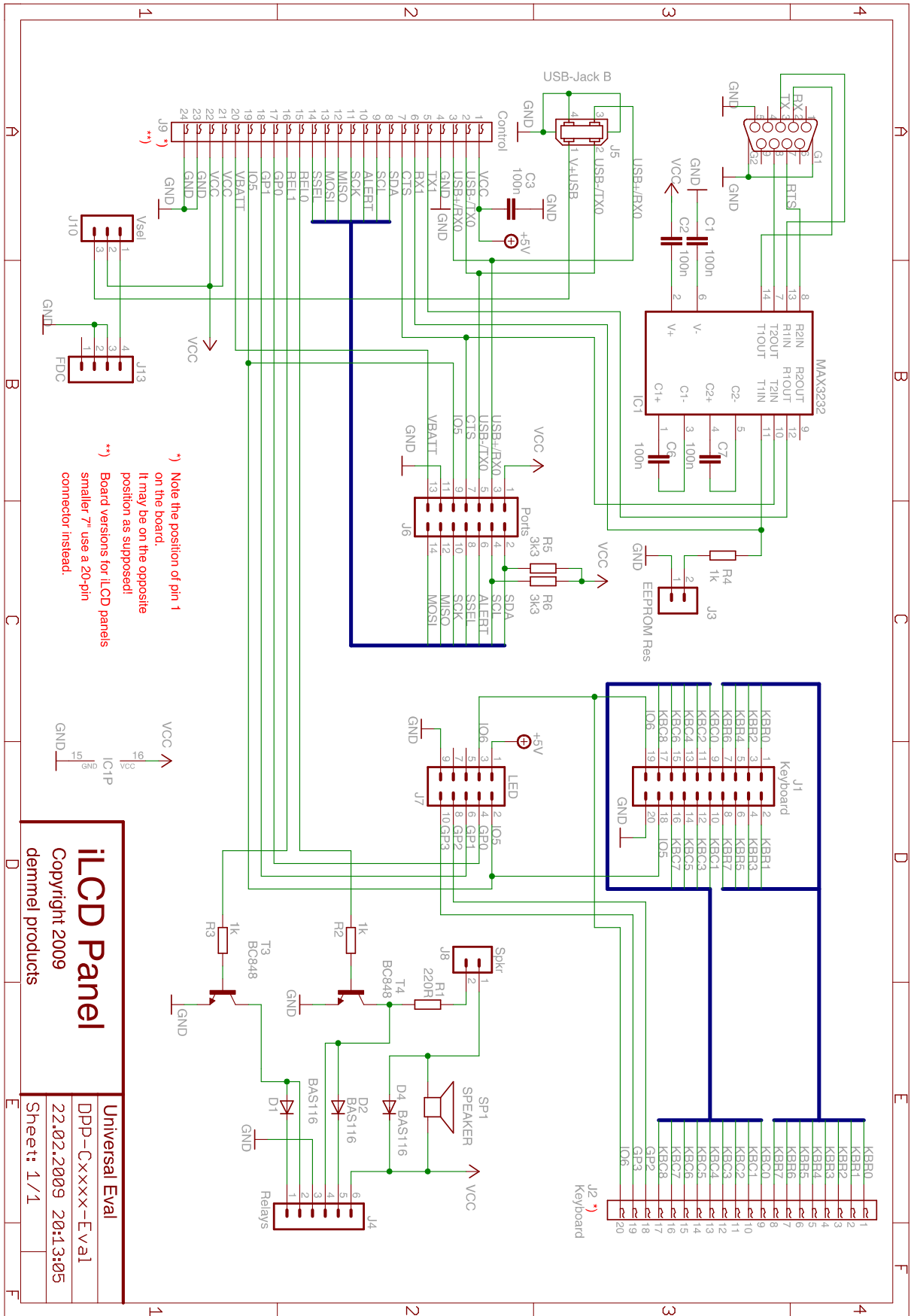

Outline Dimensions

DPP-CTS2432

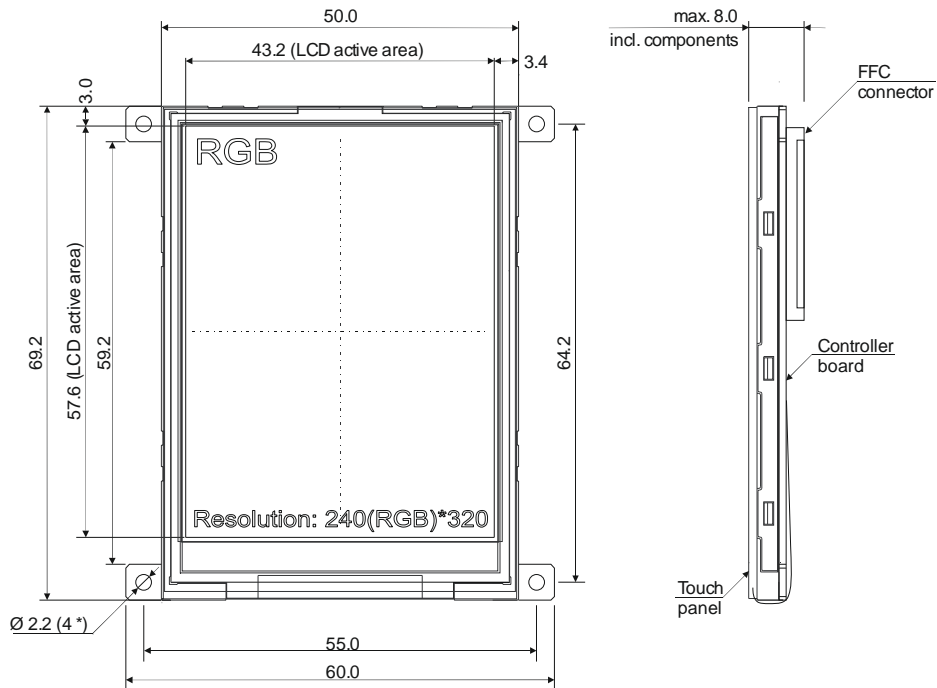

DPP-CTS2440

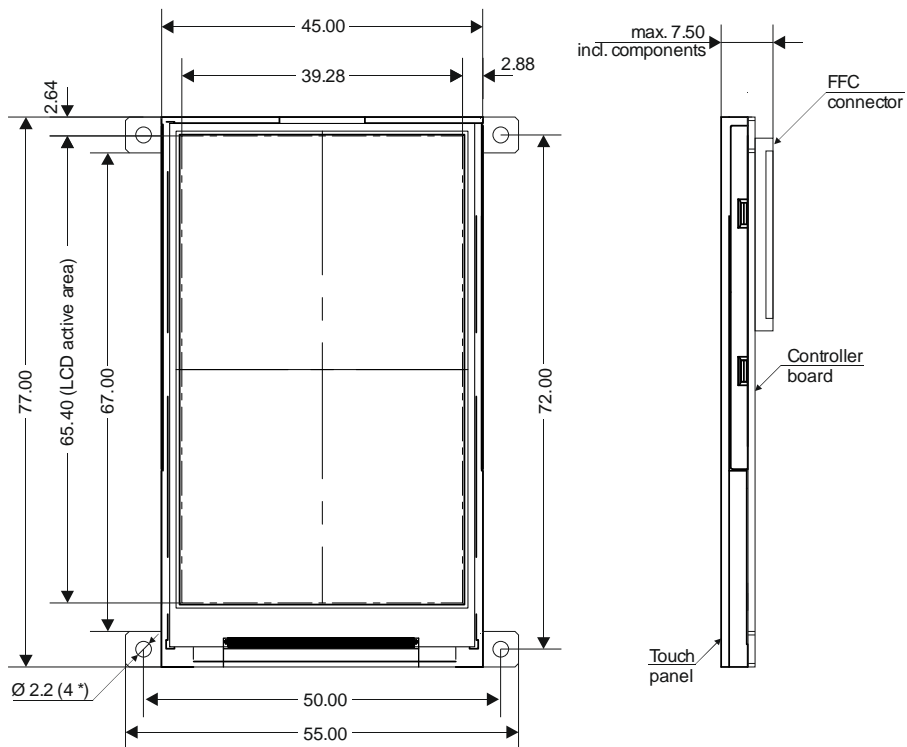

DPP-CTP3224-2

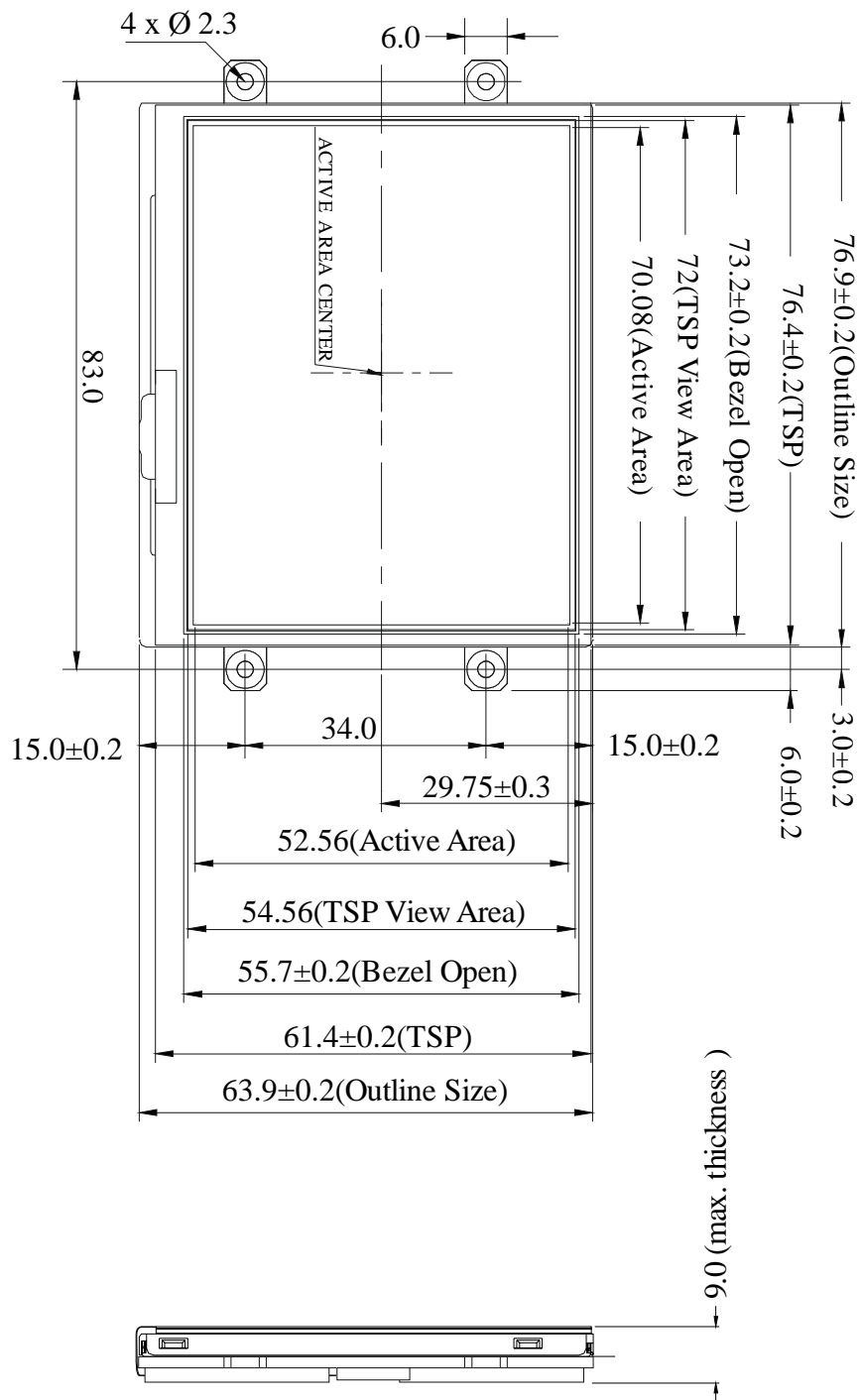

DPP-Cx4827

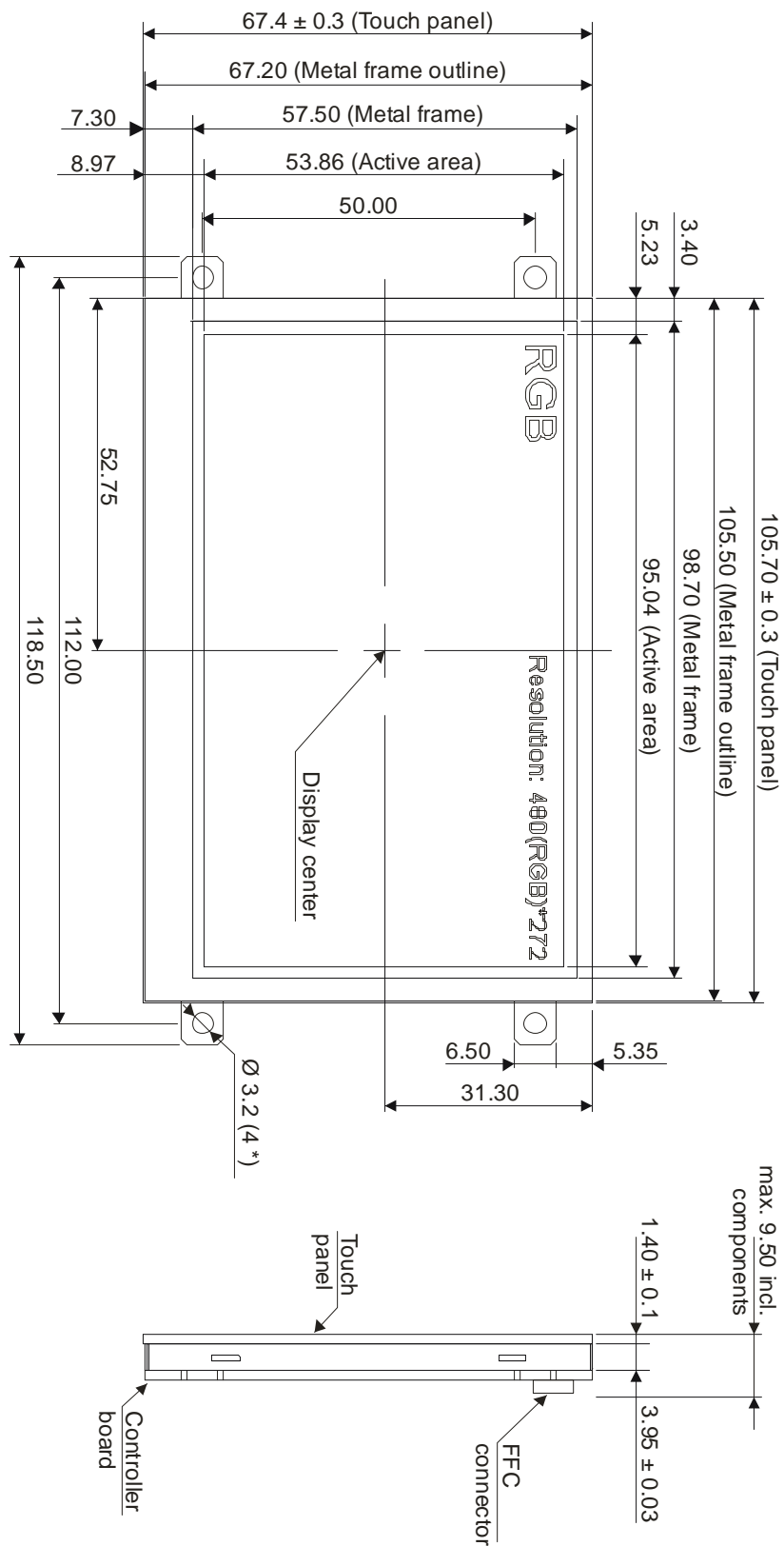

DPP-CT3224-2

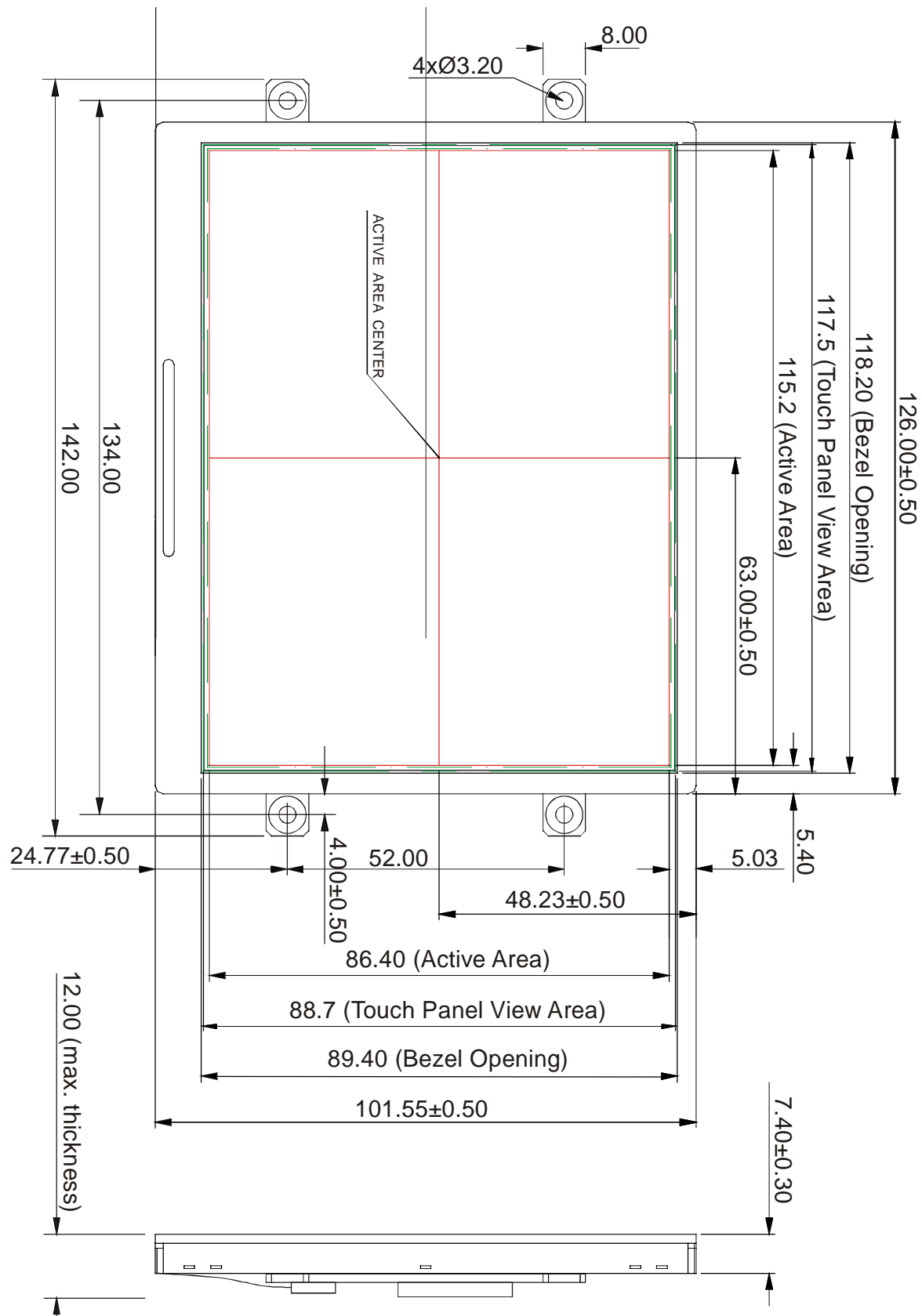

DPP-Cx6448

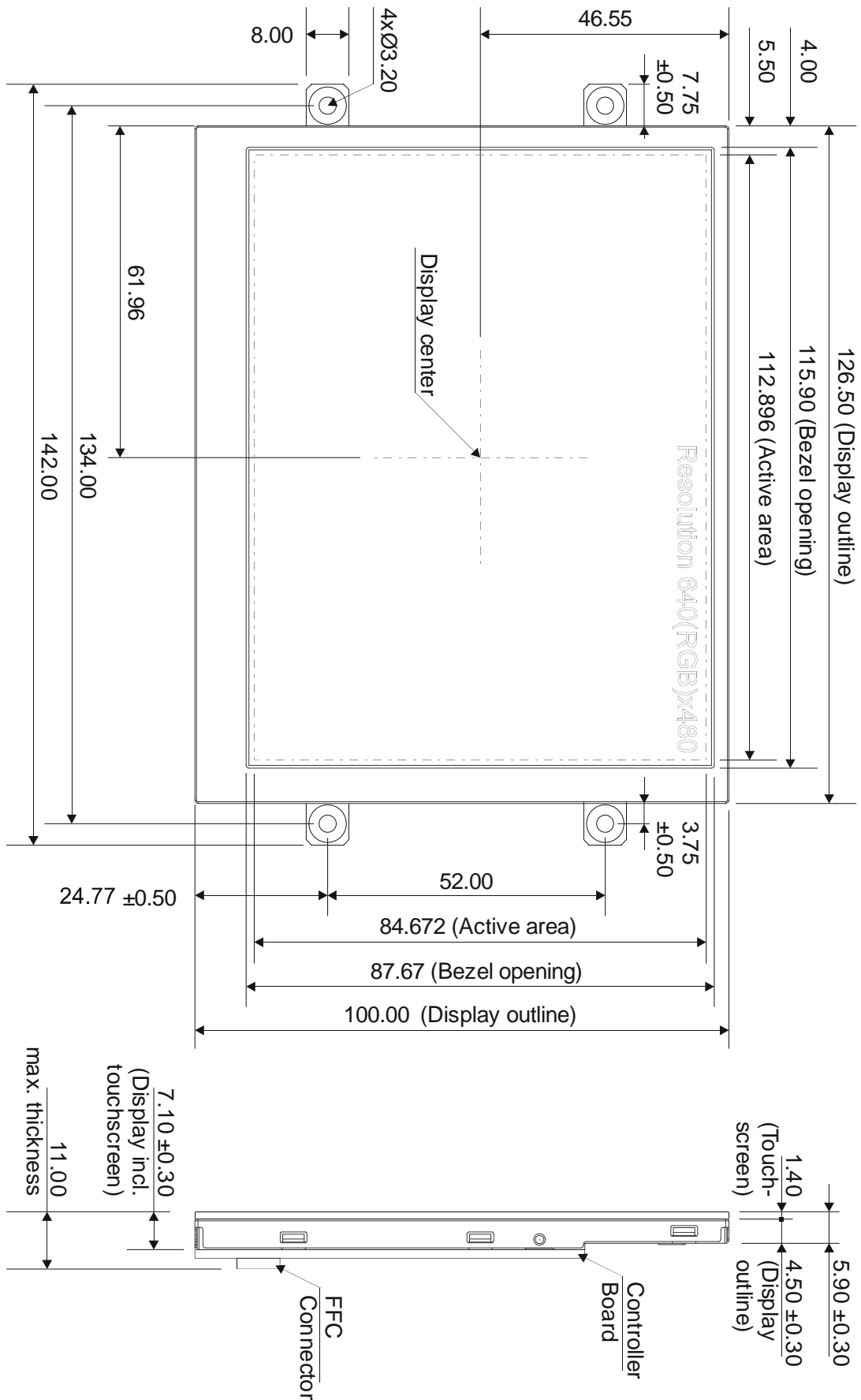

Differences between DPP-CT3224-x and DPP-CT6448

DPP-CT3224-x outline dimensions and differences to DPP-CT6448 are marked in yellow.

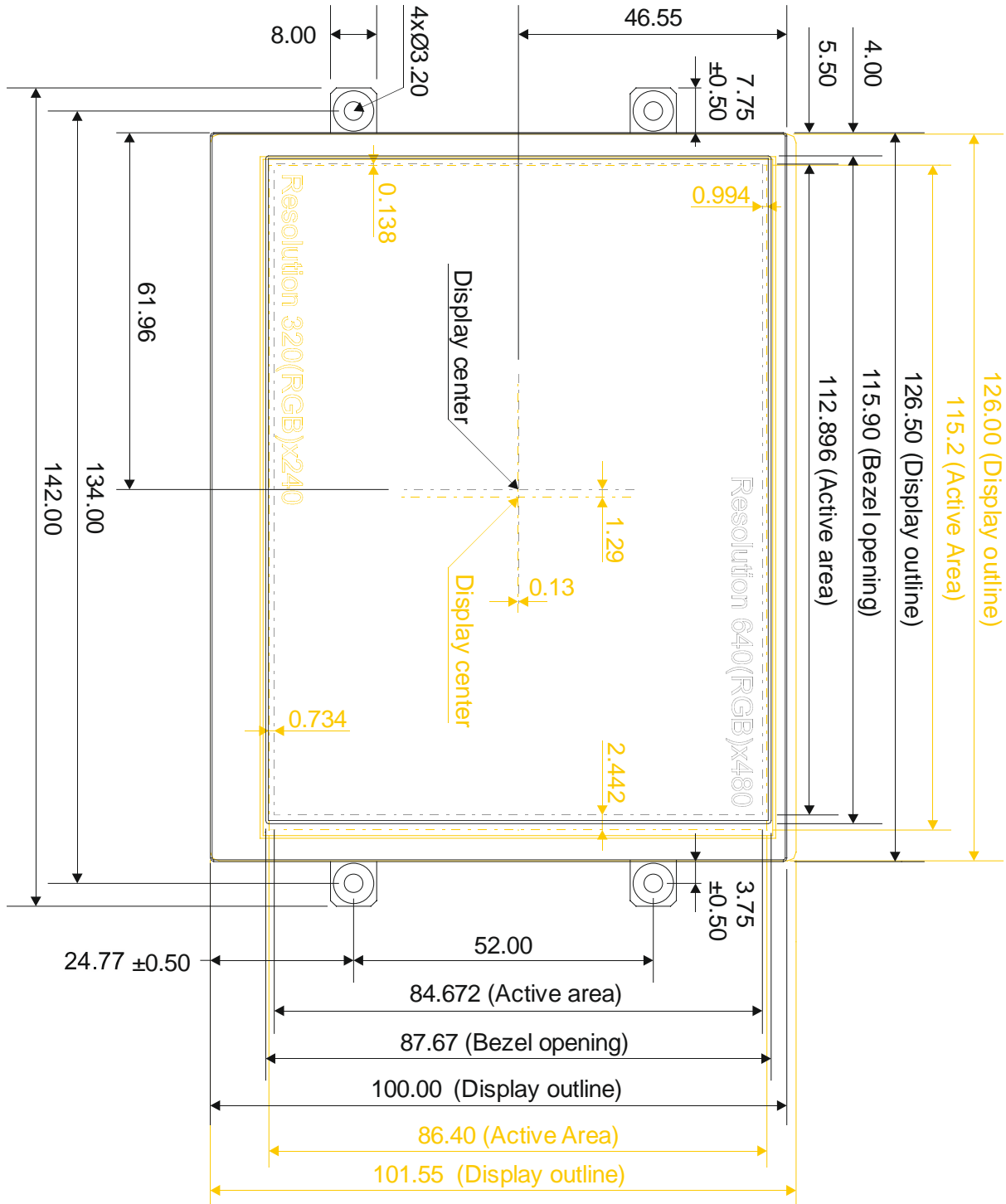

DPP-Cx8048

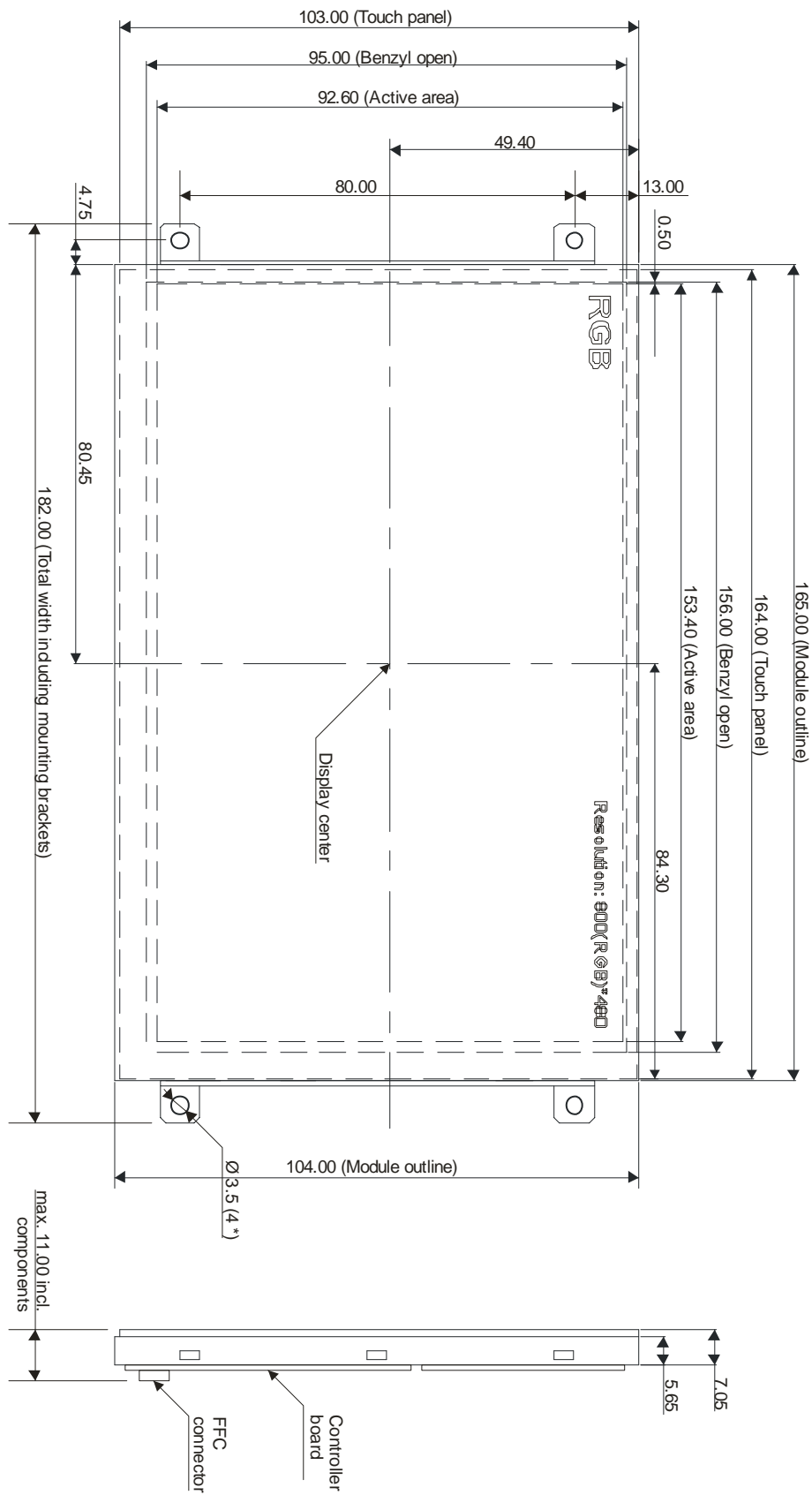

DPP-CT1060

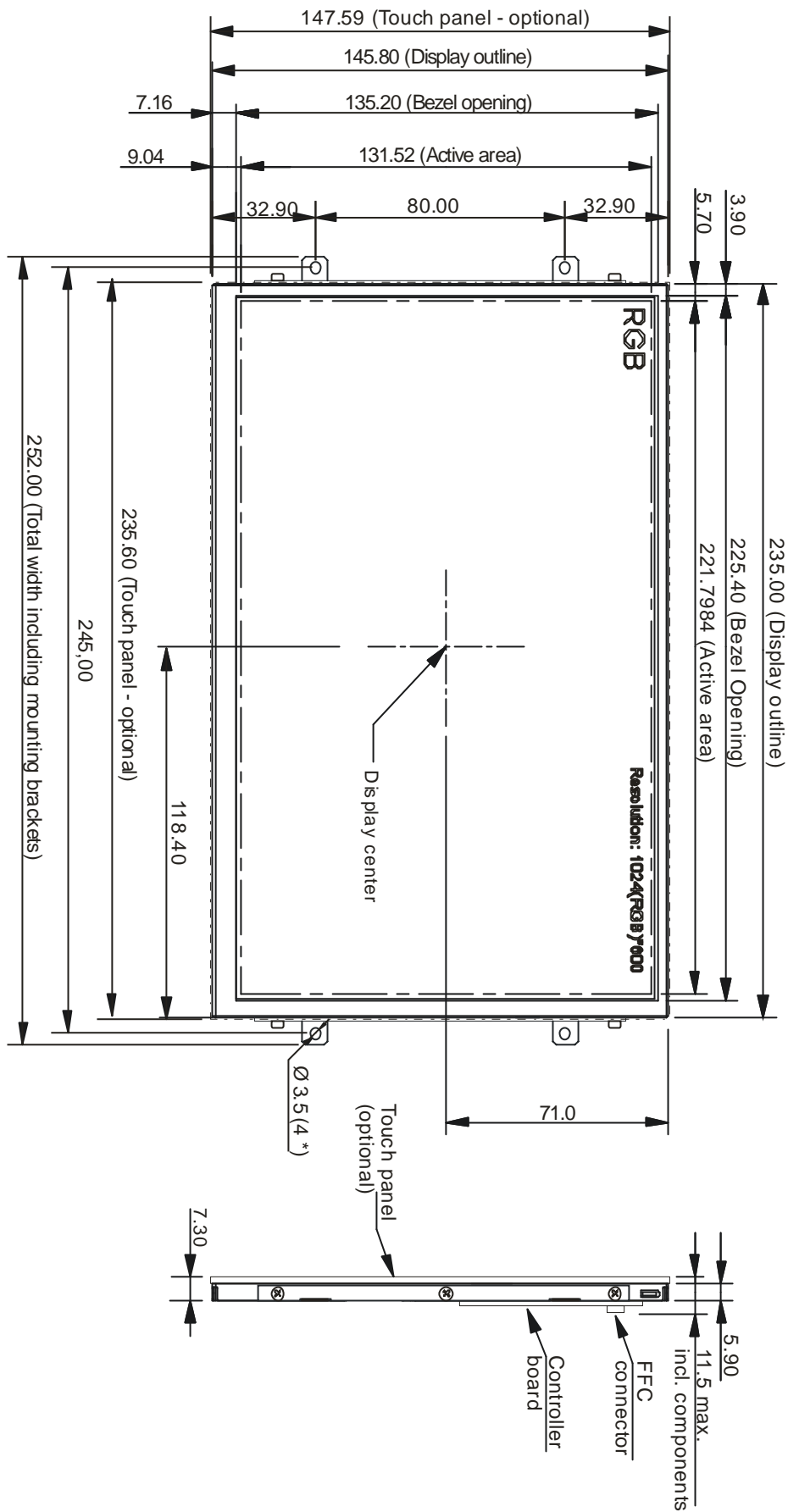

Revision History

Date	Rev. #	Revision Details
August 8, 2011	1.6	Changes of chapter "Important Information about USB and Serial Ports"
May 13, 2011	1.5	Added new board versions for DPP-Cx4827, DPP-Cx6448 and DPP-Cx1064
September 16, 2010	1.4	Added description for DPP-CTS2440 and DPP-Cx6448
February 22, 2010	1.3	Added description for DPP-CTS2432 and DPP-CxP3224-2
September 28, 2009	1.2	Added description for DPP-CT3224-2
February 23, 2009	1.1	Added description for DPP-Cx4827
October 26, 2008	1.0	Initial release

If you find any errors in this document, please contact demmel products at support@demmel.com