

RoHS  **807 Series Fuse**



Description

TE7 807 Series is a time lag type subminiature fuse designed for overcurrent protection. It is 300V rated and designed in accordance to IEC 60127-4.



Features

- Lead-free and RoHS Compliant
- Reduced PCB space requirements
- Direct solderable or plug-in versions
- Low internal resistance
- Shock safe casing
- Vibration resistant
- Halogen Free

Applications

- Battery Charger
- Consumer Electronics
- Power Supplies
- Industrial Controllers

Agency Approvals

Agency	Agency File Number	Ampere Range
	E67006	800mA – 6.3A
	SU05024-10004 to 10005	800mA – 6.3A
	JET1896-31007-2004 JET1896-31007-2005	5A and Less Above 5A

Electrical Characteristics for Series

% of Ampere Rating	Opening Time
125%	3600 secs., Minimum
200%	120 secs., Maximum
1000%	100 milliseconds Minimum 1 secs., Maximum

Electrical Characteristic Specifications by Item

Amp Code	Amp Rating	Voltage Rating (V)	Interrupting Rating 50-60Hz/cos φ = 1	Voltage Drop 1.0 x I _N max [mV]	Power Dissipation 1.25 x I _N max [mW]	Melting Integral 10 x I _N min [A ² s]	Agency Approvals		
									
0800	800mA	300V	100A/300 VAC	218	332	11.7	•	•	•
1100	1.00A	300V		171	324	19.8	•	•	•
1125	1.25A	300V		151	352	29.7	•	•	•
1160	1.60A	300V		135	464	51.2	•	•	•
1200	2.00A	300V		183	486	93.1	•	•	•
1250	2.50A	300V		118	675	141.3	•	•	•
1315	3.15A	300V		163	818	197.3	•	•	•
1400	4.00A	300V		128	945	281.6	•	•	•
1500	5.00A	300V		98	1091	625.4	•	•	•
1630	6.30A	300V		78	1125	1063.2	•	•	•

807 Series

Temperature De-rating Curve



Average Time Current Curves



Soldering Parameters - Wave Soldering



Recommended Process Parameters:

Wave Parameter	Lead-Free Recommendation
Preheat: (Depends on Flux Activation Temperature)	(Typical Industry Recommendation)
Temperature Minimum:	100°C
Temperature Maximum:	150°C
Preheat Time:	60-180 seconds
Solder Pot Temperature:	260°C Maximum
Solder Dwell Time:	2-5 seconds

Recommended Hand-Solder Parameters:

Solder Iron Temperature: 350°C ± 5°C
 Heating Time: 5 seconds maximum

Note: These devices are not recommended for IR or Convection Reflow Process.

Product Characteristics

Materials	Base/Cap: Brown Thermoplastic Polyamide, UL 94V-0 Round Pins: Copper, Sn Plated
Lead Pull Strength	10 N (EN 60068-2-21)
Solderability	260°C, ≤ 3s (Wave) 350°C, ≤ 1s (Soldering Iron)
Soldering Heat Resistance	260°C, 10s (IEC 60068-2-20) 350°C, 3s (Soldering Iron)

Operating Temperature	-40°C to +125°C (consider de-rating)
Climatic Category	-40°C/+85°C/21 days (EN 60068-1, -2-1, -2-2, -2-78)
Stock Conditions	+10°C to +60°C relative humidity 75% yearly average, without dew, maximum value for 30 days – 95%
Vibration Resistance	24 cycles at 15 min. each (EN60028-2-6) 10 - 60Hz at 0.75 mm amplitude 20 – 2000Hz at 10g acceleration

Dimensions

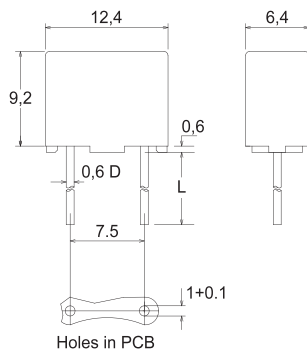

LONG LEADS (L=18.8 +/-0.3mm)
SHORT LEADS (L=4.3 +/-0.3mm)

Part Numbering System

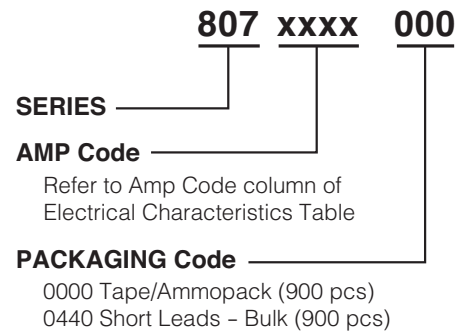

Packaging

Packaging Option	Packaging Specification	Quantity	Quantity & Packaging Code	Reel Size
807 Series				
Tape & Ammopack	N/A	1,000	000	N/A
Short Leads	N/A	1,000	044	N/A