



US-9001D

UHF PLL

US-901D

WIRELESS SYSTEMS

Instruction Manual

Thank you for choosing the JTS wireless system. In order to obtain the best efficiency from the system, you are recommended to take few minutes to read this instruction manual carefully.

INDEX

1. Important Caution	1
2. Features	1
3. Specification	2
3-1 Receiver// US-901D US-9001D	2
3-2 Handheld Transmitter // Mh-950 Mh-960 Mh-8900(i)	3
3-3 Body-pack Transmitter // PT-950B(mi)	4
3-4 Optional Condenser Microphone	4
4. Part Identification & Accessories	7
4-1 Receiver // US-901D US-9001D	7
4-2 Handheld Transmitter // Mh-950 Mh-960 Mh-8900(i)	8
4-3 Body-pack Transmitter // PT-950B(mi)	9
4-4 Optional Condenser Microphone	9
4-5 Accessories	12
5. Preparing Procedures & Basic Operation	13
5-1 Receiver// US-901D US-9001D	13
5-2 Handheld Transmitter // Mh-950 Mh-960	16
5-3 Handheld Transmitter // Mh-8900(i)	18
5-4 Body-pack Transmitter // PT-950B(mi)	22
6. Recommendation	24

1. Important Caution

- Always make all connections before plugging the unit into an AC power outlet.
- Do not leave the devices in a place neither with high temperature nor high humidity.
- Always do not handle the power cord with wet hands !
- Keep the devices away from fire and heat sources.

2. Features

- Operated in UHF band where there is less RF interference than the VHF band.
- Due to the PLL synthesized technology, the system can offer up to 961 selectable frequencies for choosing simultaneously.
- The true diversity reception with 2 independent RF receivers ensure the stable transmission and reception.
- Adjustable Pilot tone squelch control can effectively reduce the noise.
- Equipped with S.A.W. filter benefits the interference-resistant.
- Tuned antennas can benefit the stable RF reception.
- Built-in Noise Squelch circuitry & Mute function are available to restrain the interference for signals.
- Compact half-rack receiver design is considerable for the space saving.
- Rugged metal housing can pass through the difficult environment.
- Equipped with balanced XLR and unbalanced output allow great convenience.
- Anti-interference design is available to work with every computer device.

3. Specification

3-1 Receiver // US-901D US-9001D

Frequency Preparation.....	PLL Synthesized Control
Carrier Frequency Range	502-960 MHz
S/N Ratio.....	> 105dB
T.H.D.....	<0.6%@1KHz
Display.....	LCD
Display Contents.....	Frequency, Antenna A/B, Mute Display, RF/AF Level Meter, Battery Fuel Gauge
Controls.....	Power On/Off, Frequency Up/Down, Frequency Scan, Audio Level, Lock-on
Audio Output Level.....	-12dB
AF Output Impedance.....	600Ω
Squelch.....	Pilot Tone & Noise Mute
Operation Voltage.....	12-18 VDC, 200 mA
Output Connector.....	1 XLR Balanced Socket 1 Ø6.3mm Unbalanced phone jack
Dimension(m/m).....	US-901D: 211mm (W)* 40mm (H)* 125mm (D) US-9001D: 211mm (W)* 40mm (H)* 137mm (D)

3-2 Handheld Transmitter // Mh-950 Mh-960

Frequency Preparation.....	PLL Synthesized Control
Carrier Frequency Range.....	502~960 MHz
RF Outputs.....	10mW
Stability.....	±10KHz
Frequency Deviation.....	±48KHz
LCD Display.....	Frequency, Battery Fuel Gauge, Sensitivity
Controls.....	Power On/Off, Mode Setting, AF Level, Frequency Up/Down, Lock-on Mode
Spurious Emissions.....	<-50 dBC
Audio Frequency Response	50~16,000 Hz
Battery.....	UM3, AA 1.5V*2

Handheld Transmitter // Mh-8900(i)

Frequency Preparatio.....	PLL Synthesized Control
Carrier Frequency Range.....	502~960 MHz
RF Outputs.....	10mW
Stability.....	±10KHz
Frequency Deviation.....	±48KHz
LCD Display.....	Frequency, Battery Fuel Gauge, Sensitivity
Controls.....	Power On/Off, Mode Setting, AF Level, Frequency Up/Down, Lock-on Mode
Spurious Emissions.....	<-60 dBC
Audio Frequency Response	50~16,000 Hz
Battery.....	UM3, AA 1.5V*2

3-3 Body-pack Transmitter // PT-950B(mi)

Frequency Preparation.....	PLL Synthesized Control
Carrier Frequency Range.....	502~960 MHz
RF Outputs.....	10mW
Stability.....	±10KHz
Frequency Deviation.....	±48KHz
LCD Display.....	Frequency, Battery Fuel Gauge
Controls.....	Power On/Off, AF Level, Frequency Up/Down, Lock-on Mode
Spurious Emissions.....	<-50 dBC
Audio Frequency Response	40~18,000 Hz
Battery.....	UM3, AA 1.5V*2

3-4 Optional Condenser Microphone

Lavaliere Microphone // CM-501 CM-201 CM-125

Model No.....	CM-501	CM-201	CM-125
Connector.....	4P Mini XLR	4P Mini XLR	4P Mini XLR
Frequency Response.....	100~15,000 Hz	60~15,000 Hz	50~18,000 Hz
Polar Pattern.....	Cardioid	Omni-directional	Omni-directional
Sensitivity (at 1000Hz)	-60±3 dB	-60±3 dB	-53±3 dB
Impedance.....	2.2kΩ	2.2kΩ	4.4kΩ
Max. SPL for 1% THD	130dB	130dB	130dB
Dimension(mm).....	Ø10.1mm(W) * 26.4mm(H)	Ø5mm(W)* 9mm(H)	Ø4mm(W)* 11mm(H)
Net Weight.....	21.5g	20.7g	7g (cable excluded)

Headset Microphone // CM-204 CM-204U CM-204UL CM-225 CX-504

Model No.....	CM-204	CM-204U	CM-204UL
Connector.....	4P Mini XLR	4P Mini XLR	801C3 (3 pin mini XLR) 801C4 (4 pin mini XLR) 801CS (3.5 stereo plug)
Frequency Response.....	60~15,000 Hz	30~18,000 Hz	100 ~ 18,000Hz
Polar Pattern.....	Omni-directional	Cardioid	Cardioid
Sensitivity (at 1000Hz)	-60±3 dB	-68±3 dB	-75±3 dB
Impedance.....	2.2kΩ	680Ω	1.5kΩ
Max. SPL for 1% THD	130dB	130dB	120dB
Dimension(mm).....	125mm(W) * 134mm(H) * 157mm(D)	205mm(W) * 134mm(H) * 157mm(D)	125mm(W)*134mm(H) * 157mm(D)
Net Weight.....	32.9g	38.4g	18g (cable excluded)

Model No.....	CM-225	CX-504
Connector.....	4P Mini XLR	4P Mini XLR
Frequency Response.....	50~18,000 Hz	30~18,000 Hz
Polar Pattern.....	Omni-directional	Cardioid
Sensitivity (at 1000Hz)	-53±3 dB	-68±3 dB
Impedance.....	4.4kΩ	680Ω
Max. SPL for 1% THD	130dB	130dB
Dimension(mm).....	155mm(W) * 134mm(H) * 157mm(D)	285mm(W) * 55mm(H) * 111.3mm(D)
Net Weight.....	17g (cable excluded)	56.3g

Ear-hook Microphone // CM-801 CM-804i CM-8015 CM-825i

Model No.....	CM-801/CM-804i	CM-8015/CM-825i
Connector.....	801C3 (3 pin mini XLR) 801C4 (4 pin mini XLR) 801CS (3.5 stereo plug)	801C3 (3 pin mini XLR) 801C4 (4 pin mini XLR) 801CS (3.5 stereo plug)
Frequency Response.....	60 ~ 15,000Hz	50 ~ 18,000Hz
Polar Pattern.....	Omni-directional	Omni-directional
Sensitivity (at 1000Hz)	-64±3 dB	-53±3 dB
Impedance.....	1.8kΩ	1.2kΩ
Max. SPL for 1% THD	130dB	130dB

Instrument Microphone // CX-508W CX-516W

Model No.....	CX-508W	CX-516W
Connector.....	4P Mini XLR	4P Mini XLR
Frequency Response.....	50~18,000 Hz	50~18,000 Hz
Polar Pattern.....	Cardioid	Cardioid
Sensitivity (at 1000Hz)	-67±3 dB	-67±3 dB
Impedance.....	220Ω	220Ω
Max. SPL for 1% THD	130 dB	130 dB

4. Parts Identification & Accessories

4-1 Receiver // US-901D US-9001D

- ① Power On/Off switch
- ② Up button (frequency adjustment)
- ③ Down button (frequency adjustment)
- ④ Set button (frequency adjustment)
- ⑤ LCD Display
- ⑥ Volume control
- ⑦ DC socket for connection of main unit
- ⑧ AF output, jack socket (AF UNBAL)
- ⑨ Balanced XLR socket
- ⑩ Antenna input socket
- ⑪ Antenna

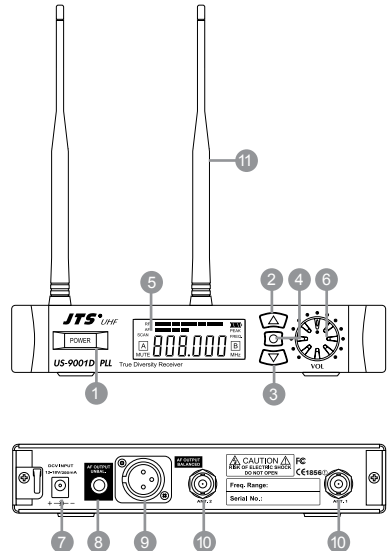
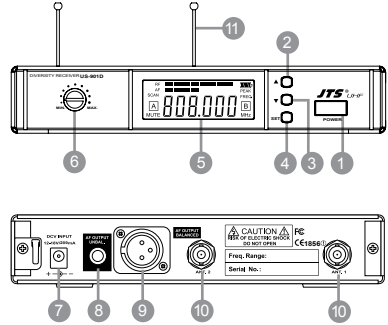

4-2 Handheld Transmitter // Mh-8900(i) Mh-950 Mh-960

- 12 Interchangeable dynamic capsule
- 13 LCD display
- 14 Down button
- 15 UP button
- 16 Set button
- 17 Battery tray button
- 18 Battery tray
- 19 Power On/Off switch
- 20 Mute On/Off switch

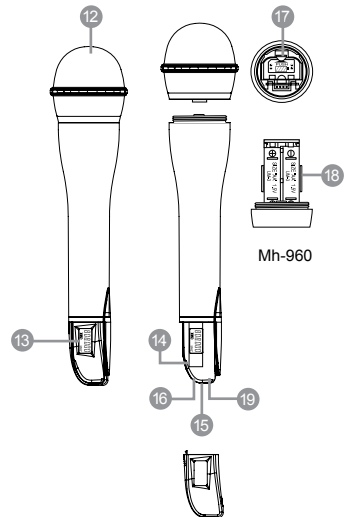
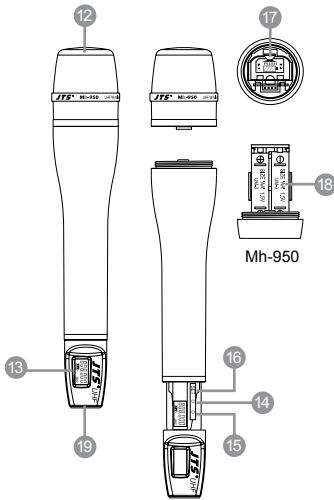
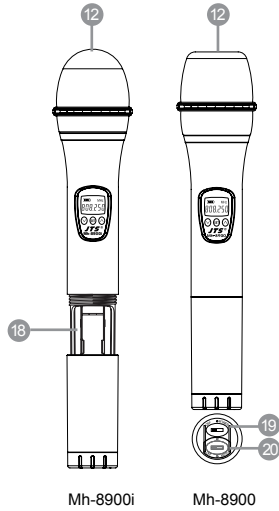
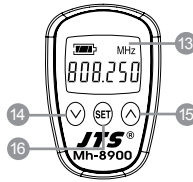

4-3 Body-pack Transmitter // PT-950B(mi)

- 21 Mic. input
- 22 Power On/off switch
- 23 Antenna
- 24 LCD display
- 25 Set button
- 26 Up button
- 27 Down button
- 28 Battery tray button
- 29 AF level control
- 30 Belt clip
- 31 Battery tray
- 32 Attenuation pad

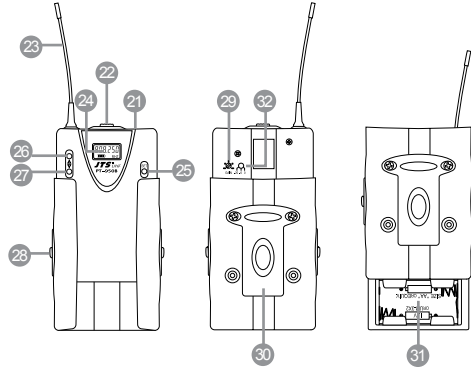

4-4 Optional Condenser Microphone

Lavaliere Microphone // CM-501 CM-201 CM-125

- 33 Clip
- 34 4 Pin Mini XLR
- 35 Windscreen

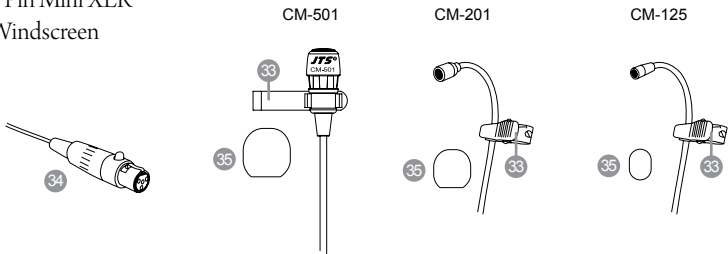

Headset Microphone // CM-204 CM-204U CM-204UL CM-225 CX-504

- 36 Gooseneck
- 37 Headband
- 38 4 Pin Mini XLR
- 39 Windscreen

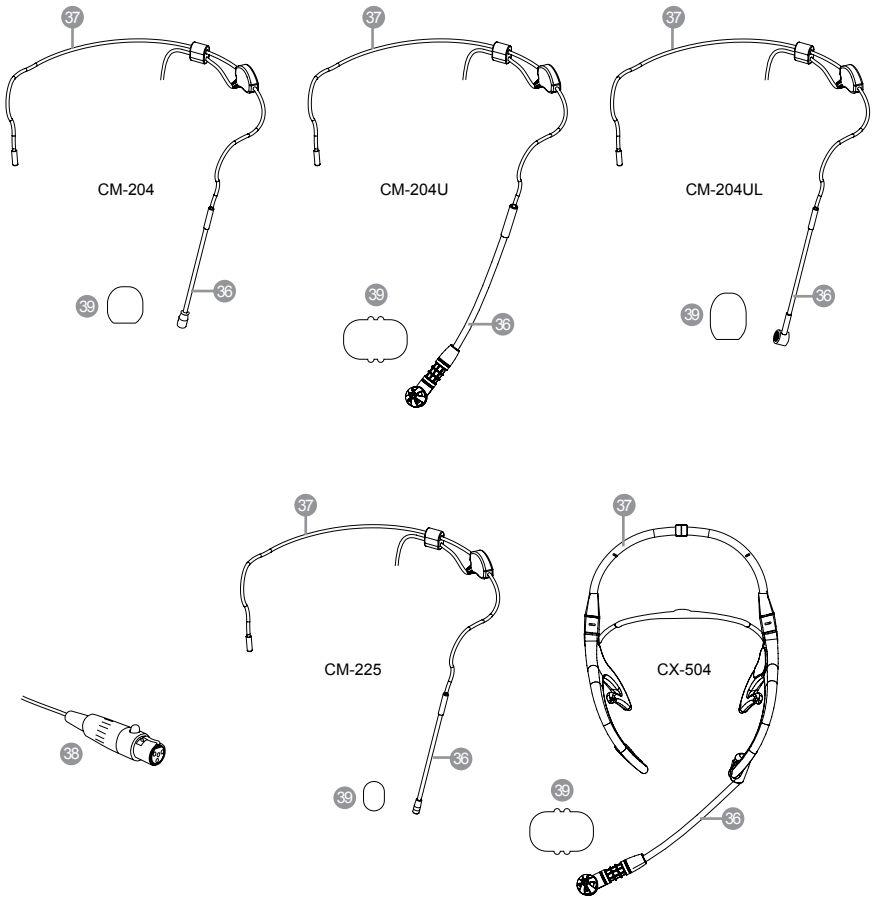

Ear-hook Microphone // CM-801 CM-804i CM-8015 CM-825i

- 40 Boom
- 41 Adjustable Headband
- 42 Adjustable ear hook
- 43 Detchable Cable
- 44 Cable Clip
- 45 Windscreen
- 46 4 Pin Mini XLR
- 47 3 Pin Mini XLR
- 48 3.5 Stereo Plug

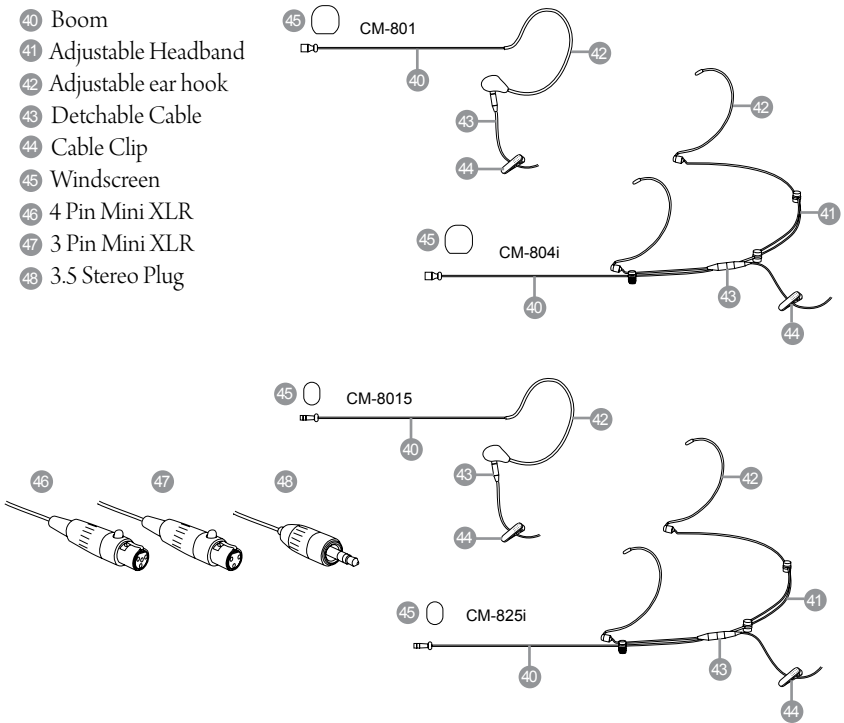

Instrument Microphone // CX-508W CX-516W

- 49 Gooseneck
- 50 Clip
- 51 4 Pin Mini XLR
- 52 Windscreen

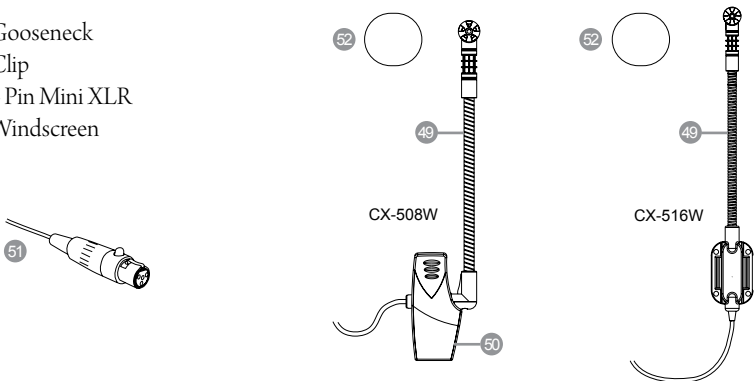

4-5 Accessories

- 53 AC/DC adaptor
 - A Switching Power Supply(100V~240V , 50~60Hz)
 - B Linear Power Supply (220V , 50Hz)
 - C Linear Power Supply (220V , 60Hz)
- 54 Screwdriver
- 55 DR-900 Dual Rack Adaptor **Option**
- 56 RP-900 Panel Cover **Option**
- 57 AF output cable (with $\Phi 6.3$ plug at both ends)
- 58 GC-80/GC-100 Guitar Cable **Option**
- 59 GC-80L/GC-100L Guitar Cable **Option**

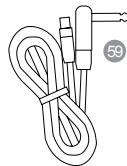
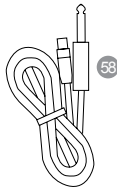
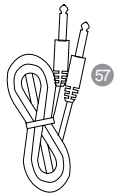
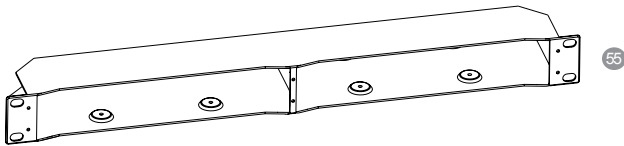
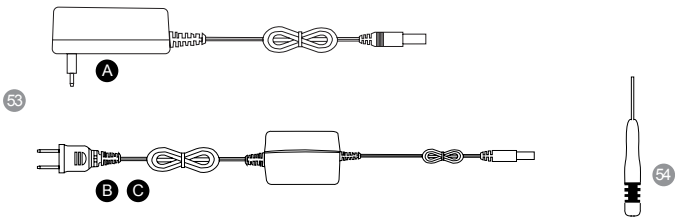

5. Preparing Procedures & Basic Operation

5-1 Receiver // US-901D US-9001D

(1) Power output connector

Plug in one end of AC/DC adaptor cable to DC input socket in the rear panel of receiver, and plug another end into an AC outlet.(Step 1)

(2) Audio Output Connector

Connect one end of the AF output cable to the AF output socket in the rear panel, then plug another end to the “MIC IN” input socket of a mixer or amplifier.(Step 2)

Receiver equipped with balanced XLR output and Unbalanced $\phi 6.3\text{mm}$ output, choose the proper way for use.

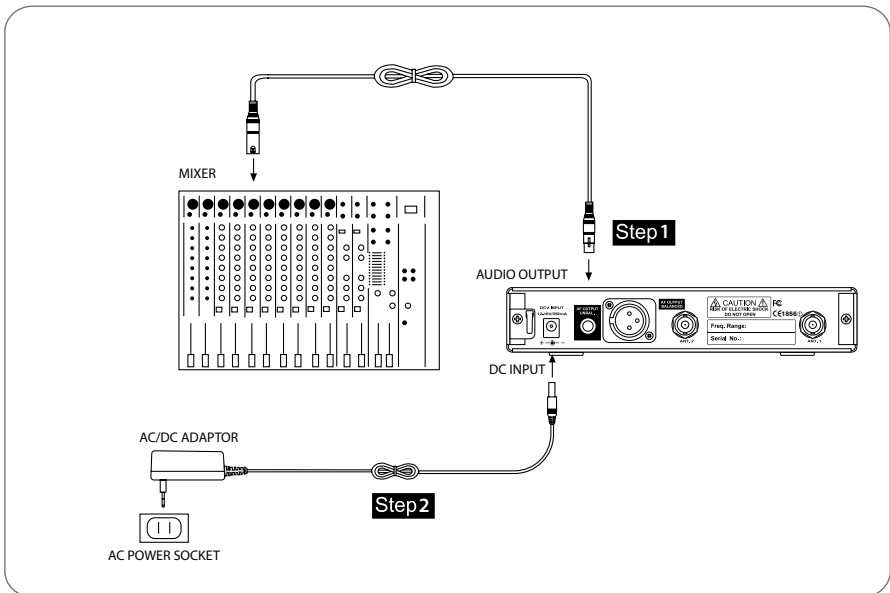

(3) LCD panel

- 60 AF signal
- 61 RF signal
- 62 Display for SCAN mode
- 63 Display for set FREQ.mode
- 64 Main display
- 65 Diversity display (A or B antenna)
- 66 Battery display for the transmitter

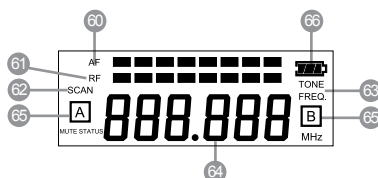

Basic operation

POWER Turning the receiver on and off by pressing the POWER button.

SET Press the SET button for 3 seconds to select frequency and scan.

Press the SET button again to store once you make any changes.

Press the UP or DOWN button to adjust the setting of a menu.

(4) Setting the rubber pad

Four self-adhesive rubber pads are provided to ensure the stability.

They are to be placed on the bottom side of the receiver.

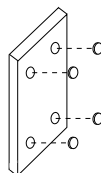

(5) Connecting the antennas

The user-friendly receiver antenna comes with easy mount on socket for effortless connection. Connect two antennas on the back of the receiver and align them upward.

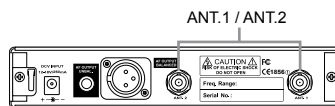

(6) Connecting the main unit

Plug in the DC connector on the back of the receiver (DCV INPUT).

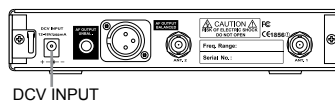

(7) Connecting the amplifier/mixer console

Plug in the amplifier/mixer console to the (AF OUT UNBAL / BAL) sockets.

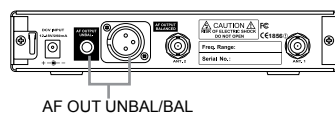

- (8) Turning the receiver on/off
Turn the receiver on by pressing the (POWER) button.

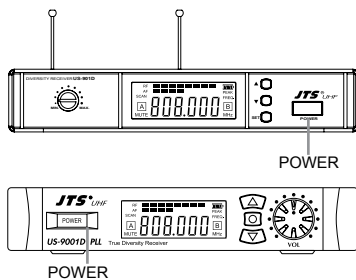

- (9) Adjusting the AF output level
Use the AF output level control located on the front side of the receiver to adjust the AF signal level that appears at output.

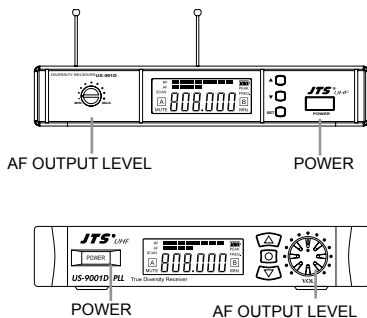

- (10) Dual Rack Adaptor set
The dual rack adaptor is available to unify the half rack space into a standard EIA size with single or dual units.

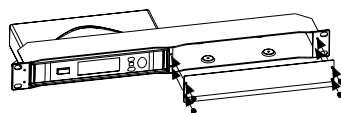

5-2 Handheld Transmitter // Mh-950 Mh-960

(1) Turning the transmitter on/off

The on/off switch is located on the bottom of the microphone.

(2) Inserting and changing the battery

1. Loosen the microphone head counter-clockwise. (Figure 1)
2. Hold on to both battery tray buttons to release it. (Figure 2)
3. Insert 2 pieces of UM-3 1.5 V batteries, remember to match correct polarity. (step1 of Figure3)
4. Directly push the battery tray back. (step2 of Figure3)
5. Aim the connectors exactly for screwing on the microphone head clockwise. (Figure 4)

(3) LCDpanel

- 69 Main display
- 70 Battery indicator

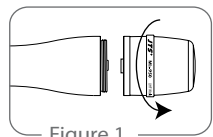

Figure 1

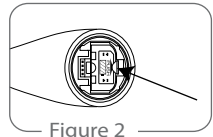

Figure 2

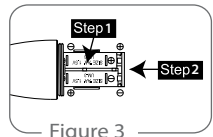

Figure 3

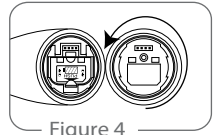

Figure 4

(4) Mh-950 Press the SET button to select between frequency and sensitivity.

1. Frequency adjusting

Press the UP or DOWN button to adjust the setting of a menu.

1-1 Hold SET button for 3 seconds to activate frequency.

1-2 Once you see "MHz" blanking, you are ready to select your desired frequency by using UP and DOWN buttons.

1-3 Press the SET button again to store your changes.

2. Sensitivity adjusting

2-1 Press the SET button twice to select sensitivity. Lasting for 3 seconds at the first press, then 1 second for the second press, and the display appears 5E n 5 i t .

2-2 Use UP and DOWN buttons to adjust changes.

2-3 Finally press SET button again to store your changes.

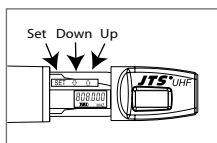

(5) Mh-960 Press the SET button to select between frequency and sensitivity.

1. Frequency adjusting

Press the UP or DOWN button to adjust the setting of a menu.

1-1 Hold SET button for 3 seconds to activate frequency.

1-2 Once you see "MHz" blanking, you are ready to select your desired frequency by using UP and DOWN buttons.

1-3 Press the SET button again to store your changes.

2. Sensitivity adjusting

2-1 Press the SET button twice to select sensitivity. Lasting for 3 seconds at the first press, then 1 second for the second press, and the display appears 5E n 5 i t .

2-2 Use UP and DOWN buttons to adjust changes.

2-3 Finally press SET button again to store your changes.

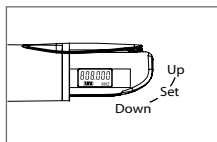

5-3 Handheld Transmitter // Mh-8900(i)

- (1) Insert 2 pcs 1.5V batteries into the battery tray. 17
- (2) After putting into the battery, switch on the power on/off. 18
- (3) LCD operation
 - 14 Down button
 - 15 Up button
 - 16 SET button

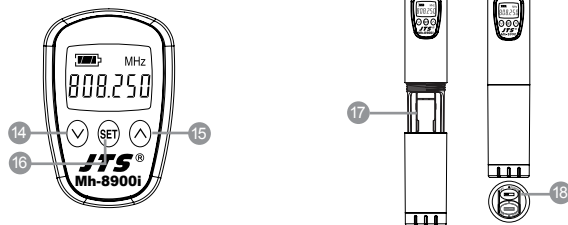

(4) Relieved Lock-on

Press "SET" button three sec. till "L o c k o n" show up, then press "DOWN" button plus "SET" button to store the lock-on relieved.

1. Press any button the display shows "L o c k o n" during lock-on model. And it will not disappeared either electric off.

2. Mh-8990 Press the SET button to select between frequency and sensitivity.

2-1 Frequency adjusting

Press the UP or DOWN button to adjust the setting of a menu.

1. Hold SET button for 3 seconds to activate frequency.

2. Once you see "MHz" blanking, you are ready to select your desired frequency by using UP and DOWN buttons.

3. Press the SET button again to store your changes.

2-2 Sensitivity adjusting

1. Press the SET button twice to select sensitivity. Lasting for 3 seconds at the first press, then 1 second for the second press, and the display appears “5E n5 i t”.
2. Use UP and DOWN buttons to adjust changes.
3. Finally press SET button again to store your changes.

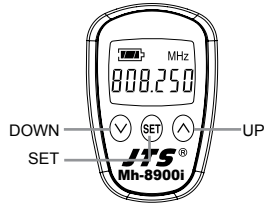

2-3 UP button to activate “Lock mode”

- Hold on to UP button for 3 seconds to activate “Lock mode”, press again to unlock.
(Prevent accidental programming or switching off)

5-4 Body-pack Transmitter // PT-950B(mi)

(1) Turning the transmitter on/off

The on/off switch is located on the top of the transmitter.

(2) Inserting and changing the battery

1. The battery tray is located on the back of the transmitter.
2. Hold on to both belt clip buttons to release it.

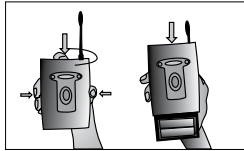

3. Insert 2 pieces of UM-3 1.5V batteries. Remember to match correct polarity.

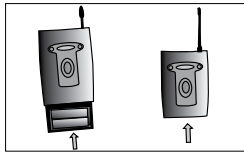

4. Directly slide the belt clip back.

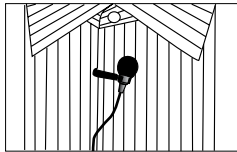

(3) With Lavalier microphone

Attach Lavalier microphone to clothing, tie, lapel, where is the suitable place of sound pick-up. Plug the mini XLR on the microphone cable into the “MIC. IN” on the body-pack transmitter.

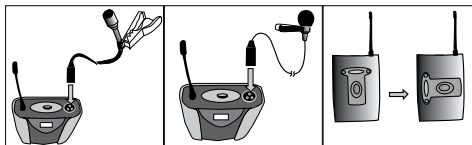

(4.) With Headset microphone

Put the neck-frame behind your neck meanwhile fix the temples on your ears. Adjust the gooseneck to aim the microphone toward the suitable sound source, which is about 1.5-2 inches distance from your mouth. Plug the mini XLR on the microphone cable into the "MIC. IN" on the body-pack transmitter.

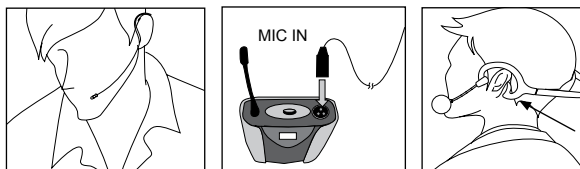

(5) With Wind Microphone

1. Outstanding for saxophone, brass, woodwind instruments.
2. Flexible gooseneck together with adjustable axis allow accurate sound source aiming.
3. Clamp with elastic grip ensures stable holding instrument without damaging.
4. Windscreens to prevent pop noise effectively.

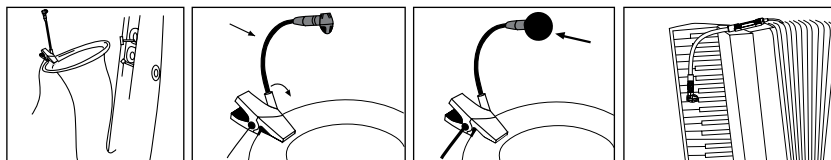

(6) Ear-hook Microphone

1. Lightweight Dual Ear Hook Microphone

Try on whether the headset is fit.

Adjust the headband to a suitable width.

Tighten or loosen the curve of the ear-hook by twisting the loop or expanding it.

Curve and bend the boom to fit your face.

Attach the detachable cable to a suitable place by a cable clip.

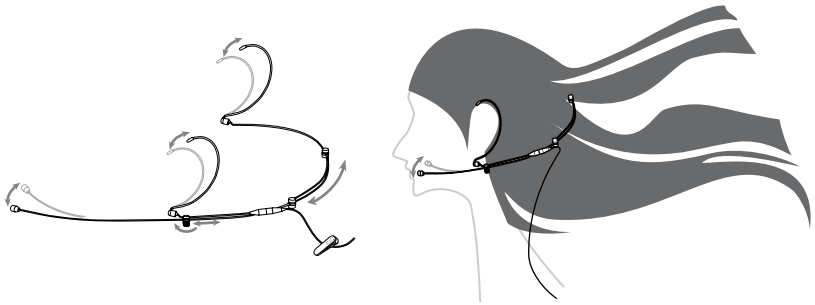

2. Lightweight Single Ear Hook Microphone

Try on whether the original curve is tight or loose.

Re-try and push the fixed curve against your earlobe.

Curve and Bend the boom to fit your face.

Attach the detachable cable to a suitable place by a cable clip.

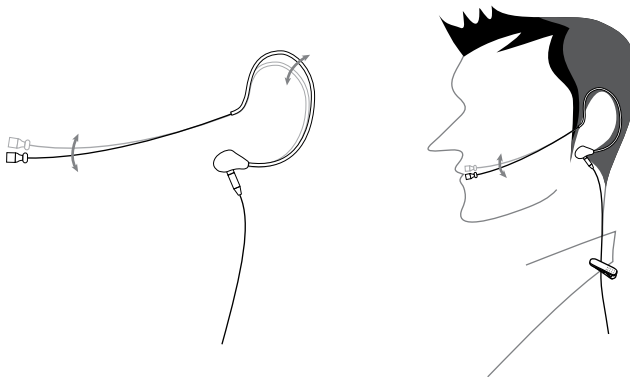

(7) Basic operation

1. Frequency adjusting

1-1 Hold SET button for 3 seconds to activate frequency.

1-2 Once you see “MHz” blanking, you are ready to select your desired frequency by using UP and DOWN buttons.

1-3 Press the SET button again to store your changes.

2. Sensitivity adjusting

The sensitivity control (AF level control) is in the up-left of the transmitter's back. Please use the adjusting sticker to adjust the proper level.

3. To activate “Lock mode”

Hold on to UP button for 3 seconds to activate “Lock mode”, press again to unlock. (Prevent accidental programming or switching off)

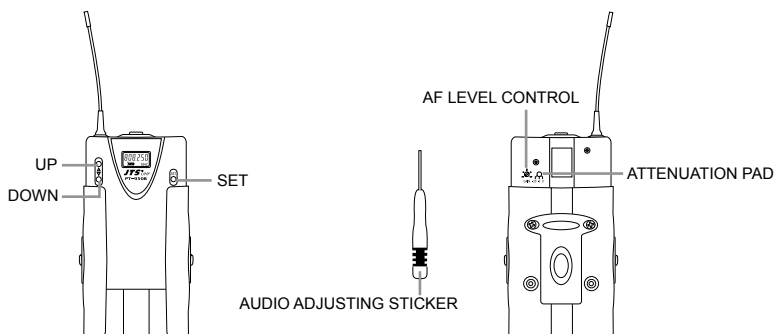

6. Recommendation

- (1) In order to achieve the optimum reception condition and also extend the operating distance, please leave a “open space” between the receiver and transmitter.
- (2) Keep the devices away from the metal objects or any interference sources, at least 50 cm.
- (3) To avoid the feed-back effect, don't leave the mic. to aim at the speakers directly.
- (4) For best pick-up pattern, please hold the middle of the mic. body.
- (5) Remove batteries from the battery compartment when the transmitter will not be used for a long time.
- (6) When you need to replace the batteries, please replace both batteries at the same time with new ones.

JTS®

US-901D/US-9001D
Mh-950/Mh-960/Mh-8900(i)/PT-950B(mi)

RoHS
conform



FC CE1856 ⚠

59506-048-03