



Description 3

Product Assembly 4

Keypads 5

Technical Data..... 6

Drawings..... 7

Index..... 11

Product Information

General notes

The 12 or 16 key S.series keypads are specially designed for public environment applications, such as vending machines, ticket machines, payment terminals, telephones, access control systems and industrial machinery.

Keys and housing are built from chrome plated zinc alloy (Zamak). The S.series therefore has high resistance to impact and vandalism and is also sealed to IP 67.

Mounting

The keypad may be mounted from either the front or rear of a panel.

Front mounted keypads require a small cutout for the pin header connector on the back side of the S.series.

Rear mounted keypads are mounted through a rectangular cutout.

To ensure IP 67 sealing a gasket is supplied with the keypad and this is suitable for both forms of mounting.

Contacts

To ensure integrity of contacts and lower switch ratings, the contacts are gilded and external connection to the keypad is by means of a pin header on the back.

The electrical keypad circuit can be supplied in a choice of either matrix or common point configuration.

Keys

The metal anti pull-off keys are highly resistant to shock and fire.

Marking

Non-illuminated keys are engraved with the characters filled in black. Custom markings or symbols in different colours are available on request.

Illuminated keys are moulded with characters that are cutout then filled with a clear resistant resin for clear illumination.

Illumination

On illuminated versions the keys are individually lit with yellow or blue LED's which them especially suitable in poorly lit locations. Other LED colours are available on request.

NOTE

A load resistor may need to be connected by the customer in order to power the LEDs correctly.

Luminosity and wave length scattering caused by technologie used in the LED manufacturing processes may lead to visual differences in our products.

We reserve the right to modify technical data

All dimensions in mm

Keypad 12 keys, back mounting

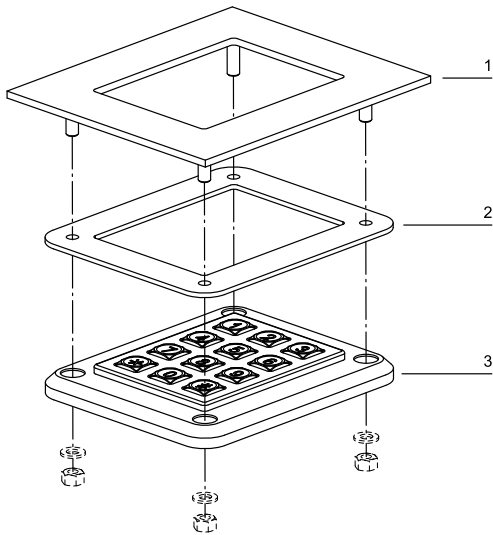

- 1 Front panel
- 2 Gasket
- 3 Keypad

Keypad 16 keys, front mounting

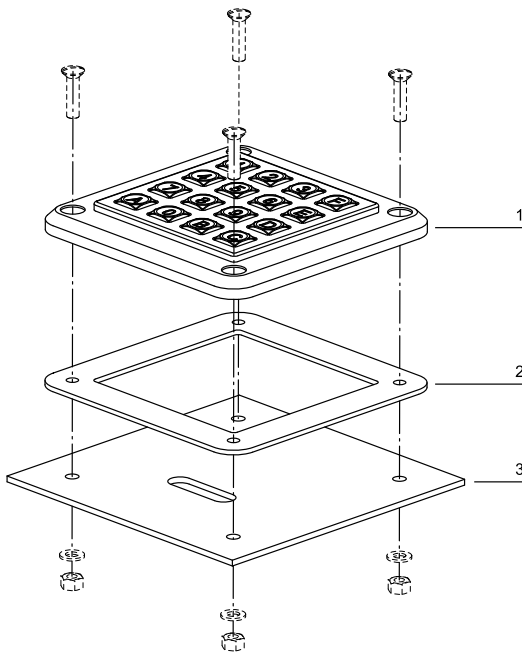

- 1 Keypad
- 2 Gasket
- 3 Front panel

Keypad



	Front protection	Terminals	Key cap	No. of keys	Marking	Illumination	Circuit	82 x 82 mm Typ-Nr.	63 x 82 mm Typ-Nr.	Component layout	Mounting dimensions	Technical drawing	IP
Keypad non-removable metal keys, vandal resistant	IP 67	PH	Zamak chromed	16	Hexadecimal	LED blue	P	S.16300.211		4	2	2	0.650
							M	S.16350.211		1	2	2	0.650
						LED yellow	P	S.16300.241		4	2	2	0.650
						M	S.16350.241		1	2	2	0.650	
					Hexadecimal black	without	P	S.16300.001		4	2	2	0.650
							M	S.16350.001		1	2	2	0.650
				12	Telephone	LED blue	P		S.12100.211	3	1	1	0.550
							M		S.12150.211	2	1	1	0.550
						LED yellow	P		S.12100.241	3	1	1	0.550
						M		S.12150.241	2	1	1	0.550	
					Telephone black	without	P		S.12100.001	3	1	1	0.550
							M		S.12150.001	2	1	1	0.550

Other options on request :

Custom colours, LED colours and markings

Terminals: PH = Pin header

Circuit: P = Common point, M = Matrix

Component layout from page 7, Mounting dimensions from page 9, Technical drawing from page 10

Keypad

Material

Keys

Zamak 5 with chrome finish

Housing

Zamak 5 with chrome finish

Back plate

Steel chromated

Contacts

Carbon pills
Carbon on Cu tracks

Climate resistance

as per EN IEC 60512-6
Damp heat 21 days
Dry heat 10 days, +85 °C
Saline mist 96 hours

Impact resistance

IK10 (20 J)

Approvals

Declaration of conformity

CE
RoHS

Mechanical characteristics

Actuating force

1 N ... 3 N

Actuating travel

1.5 mm ±0.3 mm

Rebound time

≤40 ms

Electrical characteristics

Operating voltage/-current

Nominal 5 V, 5 mA
Maximum voltage 24 V
Minimum voltage 0.5 V
Minimum current 0.1 mA

Illumination

Current consumption for single LED:
20 mA at 2.1 V (yellow and green)
20 mA at 1.9 V (red)
10 mA at 3.4 V (blue)

Isolation resistance

≥1000 MΩ at 100 VDC

Contact resistance

≤200 Ω

Electrical life

4 Million cycles of operation per key

Electrostatic breakdown value

5 kV

Electric strength

1500 V_{rms}, 50 Hz, 1 min., as per EN IEC 60512-2

Environmental conditions

Storage temperature

-30 °C ... +85 °C

Operating temperature

-25°C ... +85°C

Front protection

IP 67 as per IEC 60529, when mounted

Component layout

1 Keypad page 5

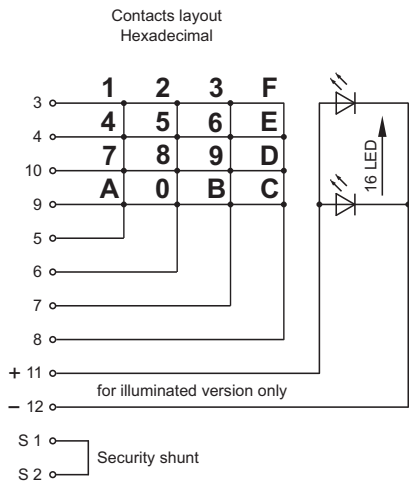

12 keys, Matrix, Hexadecimal

2 Keypad page 5

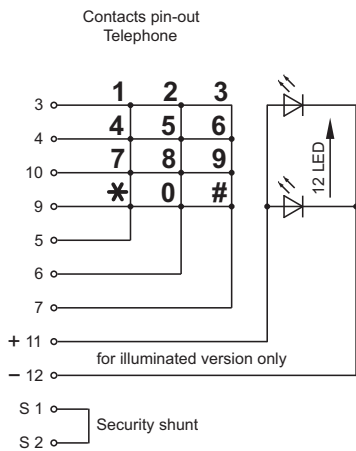

12 keys, Matrix, Telephone

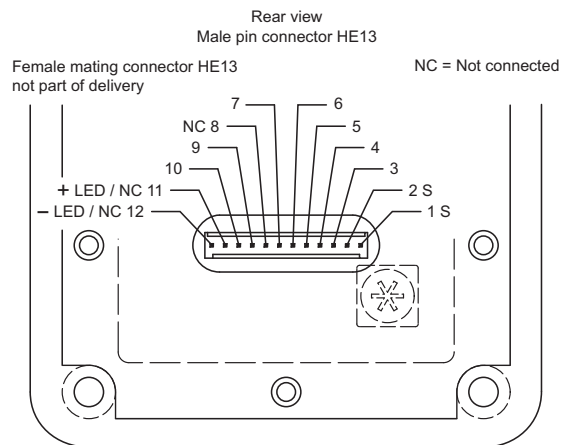
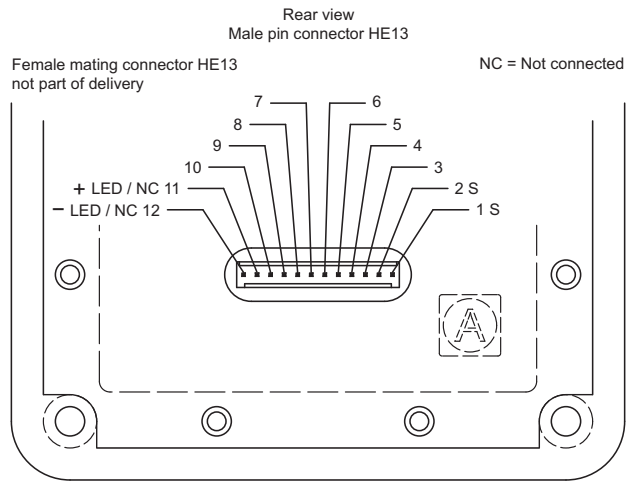

3 Keypad page 5

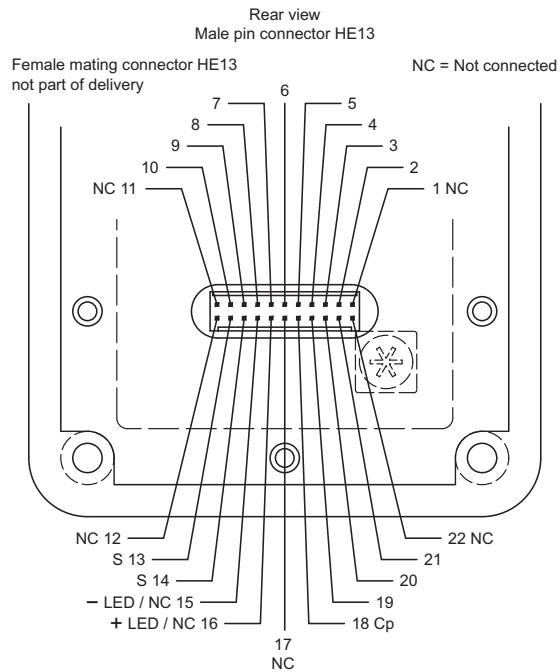
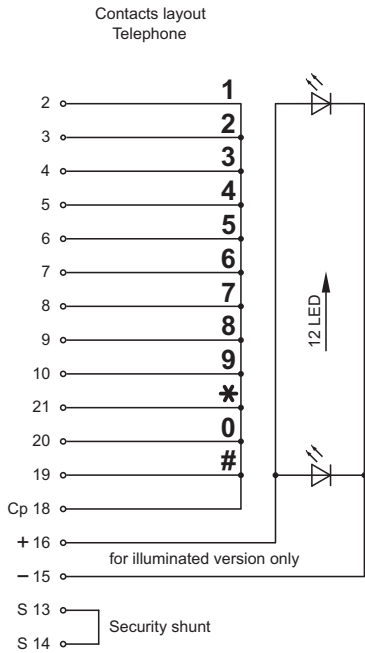

4 Keypad page 5

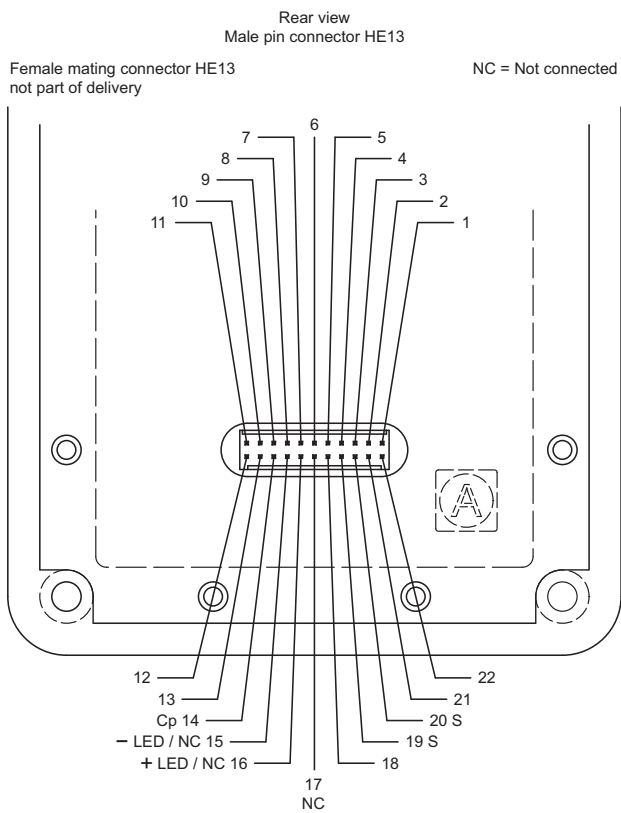
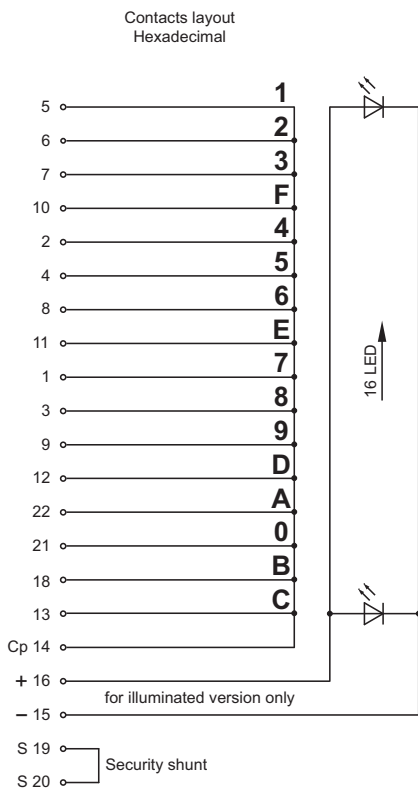

Mounting dimensions

1 Keypad page 5

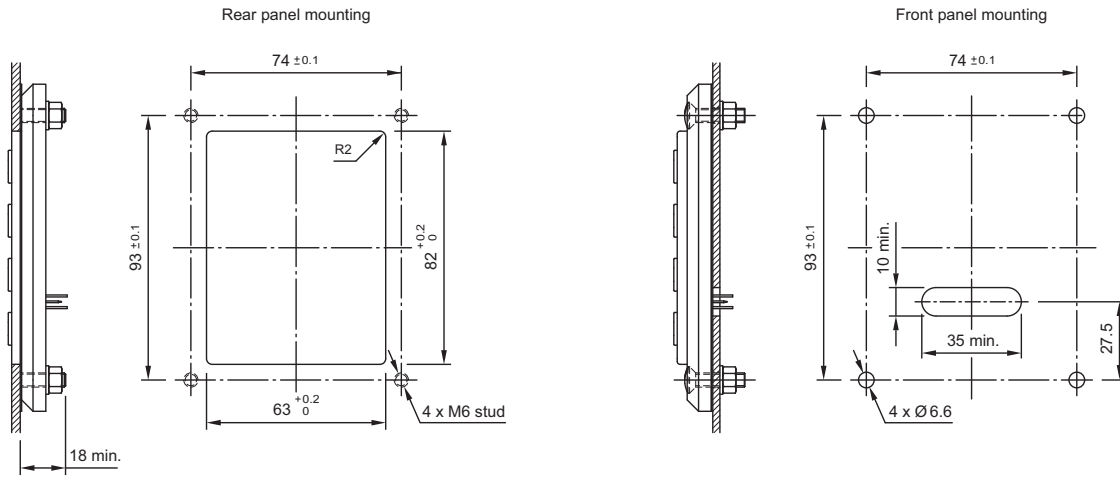

12 keys

2 Keypad page 5

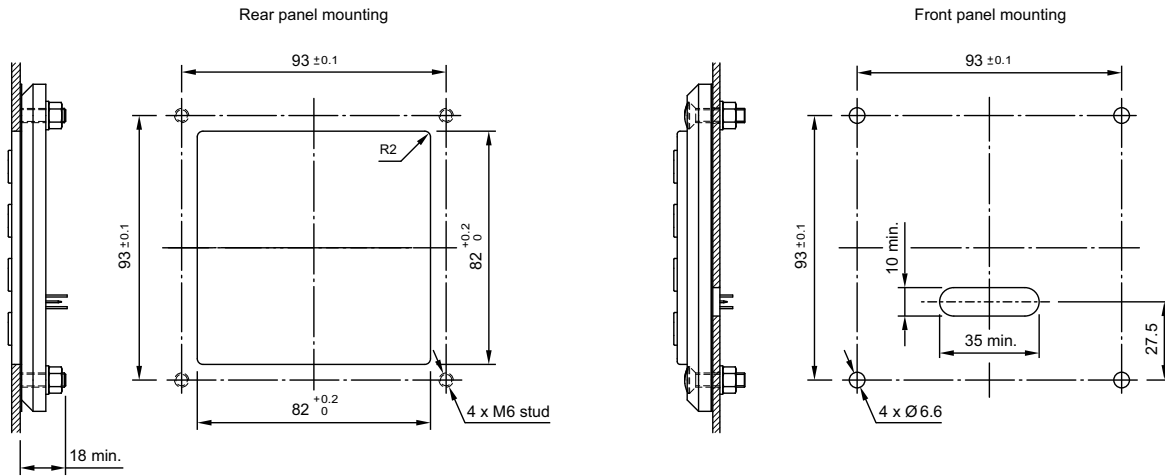

16 keys

Technical drawing

1 Keypad page 5

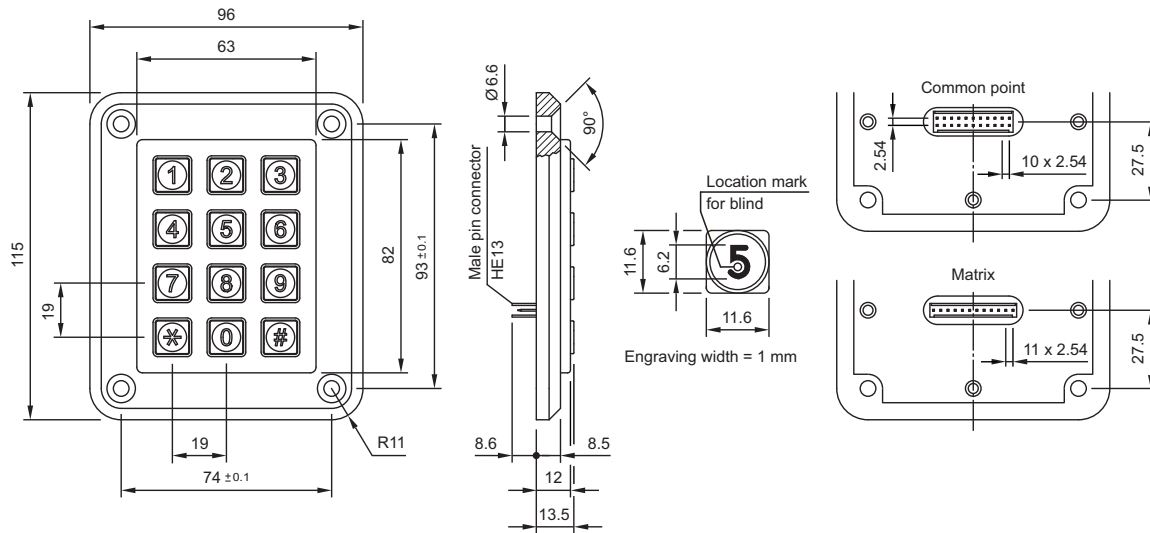

2 Keypad page 5

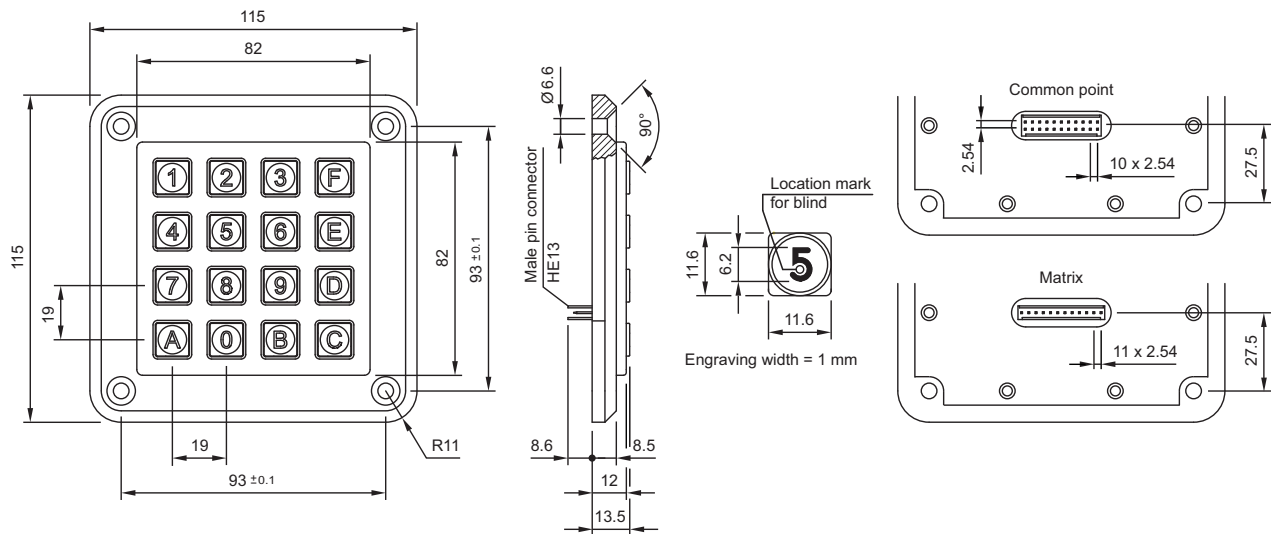

Index from Typ-Nr.

<u>Typ-Nr.</u>	<u>Page</u>	<u>Typ-Nr.</u>	<u>Page</u>	<u>Typ-Nr.</u>	<u>Page</u>
S.12100.001	5				
S.12100.211	5				
S.12100.241	5				
S.12150.001	5				
S.12150.211	5				
S.12150.241	5				
S.16300.001	5				
S.16300.211	5				
S.16300.241	5				
S.16350.001	5				
S.16350.211	5				
S.16350.241	5				