

Customer :

No. SW065067A

ALPS EUROPE DISTRIBUTION

Date : 2006 - 07 - 20

Attention :

Your ref. No. :

Your Part No. : SPUJ193900

SPECIFICATION

ALPS' ;

MODEL : SPUJ193900

Spec. No. : SPUJ-S-501

Sample No. : F3289725M

RECEIPT STATUS

RECEIVED

By Date

Signature

Name

Title

ALPS[®]
ALPS ELECTRIC CO., LTD.

DSG' D K. Tomita

APP' D K. ITO
ENG. DEPT. DIVISION

Sales

Head Office
1-7, Yukigaya-otsuka-cho, Ota-ku, Tokyo. 145-8501 Japan
Phone. +81(3)3726-1211

SPUJ-S-501	SPUJ PRODUCT SPECIFICATIONS	⑤
------------	-----------------------------	---

1. General
 - 1.1 Application This specification is applied to low current circuit (Secondary circuit) push switch used for electronic equipment.
 - 1.2 Operating temperature range : -10 ~ 60°C Δ Storage temperature range -10 ~ 60°C
 - 1.3 Test conditions The standard test conditions shall be 5~35°C in temperature, 45~85% RH and 86~106kPa (~~860~1060mbar~~) Δ in atmospheric pressure. Should any doubt arise in judgement, tests shall be conducted at 20±2°C, 65±5% RH and 86~106kPa (~~860~1060mbar~~) Δ
2. Appearance, construction and dimensions
 - 2.1 Appearance Switch shall have good finishing, and shall have no rust, crack or plating failures.
 - 2.2 Construction and dimensions Per individual product drawing
 - 2.3 Markings Per individual product drawing
3. Rating 30 V DC 0.1 A (Resistive load)
4. Electrical performance



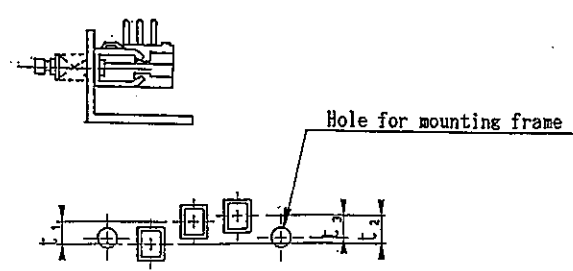

Items	Test conditions	Criterion
4.1 Contact resistance	Shall be measured at 1kHz±200Hz (20mV MAX , 50mA MAX) or 1A, 5V DC by voltage drop method.	20 mΩ MAX
4.2 Insulation resistance	Test voltage : 500 V DC, measured after 1 minute±5 seconds. Applied position : Between all terminals Between terminals and ground (frame)	100 MΩ MIN
4.3 Voltage proof	Test voltage : 500 V AC (50~60Hz, cut-off current 2 mA) Applied position : Between all terminals Between terminals and ground (frame)	No dielectric breakdown shall occur.
4.4 Capacitance	Shall be measured at 1MHz ± 10kHz Between all terminals Between terminals and ground (frame) Between all circuits	1.5 pF MAX
4.5 Changeover timing		As per individual product drawing.

Items	Test conditions	Criterion
5.1 Operating force	A static load shall be applied to the tip of actuator in operating direction.	As per individual product drawing.
5.2 Terminal strength	A static load of <u>5 N</u> (5.1 kgf) Δ shall be applied to the tip of terminal in a desired direction for 1 minute. The number of test shall be once per terminal.	Shall be free from terminal looseness and damage and breakage of terminal holding portion. Terminals may be bent after test, electrical performance requirement specified in item 4 shall be satisfied.
5.3 Mounting strength of thread portion	Thread shall be mounted at <u>0.6 N·m</u> (6.12 kgf·cm) Δ by normal mounting method.	Shall be free from damage of thread portion. (Applied to frame with screw.)
5.4 Control strength	(1) A static load of <u>50 N</u> (5.1 kgf) Δ shall be applied in the operating direction of actuator for 15 seconds. (2) A static load of <u>50 N</u> (5.1 kgf) Δ shall be applied in the pull direction of actuator for 15 seconds. (For construction with lock, the test shall be conducted at the condition of lock released.) (3) A static load of <u>10 N</u> (1.02 kgf) Δ shall be applied to the vertical direction of operation at the tip of actuator for 15 seconds.	Shall be free from pronounced wobble and mechanical abnormalities.
5.4.2 Lock holding strength of actuator (Applied to the switch with lock mechanism)	(1) A static load of <u>10 N</u> (1.02 kgf) Δ shall be applied in the pull direction at the condition of locking actuator.	Lock shall not be dislocated. Shall be free from pronounced wobble and abnormalities in operation.
5.5 Wobble of actuator	Run-out(P-P) shall be measured by applying a static load of 1N (102 gf) in the vertical direction of operation at the tip of actuator.	P-P : 0.8 mm MAX (1.8 mm MAX, without frame.)
5.6 Row of actuator (Applied to multipul-key push switch)	Switch shall be mounted as shown. Difference of sides shall be measured. 	Difference between actuators t ₁ = Within <u>0.5</u> mm Maximum difference of actuator t ₂ = Within <u>0.8</u> mm Difference between mounting hole and actuator t ₃ = Within <u>0.5</u> mm

1/5	⑤	Nov. 1, 2001	F.Y	F.Y	M.H	APPD.	CHKD.	DSGD.	TITLE
15.75.75	⑤	13	K.I	K.I	F.Y	M	S.	Jun. 30 '93	DRAWING NO.
PAGE	SYMB	DATE	APPD	CHKD	DSGD	Kitae	Takahashi	H. Yamaguchi	(1/5)

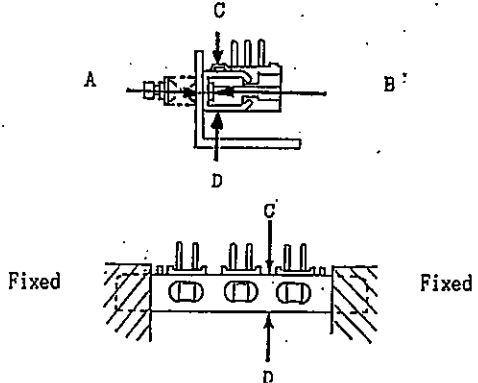
SPUJ-S-501

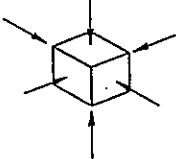
SPUJ PRODUCT SPECIFICATIONS

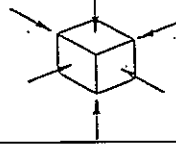
Items	Test conditions	Criterion									
5.7 Mounting frame strength (Applied to multi-pul-key push switch)	<p>Both ends of mounting frame shall be secured. A static load of 30N 300g shall be applied to the center of mounting frame in A, B, C and D directions each 15 seconds.</p> 	Warp on mounting frame shall be 0.5mm max. Shall be free from abnormalities in operation.									
5.8 Vibration	<p>Switch shall be secured to a testing machine by a regular mounting device and method.</p> <ol style="list-style-type: none"> (1) Vibration frequency range : 10~55Hz (2) Total amplitude : 1.5mm (3) Sweep ratio : 10-55-10(Hz) Approx. 1 minute (4) Method of changing the sweep vibration frequency : Logarithmic or linear (5) Direction of vibration : Three vertical directions including actuator. (6) Time : 2 hours each (6 hours in total) 	<p>Contact resistance (Item 4.1) : <u>20</u> mΩ MAX Insulation resistance (Item 4.2) : <u>100</u> MΩ MIN Voltage proof (Item 4.3) : Apply <u>500</u> V AC for 1 minute. No dielectric breakdown shall occur. Operating force (Item 5.1) : Within ± 30 % of specified value. No abnormalities shall be recognized in appearance and construction.</p>									
5.9 Mechanical shock 5.9.1 Mechanical shock	<p>Switch shall be measured after following test.</p> <ol style="list-style-type: none"> (1) Mounting method : Normal mounting method (2) Acceleration : <u>490</u>m/s² 500  (3) Duration : 11ms (4) Test direction : 6 directions (5) Number of shock : 3 times per direction (18 times in total) 	<p>Contact resistance (Item 4.1) : <u>20</u> mΩ MAX Operating force (Item 5.1) : Within ± 30 % of specified value. Shall be free from mechanical abnormalities. (Dislocation of lock of actuator shall not be regarded as abnormalities.)</p>									
5.9.2 Lock holding shock (Applied to the switch with lock mechanism.)	<p>Switch shall be conducted at the condition of locking actuator.</p> <ol style="list-style-type: none"> (1) Acceleration : <u>147</u>m/s² 150  (2) Duration : <u>11</u> ms (3) Test direction : 6 directions (4) Number of shock : 3 times per direction (18 times in total) 	Lock of actuator shall not be dislocated. Shall be free from abnormalities in operation.									
5.10 Solderability	<p>Switch shall be checked after following test.</p> <ol style="list-style-type: none"> (1) Solder : H63A (JIS Z 3282) (2) Flux : Rosin flux (JIS K 5902) having a nominal composition of 25% solids by weight of water white rosin in methyl alcohol (JIS K 1501) solution. (3) Soldering temperature : 230±5°C Immersing time : 3±0.5 s Flux immersing time shall be 5~10 seconds in normal temperature. (4) Immersion depth : Immersion depth shall be at copper plating portion for P.C.B. terminal after mounting. Thickness of P.C. board : 1.6 mm 	More than 90% of immersed part shall be covered with solder.									
5.11 Soldering heat resistance	<p>Switch shall be measured after following test.</p> <ol style="list-style-type: none"> (1) Solder : H63A (JIS Z 3282) (2) Flux : Rosin flux (JIS K 5902) having a nominal composition of 10% solids by weight of water white rosin in methyl alcohol (JIS K 1501) solution. (3) Temperature and immersing time <table border="1" data-bbox="526 1948 1069 2038"> <thead> <tr> <th></th> <th>Temperature (°C)</th> <th>Time (s)</th> </tr> </thead> <tbody> <tr> <td>Dip soldering</td> <td>260±5</td> <td>5±1</td> </tr> <tr> <td>Manual soldering</td> <td>300±10</td> <td>3⁺¹/₀</td> </tr> </tbody> </table>		Temperature (°C)	Time (s)	Dip soldering	260±5	5±1	Manual soldering	300±10	3 ⁺¹ / ₀	No abnormalities shall be recognized in appearance. The electrical performance requirements specified in item 4 shall be satisfied.
	Temperature (°C)	Time (s)									
Dip soldering	260±5	5±1									
Manual soldering	300±10	3 ⁺¹ / ₀									

APPD.	CHKD.	DSGD.	TITLE
<i>M.</i>	<i>S.</i>	Jun, 30 '93	DRAWING NO.
<i>K. Iwano</i>	<i>T. Takahashi</i>	<i>H. Yamaguchi</i>	(2/5)

SPUJ-S-501		SPUJ PRODUCT SPECIFICATIONS						
Items	Test conditions				Criterion			
	(4) Immersion depth : Immersion depth shall be at copper plating portion for P.C.B. terminal after mounting. Thickness of P.C. board (Single sided copper clad P.C.B.) : 1.6mm							
5.12	Resistance to flux (Applied to the switch for P.C. board)	Switch shall be checked after following test. (1) Equipment : Auto-dip chamber (2) Solder : H63A (JIS Z 3282) (3) Flux : Rosin flux (JIS K 5902) having a nominal composition of 25% solids by weight of water white rosin in methyl alcohol (JIS K 1501) solution. (4) Temperature : 260±5°C (5) Immersing time : 5±1 s (6) Immersion depth : Immersion depth shall be at copper plating portion for P.C.B. terminal after mounting. Thickness of P.C. board : 1.6 mm				Flux shall not be risen up to contact. Shall be free from abnormalities in operation.		
6. Durability								
Items	Test conditions				Criterion			
6.1	Operating life without load	Switch shall be operated 10,000 cycles at 15~20 cycles/minute without load.				Contact resistance (Item 4.1) : <u>40</u> mΩ MAX Insulation resistance (Item 4.2) : <u>10</u> MΩ MIN Voltage proof (Item 4.3) : Apply <u>500</u> V AC for 1 minute. No dielectric breakdown shall occur. Operating force (Item 5.1) : Within $\pm \frac{10}{30}$ % of specified value. No abnormalities shall be recognized in appearance and construction.		
6.2	Operating life with load	Switch shall be operated 10,000 cycles at 15~20 cycles/minute with <u>30</u> V DC <u>0.1</u> A. (Resistive load)				Contact resistance (Item 4.1) : <u>40</u> mΩ MAX Insulation resistance (Item 4.2) : <u>10</u> MΩ MIN. Voltage proof (Item 4.3) : Apply <u>500</u> V AC for 1 minute. No dielectric breakdown shall occur. Operating force (Item 5.1) : Within $\pm \frac{10}{30}$ % of specified value. No abnormalities shall be recognized in appearance and construction.		
7. Weather proof								
Items	Test conditions				Criterion			
7.1	Cold proof	After testing at -20±2°C for 96 hours, the switch shall be allowed to stand under normal temperature and humidity conditions for 1 hour, and then measurement shall be made within 1 hour. Water drops shall be removed.				Contact resistance (Item 4.1) : <u>40</u> mΩ MAX Insulation resistance (Item 4.2) : <u>10</u> MΩ MIN Voltage proof (Item 4.3) : Apply <u>500</u> V AC for 1 minute. No dielectric breakdown shall occur. Operating force (Item 5.1) : Within $\pm \frac{10}{30}$ % of specified value. No abnormalities shall be recognized in appearance and construction.		
7.2	Dry heat	After testing at 85±2°C for 96 hours, the switch shall be allowed to stand under normal temperature and humidity conditions for 1 hour, and then measurement shall be made within 1 hour.				Contact resistance (Item 4.1) : <u>40</u> mΩ MAX Insulation resistance (Item 4.2) : <u>10</u> MΩ MIN Voltage proof (Item 4.3) : Apply <u>500</u> V AC for 1 minute. No dielectric breakdown shall occur. Operating force (Item 5.1) : Within $\pm \frac{10}{30}$ % of specified value. No abnormalities shall be recognized in appearance and construction.		
					APPD.	CHKD.	DSGD.	TITLE
					<i>M</i>	<i>S</i>	<i>Jun. 30 '93</i>	DRAWING NO.
					<i>K. Sato</i>	<i>Takahashi</i>	<i>H. Yamaguchi</i>	(3/5)
PAGE	SYMB	DATE	APPD	CHKD	DSGD			

SPUJ-S-501	SPUJ PRODUCT SPECIFICATIONS
------------	-----------------------------

	Items	Test conditions	Criterion
7.3	Damp heat	After testing at $40\pm 2^\circ\text{C}$ and $90\sim 95\%RH$ for 96 hours, the switch shall be allowed to stand under normal temperature and humidity conditions for 1 hour, and measurement shall be made within 1 hour after that. Water drops shall be removed.	Contact resistance (Item 4.1) : <u>40</u> mΩ MAX Insulation resistance (Item 4.2) : <u>10</u> MΩ MIN Voltage proof (Item 4.3) : Apply <u>500</u> V AC for 1 minute. No dielectric breakdown shall occur. Operating force (Item 5.1) : Within <u>± 30</u> % of specified value. No abnormalities shall be recognized in appearance and construction.
7.4	Salt mist	Switch shall be checked after following test. (1) Temperature : $35\pm 2^\circ\text{C}$ (2) Salt solution : $5\pm 1\%$ (Solids by weight) (3) Duration : 24 ± 1 h After the test, salt deposit shall be removed in running water.	No remarkable corrosion shall be recognized in metal part.
7.5	Temperature cycling	After 5 cycles of following conditions, the switch shall be allowed to stand under normal temperature and humidity conditions for 1 hour, and measurement shall be made within 1 hour after that. Water drops shall be removed. <div style="text-align: center;"> <p style="font-size: small;">70±2°C ----- Normal temperature ----- ----- -25±3°C ----- 30 min 30 min 10~15 min 10~15 min ----- 1 cycle</p> </div>	Contact resistance (Item 4.1) : <u>40</u> mΩ MAX Insulation resistance (Item 4.2) : <u>10</u> MΩ MIN Voltage proof (Item 4.3) : Apply <u>500</u> V AC for 1 minute. No dielectric breakdown shall occur. Operating force (Item 5.1) : Within <u>± 30</u> % of specified value. No abnormalities shall be recognized in appearance and construction.
7.6	Damp heat with load (Silver migration)	DC voltage 1.5 times as much as rated voltage shall be applied continuously between adjacent terminal at $60\pm 2^\circ\text{C}$ and $90\sim 95\%RH$. After 500 hours testing, switch shall be allowed to stand under normal temperature and humidity condition for 1 hour, and measurement shall be made within 1 hour after that. Water drops shall be removed.	Insulation resistance (50V DC) : <u>10</u> MΩ min. Voltage proof : Apply 100V AC for 1 minute. No dielectric breakdown shall occur.

8. Mechanical performance

	Items	Test conditions	Criterion
8.1	Preventive strength of simultaneous locking (Applied to the switch with simultaneous locking prevention cam.)	A load of <u>20N(2044gf)</u> shall be applied between adjacent keys for 15 sec. as follows. <div style="text-align: center;"> </div>	2 keys shall not be locked at the same time.

Precaution in use

1. Note that if the load is applied to the terminals during soldering they might suffer deformation and defects in electrical performance.
2. Use of water-soluble soldering flux shall be avoided because it may cause corrosion of the switch.
3. The knob should be mounted or demounted after single-lock releasing.
If attempted under single locked condition, the single-acting mechanism may be damaged.

										APPD. <i>M.</i>	CHKD. <i>S.</i>	DSGD. <i>Jan. 30 '93</i>	TITLE
PAGE	SYMB	DATE	APPD	CHKD	DSGD	<i>K. Ito</i>	<i>Takahashi</i>	<i>H. Yamaguchi</i>	DRAWING NO.				

4. Flux flow

If too much flux is applied to the PCB it may penetrate into the switch and inhibit subsequent operation.



Flux may flow into the switch mount as indicated by

Printed circuit board mounting hole diagram.
(±0.05 tolerance unless otherwise specified)

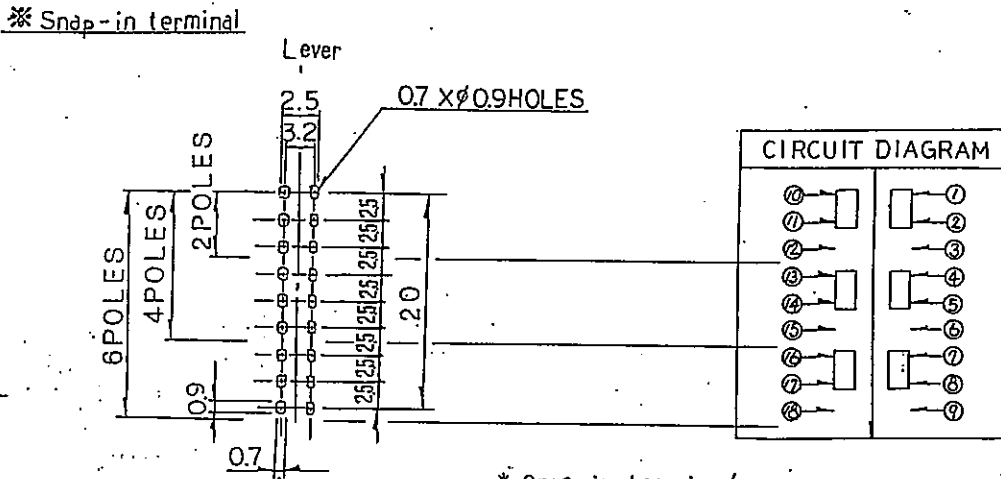
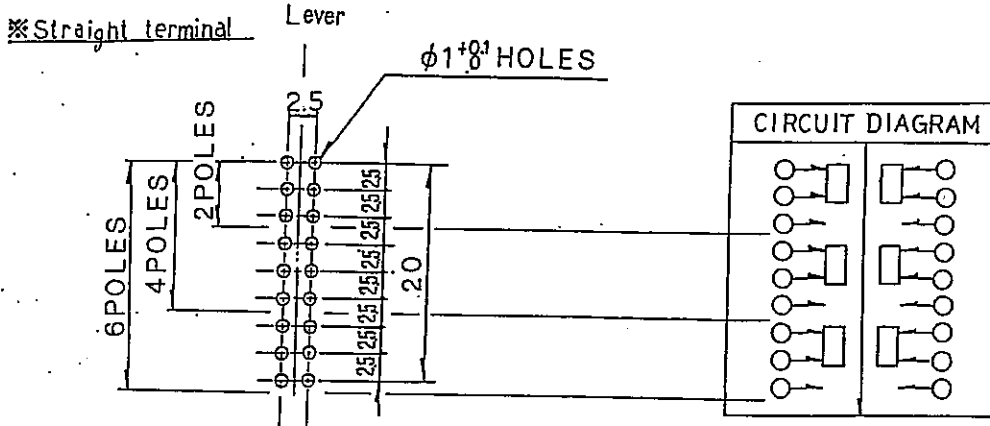

Snap-in terminal detail.

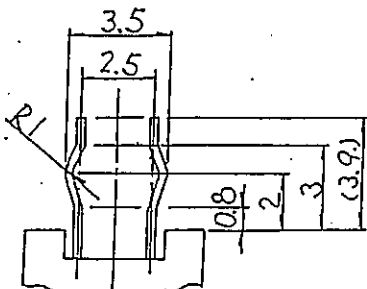

* Snap-in terminal

- 2 POLES: TERMINAL NO. (1) (2) (3) (10) (11) (12)
- 4 POLES: TERMINAL NO. (2) (5) (11) (14)
- 6 POLES: TERMINAL NO. (2) (5) (8) (11) (14) (17)

5. Soldering should be performed after single lock released. If attempted under single locked condition, the single-acting mechanism may be deformed by soldering heat.

APPD.	CHKD.	DSGD.	TITLE
M.	S.	Jan, 30 '93	
DESCRIPTION	PAGE	SYMB	DATE
SPUJ-S-501	(A)	Jan 27	T.N
APPD	CHKD	DSGD	
K. Iwano	S. Takahashi	H. Yamaguchi	
DRAWING NO.			(5/5)



BACK GROUND
S I 単位化

5 : SHORTING (ショート)
NS : NON-SHORTING (ノンショート)
ST : STRAIGHT (ストレート)
SP : SNAP-IN (スナップイン)

DETAIL AS PER PRODUCT SPECIFICATIONS.
(詳細は製品仕様書による)

⑥ DETAIL (詳細 X2/1)

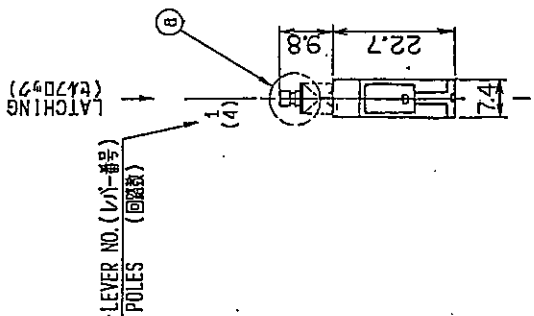
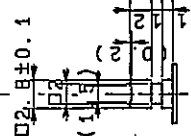

LEVER NO. (レバー番号)
POLES (回線数)

TOTAL TRAVEL (全移動量)

TRAVEL (移動量)

LATCHING (止め70%)	2	3
TOTAL TRAVEL		

P. C BOARD MOUNTING FACE
(プリント基板取付面)

TOLERANCES UNLESS OTHERWISE SPEC.		TOLERANCES	
BASIC DIMENSIONS	UP TO 4	± 0.2	
	OVER 4 UP TO 16	± 0.3	
	OVER 16 UP TO 63	± 0.4	
	ABOVE 63 TO 250	± 0.5	
	ABOVE 250	± 0.7	
ANGULAR DIMENSIONS	$\pm 3^\circ$		

UNIT	mm
SCALE	1/1
MODEL NO. (機種)	SPUJ193900
TITLE	PRODUCT DRAWING (製品図)
DOCUMENT NO.	
CHKD.	May 19 38
DSGD.	May 19 38
APPD.	May 19 38
DESIGNER	H. Yoshizawa
DRAWN	K. I. C. I. F. Y.
DATE	May 20 1938
ZONE	STAB
DATE	
APPD.	CHKD.
DSGD.	DSGD.