

1 2 3 4 5

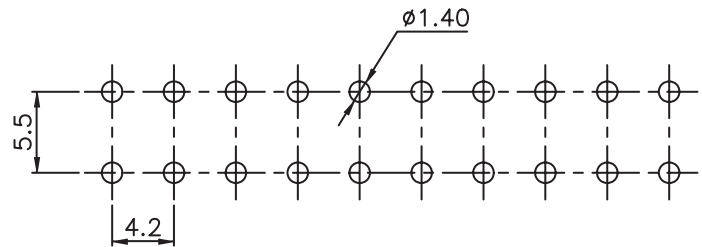
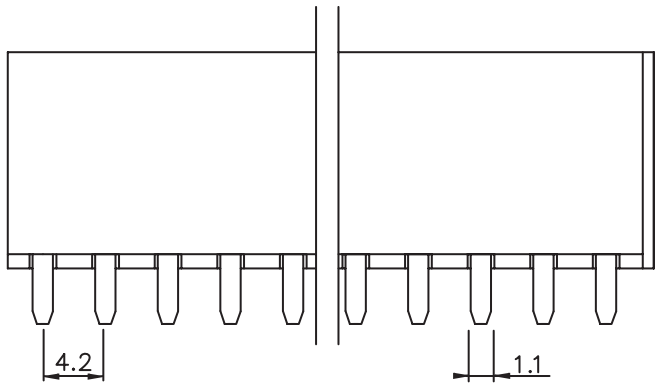
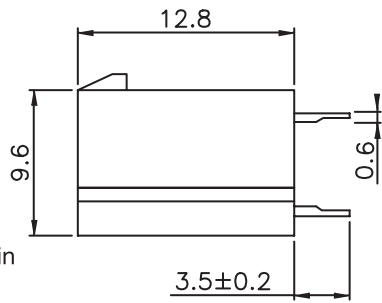
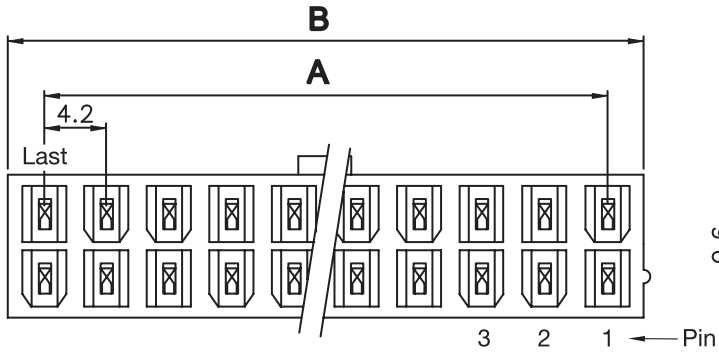

PCB LAYOUT - COMPONENT VIEW

TECHNICAL CHARACTERISTICS

MATERIAL
 INSULATOR: NYLON 66
 FLAMABILITY RATING: UL94-V0
 COLOR: WHITE
 CONTACT MATERIAL: TIN OVER NICKEL
 CONTACT TYPE: STAMPED
 CONTACT PLATING: TIN
 QUALITY CLASS: 25 MATING CYCLES
 PITCH: 4.20MM

ENVIRONMENTAL
 OPERATING TEMPERATURE: -40 UP TO 105°C
 COMPLIANCE: LEAD FREE AND ROHS

ELECTRICAL
 CURRENT RATING: 6 TO 9A

| | | | | |
|---------------|-------|-------|--------|-------|
| NB CIRCUITS □ | 2-3 □ | 4-6 □ | 7-10 □ | 12-24 |
| AMPERES □ | 9 □ | 8 □ | 7 □ | 6 |

WORKING VOLTAGE: 600V AC
 INSULATOR RESISTANCE: >1000 MOHM
 DIELECTRIC WITHSTANDING VOLTAGE: 1500V AC/MN
 CONTACT RESISTANCE: 20 mOHM MAX

STANDARD
 Ⓜ CERTIFIED: E323964 / MODEL NUMBER 649-2S

SOLDERING
 WAVE PROCESS ONLY

PACKAGING
 TRAY

DIMENSION
 A = 4.20 x (NB. PIN / 2 - 1)
 B = 4.20 x (NB. PIN / 2) + 1.30

| | | | |
|----------------|-----------|-------------------|----|
| RoHS Compliant | | | |
| G | | | |
| F | | | |
| E | 04-OCT-11 | UL | GG |
| D | 10-AUG-11 | CONTACT | GG |
| C | 18-NOV-09 | STANDARD | JP |
| B | 23-AVR-09 | PACKAGING | JC |
| A | 12-NOV-08 | UL 94-V0 & PINING | JP |
| REV | DATE | FILE | BY |

| | |
|--------------|--|
| PROJECTION: | |
| APPROVAL: RJ | |

| |
|-------------------|
| GENERAL TOLERANCE |
| .X = +/- 0.2 |
| .XX = +/- 0.15 |
| UNIT: MM |
| SCALE: |
| SHEET: 1/2 |
| DRAW: PEARL |

| | | |
|--|---------------------------------------------------|-------------------|
| | DESCRIPTION: 4.20MM MALE DUAL ROW VERTICAL HEADER | SIZE A4 |
| | WERI PART NO: 649 0xx 211 22 | |

A
B
C
D

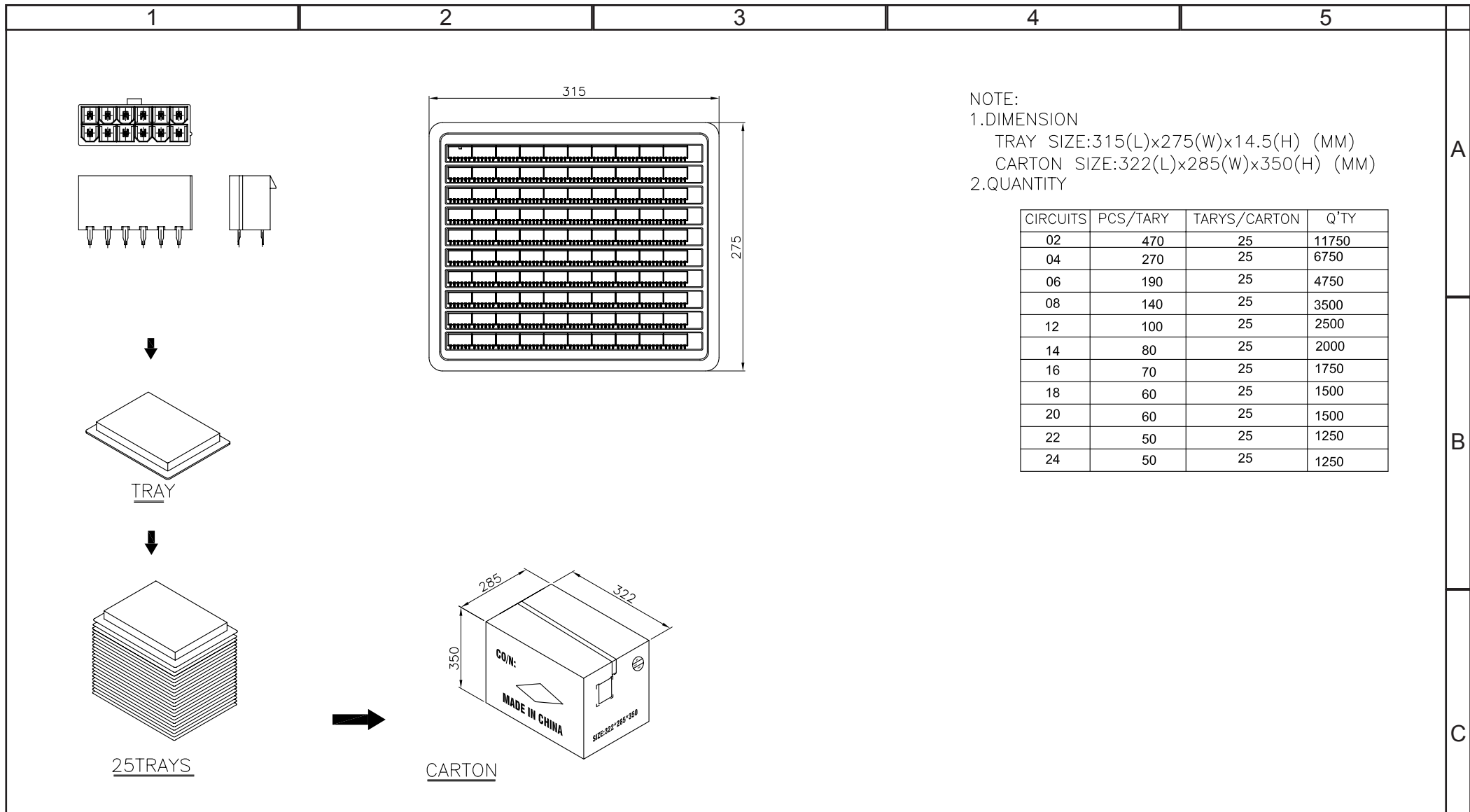

| | | | | | | | | |
|----------------|------|------|----|-----------------|-----------------------------------------------------|--|---------------------------------------------------|-------------------|
| RoHS Compliant | | | | PROJECTION: | GENERAL TOLERANCE .X = +/- 0.2 .XX = +/- 0.15 | | DESCRIPTION: 4.20MM MALE DUAL ROW VERTICAL HEADER | SIZE A4 |
| G | | | | | | | | |
| F | | | | | SCALE: | | | |
| E | | | | | SHEET: 2/2 | | | |
| D | | | | | DRAW: PEARL | | | |
| C | | | | | | | | |
| B | | | | | | | | |
| A | | | | | | | | |
| REV | DATE | FILE | BY | | | | | |