

PCB LAYOUT
COMPONENT VIEW

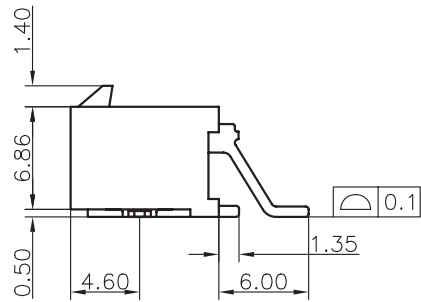

TECHNICAL CHARACTERISTICS

MATERIAL
 INSULATOR: NYLON 6T
 FLAMABILITY RATING: UL94-V0
 COLOR: BLACK
 CONTACT MATERIAL: COPPER ALLOY
 CONTACT TYPE: STAMPED
 CONTACT PLATING: TIN
 QUALITY CLASS: 25 MATING CYCLES
 PITCH: 3.00MM

ENVIRONMENTAL
 OPERATING TEMPERATURE: -25 UP TO 105°C
 COMPLIANCE: LEAD FREE AND ROHS

ELECTRICAL
 CURRENT RATING: 5A
 WORKING VOLTAGE: 250V AC
 INSULATOR RESISTANCE: >1000 MOHM
 DIELECTRIC WITHSTANDING VOLTAGE: 1500V AC/MN
 CONTACT RESISTANCE: 10 mOHM MAX

STANDARD
 CERTIFIED: E323964 / MODEL NUMBER 662-R

SOLDERING
 REFLOW PROCESS ONLY

PACKAGING
 TRAY

DIMENSION
 A = 3.00 x (NB. PIN / 2 - 1)
 B = 3.00 x (NB. PIN / 2 + 1) + 0.70

RoHS Compliant			
G			
F			
E	22-FEB-12	DESCRIPTION	GG
D	18-NOV-09	STANDARD	JP
C	27-JUL-09	REAR PIN	JP
B	23-AVR-09	PACKAGING	JC
A	25-FEB-05	PDF DRAW	JP
REV	DATE	FILE	BY

PROJECTION:	
APPROVAL: RJ	

GENERAL TOLERANCE	
.X = +/- 0.2	
.XX = +/- 0.15	
UNIT: MM	
SCALE:	
SHEET: 1/2	
DRAW: PEARL	

DESCRIPTION: 3.00MM MALE DUAL ROW SMT RIGHT ANGLE HEADER SMT SOLDER TAB	
WERI PART NO: 662 0xx 231 722	

SIZE	
A4	

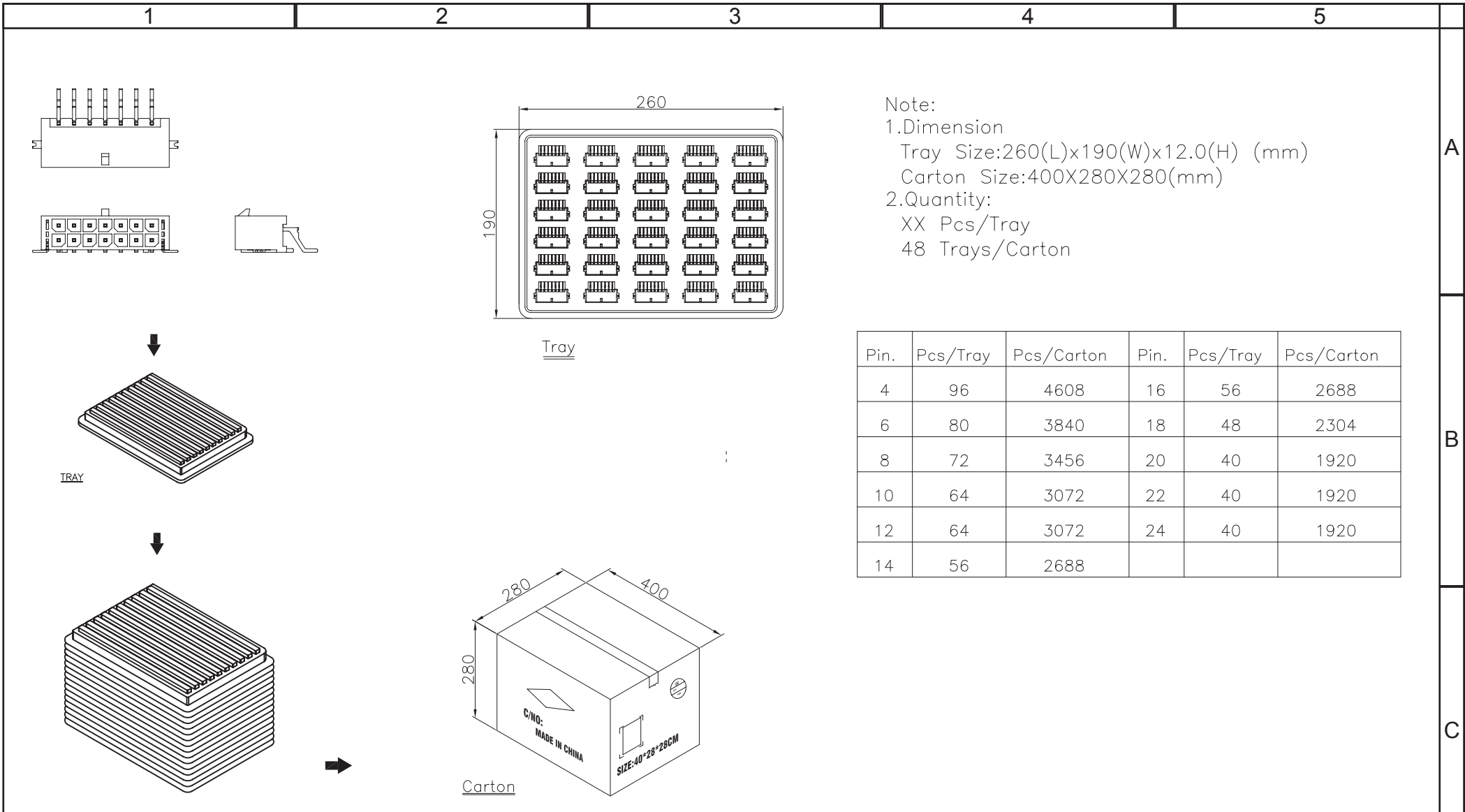

Note:
 1.Dimension
 Tray Size:260(L)x190(W)x12.0(H) (mm)
 Carton Size:400X280X280(mm)
 2.Quantity:
 XX Pcs/Tray
 48 Trays/Carton

Pin.	Pcs/Tray	Pcs/Carton	Pin.	Pcs/Tray	Pcs/Carton
4	96	4608	16	56	2688
6	80	3840	18	48	2304
8	72	3456	20	40	1920
10	64	3072	22	40	1920
12	64	3072	24	40	1920
14	56	2688			

RoHS Compliant				PROJECTION: 	GENERAL TOLERANCE .X = +/- 0.2 .XX = +/- 0.15		DESCRIPTION: 3.00MM MALE DUAL ROW SMT RIGHT ANGLE HEADER SMT SOLDER TAB	SIZE A4
G								
F					SCALE:			
E					SHEET: 2/2			
D					DRAW: PEARL			
C								
B								
A								
REV	DATE	FILE	BY					