

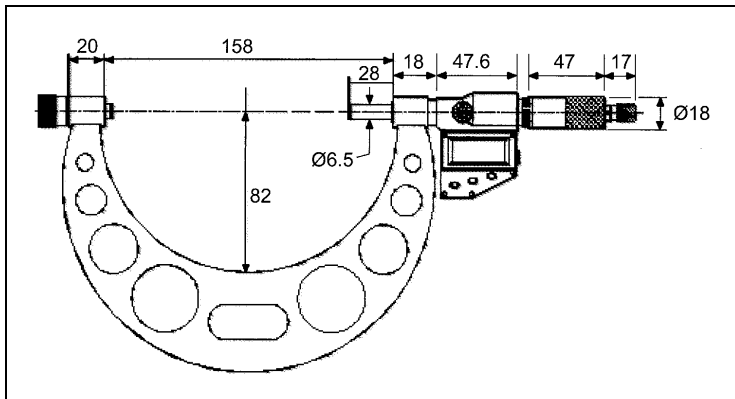

Protection: IP 54 Splash Proof
 DIN 863/1
 Clear LCD Display
 Metric/Inch Conversion
 Relative & Absolute Modes
 Resolution 0.001mm/0.0005"
 Tungsten Carbide Anvils
 Ratchet Stop
 Spindle Lock
 Setting Rods
 Supplied in fitted case



Code	Range mm/Inch	A mm	L mm	Accuracy mm
50-450-150	0-150	82	158	0.003

Power: 1 x SR44: 1.5V battery

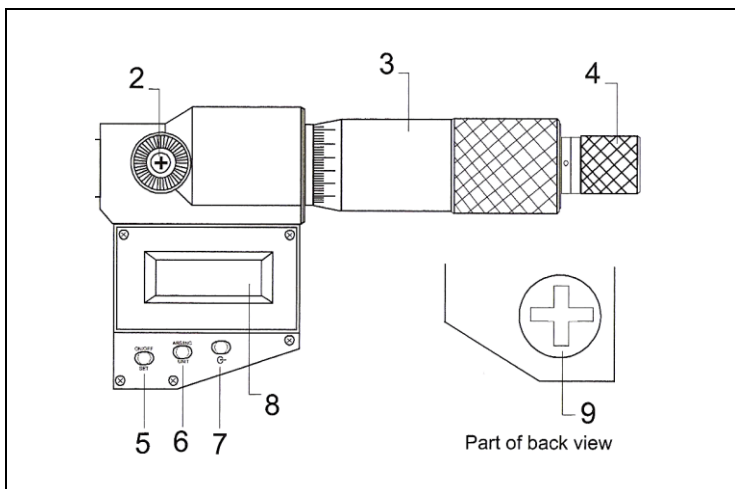

- 2 Locking Device
- 3 Thimble
- 4 Ratchet Stop
- 5 ON/OFF & SET Button
- 6 ABS/INC & UNIT Button
- 7 Data Output button (not available)
- 8 Battery cover

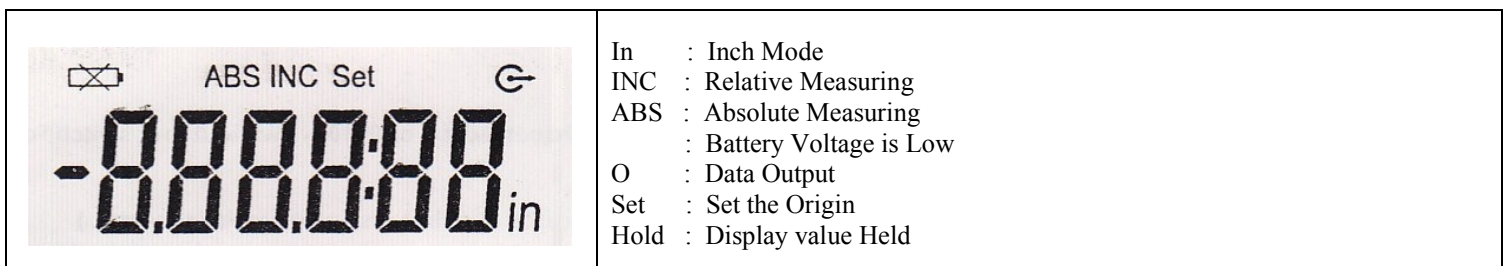
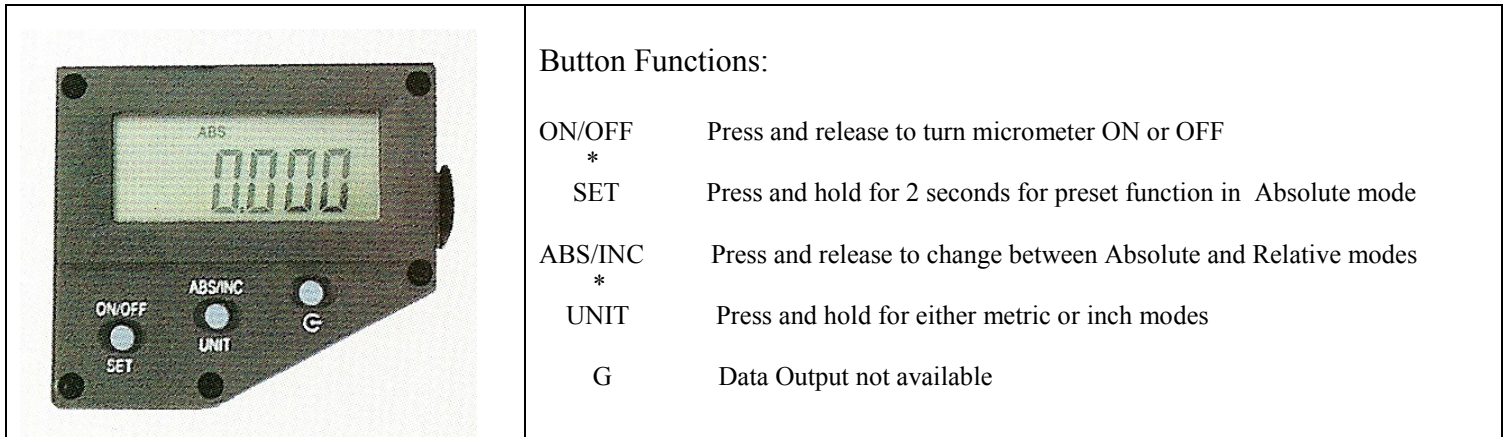

Setting Instructions:

Fit the required Extension Rod, place the correct Setting Rod between the micrometer anvils and close the spindle onto the setting rod using the ratchet stop to make the final adjustment. Proceed as below

- 1: Press and release ON/OFF button to switch on display
- 2: Press and hold UNIT button to select either Metric or Inch resolution
- 3: Press and release ABS/INC button to obtain ABS in display
- 4: Press and hold SET button until Set appears and flashes on the display
- 5: Press and hold SET button until Set sign disappears and the first digit start flashing
- 6: Press and release SET button to change first digit by 1, repeat until required number is displayed
- 7: Press and hold SET button to advance to the next digit
- 8: Repeat actions 6 & 7 until all the digits on the display have been programmed
- 9: Once the last digit has been programmed, press and hold the SET button until Set flashes in the display
- 10: Press and release SET button to cancel the flashing Set on the display
- 11: The micrometer is now set and ready for use

Electronic Micrometer: 50-450-150

Page 3 of 4

Measuring Force:	5 – 10N
Power Consumption:	Greater than 35 milliamps
Operating Temperature:	0 – 40 deg.C
Storage Temperature:	-20 to 60 deg. C
Protection Class:	IP54 (resistant to water splash)

Operating Care

Clean measuring faces with a clean soft cloth only

Do not use any organic solvent for cleaning such as acetone etc.

Keep instrument away from strong magnetic fields and high voltage environments which can affect the correct working of the electronic pack

Prevent the ingress of oil and liquids into the electronics

Do not use or store the micrometer in direct sunlight, or in an excessively hot or cold environment

Remove battery if the instrument is not to be used for a long period of time

Do not disassemble or drop the instrument

Do not mark the instrument by engraving, etching or any other permanent method of marking as this will invalidate the warranty

Fault Finding

Failure	Causes	Remedy
Display: "E 1" Display: "Exxxxx"	Measured value is over display range	Reset the origin or change to relative mode
Display: "E 2"	The origin is too great	Reset the origin
Display: "E 3" Display: "E 8"	1 The micrometer is disturbed 2 Something wrong with sensor	1 Reset the battery 2 return the micrometer for repair
Measured value is not correct	1 Measuring surfaces are not clean 2 The origin is incorrect	1 Clean measuring surfaces 2 Reset the origin
Display is confused or dead	Strong disturbance to micrometer	Reset battery
No display Display is blurring Battery sign appears	Battery voltage below 1.45V	Replace battery

Electronic Micrometer 50-450-150

Page 4 of 4

Mechanical Thimble and Sleeve

Reading Example: Metric

When reading the micrometer ensure that your line of sight is directly above the graduated scale on the sleeve and the thimble scale to avoid parallax reading errors

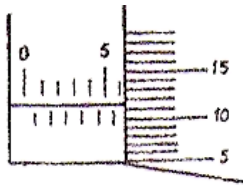

Example for division 0.01mm

Reading:

From Sleeve: 6mm

From thimble: 0.11mm

Final readings should be

$$6. + 0.11 = 6.11\text{mm}$$

Cleaning and Basic Checking Procedure

Remove any oil, grease, dust or small particles which may cause damage to the micrometer or affect its accuracy when taking measurements. Use a soft lint free cloth or paper together with a proprietary instrument cleaning agent. Do not use acetone as this can damage parts of the micrometer

Before use check that the ratchet mechanism functions correctly

Check the spindle movement by using the ratchet stop to traverse the spindle through its complete travel

Check that the measuring faces are in good condition

Check the locking mechanism works correctly

Zero Point Checking and Adjustment

Use the ratchet stop to move the spindle until it touches the fixed anvil. Allow the ratchet to turn $1\frac{1}{2}$ to 2 revolutions for the final positioning

The zero point on the thimble should now coincide with the reference graduated base line on the sleeve

For micrometers above 25mm / 1" use the supplied setting standard or a gauge block to check the zero position

If the zero point does not line up as required, it can be corrected by using the following procedure

When the zero point deviation on the thimble is under 2 divisions from the graduated base line

Turn the sleeve using the "C" spanner provided until correct alignment is achieved

When the zero point deviation on the thimble is over 2 divisions from the graduated base line

Hold the frame and the thimble and loosen the ratchet stop using the spanner provided

Disconnect the coupling of the thimble to the spindle by giving a light shock to the side of the thimble

Turn the thimble until the zero point is in alignment with the base line on the sleeve

Press the thimble against the spindle and re-tighten with the spanner to achieve a positive coupling

Re-check the zero position, any final small adjustment can now be made using the "C" spanner to re-position the sleeve to the thimble zero