

PE micro

xPC56XXMB User Manual



xPC56XXMBUM
Rev. 1.00
June 2008

 **freescale**[™]
Alliance Member

Purchase Agreement

P&E Microcomputer Systems, Inc. reserves the right to make changes without further notice to any products herein to improve reliability, function, or design. P&E Microcomputer Systems, Inc. does not assume any liability arising out of the application or use of any product or circuit described herein.

This software and accompanying documentation are protected by United States Copyright law and also by International Treaty provisions. Any use of this software in violation of copyright law or the terms of this agreement will be prosecuted.

All the software described in this document is copyrighted by P&E Microcomputer Systems, Inc. Copyright notices have been included in the software.

P&E Microcomputer Systems authorizes you to make archival copies of the software and documentation for the sole purpose of back-up and protecting your investment from loss. Under no circumstances may you copy this software or documentation for the purpose of distribution to others. Under no conditions may you remove the copyright notices from this software or documentation.

This software may be used by one person on as many computers as that person uses, provided that the software is never used on two computers at the same time. P&E expects that group programming projects making use of this software will purchase a copy of the software and documentation for each user in the group. Contact P&E for volume discounts and site licensing agreements.

P&E Microcomputer Systems does not assume any liability for the use of this software beyond the original purchase price of the software. In no event will P&E Microcomputer Systems be liable for additional damages, including any lost profits, lost savings or other incidental or consequential damages arising out of the use or inability to use these programs, even if P&E Microcomputer Systems has been advised of the possibility of such damage.

By using this software, you accept the terms of this agreement.

© 2008 P&E Microcomputer Systems, Inc. "MS-DOS" and "Windows" are registered trademarks of Microsoft Corporation. "Freescale" and "ColdFire" are registered trademarks of Freescale, Inc. "IBM" and "PowerPC" are registered trademarks of IBM corporation.

P&E Microcomputer Systems, Inc.
P.O. Box 2044
Woburn, MA 01888
617-923-0053
<http://www.pemicro.com>

Manual version 1.00

1	OVERVIEW.....	1
1.1	Package Contents	2
1.2	Supported Devices	2
1.3	Recommended Materials	2
1.4	Handling Precautions	3
2	HARDWARE FEATURES.....	4
2.1	xPC56XXMB Board Features.....	4
2.2	Pin Numbering for Jumpers.....	5
3	xPC56XXMB HARDWARE & JUMPER SETTINGS.....	7
3.1	Power Supplies	7
3.2	LEDs.....	10
3.3	Buttons	11
3.4	LIN.....	13
3.5	SCI	18
3.6	CAN.....	20
3.7	FlexRay	23
3.8	Potentiometer	27
4	DEBUGGING/PROGRAMMING xPC56XX MOTHERBOARD	29
4.1	Hardware Solutions At A Glance.....	29
4.2	USB-ML-PPCNEXUS Key Features	29
4.3	Cyclone MAX Key Features	29
4.4	Working With P&E's USB-ML-PPCNEXUS	30
4.5	Working With P&E's Cyclone MAX	31

1 OVERVIEW

The xPC56XXMB Motherboard is an evaluation system supporting Freescale's MPC56xx microprocessors. The complete system consists of an xPC56XXMB Motherboard and an xPC56xxADPT Mini-Module (not included) which plugs into the motherboard. Different Mini-Modules are available for evaluating the different devices in the MPC56xx family of microprocessors. The evaluation system (Motherboard & Mini-Module) allows full access to the CPU, all of the CPU's I/O signals, and the motherboard peripherals (such as CAN, SCI, LIN).

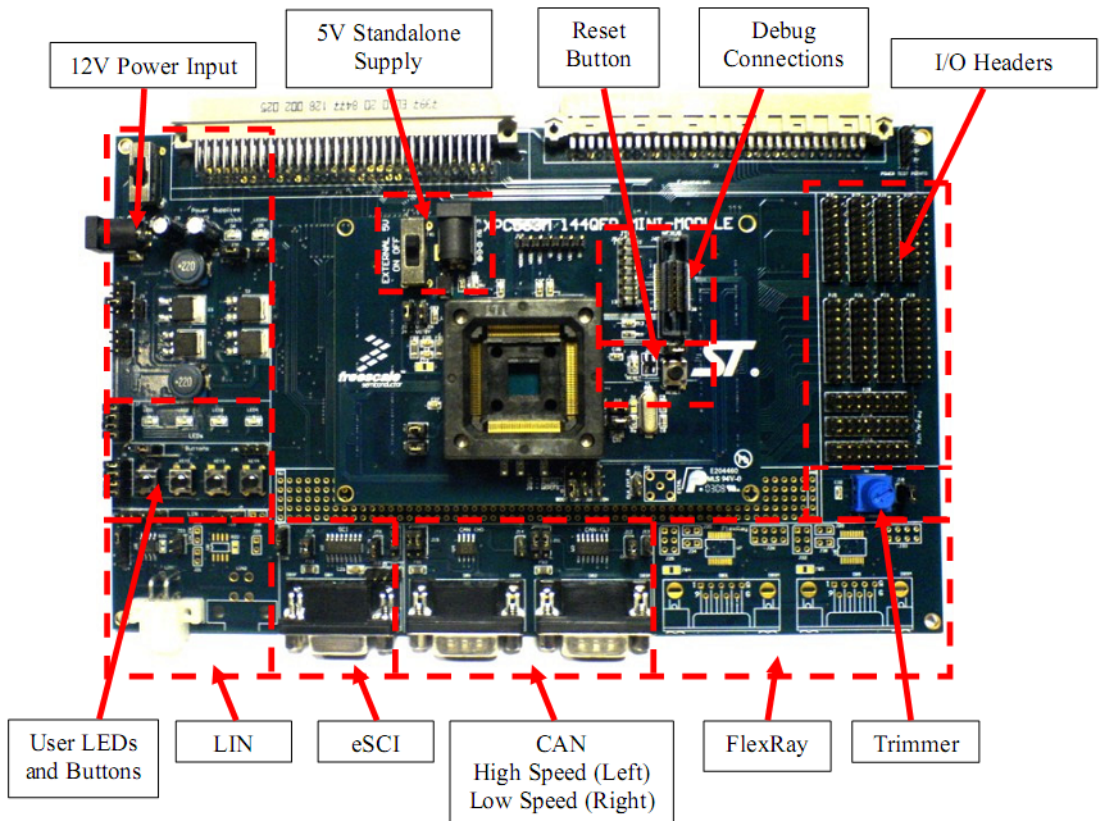

Figure 1-1: Overview of the xPC56XXMB with Mini-Module (not included)

1.1 Package Contents

An xPC56XXMB Evaluation Kit includes the following items:

- One xPC56XXMB Motherboard
- One xPC56XX Resources CD-ROM
- Freescale Warranty Card

1.2 Supported Devices

To work with a specific device in the MPC56xx family of microprocessors, the correct Mini-Module (not included) must be used to plug into the xPC56XXMB motherboard. Below is a list of all available Mini-Modules and their supported devices:

xPC560BADPT100S Mini-Module: Supports MPC5604BEMLL

xPC560BADPT144S Mini-Module: Supports MPC5604BEMLQ

xPC560BADPT208S Mini-Module: Supports MPC5604BEMMG

xPC560PADPT100S Mini-Module: Supports MPC5604PEFMLL

xPC560PADPT144S Mini-Module: Supports MPC5604PEFMLQ

xPC560SADPT144S Mini-Module: Supports MPC5606SEMLQ

xPC560SADPT176S Mini-Module: Supports MPC5606SEMLU

xPC560SADPT208S Mini-Module: Supports MPC5606SEMMG

xPC563MADPT144S Mini-Module: Supports MPC5633MMLQ80

xPC563MADPT208S Mini-Module: Supports MPC5633MMMG80

1.3 Recommended Materials

- Freescale device reference manual and datasheet
- xPC56XXMB schematic
- Mini-Module hardware manual and schematics

1.4 Handling Precautions

Please take care to handle the package contents in a manner such as to prevent electrostatic discharge.

2 HARDWARE FEATURES

2.1 xPC56XXMB Board Features

- ON/OFF Power Switch w/ LED indicators
- A 12VDC power supply input barrel connector
- Onboard ST Microelectronics L9758 regulator provides three different power voltages simultaneously: 5V, 3.3V, and 1.2V
- Onboard peripherals can be configured to operate at 5V or 3.3V logic levels
- Two CAN channels with jumper enables
 - One CAN channel with High-Speed transceiver and DB9 male connector
 - One CAN channel with Low-Speed Fault Tolerant and High-Speed transceiver (selectable with jumpers) and DB9 male connector
- Two LIN channels with jumper enables
 - One channel with transceiver and pin header connector populated
 - One channel with footprints only
- One SCI channel with jumper enables
 - Transceiver with DB9 female connector
- Two FlexRay channels with jumper enables
 - One channel with transceiver and DB9 male connector
 - One channel with footprint only
- Four user push buttons with jumper enables and polarity selection
- Four user LED's with jumper enables
- One potentiometer for analog voltage input
- Pin array for accessing all I/O signals
- Expansion connectors for accessing all I/O signals
- Development zone with 0.1" spacing and SOIC footprint prototyping

- Specifications:
 - Board Size 5.5" x 9.0"
 - 12VDC Center Positive power supply with 2.5/5.5mm barrel connector

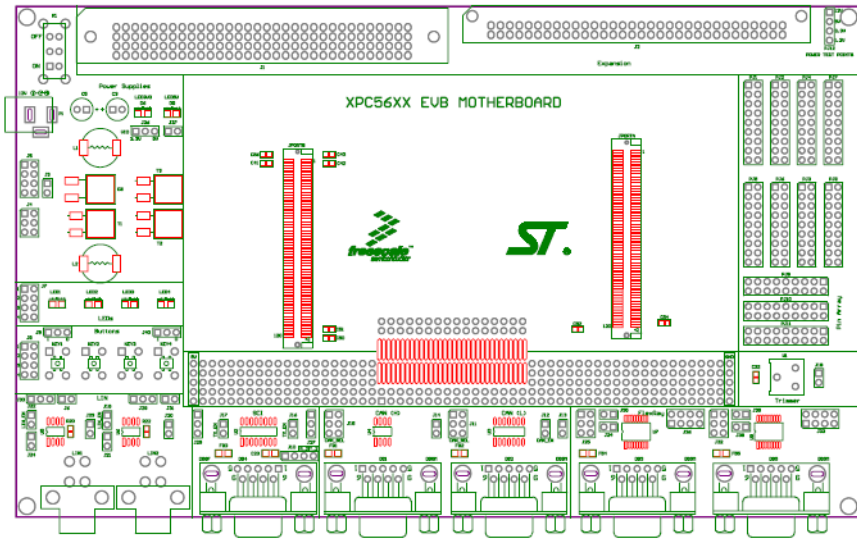

Figure 2-2: xPC56XXMB Top Component Placement

2.2 Pin Numbering for Jumpers

Jumpers for both the xPC56XXMB motherboard have a rounded corner to indicate the position of pin 1. See examples below for the numbering convention used in this manual for jumper settings.

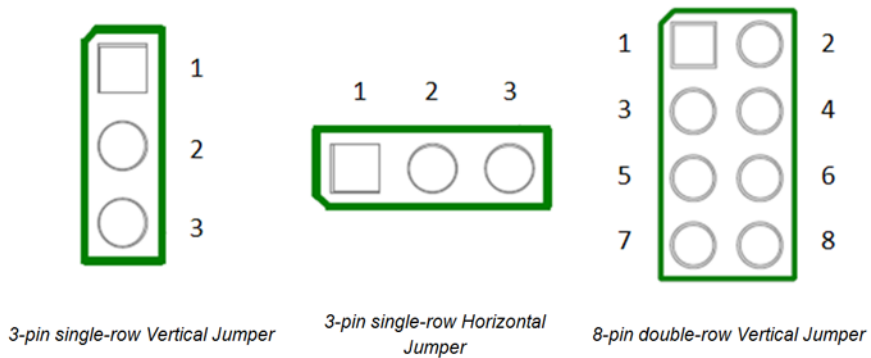

Figure 2-3: Pin Numbering

3 xPC56XXMB HARDWARE & JUMPER SETTINGS

3.1 Power Supplies

The xPC56XXMB obtains its power from the 12VDC Center Positive input barrel connector. The following jumpers are used to configure the power supply output:

J3 – VSA Tracking Regulator Configuration

Jumper Setting	Effect
On	The ST L9758 tracking regulator VSA tracks the input voltage at its TRACK_REF pin.
Off (default)	The ST L9758 tracking regulator VSA tracks 5V

J4 – VPROG Regulators Control

Jumper Setting	Position	Effect
1+2	On	V_{KAM} regulator output is programmed to 1V
	Off (default)	V_{KAM} regulator output is programmed to 1.5V
3+4	On	V_{STBY} regulator output is programmed to 2.6V
	Off (default)	V_{STBY} regulator output is programmed to 3.3V

5+6	On	V_{DLL} regulator output is programmed to 2.6V
	Off (default)	V_{DLL} regulator output is programmed to 3.3V

J5 – Regulators Enable & Standby

Jumper Setting	Position	Effect
1+2	On	The power regulator is always on
	Off (default)	The power regulator is in standby if jumpers 5+6 are also in the “off” position
3+4	On	VSB, VSC, and VSD tracking regulators are disabled
	Off (default)	VSB, VSC, and VSD tracking regulators are enabled
5+6	On (default)	The power regulator is always on
	Off	The power regulator is in standby if jumpers 1+2 are also in the “off” position
7+8	On	V_{DLL} and V_{CORE} regulators are disabled
	Off (default)	V_{DLL} and V_{CORE} regulators are enabled

J36 – VIO Peripherals Logic Level

Jumper Setting	Effect
1+2	Onboard peripherals are configured for 3.3V logic
2+3 (default)	Onboard peripherals are configured for 5V logic

J37 – VBat low voltage detection

Jumper Setting	Effect
On	Low battery detection is enabled
Off (default)	Low battery detection is disabled

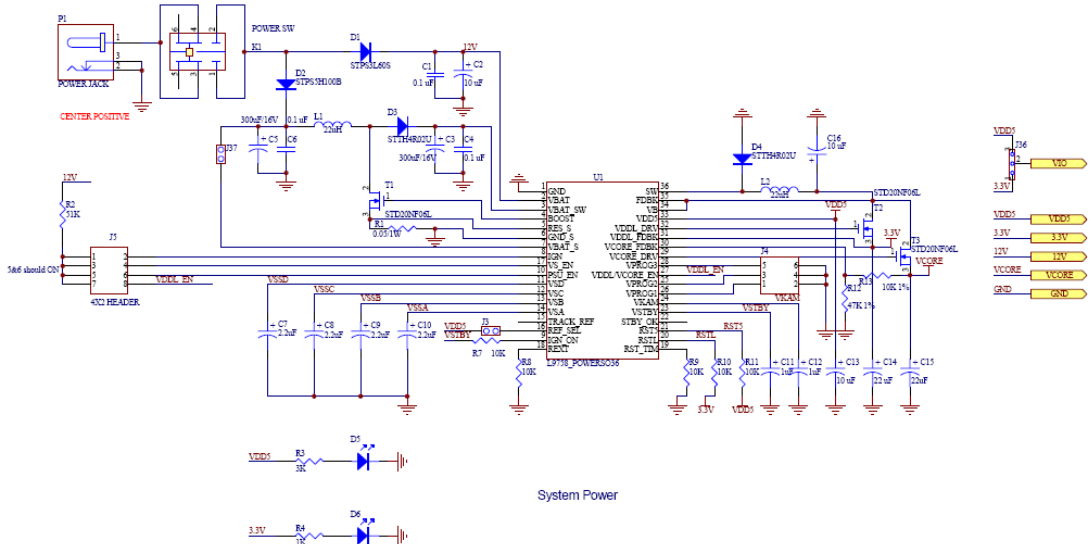

Figure 3-1: Power Supply circuitry schematic

3.2 LEDs

There are four user LEDs available on the xPC56XXMB. All LEDs are active low.

J7 – LEDs Enable

Controls whether the LEDs on the xPC56XXMB motherboard are connected to I/O pins of the processor. The exact pins used are dependent on the specific Mini-Module plugged into the motherboard. Please refer to the Mini-Module hardware manual for more details.

Jumper Setting	Effect
----------------	--------

1+2 (default on)	LED1 connected to processor I/O pin
3+4 (default on)	LED2 connected to processor I/O pin
5+6 (default on)	LED3 connected to processor I/O pin
7+8 (default on)	LED4 connected to processor I/O pin

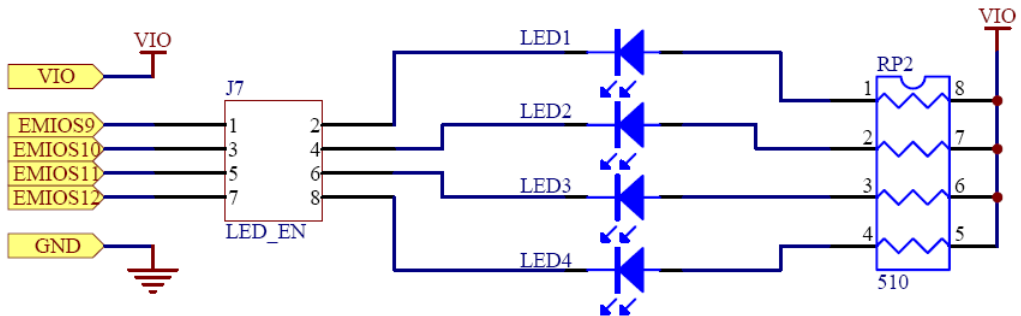

Figure 3-2: LEDs circuitry schematic

3.3 Buttons

There are four user buttons available on the xPC56XXMB.

J8 – Buttons Enable

Controls whether the buttons on the xPC56XXMB motherboard are connected to I/O pins of the processor. The exact pins used are dependent on the specific Mini-Module plugged into the motherboard. Please refer to the

Mini-Module hardware manual for more details.

Jumper Setting	Effect
1+2 (default on)	KEY1 connected to processor I/O pin
3+4 (default on)	KEY2 connected to processor I/O pin
5+6 (default on)	KEY3 connected to processor I/O pin
7+8 (default on)	KEY4 connected to processor I/O pin

J9 – Buttons Driving Configuration

Selects whether the buttons drive logic high or drive logic low when pressed.

Jumper Setting	Effect
1+2	When pressed, buttons will send logic high to the connected I/O pin
2+3 (default)	When pressed, buttons will send logic low to the connected I/O pin

J40 – Buttons Idle Configuration

Selects whether the I/O pins are pulled logic high or pulled logic low. This controls the default logic level of the I/O pins when the buttons are not

pressed.

Jumper Setting	Effect
1+2 (default)	I/O pins connected to the buttons are pulled up to logic high
2+3	I/O pins connected to the buttons are pulled down to logic low

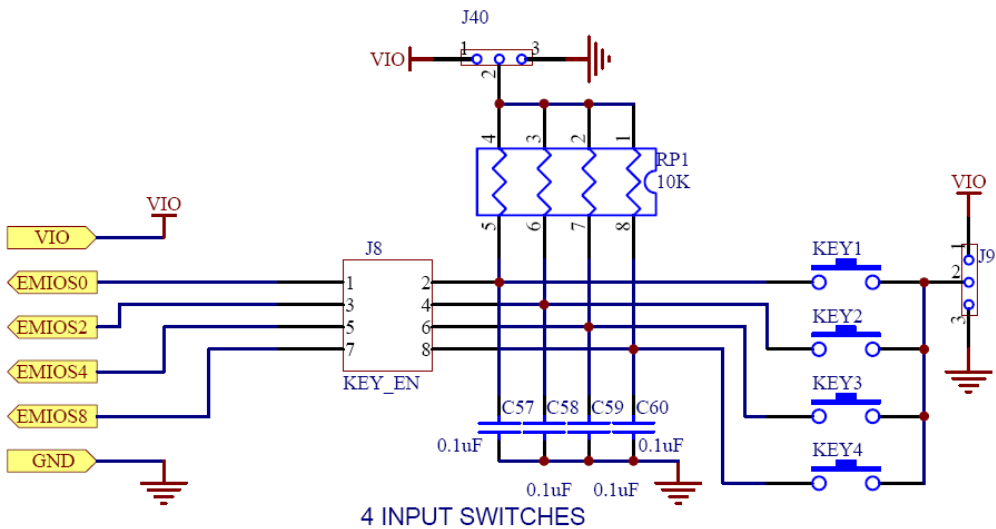

Figure 3-3: Buttons circuitry schematic

3.4 LIN

There are footprints for two LIN connections on the xPC56XXMB. By default, one LIN circuit is assembled (LIN1) and the other circuit is left unpopulated (LIN2).

J6 – LIN1 pin2 configuration

Jumper Setting	Effect
On	Pin 2 of the LIN1 connector is connected to 12V
Off (default)	Pin 2 of the LIN1 connector is not connected to 12V

J22 – LIN1 enable

Jumper Setting	Effect
On (default)	Enables the LIN1 transceiver
Off	Disables the LIN1 transceiver

J23 – LIN1 master selection

Jumper Setting	Effect
On	LIN1 is configured as a master node
Off (default)	LIN1 is configured as a slave node

J24 – LIN1 pin1 configuration

Jumper Setting	Effect
----------------	--------

On	Pin 1 of the LIN1 connector is connected to 12V
Off (default)	Pin 1 of the LIN1 connector is not connected to 12V

J27 – LIN1/SCI TxD selection

Controls whether the TxD pin on LIN1 or SCI is connected to the default I/O pin on the processor. The exact pins used are dependent on the specific Mini-Module plugged into the motherboard. Please refer to the Mini-Module hardware manual for more details.

Jumper Setting	Effect
1+2	The LIN1 TxD pin is connected to a processor I/O pin. This should be set if enabling LIN1.
2+3	The SCI TxD pin is connected to a processor I/O pin.

J28 – LIN1/SCI RxD selection

Controls whether the RxD pin on LIN1 or SCI is connected to the default I/O pin on the processor. The exact pins used are dependent on the specific Mini-Module plugged into the motherboard. Please refer to the Mini-Module hardware manual for more details.

Jumper Setting	Effect
1+2	The LIN1 RxD pin is connected to a processor I/O pin. This should be set if enabling LIN1.
2+3	The SCI RxD pin is connected to a processor I/O pin.

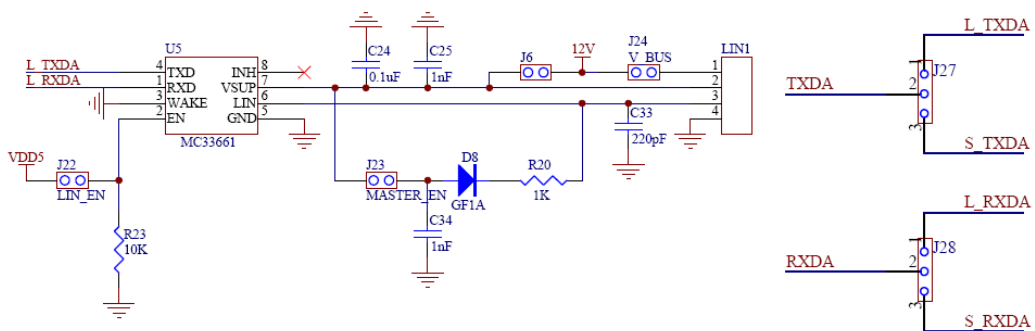

Figure 3-4: LIN1 Schematic

J31 – LIN2 pin2 configuration

Jumper Setting	Effect
On	Pin 2 of the LIN2 connector is connected to 12V
Off (default)	Pin 2 of the LIN2 connector is not connected to 12V

J19 – LIN2 enable

Jumper Setting	Effect
On	Enables the LIN2 transceiver
Off (default)	Disables the LIN2 transceiver

J20 – LIN2 master selection

Jumper Setting	Effect
On	LIN2 is configured as a master node
Off (default)	LIN2 is configured as a slave node

J21 – LIN2 pin1 configuration

Jumper Setting	Effect
On	Pin 1 of the LIN2 connector is connected to 12V
Off (default)	Pin 1 of the LIN2 connector is not connected to 12V

J29 – LIN2/SCI TxD selection

Controls whether the TxD pin on LIN2 or SCI is connected to the default I/O pin on the processor. The exact pins used are dependent on the specific Mini-Module plugged into the motherboard. Please refer to the Mini-Module hardware manual for more details.

Jumper Setting	Effect
1+2	The LIN2 TxD pin is connected to a processor I/O pin. This should be set if enabling LIN2.
2+3	The SCI TxD pin is connected to a processor I/O pin.

J30 – LIN2/SCI RxD selection

Controls whether the RxD pin on LIN2 or SCI is connected to the default I/O pin on the processor. The exact pins used are dependent on the specific Mini-Module plugged into the motherboard. Please refer to the Mini-Module hardware manual for more details.

Jumper Setting	Effect
1+2	The LIN2 RxD pin is connected to a processor I/O pin. This should be set if enabling LIN2.
2+3	The SCI RxD pin is connected to a processor I/O pin.

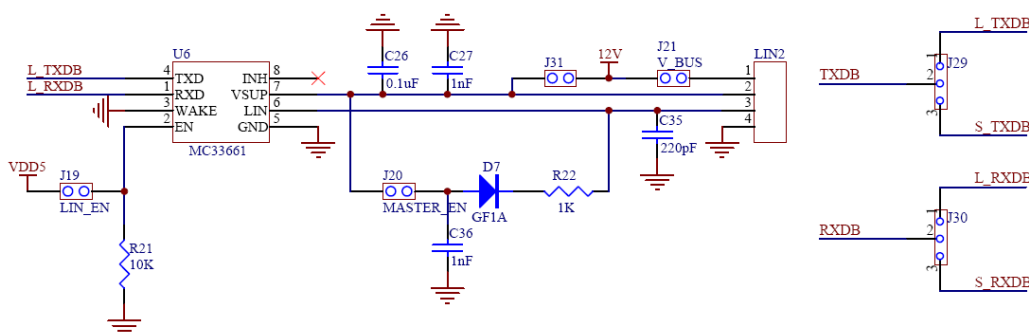

Figure 3-5: LIN2 schematic (Not populated by default)

3.5 SCI

One SCI interface is available on the xPC56XXMB.

J16 – SCI TxD Enable

Jumper Setting	Effect
On (default)	Enables SCI transmit
Off	Disables SCI transmit

J17 – SCI RxD Enable

Jumper Setting	Effect
On (default)	Enables SCI receive
Off	Disables SCI receive

J27 – LIN1/SCI TxD selection

Controls whether the TxD pin on LIN1 or SCI is connected to the default I/O pin on the processor. The exact pins used are dependent on the specific Mini-Module plugged into the motherboard. Please refer to the Mini-Module hardware manual for more details.

Jumper Setting	Effect
1+2	The LIN1 TxD pin is connected to a processor I/O pin.
2+3	The SCI TxD pin is connected to a processor I/O pin. This should be set if enabling SCI.

J28 – LIN1/SCI RxD selection

Controls whether the RxD pin on LIN1 or SCI is connected to the default I/O pin on the processor. The exact pins used are dependent on the specific Mini-Module plugged into the motherboard. Please refer to the Mini-Module hardware manual for more details.

Jumper Setting	Effect
1+2	The LIN1 RxD pin is connected a processor I/O pin.
2+3	The SCI RxD pin is connected to a processor I/O pin. This should be set if enabling SCI.

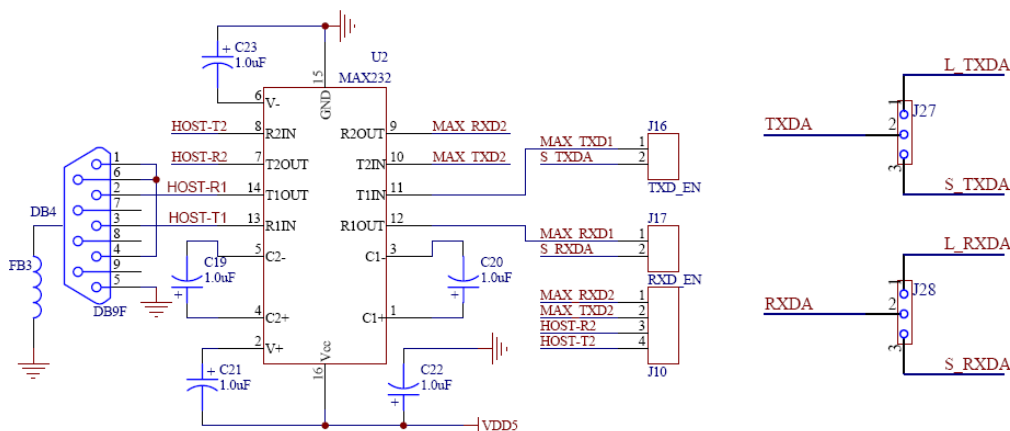

Figure 3-6: SCI schematic

3.6 CAN

Two CAN interfaces are implemented on the xPC56XXMB: a high-speed CAN interface and a low-speed CAN interface.

J14 – CAN (H) Transmit Enable

Jumper Setting	Effect
On	Enables CAN transmission
Off (default)	Disables CAN transmission

J15 – CAN (H) TxD/RxD Enable

Controls which I/O pins on the processor are connected to the TxD and RxD pins on CAN (H). The exact pins used are dependent on the specific Mini-Module plugged into the motherboard. Please refer to the Mini-Module hardware manual for more details.

Jumper Setting	Effect
1+3 (default)	The RxD pin of the CAN (H) interface is connected to a processor I/O pin.
3+5	The RxD pin of the CAN (H) interface is connected to a processor I/O pin.
2+4 (default)	The TxD pin of the CAN (H) interface is connected to a processor I/O pin.
4+6	The TxD pin of the CAN (H) interface is connected to a processor I/O pin.

J13 – CAN (L) CTE

Jumper Setting	Effect
----------------	--------

On	Enables CAN transmission
Off (default)	Disables CAN transmission

J11 – CAN (L) TxD/RxD Enable

Controls which I/O pins on the processor are connected to the TxD and RxD pins on CAN (L). The exact pins used are dependent on the specific Mini-Module plugged into the motherboard. Please refer to the Mini-Module hardware manual for more details.

Jumper Setting	Effect
1+3	The RxD pin of the CAN (L) interface is connected to a processor I/O pin.
3+5 (default)	The RxD pin of the CAN (L) interface is connected to a processor I/O pin.
2+4	The TxD pin of the CAN (L) interface is connected to a processor I/O pin.
4+6 (default)	The TxD pin of the CAN (L) interface is connected to a processor I/O pin.

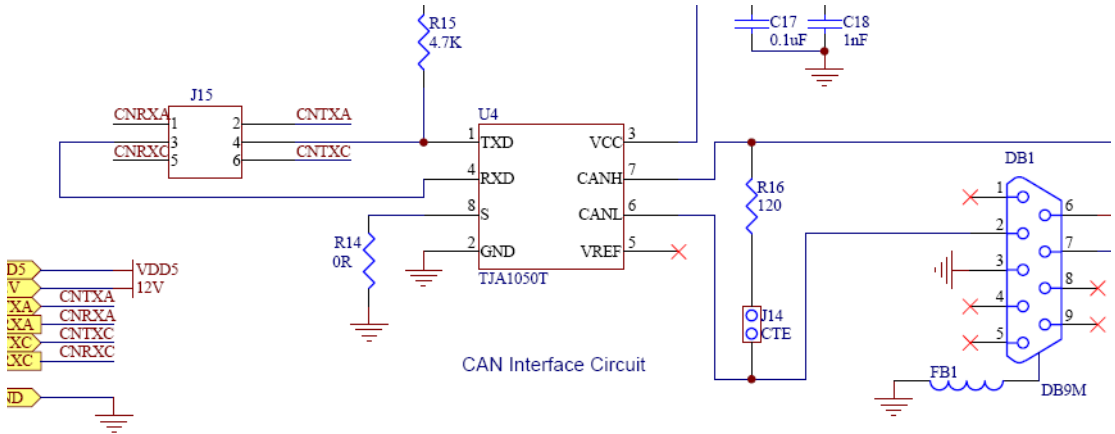

Figure 3-7: High Speed CAN schematic

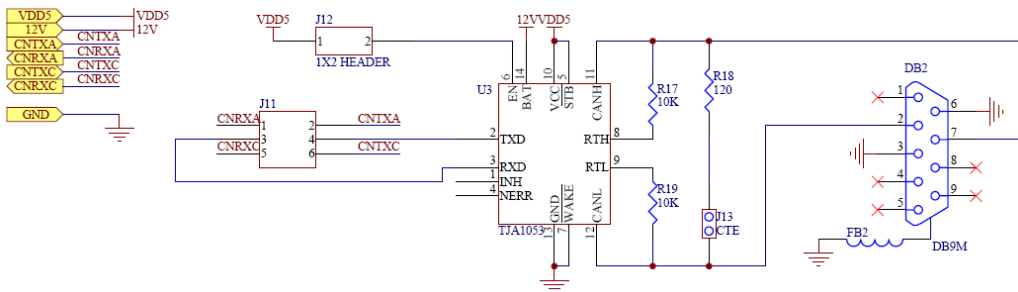

Figure 3-8: Low Speed CAN schematic

3.7 FlexRay

The xPC56XXMB has footprints for two FlexRay interfaces. However, only one circuit is assembled by default. The FlexRay circuit comprises of two DB9 connectors. DB3 contains signals for both FlexRay channels and is compatible with major FlexRay tools. DB5 contains channel B signal, thereby also allowing 2 separate FlexRay connectors for channel A and channel B operation.

J25 – FlexRay Bus Driver 1 Enable

Controls which I/O pins on the processor are connected to the TxD and RxD pins on FlexRay Bus Driver. The exact pins used are dependent on the specific Mini-Module plugged into the motherboard. Please refer to the Mini-Module hardware manual for more details.

Jumper Setting	Effect
1+2 (default on)	The TXD pin on the FlexRay Bus Driver is connected to a processor I/O pin.
3+4 (default on)	The TXEN pin on the FlexRay Bus Driver is connected to a processor I/O pin.
5+6 (default on)	The RXD pin on the FlexRay Bus Driver is connected to a processor I/O pin.

J26 – FlexRay Bus Driver 1 Pull-up Enable

Controls which pins on the FlexRay Bus Driver are pulled up.

Jumper Setting	Effect
1+2	The BGE pin on the FlexRay Bus Driver is pulled up to 5V
3+4	The STBN pin on the FlexRay Bus Driver is pulled up to 5V
5+6 (default on)	The EN pin on the FlexRay Bus Driver is pulled up to 5V

7+8 (default on)	The WAKE pin on the FlexRay Bus Driver is pulled up to 5V
------------------	---

J34 & J35 FlexRay 1 Terminal Resistor Connection

Jumper Setting	Effect
On	Terminal resistors connected
Off (default)	Terminal resistors not connected

J32 – FlexRay Bus Driver 2 Enable

Controls which I/O pins on the processor are connected to the TxD and RxD pins on FlexRay Bus Driver. The exact pins used are dependent on the specific Mini-Module plugged into the motherboard. Please refer to the Mini-Module hardware manual for more details.

Jumper Setting	Effect
1+2	The TXD pin on the FlexRay Bus Driver is connected to a processor I/O pin.
3+4	The TXEN pin on the FlexRay Bus Driver is connected to a processor I/O pin.
5+6	The RXD pin on the FlexRay Bus Driver is connected to a processor I/O pin.

J33 – FlexRay Bus Driver 2 Pull-up Enable

Controls which pins on the FlexRay Bus Driver are pulled up.

Jumper Setting	Effect
1+2	The BGE pin on the FlexRay Bus Driver is pulled up to 5V
3+4	The STBN pin on the FlexRay Bus Driver is pulled up to 5V
5+6	The EN pin on the FlexRay Bus Driver is pulled up to 5V
7+8	The WAKE pin on the FlexRay Bus Driver is pulled up to 5V

J38 & J39 – FlexRay 2 Terminal Resistor Connection

Jumper Setting	Effect
On	Terminal resistors connected
Off (default)	Terminal resistors not connected

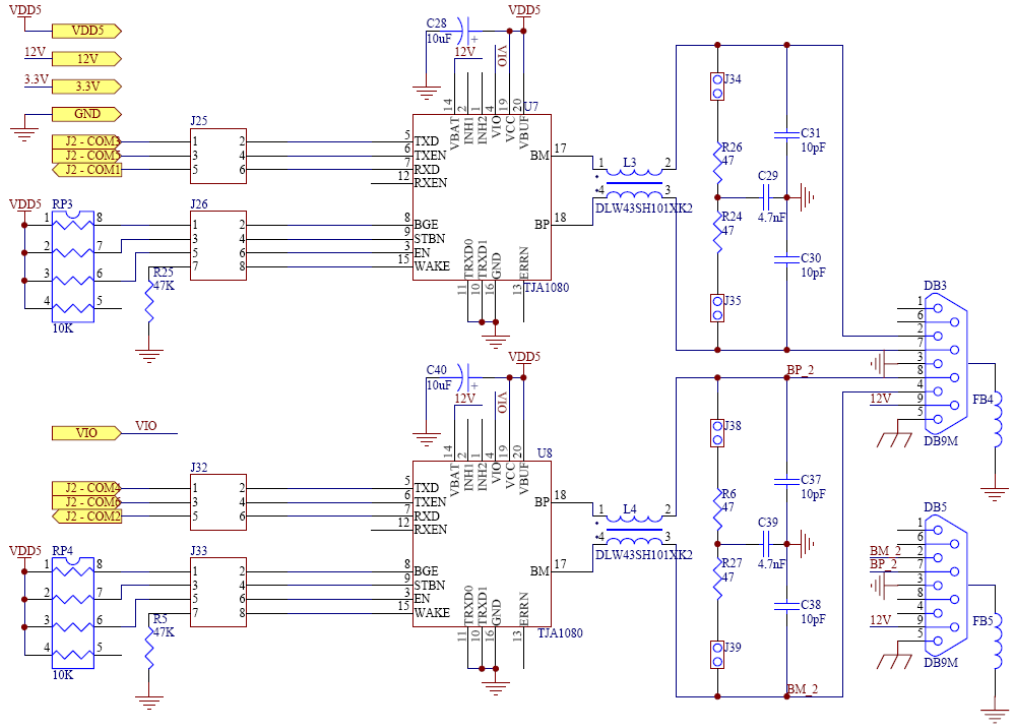

Figure 3-9: FlexRay schematic

3.8 Potentiometer

A potentiometer is available on the xPC56XXMB to allow an analog voltage input.

J18 – POT Enable

Jumper Setting	Effect
----------------	--------

On (default)	The potentiometer wiper terminal is connected to a processor I/O pin. The exact pin used is dependent on the specific Mini-Module plugged into the motherboard. Please refer to the Mini-Module hardware manual for more details.
Off	The potentiometer wiper terminal is left disconnected.

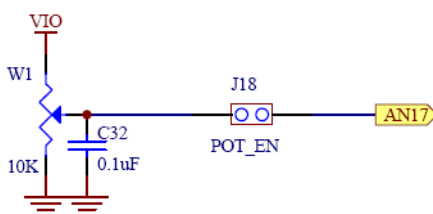

Figure 3-10: Potentiometer schematic

4 DEBUGGING/PROGRAMMING xPC56XX MOTHERBOARD

P&E provides hardware and software tools for debugging and programming the xPC56XXMB (with Mini-Module, sold separately).

P&E's USB-ML-PPCNEXUS and Cyclone MAX offer two effective hardware solutions, depending on your needs. The USB-ML-PPCNEXUS is a development tool that will enable you to debug your code and program it onto your target. The Cyclone MAX is a more versatile and robust development tool with advanced features and production programming capabilities, as well as Ethernet support.

More information is available below to assist you in choosing the appropriate development tool for your needs.

4.1 Hardware Solutions At A Glance

The USB-ML-PPCNEXUS offers an affordable and compact solution for your development needs, and allows debugging and programming to be accomplished simply and efficiently. Those doing rapid development will find the USB-ML-PPCNEXUS easy to use and fully capable of fast-paced debugging and programming.

The Cyclone MAX is a more complete solution designed for both development and production. The Cyclone MAX features multiple communications interfaces (including USB, Ethernet, and Serial), stand-alone programming functionality, high speed data transfer, a status LCD, and many other advanced capabilities.

Below is an overview of the features and intended use of the USB-ML-PPCNEXUS and Cyclone MAX.

4.2 USB-ML-PPCNEXUS Key Features

- Programming and debugging capabilities
- Compact and lightweight
- Communication via USB 2.0
- Supported by P&E software and Freescale's CodeWarrior

4.3 Cyclone MAX Key Features

- Advanced programming and debugging capabilities, including:

- PC-Controlled and User-Controlled Stand-Alone Operation
- Interactive Programming via Host PC
- In-Circuit Debugging, Programming, and Testing
- Compatible with Freescale's ColdFireV2/3/4, PowerPC 5xx/8xx/55xx/56xx, and ARM7 microcontroller families
- Communication via USB, Serial, and Ethernet Ports
- Multiple image storage
- LCD screen menu interface
- Supported by P&E software and Freescale's CodeWarrior

4.4 Working With P&E's USB-ML-PPCNEXUS



Figure 4-1: P&E's USB-ML-PPCNEXUS

4.4.1 Product Features & Implementation

P&E's USB-ML-PPCNEXUS Interface (USB-ML-PPCNEXUS) connects your target to your PC and allows the PC access to the debug mode on Freescale's PowerPC 5xx/8xx/55xx/56xx microcontrollers. It connects between a USB port on a Windows 2000/XP/2003/Vista machine and a standard 14-pin JTAG/Nexus connector on the target.

By using the USB-ML-PPCNEXUS Interface, the user can take advantage of the background debug mode to halt normal processor execution and use a PC to control the processor. The user can then directly control the target's execution, read/write registers and memory values, debug code on the processor, and program internal or external FLASH memory devices. The USB-ML-PPCNEXUS enables you to debug, program, and test your code on your board.

4.4.2 Software

The USB-ML-PPCNEXUS Interface works with Codewarrior as well as P&E's in-circuit debugger and flash programmer to allow debug and flash programming of the target processor. P&E's USB-ML-PPCNEXUS Development Packages come with the USB-ML-PPCNEXUS Interface, as well as flash programming software, in-circuit debugging software, Windows IDE, and register file editor.

4.5 Working With P&E's Cyclone MAX



P&E's Cyclone MAX

4.5.1 Product Features & Implementation

P&E's Cyclone MAX is an extremely flexible tool designed for debugging, testing, and in-circuit flash programming of Freescale's ColdFireV2/3/4, PowerPC 5xx/8xx/55xx/56xx, and ARM7 microcontrollers. The Cyclone MAX connects your target to the PC via USB, Ethernet, or Serial Port and enables you to debug your code, program, and test it on your board. After development is complete the Cyclone MAX can be used as a production tool on your manufacturing floor.

For production, the Cyclone MAX may be operated interactively via Windows-based programming applications as well as under batch or .dll commands from a PC. Once loaded with data by a PC it can be disconnected and operated manually in a stand-alone mode via the LCD menu and control buttons. The Cyclone MAX has over 3Mbytes of non-volatile memory, which allows the on-board storage of multiple programming images. When connected to a PC for programming or loading it can communicate via the ethernet, USB, or serial interfaces.

4.5.2 Software

The Cyclone MAX comes with intuitive configuration software and interactive programming software, as well as easy to use automated control software. The Cyclone MAX also functions as a full-featured debug interface, and is supported by Freescale's CodeWarrior as well as development software from P&E.

P&E's Cyclone MAX is also available bundled with additional software as part of various Development Packages. In addition to the Cyclone MAX, these Development Packages include in-circuit debugging software, flash programming software, a Windows IDE, and register file editor.



Freescale Controller Continuum

68HC08/S08/RS08/(S)12(X) ColdFire® V1 ColdFire® V2/V3/V4 PowerPC® Nexus® ARM®



Cyclone PRO

Cyclone MAX

©2008, P&E Microcomputer Systems, Inc. All rights reserved.

P&E Micrcomputer Systems, Inc.
P.O. Box 2044
Woburn, MA 01888

www.pemicro.com

Freescale™ and the Freescale logo are trademarks of Freescale Semiconductor, Inc.
All other product or service names are the property of their respective owners.
© Freescale Semiconductor, Inc. 2007.