



Specification

Mechanical

Product	Operation Force:
MSS3	150 ± 100gf (1.47N ± 0.98N)
MSS6	200 ± 150gf (1.96N ± 1.47N)

Stroke : 1.5mm
 Operation Temperature : -20°C to +70°C
 Storage Temperature : -40°C to +85°C

Electrical

Electrical Life : 10,000 cycles
 Non-switching Rating : 300mA, 4V DC
 Switching Rating : 25mA, 24V DC
 Contact Resistance : 100mΩ max.
 Insulation Resistance : 100MΩ min. (500V DC)
 Dielectric Strength : 500V AC / 1 minute
 Capacitance : 5pF max.
 Circuit : SPDT, SP3T, DPDT, SP4T

Material

Cover : Nickel silver
 Base : LCP High-Temp Thermoplastic
 Colour : Black
 Contact : Alloy copper, Gold Plated
 Terminal : Brass , Gold Plated
 Spring Plate : Stainless steel



Soldering Process

- Hand Soldering: Use a soldering iron of 30 watts, controlled at 350°C approximately 5 seconds.
- Reflow Soldering: When applying reflow soldering, the peak temperature or the reflow oven should be set at 260°C max.

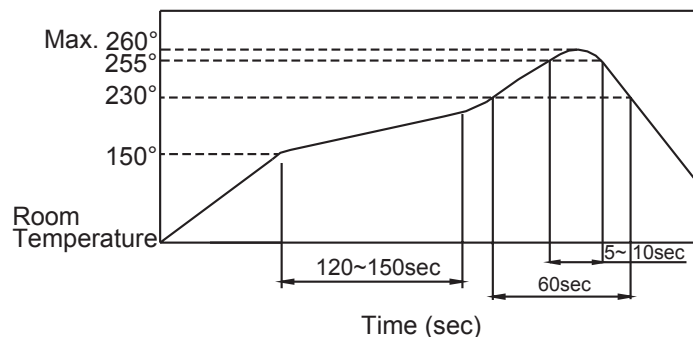

Dimensions

MSS3

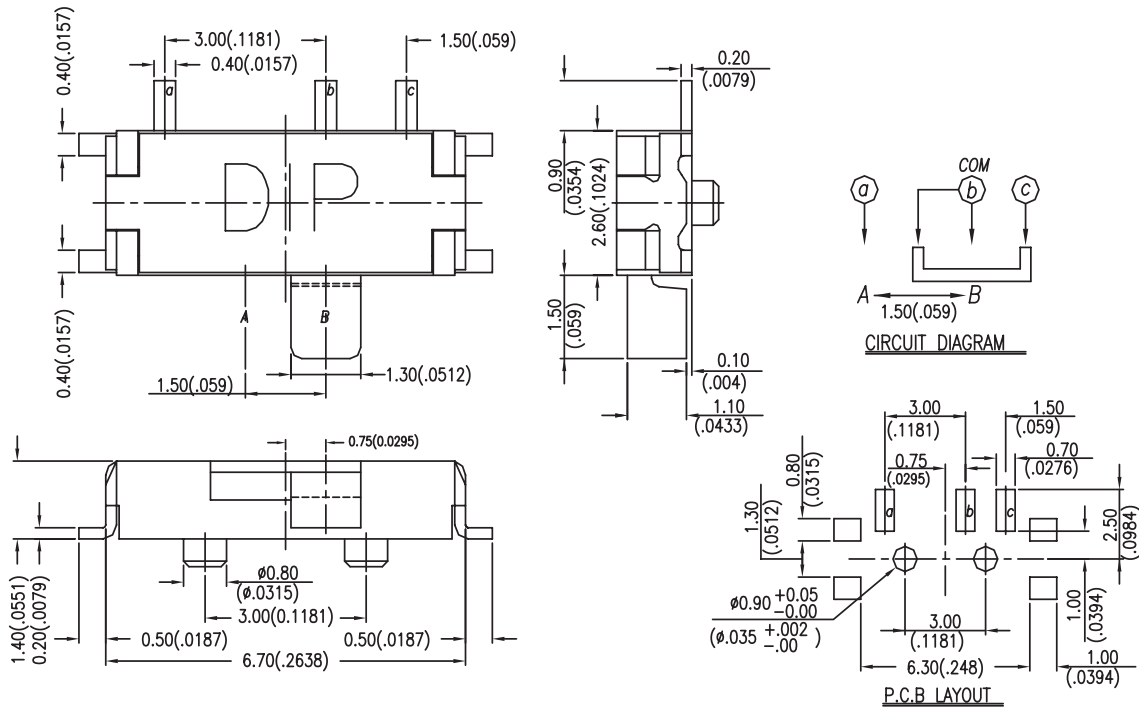

General Tolerance : $\pm 0.2\text{mm}$

MSS6

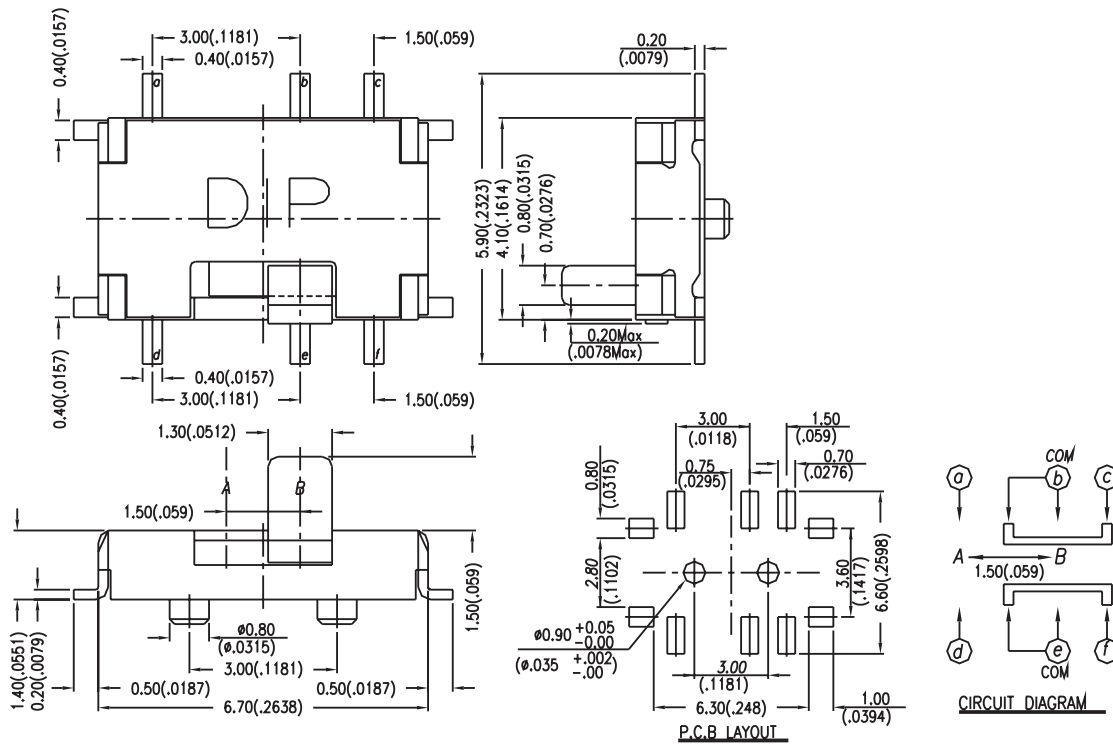

General Tolerance : $\pm 0.2\text{mm}$

Slide Switches



Packing

MSS3

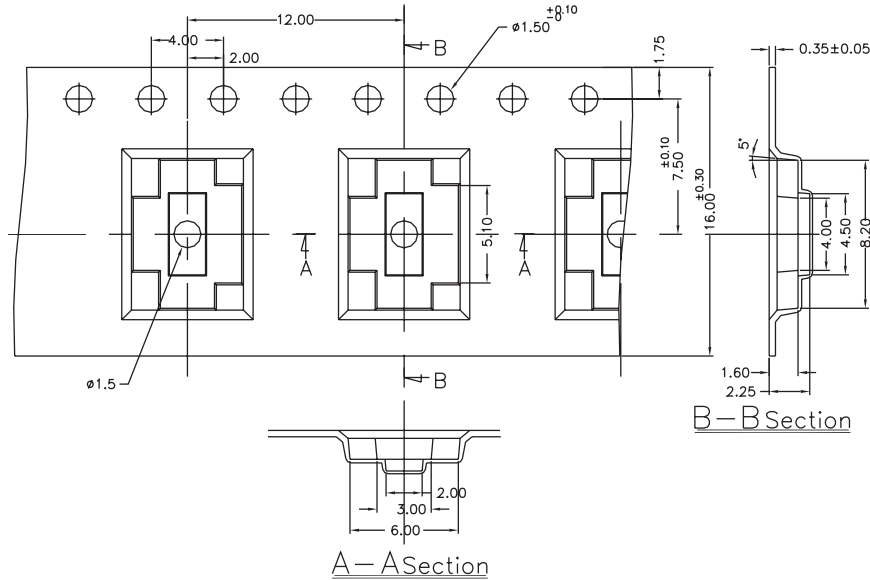

General Tolerance : ±0.1mm

MSS6

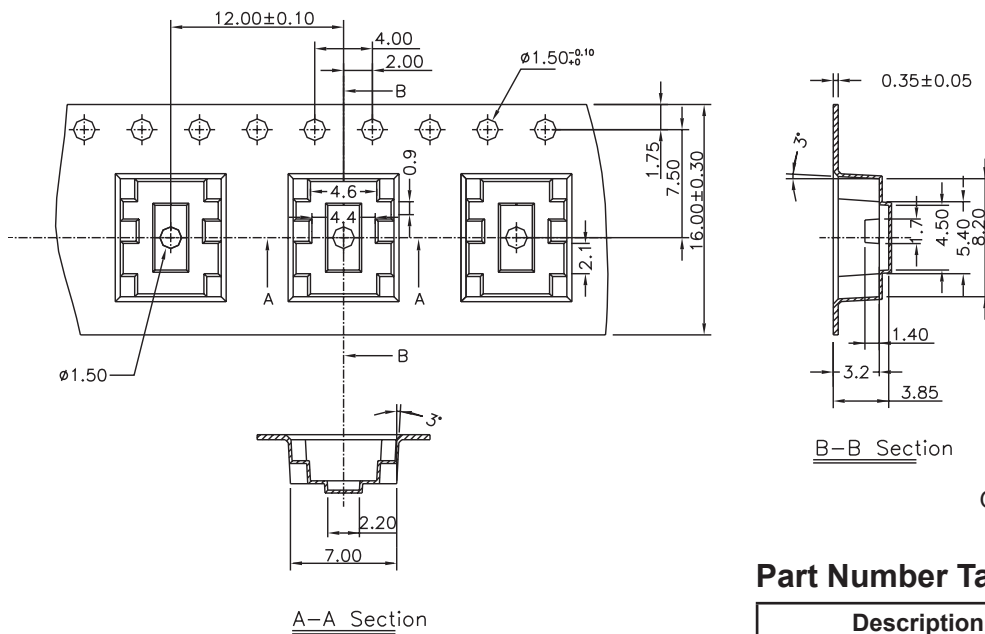

General Tolerance : ±0.1mm

Part Number Table

Description	Part Number
Switch, Slide, SPDT, SMD	MSS3-V-T/R
Switch, Slide, DPDT, SMD	MSS6-V-T/R

Important Notice : This data sheet and its contents (the "Information") belong to the members of the Premier Farnell group of companies (the "Group") or are licensed to it. No licence is granted for the use of it other than for information purposes in connection with the products to which it relates. No licence of any intellectual property rights is granted. The Information is subject to change without notice and replaces all data sheets previously supplied. The Information supplied is believed to be accurate but the Group assumes no responsibility for its accuracy or completeness, any error in or omission from it or for any use made of it. Users of this data sheet should check for themselves the Information and the suitability of the products for their purpose and not make any assumptions based on information included or omitted. Liability for loss or damage resulting from any reliance on the Information or use of it (including liability resulting from negligence or where the Group was aware of the possibility of such loss or damage arising) is excluded. This will not operate to limit or restrict the Group's liability for death or personal injury resulting from its negligence. Multicomp is the registered trademark of the Group. © Premier Farnell plc 2012.

