

# 5V Wide Optical Spectrum Laser Power Monitor IC

## ISL58328

The ISL58328 photo sensor IC has a wide optical spectral sensitivity from 400nm to 1000nm. It is good for multiple light sources application, such as laser based projectors. ISL58328 has two banks of three sets of gain registers. For a Pico-Projector application, the two banks of gain resistors can be used to monitor bias level and peak level of each wavelength. Bank switching is done by applying a TTL compatible logic signal to HL pin. The three sets of gain registers can be used to adjust optical-to-electrical conversion gain for each RED, GREEN, and BLUE laser or any wavelength in a spectral range for application. The ISL58328 is a single die device that has a photo detector of 0.7mm diameter in the center of the die. Photo current signal is amplified through TIA, fine gain amplifier, and output drivers to convert from current to voltage. The output of ISL58328 can be configured to be either differential or single-ended. Gain changing according to each wavelength is done through 3-wire interface. Registers can be updated in real time while the device is in operation.

The ISL58328 operates from a single +5.0V supply. It is available in a space-saving 9 ball glass top BGA package.

### Related Literature

- [AN1356](#), "Serial Bus Specification"
- [AN1448](#), "BD/HD-DVD/DVD/CD PMIC"

### Features

- High Sensitivity from 400nm to 1000nm with Patented Technology for Improved Blue Photo Response
- Differential Voltage Output or Single-Ended Output
- Internal Output Reference or External Output Reference
- Single +5V Power Supply
- Serial Interface for Gain Calibration
- Fast Settling Time < 20ns
- Wide Signal Bandwidth > 80MHz
- Wide Signal Gain Dynamic Range > 25dB
- Low Power Consumption
- Low Output Offset < 50mV
- Small 9-Ball Optical Chip Scale Package (OCSP) (2.2mmx2.2mm)
- SPI 3-wire Serial Interface

### Applications

- Optical Power Monitoring
- Laser Based Pico-Projectors or Projection TV
- Laser Auto Power Control for Laser Based Application
- White Balance for LED Based LCoS and DLP Pico-Projectors

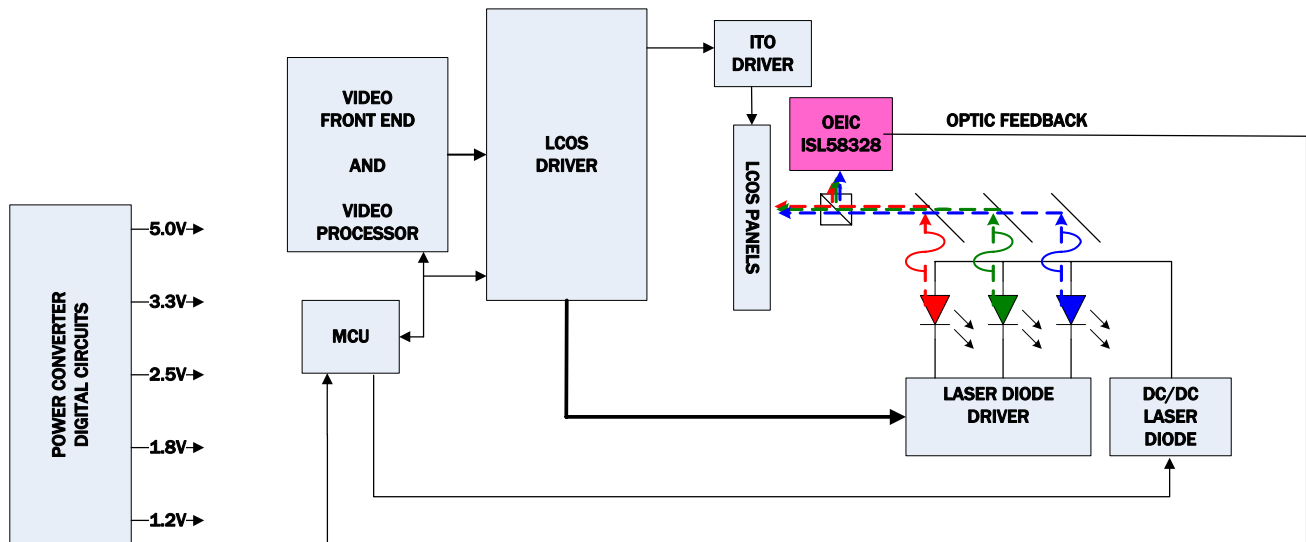

FIGURE 1. APPLICATION BLOCK DIAGRAM

For additional products, see [www.intersil.com/product\\_tree](http://www.intersil.com/product_tree)

---

Intersil products are manufactured, assembled and tested utilizing ISO9000 quality systems as noted in the quality certifications found at [www.intersil.com/design/quality](http://www.intersil.com/design/quality)

---

*Intersil products are sold by description only. Intersil Corporation reserves the right to make changes in circuit design, software and/or specifications at any time without notice. Accordingly, the reader is cautioned to verify that data sheets are current before placing orders. Information furnished by Intersil is believed to be accurate and reliable. However, no responsibility is assumed by Intersil or its subsidiaries for its use; nor for any infringements of patents or other rights of third parties which may result from its use. No license is granted by implication or otherwise under any patent or patent rights of Intersil or its subsidiaries.*

---

For information regarding Intersil Corporation and its products, see [www.intersil.com](http://www.intersil.com)