

Technical Manual

Control® 1X/1Xtreme/One



ACOUSTIC & ELECTRICAL SPECIFICATIONS:

- Nominal Impedance 8 Ohms
- Max Amp Power 80 Watts*
- Frequency Response 80Hz – 20kHz
- Sensitivity 89dB (2.83V @ 1 meter)
- Crossover Frequency 4000Hz

SYSTEM COMPONENTS:

- Cabinet Control 1X/1Xtreme/One (Not for Sale)
- Grille Black (C1004X)
Silver (C1004X-S)
- High-Frequency Transducer 1/2" (12.7mm) Titanium-laminate, shielded (C1002X)
DC Resistance 3.3 Ohms, ±10%
- Low-Frequency Transducer 4" (101.6mm) Shielded (C1003X)
DC Resistance 2.4 Ohms, ±10%
- Crossover Network (C1006X)

AURAL SWEEP TEST SPECIFICATIONS:

- System Aural Sweep Test 6.0V Input 80Hz to 20kHz
- L.F. Aural Sweep Test 5.0V Input 80Hz to 5kHz
- H.F. Aural Sweep Test 2.83V Input 3kHz to 20kHz

PHYSICAL SPECIFICATIONS:

- Enclosure Dimensions 9" x 6-1/16" x 5-7/16"
(228mm x 155mm x 139mm)
- Weight 10.4 lb/4.7kg (sold in pairs)

WARRANTY:

- Refer to Warranty Statement packed with each product.

* The maximum recommended amplifier power rating will ensure proper system headroom to allow for occasional peaks. We do not recommend sustained operation at these maximum power levels.

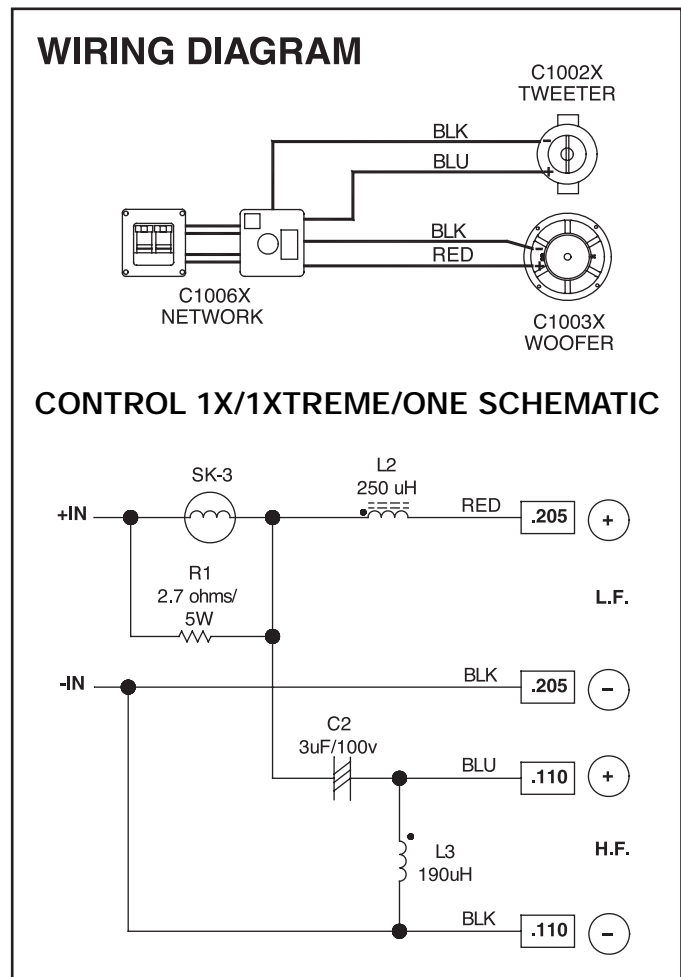
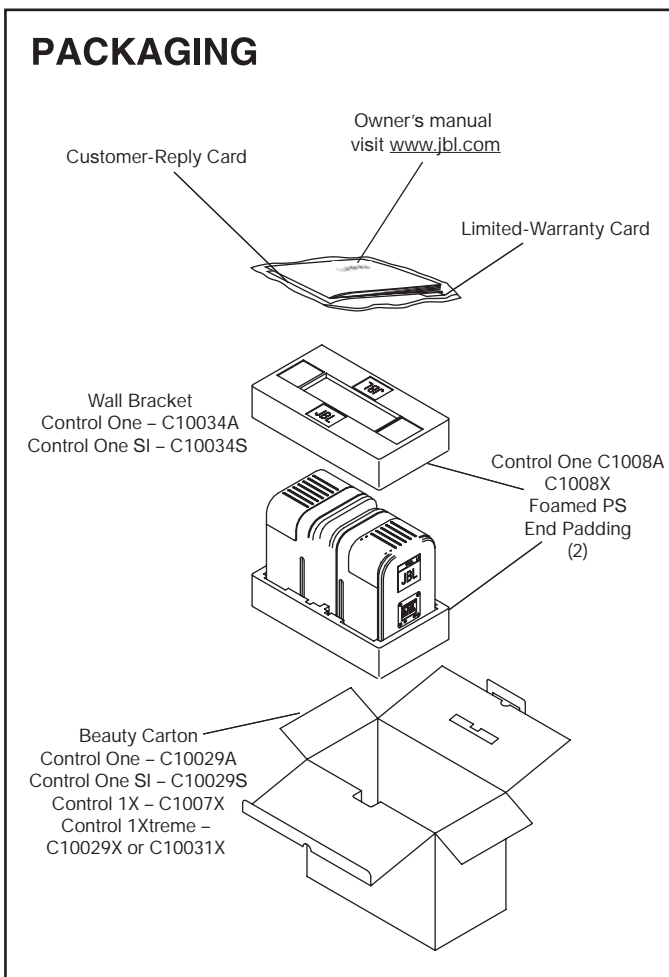

Control® 1X/1Xtreme/One

Technical Manual

Control® 1X/1Xtreme/One



EXPLODED VIEW

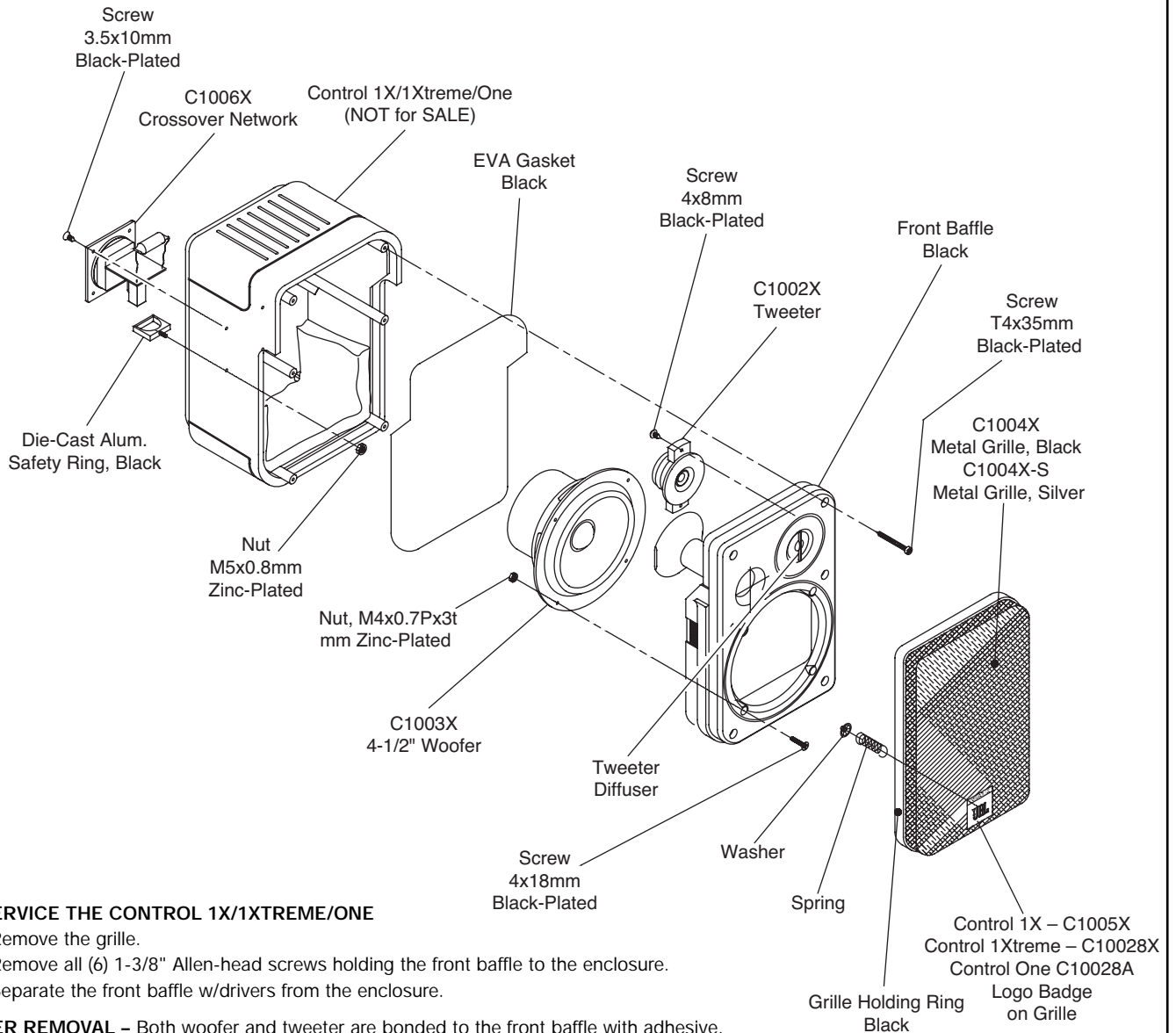

TO SERVICE THE CONTROL 1X/1XTREME/ONE

1. Remove the grille.
2. Remove all (6) 1-3/8" Allen-head screws holding the front baffle to the enclosure.
3. Separate the front baffle w/drivers from the enclosure.

DRIVER REMOVAL - Both woofer and tweeter are bonded to the front baffle with adhesive.

Unclip FASTON connectors from both woofer and tweeter.

- a) **Woofer removal:**
Remove all (4) machine screws; rear nut can be held by long-nosed pliers while screws are turned.
Apply heat gun (750°) to area around woofer basket until adhesive softens enough to extract the woofer.
- b) **Tweeter removal:**
Remove both (2) Phillips screws.
Apply heat gun (750°) to area around inside of cavity until adhesive softens enough to extract the tweeter.
After removal, take care not to lose or misplace the small clear plastic diffuser should it become dislodged.

CAUTION: Too much heat applied in one area too long could warp the front baffle.

DRIVER REPLACEMENT

Both woofer and tweeter must have a bead of adhesive applied to the outer rim only upon reassembly.
Silicone sealer or rubber-to-metal cement is recommended.

Control® 1X/1Xtreme/One