

5mm Size Hollow Shaft Type EC05E Series

Detail

Part number	EC05E1220202	
Number of detent	12	
Number of pulse	12	
Operating direction	Horizontal	
Mount height	4.5mm	
Minimum order unit (pcs.)	8,000	
Operating temperature range	-30°C to +85°C	
Maximum operating current (Resistive load)	0.55mA	
Electrical performance	Ratings	0.55mA 5V DC
	Output signal	Output of A and B signals, proportionate to phase difference
	Insulation resistance	50MΩ min. 50V DC
	Voltage proof	50V AC for 1 minute
Mechanical performance	Detent torque	1.6 ± 1.3mNm
Resistance to soldering heat	Manual soldering	350°C max. 3s max.
	Reflow soldering	Refer to soldering conditions
Durability	Operating life	100,000 cycles
Environmental performance	Cold	-40 ± 3°C for 240h
	Dry heat	85 ± 3°C for 240h
	Damp heat	40 ± 2°C, 90 to 95%RH for 240h
3D CAD (STEP)		
Certificate of Compliance to RoHS regulations		

Photo

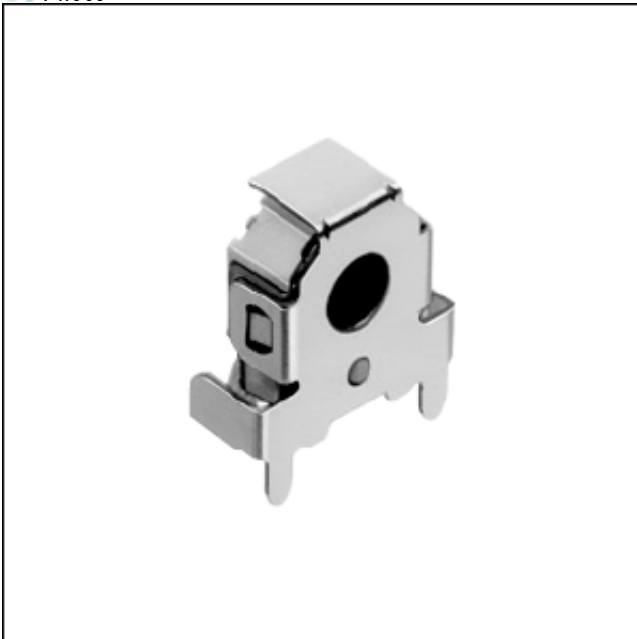

Dimensions

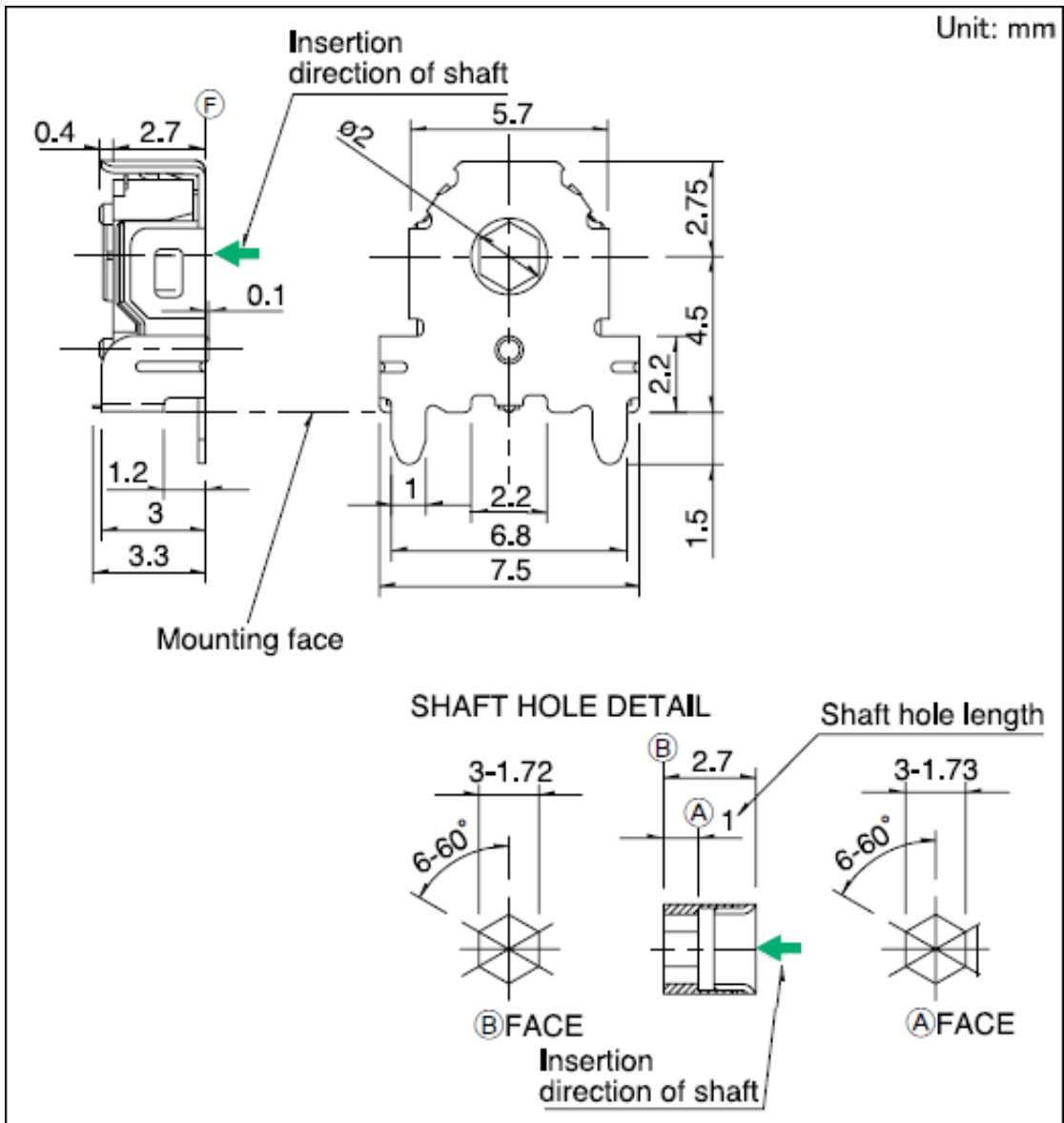

Land Dimensions

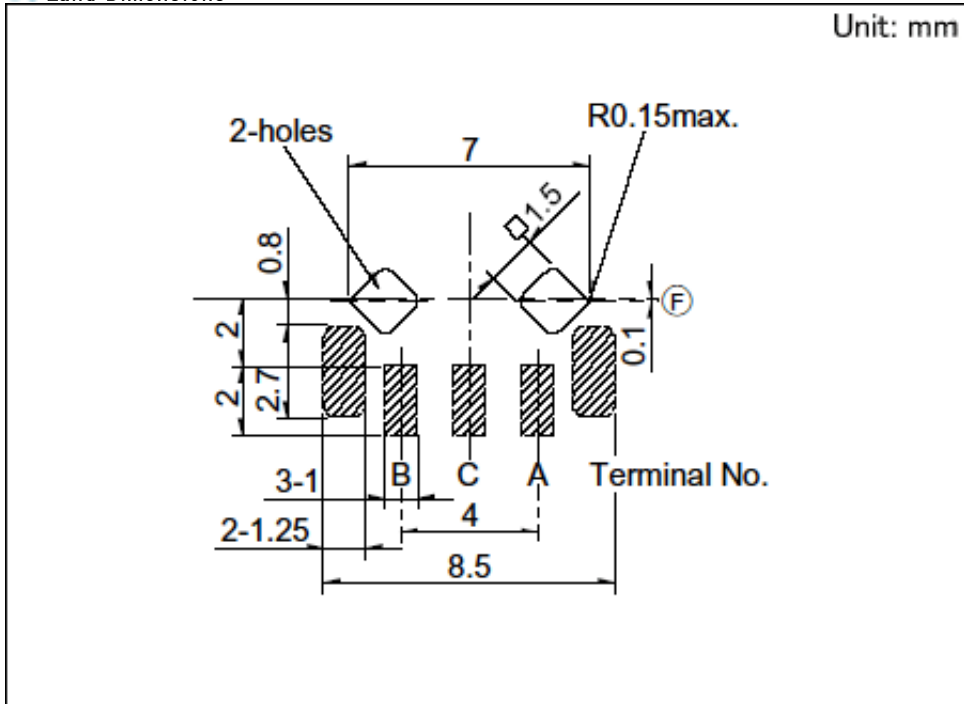

Viewed from mounting side, shaded area indicated soldering land.

●● Packing Specifications

Taping

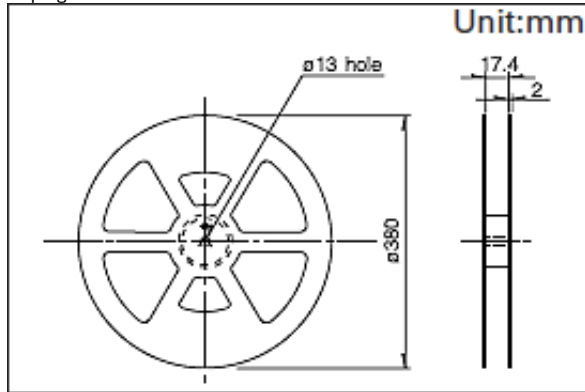

Number of packages (pcs.)	1卷	1,000
	1 case / Japan	4,000
	1 case / export packing	8,000
Tape width (mm)		16
Export package measurements (mm)		410 × 485 × 246

●● Soldering Conditions

Example of Reflow Soldering Condition

1. Heating method
Double heating method with infrared heater.
2. Temperature measurement
Thermocouple 0.1 to 0.2 Φ CA (K) or CC (T) at soldering portion (copper foil surface). A heat resisting tape should be used for fixed measurement.
3. Temperature profile
(1) The condition mentioned above is the temperature on the mounting surface of a PC board. There are cases where the PC board's temperature greatly differs from that of the switch, depending on the PC board's material, size, thickness, etc. Care should be taken to prevent the switch's surface temperature from exceeding 260°C.
(2) Soldering conditions differ depending on reflow soldering machines. Prior verification of soldering condition is highly recommended.

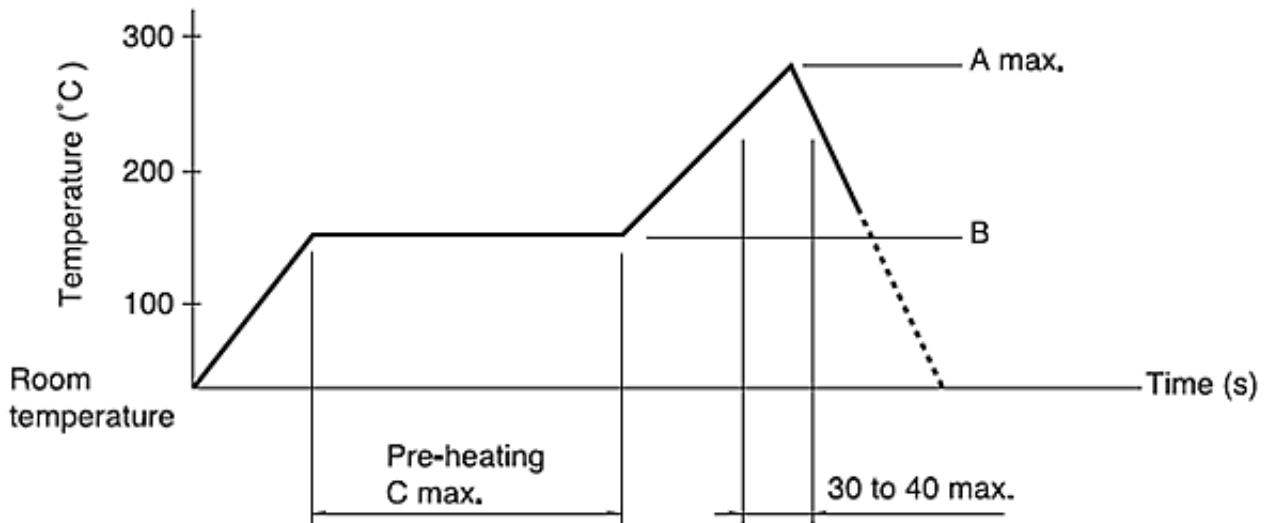

A(°C)	B(°C)	C(s)
3s max.	100max.	60以内
260		

>> NOTE

Notes are common to this series/models.

1. This site catalog shows only outline specifications. When using the products, please obtain formal specifications for supply.
2. Please place purchase orders for taping products per minimum package units (1 reel or a case). Please see taping specifications.