

DETAIL C
SCALE 1:1

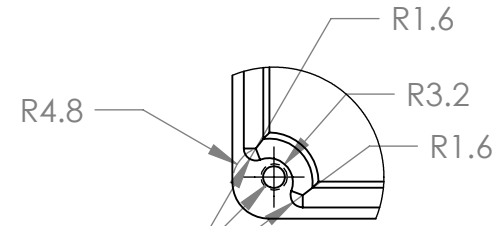

6X \varnothing 2.90 ∇ 13.80
M3.5X0.6 - 6H ∇ 12

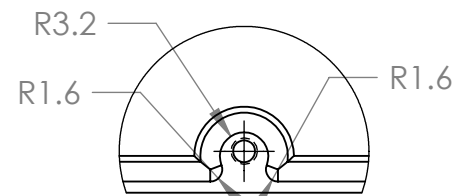
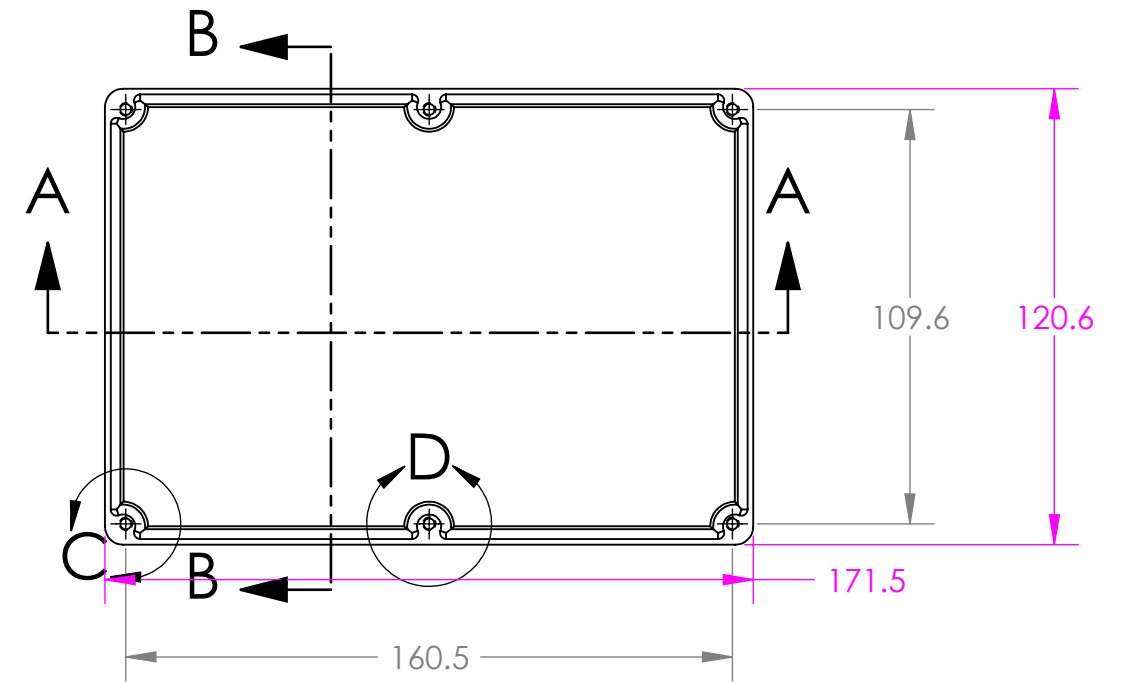

DETAIL D
SCALE 1:1

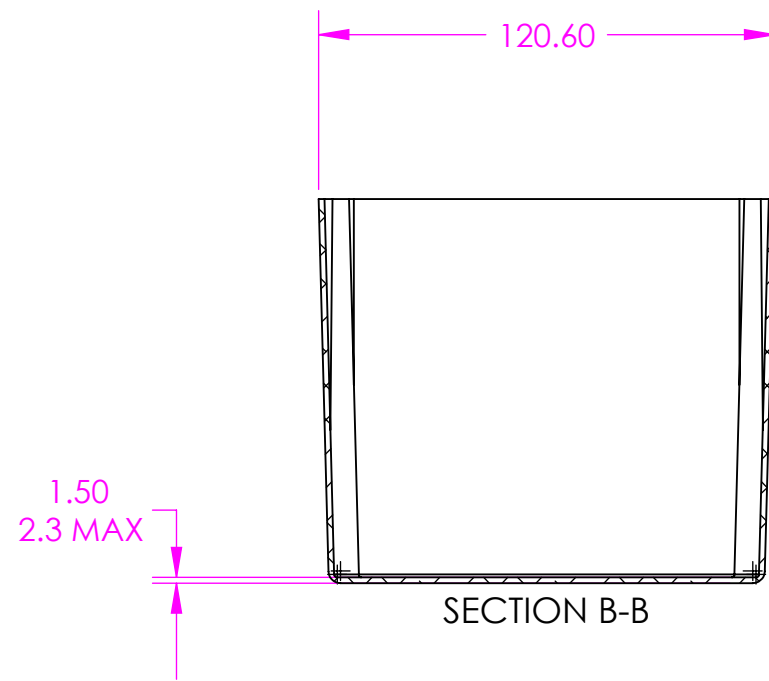

SECTION B-B

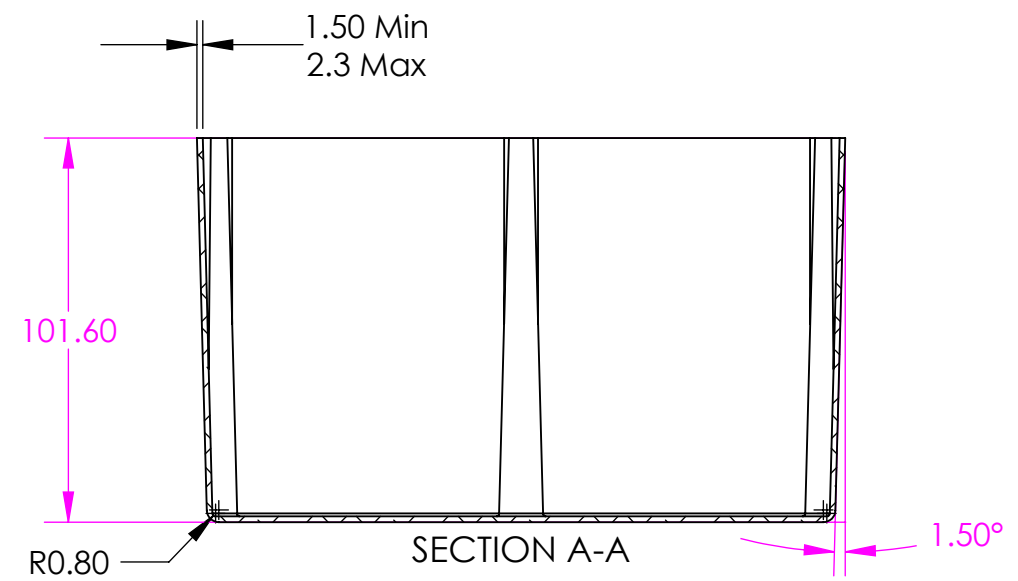

SECTION A-A

	GENERAL PURPOSE		
SIZE	PLAIN	POWDER COATED	NYLON COATED
F	459-0060	461-0060	462-0060
SEALED			
F	460-0060	453-0060	454-0060