

EAO – Your Expert Partner for
Human Machine Interfaces



EAO Configurable HMI Panel

Installation Guide and User Manual

<i>Product Name</i>	EAO Configurable HMI Panel		
<i>Revision / Date</i>	V1.00	November 1, 2010	

Record of Revisions

Revision	Description	Date	Changed by
V1.00	First release	11-1-10	D. DiGioia

Abbreviations

DIP	Dual Inline Package
DMC	DMC Co. LTD (touch screen/controller manufacturer)
HID	Human Interface Device
ID	Identification
PCB	Printed Circuit Board
RS232	Recommended Standard 232
USB	Universal Serial Bus
U-ID	Usage ID
U-Name	Usage Name

Contact Information

EAO Switch

98 Washington Street
Milford, CT 06460

Product Information and Documents: www.eao.com

For technical product support, please send an e-Mail to: sales@eaoswitch.com.

Table of Content

Record of Revisions	1
Abbreviations.....	1
Table of Content.....	2
List of Tables	2
List of Figures.....	2
Overview of variants.....	3
Keyboard Design	4
Keyboard Interface	7
USB Interface	7
Serial Interface.....	10
Port settings	10
RS232 protocol	10
Keyboard Interface settings	12
Key codes	13
Touch Screen Interface	15
Driver Installation	15
Calibration and General Touch Screen settings	15
Touch Screen Interface settings	15

List of Tables

<i>Table 1 - Keyboard Design.....</i>	<i>5</i>
<i>Table 2 - LED assignment.....</i>	<i>9</i>
<i>Table 3 - RS232 frame commands</i>	<i>10</i>
<i>Table 4 - Data frames serial communication.....</i>	<i>11</i>
<i>Table 5 - Keyboard settings</i>	<i>12</i>
<i>Table 6 - Key assignment for C-HMI.....</i>	<i>14</i>

List of Figures

Figure 1 - Keyboard Interface.....	12
Figure 2 - Key Assignment	13
Figure 3 - Saving Calibration Data	15
Figure 4 - Interface Settings : Touch Controller	16

Overview of variants

EAO offers 4 variations of the C-HMI Panel:

EUS-C-HMI-06-AGL-EK8 – 5.7” window, acrylic glass lens, no display, E-Stop, keylock, 8 discrete pushbuttons

EUS-C-HMI-06-AGLD-EK8 – 5.7” window, acrylic glass lens, with display, E-Stop, keylock, 8 discrete pushbuttons

EUS-C-HMI-06-RTS-EK8 – 5.7” window, acrylic glass lens, resistive touch screen, no display, E-Stop, keylock, 8 discrete pushbuttons

EUS-C-HMI-06-RTSD-EK8 – 5.7” window, acrylic glass lens, resistive touch screen, with display, E-Stop, keylock, 8 discrete pushbuttons

The approved Sharp display for the C-HMI Panel is: LQ057Q3DC12
QVGA/320*240, CCFT backlight

EAO #	Touch screen	Keyboard Interface ¹	Touch screen Interface ²
EUS-C-HMI-06-AGL-EK8	-	USB / RS232	
EUS-C-HMI-06-AGLD-EK8	-	USB / RS232	
EUS-C-HMI-06-RTS-EK8	5.7"	USB / RS232	USB / RS232
EUS-C-HMI-06-RTSD-EK8	5.7"	USB / RS232	USB / RS232

Table 1: Product Variation Interfaces

¹ The keyboard interface is set up via a DIP switch (see section "Keyboard Interface settings")

² The touch screen interface is set up via jumpers (see section "Touch Screen Interface settings")

Specifications

Front Panel

Overall Size: 14" x 7"/355.6 mm x 177.8 mm

Material: Polyester PVS-G on Aluminum

Printing: 2 colors, printed on the reverse

Embossing: All keys embossed

EasyLabel: Several EasyLabel slide-in pockets for individual labeling of keys

Display Window

Visible Size: 4.65" x 3.52"/118.2 mm x 89.4 mm

Material: Acrylic glass S000

Thickness: 0.08"/2.0 mm

Coating: Non-reflexing, A1

Keys

Number: 43 keys

Operations: 1 million operations/key

Pressure/key: 3 N per key on contact spring

Material: Gold on silver polymer

Resistive Touchscreen (optional)

Size: 5.7"

Type: DMC AST 057, resistive

Connector: USB

Controller: Integrated

Electrical Specifications

Voltage: 5V

Connector: USB (cable included)

EMC shielding: None

LED's: 10 LED's, yellow

User specified for auxiliary discrete pushbuttons and indicators

Mechanical Specifications

Material: Aluminum

Thickness: 0.12"/3.0 mm

Surface: Natural anodized

Mounting: 6 stud bolts FH-832-10 (UNC thread)

Emergency Stop Switch

Actuator: Maintained with twist-to-release

Contact: 1NO/1NC SM contact,

solder/plug-in terminals

Max rating: 3A/250VAC

Front protection: IP 65 as per EN IEC 60529

This device complies with:

EN IEC 60947-5-1, EN IEC 60947-5-5, and ISO 13850

Keylock

Actuator: Flush mount 2 position maintained,

Key: Removable in "A" position

Contact: 1NO/1NC SA contact,

solder/plug-in terminals

Max rating: 5A/250VAC

Front protection: IP 65

Mechanical life: 50,000 cycles of operations

Illuminated Pushbuttons

Actuator: Flush momentary action

Contact: 1NO, Max rating: 100mA/42V

Front protection: IP 65

Mechanical lifetime: > 1 million cycles of operations

Animation sequence:

Customer defined; illumination created by 8 SMT LEDs

Keyboard Design

Table 1 - Keyboard Design (see page 12 for key code output table and reference drawing)

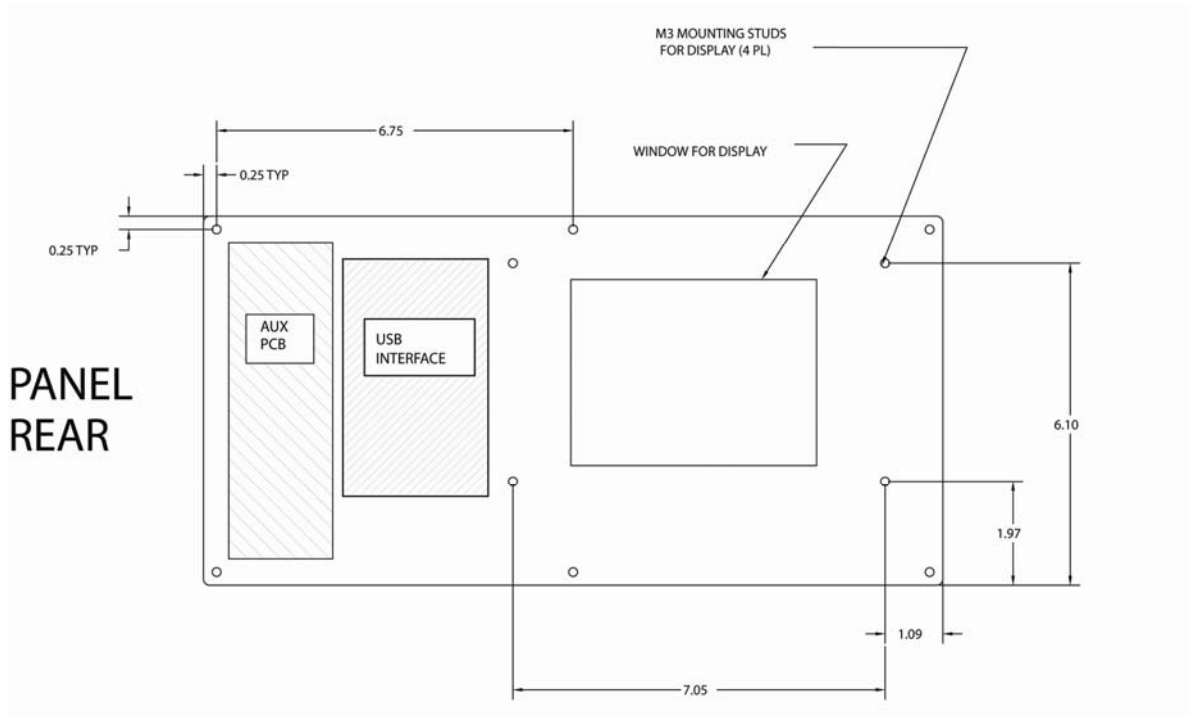
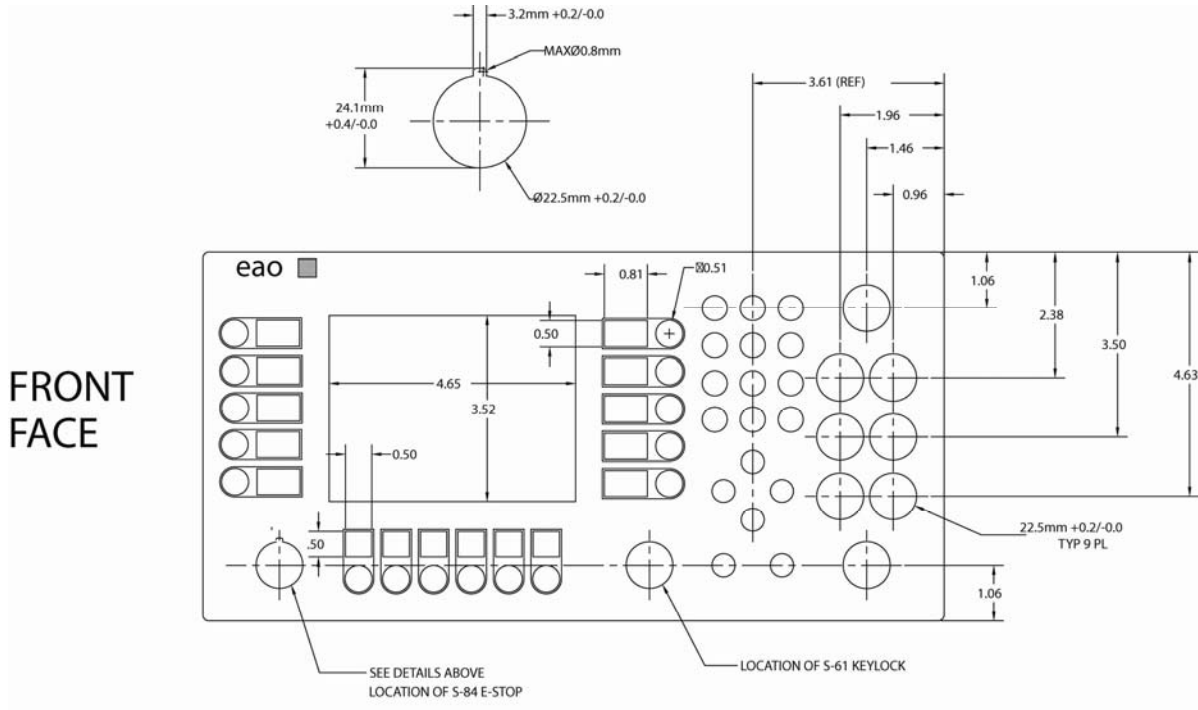

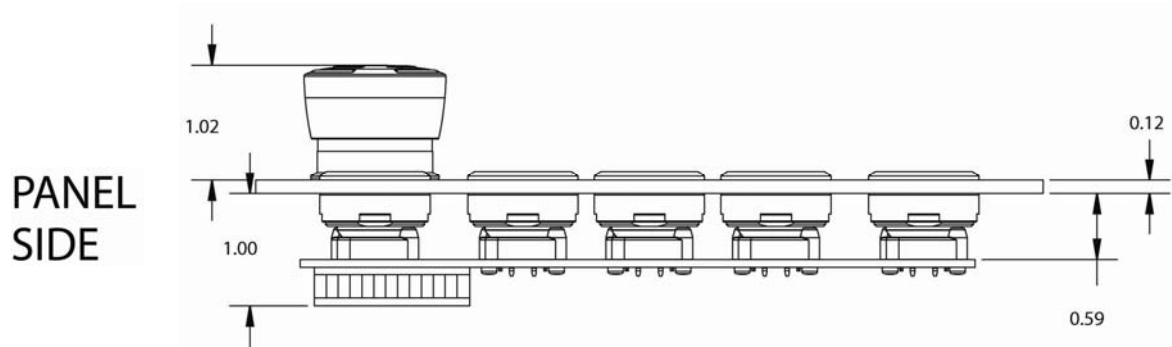

Keyboard Interface

Both variants (with and without touch screen) of each series use the same key codes. If USB is selected as keyboard interface the keyboard sends standard HID codes according to the corresponding table of each series. If serial communication is selected the same hex-values are sent for the single keys. For serial communication a special protocol is defined (see section “Serial Interface”).

USB Interface

The keyboard is a standard HID device and is configured with two interfaces (keyboard and LED).

Configuration descriptor:

Device descriptor	
bcdUSB	1.1.1
bDeviceClass	Class defined at interface level
bDeviceProtocol	None
bMaxPacketSize0	32
idVendor	0x1C80
idProduct	0x00BA
bcdDevice	1.0
iManufacturer	1
iProduct	2

Configuration descriptor	
bNumInterface	2
bConfigurationValue	1
bmAttributes. RemoteWakeup	Not supported
bmAttributes. SelfPowered	No, Bus Powered
bMaxPower	100 mA

Keyboard interface descriptor:

Interface descriptor	
bInterfaceNumber	0
bAlternateSetting	0
bNumEndpoints	1
bInterfaceClass	Human Interface Device (Find out more online)











HID descriptor	
bCountryCode	Not Supported
bNumDescriptors	1
bDescriptorType[0]	REPORT
wDescriptorLength[0]	63 bytes

Endpoint descriptor	
bEndpointAddress	1 IN
bmAttributes. TransferType	Interrupt
wMaxPacketSize	8 bytes
bInterval	16 frames (16 ms)

Keyboard report descriptor:

HID Report Descriptor	
Item	Data
Usage Page (<i>Generic Desktop</i>)	05 01
Usage (<i>Keyboard</i>)	09 06
Collection (<i>Application</i>)	A1 01
Usage Page (<i>Keyboard</i>)	05 07
Usage Minimum (<i>Keyboard Left Control</i>)	19 E0
Usage Maximum (<i>Keyboard Right GUI</i>)	29 E7
Logical minimum (<i>0</i>)	15 00
Logical maximum (<i>1</i>)	25 01
Report Size (<i>1</i>)	75 01
Report Count (<i>8</i>)	95 08
Input (<i>Data,Value,Absolute,Bit Field</i>)	81 02
Report Count (<i>1</i>)	95 01
Report Size (<i>8</i>)	75 08
Input (<i>Constant,Array,Absolute,Bit Field</i>)	81 01
Report Count (<i>5</i>)	95 05
Report Size (<i>1</i>)	75 01
Usage Page (<i>LEDs</i>)	05 08
Usage Minimum (<i>Num Lock</i>)	19 01
Usage Maximum (<i>Scroll Lock</i>)	29 03
Output (<i>Data,Value,Absolute,Non-volatile,Bit Field</i>)	91 02
Report Count (<i>1</i>)	95 01
Report Size (<i>3</i>)	75 03
Output (<i>Constant,Array,Absolute,Non-volatile,Bit Field</i>)	91 01
Report Count (<i>6</i>)	95 06
Report Size (<i>8</i>)	75 08
Logical minimum (<i>0</i>)	15 00
Logical maximum (<i>101</i>)	25 65
Usage Page (<i>Keyboard</i>)	05 07
Usage Minimum (<i>No event indicated</i>)	19 00
Usage Maximum (<i>Keyboard Application</i>)	29 65
Input (<i>Data,Array,Absolute,Bit Field</i>)	81 00
End Collection	C0

Keyboard input report:
(Num Lock, Caps Lock. Scroll Lock LED's are not used)

Input Report 0		
Bit offset	Bit count	Description
0	1	 Keyboard Left Control
1	1	 Keyboard Left Shift
2	1	 Keyboard Left Alt
3	1	 Keyboard Left GUI
4	1	 Keyboard Right Control
5	1	 Keyboard Right Shift
6	1	 Keyboard Right Alt
7	1	 Keyboard Right GUI
8	8	 (Not used)
16	8	 Keyboard Array
24	8	 Keyboard Array
32	8	 Keyboard Array
40	8	 Keyboard Array
48	8	 Keyboard Array
56	8	 Keyboard Array

LED interface descriptor:

Interface descriptor	
bInterfaceNumber	1
bAlternateSetting	0
bNumEndpoints	1
bInterfaceClass	Human Interface Device (Find out more online)

HID descriptor	
bCountryCode	Not Supported
bNumDescriptors	1
bDescriptorType[0]	REPORT
wDescriptorLength[0]	24 bytes

Endpoint descriptor	
bEndpointAddress	2 IN
bmAttributes. TransferType	Interrupt
wMaxPacketSize	2 bytes
bInterval	32 frames (32 ms)

LED report descriptor:

HID Report Descriptor	
Item	Data
Usage Page (Vendor-defined 0xFF00)	06 00 FF
Usage (Vendor-defined 0x0001)	09 01
Collection (Application)	A1 01
Usage Page (LEDs)	05 08
Usage Minimum (Num Lock)	19 01
Usage Maximum (Caps Lock)	29 02
Logical minimum (0)	15 00
Logical maximum (1)	25 01
Report Count (2)	95 02
Report Size (8)	75 08
Output (Data, Value, Absolute, Non-volatile, Bit Field)	91 02
End Collection	C0

The LED report consists of two bytes. The single LED's of the keyboard can be controlled using the assignment of Table 3. Setting a bit to "1" turns the corresponding LED on. Otherwise setting a bit to "0" turns the LED off.

	Bit7	Bit6	Bit5	Bit4	Bit3	Bit2	Bit1	Bit0
LEDByte1	H8	H7	H6	H5	H4	H3	H2	H1
LEDByte2	H16	H15	H14	H13	H12	H11	H10	H9

Table 2 - LED assignment

The LED positions on the individual keyboard can be found in the figures of the corresponding key code sections.

Serial Interface

Port settings

To communicate via serial interface, the following settings must be used for the Host COM port:

- 38.400 bytes/s
- 8 data bytes
- 1 stop bit
- no parity

RS232 protocol

For the implementation of a serial connection between the host and keyboard, the information of the keyboard protocol is necessary. First, an overview of commands is given. Subsequently, the structure of the data frames and control sequences is defined.

Command definitions

Command	Dec	Hex	Description
START_HOST	170	AA	Start of frame (from Host)
START_CONTROLLER	171	AB	Start of frame (from μ C)
END_IDENTIFIER	204	CC	End of frame (both Host+ μ C)
ACK	240	F0	Acknowledgement
ERROR	242	F2	Error in data frame
CODE_UNKNOWN	243	F3	Unknown command
CODE_LEDi	176	B0	Set LED status
CODE_LED _o	177	B1	Get LED Status

Table 3 - RS232 frame commands

Data frame definition

Within the host/keyboard protocol the following data frames are defined (see *Table 4*). The assignment of the LED's is the same as for the USB protocol and can be found in

Table 2. The key codes (hex values) are also the same as the Usage ID's for the HID keyboard report

Byte sequence set LED status						
Host request	START_HOST	CODE_LEDi	LEDByte1	LEDByte2	END IDENTIFIER	
Keyboard response	START_CONTROLLER	CODE_LEDi	LEDByte1	LEDByte2	END IDENTIFIER	
Byte sequence get LED status						
Host request	START_HOST	CODE_LED0	END IDENTIFIER			
Keyboard response	START_CONTROLLER	CODE_LED0	LEDByte1	LEDByte2	END IDENTIFIER	
Messages of keyboard controller						
Error in frame	START_CONTROLLER	ERROR	mirror received bytes	END IDENTIFIER		
Unknown command	START_CONTROLLER	CODE UNKNOWN	mirror command	END IDENTIFIER		
Data frame keyboard						
Byte sequence key codes	START_CONTROLLER	Modifier Byte	Key code byte1	Key code byte2	Key code byte3	END IDENTIFIER

Table 4 - Data frames serial communication

Keyboard Interface settings³

For the keyboard interface, different settings are available. Settings can be changed via the DIP switch (see Figure 1). To change settings, disconnect the keyboard from the host and set the switches according to table 6. Reconnect the key board to the host for the new settings to take effect.

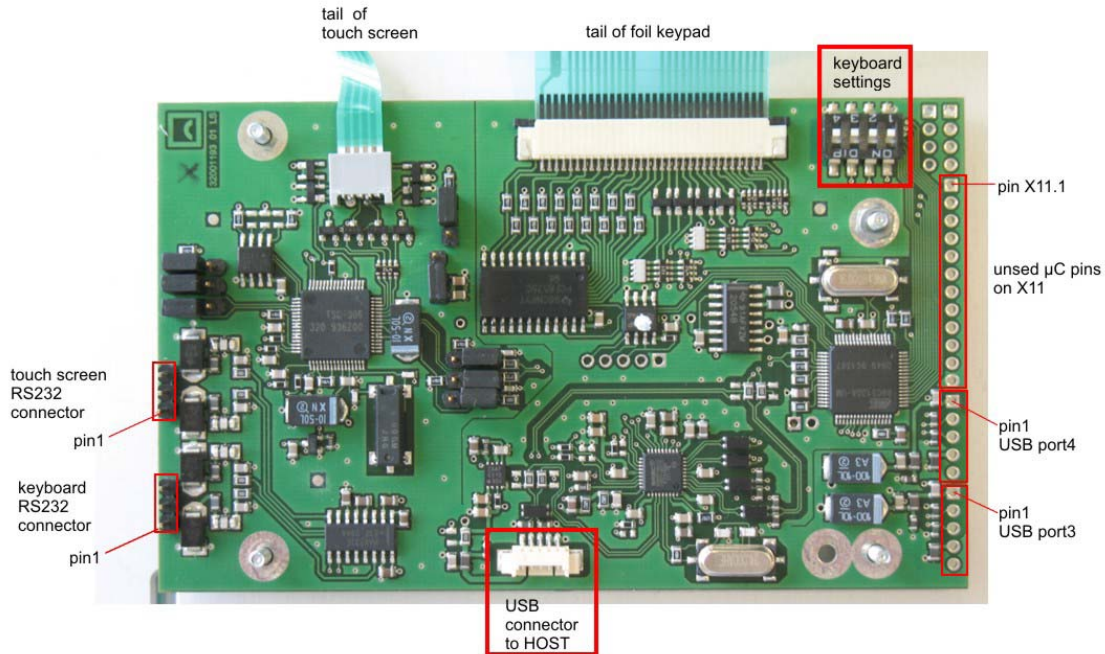
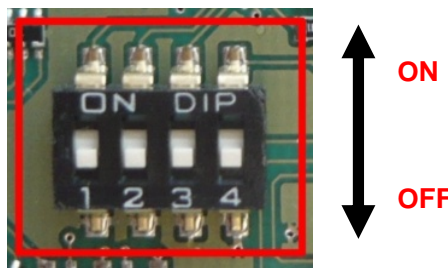

Figure 1 - Keyboard interface

PLEASE NOTE: The figure shows the PCB of the keyboards with an integrated touch screen. The PCB of the keyboards without a touch screen is the same but not all SMD components shown in the figure are mounted!

By default all switches are **off**.



DIP switch No.	ON	OFF
1	RS232 communication	USB communication (default)
2	Standard key assignment with 2 nd layer activated	Standard key assignment (default)
3	-	-
4	-	-

Table 5 - Keyboard settings

³ These settings are available for all OPAL keyboards

Key codes for C-HMI

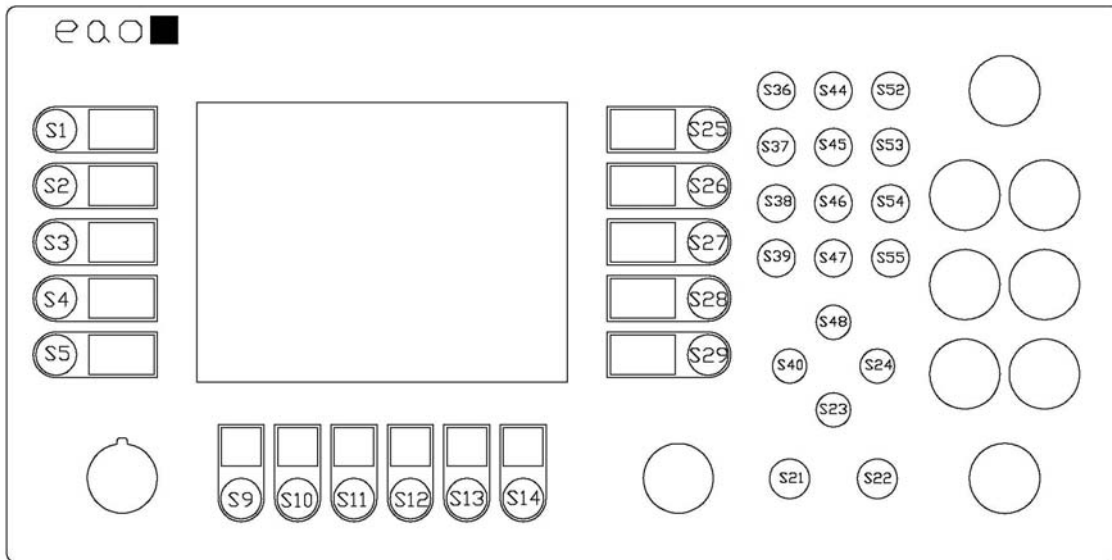

Figure 2 – Key codes for C-HMI (see page 5 for panel dimensions)

Key Position	Usage ID (dec/hex)		Usage Name	Modifier Byte	Key Label
S1	4	04	Keyboard a and A	0x02	S1 (+ Module)
S2	5	05	Keyboard b and B	0x02	S2 (+ Module)
S3	6	06	Keyboard c and C	0x02	S3 (+ Module)
S4	7	07	Keyboard d and D	0x02	S4 (+ Module)
S5	8	08	Keyboard e and E	0x02	S5 (+ Module)
S9	58	3A	Keyboard F1		F1
S10	59	3B	Keyboard F2		F2
S11	60	3C	Keyboard F3		F3
S12	61	3D	Keyboard F4		F4
S13	62	3E	Keyboard F5		F5
S14	63	3F	Keyboard F6		F6
S21	41	29	Keyboard Escape		Esc
S22	40	28	Keyboard Return (ENTER)		Enter
S23	81	51	Keyboard Down Arrow		↓
S24	79	4F	Keyboard Right Arrow		→
S25	9	09	Keyboard f and F	0x02	S6 (+ Module)
S26	10	0A	Keyboard g and G	0x02	S7 (+ Module)
S27	11	0B	Keyboard h and H	0x02	S8 (+ Module)
S28	12	0C	Keyboard i and I	0x02	S9 (+ Module)
S29	13	0D	Keyboard j and J	0x02	S10 (+ Module)
S36	36	24	Keyboard 7 and &		7 (abc)
S37	33	21	Keyboard 4 and \$		4 (jkl)
S38	30	1E	Keyboard 1 and !		1 (stu)
S39	39	27	Keyboard 0 and)		0 (_)
S40	80	50	Keyboard Left Arrow		←
S44	37	25	Keyboard 8 and *		8 (def)
S45	34	22	Keyboard 5 and %		5 (mno)
S46	31	1F	Keyboard 2 and @		2 (vwX)
S47	55	37	Keyboard . and >		.
S48	82	52	Keyboard Up Arrow		↑
S52	38	25	Keyboard 9 and (9 (ghi)
S53	35	23	Keyboard 6 and ^		6 (pqr)
S54	32	20	Keyboard 3 and #		3 (yz)
S55	54	36	Keyboard , and <		,

Table 6 - Key assignment for C-HMI

Touch Screen Interface⁴

To operate the touch screen, the analog resistive touch screen controller TSC-30/IC from DMC is used.

Driver Installation

Before the touch screen can be used the TSC-10/DD driver from DMC must be installed onto the system. The actual driver can be downloaded from the download section of the DMC website (<http://www.dmccoltd.com/english/>). Please follow the instructions of the installation manual of DMC.

Upon successful installation, the driver can be found in the Windows device manager (“Mice and other pointing devices”) after plugging the EAO keyboard to the Host (via USB).

Calibration and general Touch Screen settings

To calibrate the touch screen, the UPDD console (installed during driver installation) from DMC can be used. Please refer to the DMC documentation for calibration and setting details. The EAO keyboard can save the calibration data. In order to do so (and before calibrating the touch screen), the appropriate check box must be activated.

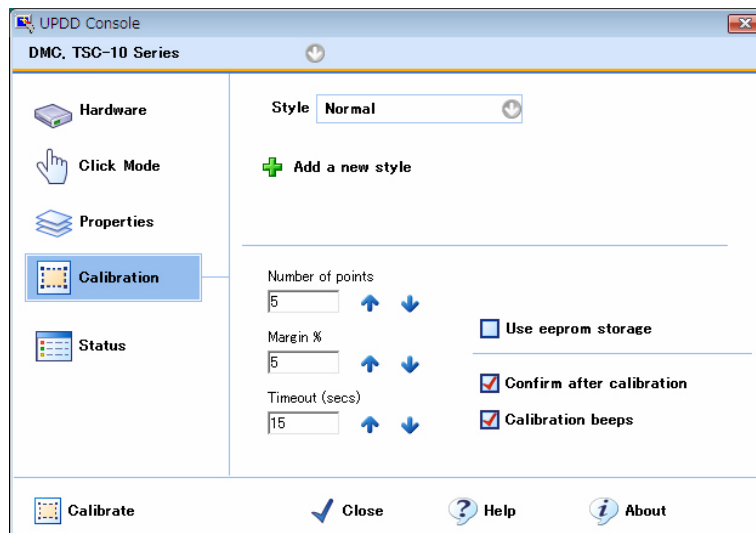

Figure 3 - Saving the calibration data

Touch Screen Interface settings

For the touch screen interface, two settings (USB/RS232 communication) are available. Settings can be changed via the jumpers on the right side of the PCB (see Figure 4). To change settings, disconnect the keyboard from the Host and set the jumper as desired. Reconnect the keyboard to the host for new settings to take effect.



Remember to connect the keyboard to the host with the appropriate cable according to the chosen interface! It is important to change all jumpers according to the desired setting. Otherwise the keyboard will not operate.

⁴ These settings are only available for OPAL keyboards with integrated touch screen.

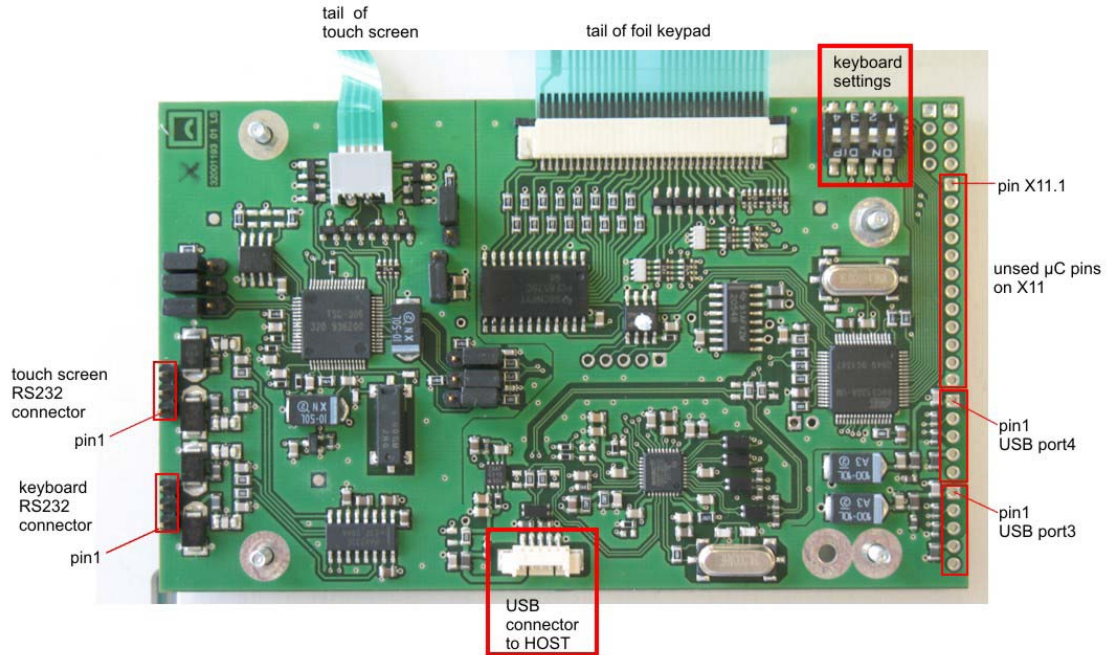

Figure 4 - Interface settings touch controller

By default, the USB interface is activated (see jumper position of *Figure 4*). To activate the RS232 interface, change the position of **all** jumpers so that the middle and the lower pin of **every** connector in the blue box are bypassed.