

---

# 1322x USB Dongle

## Reference Manual

Document Number: 1322xUSBRM  
Rev. 1.5  
11/2010



**How to Reach Us:**

**Home Page:**  
www.freescale.com

**E-mail:**  
support@freescale.com

**USA/Europe or Locations Not Listed:**  
Freescale Semiconductor  
Technical Information Center, CH370  
1300 N. Alma School Road  
Chandler, Arizona 85224  
+1-800-521-6274 or +1-480-768-2130  
support@freescale.com

**Europe, Middle East, and Africa:**  
Freescale Halbleiter Deutschland GmbH  
Technical Information Center  
Schatzbogen 7  
81829 Muenchen, Germany  
+44 1296 380 456 (English)  
+46 8 52200080 (English)  
+49 89 92103 559 (German)  
+33 1 69 35 48 48 (French)  
support@freescale.com

**Japan:**  
Freescale Semiconductor Japan Ltd.  
Headquarters  
ARCO Tower 15F  
1-8-1, Shimo-Meguro, Meguro-ku,  
Tokyo 153-0064, Japan  
0120 191014 or +81 3 5437 9125  
support.japan@freescale.com

**Asia/Pacific:**  
Freescale Semiconductor Hong Kong Ltd.  
Technical Information Center  
2 Dai King Street  
Tai Po Industrial Estate  
Tai Po, N.T., Hong Kong  
+800 2666 8080  
support.asia@freescale.com

**For Literature Requests Only:**  
Freescale Semiconductor Literature Distribution Center  
P.O. Box 5405  
Denver, Colorado 80217  
1-800-521-6274 or 303-675-2140  
Fax: 303-675-2150  
LDCForFreescaleSemiconductor@hibbertgroup.com

Information in this document is provided solely to enable system and software implementers to use Freescale Semiconductor products. There are no express or implied copyright licenses granted hereunder to design or fabricate any integrated circuits or integrated circuits based on the information in this document.

Freescale Semiconductor reserves the right to make changes without further notice to any products herein. Freescale Semiconductor makes no warranty, representation or guarantee regarding the suitability of its products for any particular purpose, nor does Freescale Semiconductor assume any liability arising out of the application or use of any product or circuit, and specifically disclaims any and all liability, including without limitation consequential or incidental damages. "Typical" parameters that may be provided in Freescale Semiconductor data sheets and/or specifications can and do vary in different applications and actual performance may vary over time. All operating parameters, including "Typicals", must be validated for each customer application by customer's technical experts. Freescale Semiconductor does not convey any license under its patent rights nor the rights of others. Freescale Semiconductor products are not designed, intended, or authorized for use as components in systems intended for surgical implant into the body, or other applications intended to support or sustain life, or for any other application in which the failure of the Freescale Semiconductor product could create a situation where personal injury or death may occur. Should Buyer purchase or use Freescale Semiconductor products for any such unintended or unauthorized application, Buyer shall indemnify and hold Freescale Semiconductor and its officers, employees, subsidiaries, affiliates, and distributors harmless against all claims, costs, damages, and expenses, and reasonable attorney fees arising out of, directly or indirectly, any claim of personal injury or death associated with such unintended or unauthorized use, even if such claim alleges that Freescale Semiconductor was negligent regarding the design or manufacture of the part.

ARM is the registered trademark of ARM Limited. ARM7TDMI-S is the trademark of ARM Limited.

Freescale™ and the Freescale logo are trademarks of Freescale Semiconductor, Inc. All other product or service names are the property of their respective owners.

© Freescale Semiconductor, Inc. 2005, 2006, 2007, 2008, 2009, 2010. All rights reserved.

# Contents

---

## About This Book

Audience . . . . .	iii
Organization . . . . .	iii
Revision History . . . . .	iii

## Chapter 1 Safety Information

1.1	FCC Guidelines. . . . .	1-1
1.2	FCC Labeling . . . . .	1-1
1.2.1	47 C.F.R. Sec. 15.21 . . . . .	1-1
1.2.2	47 C.F.R. Sec.15.105(b) . . . . .	1-2
1.2.3	47 C.F.R. Sec.15.203 . . . . .	1-2
1.3	Regulatory Approval For Canada . . . . .	1-2
1.4	Disposal Instructions. . . . .	1-2

## Chapter 2 1322x USB Dongle Overview

2.1	Introduction. . . . .	2-1
2.2	Available Devices . . . . .	2-2
2.3	Features. . . . .	2-2
2.4	Driver Considerations . . . . .	2-3
2.5	Board Level Specifications . . . . .	2-3

## Chapter 3 System Overview and Functional Descriptions

3.1	System Block Diagram . . . . .	3-1
3.2	System Overview . . . . .	3-1
3.3	Power Source . . . . .	3-3
3.4	Low-cost 2.4 GHz ISM Band radio . . . . .	3-4
3.5	USB Interface . . . . .	3-4
3.6	Clock. . . . .	3-5
3.7	Reset Switch and LEDs . . . . .	3-5
3.8	FLASH Memory Recovery Jumpers and Erase . . . . .	3-5
3.9	Optional Debug/Development Interface (ARM JTAG Interface) . . . . .	3-6

## Chapter 4 Schematic, Board Layout, and Bill of Materials

## Chapter 5 PCB Manufacturing Specifications

5.1	Single PCB Construction . . . . .	5-1
5.2	Panelization. . . . .	5-2

---

5.3	Materials . . . . .	5-3
5.4	Solder Mask . . . . .	5-3
5.5	Silk Screen . . . . .	5-3
5.6	Electrical PCB Testing . . . . .	5-3
5.7	Packaging . . . . .	5-3
5.8	Hole Specification/Tool Table . . . . .	5-4
5.9	File Description. . . . .	5-4

## About This Book

This manual describes the Freescale 1322x USB Dongle, which is an IEEE 802.15.4 compliant wireless node based on the Freescale MC1322x device. The 1322x USB Dongle provides a platform to evaluate the MC1322x device, develop software and applications, and demonstrate IEEE 802.15.4 and ZigBee networking capabilities.

## Audience

This manual is intended for system designers.

## Organization

This document is organized into five chapters.

- Chapter 1            Safety Information — Highlights some of the FCC requirements.
- Chapter 2            1322x USB Dongle Overview — Introduces the 1322x USB Dongle, which is an IEEE 802.15.4 compliant wireless node based on the Freescale MC1322X device.
- Chapter 3            System Overview and Functional Descriptions — Provides an overview of the 1322x USB Dongle and its connections.
- Chapter 4            Schematic and Bill of Material — Provides the schematic, board layout, and Bill of Materials.
- Chapter 5            PCB Manufacturing Specifications — This chapter provides the specifications used to manufacture the 1322x USB Dongle printed circuit board (PCB).

## Revision History

The following table summarizes revisions to this document since the previous release (Rev 1.4).

**Revision History**

<b>Location</b>	<b>Revision</b>
Chapter 2 Chapter 3	Added dimensions to photos.

## Definitions, Acronyms, and Abbreviations

The following list defines the acronyms and abbreviations used in this document.

ADC	Analog to Digital Converter
AES	Advanced Encryption Standard
ARM	Advanced RISC Machine
CTS	Clear to Send
DAC	Digital to Analog Converter
DMA	Direct Memory Access
I2C	Inter-Integrated Circuit is a multi-master serial computer bus
ISM	Industrial Scientific Medical 2.4 GHz radio frequency band
JTAG	Joint Test Action Group
LGA	Land Grid Array
MAC	Media Access Controller
MCU	Microcontroller Unit
NEXUS	An embedded processor development tool interface that helps design engineers identify software and hardware-level issues.
SN	Sensor Node
pcb	Printed circuit board
PiP	Platform in Package
PWM	Pulse-width modulation
RTS	Request to Send
SMA Connector	SubMiniature version “A” connector
SPI	Serial Peripheral Interface
SSI	Synchronous Serial Interface
TACT Switch	A switch that provides a slight “snap” or “click” to the user to indicate function.
TELCO	Telephone Company
USB	Universal Serial Bus
VCP	Virtual Com Port

# Chapter 1

## Safety Information

### 1.1 FCC Guidelines

This equipment is for use by developers for evaluation purposes only and must not be incorporated into any other device or system. This device may not be sold to the general public. Integrators will be responsible for reevaluating the end product (including the transmitter) and obtaining a separate FCC authorization.

FCC approval of this device only covers the original configuration of this device as supplied. Any modifications to this product, including changes shown in this manual, may violate the rules of the Federal Communications Commission and Industry Canada and make operation of the product unlawful.

### 1.2 FCC Labeling

FCC labels are physically located on the plastic housing.

#### 1.2.1 47 C.F.R. Sec. 15.21

This equipment has been tested and found to comply with the limits for a Class B digital device, pursuant to part 15 of the FCC Rules. These limits are designed to provide reasonable protection against harmful interference in a residential installation. This equipment generates, uses and can radiate radio frequency energy and, if not installed and used in accordance with the instructions, may cause harmful interference to radio communications. However, there is no guarantee that interference will not occur in a particular installation. If this equipment does cause harmful interference to radio or television reception, which can be determined by turning the equipment off and on, the user is encouraged to try to correct the interference by one or more of the following measures:

- Reorient or relocate the receiving antenna.
- Increase the separation between the equipment and receiver.
- Connect the equipment into an outlet on a circuit different from that to which the receiver is connected.
- Consult the dealer or an experienced radio/TV technician for help.

### **1.2.2 47 C.F.R. Sec.15.105(b)**

This equipment complies with FCC radiation exposure limits set forth for an uncontrolled environment. The antenna(s) used for this equipment must be installed to provide a separation distance of at least 8 inches (20cm) from all persons.

This device complies with Part 15 of the FCC Rules. Operation is subject to the following three conditions:

1. This device may not cause harmful interference.
2. This device must accept any interference received, including interference that may cause undesired operation.
3. This device is susceptible to electrostatic discharge (ESD) and surge phenomenon.

### **1.2.3 47 C.F.R. Sec.15.203**

An intentional radiator shall be designed to ensure that no antenna other than that furnished by the responsible party shall be used with the device. The use of a permanently attached antenna or of an antenna that uses a unique coupling to the intentional radiator shall be considered sufficient to comply with the provisions of this Section. The manufacturer may design the unit so that a broken antenna can be replaced by the user, but the use of a standard antenna jack or electrical connector is prohibited. This requirement does not apply to carrier current devices or to devices operated under the provisions of Sections 15.211, 15.213, 15.217, 15.219, or 15.221. Further, this requirement does not apply to intentional radiators that must be professionally installed, such as perimeter protection systems and some field disturbance sensors, or to other intentional radiators which, in accordance with Section 15.31(d), must be measured at the installation site. However, the installer shall be responsible for ensuring that the proper antenna is employed so that the limits in this Part are not exceeded.

## **1.3 Regulatory Approval For Canada**

This Class B digital apparatus complies with Canadian ICES-003 and RSS 210, Issue 7.

Cet appareil numérique de la classe B est conforme à la norme NMB-003 du Canada.

## **1.4 Disposal Instructions**

This product may be subject to special disposal requirements. For product disposal instructions, refer to [www.freescale.com/productdisposal](http://www.freescale.com/productdisposal).



## Chapter 2

# 1322x USB Dongle Overview

### 2.1 Introduction

The 1322x USB Dongle is an IEEE 802.15.4 compliant wireless node based on the Freescale MC1322x device. The heart of the 1322x USB module is Freescale’s MC1322x 99-pin LGA Platform-in-Package (PiP) solution that can be used for wireless applications ranging from simple proprietary point-to-point connectivity to complete ZigBee mesh networking. The MC1322x is designed to provide a highly integrated, total solution, with premier processing capabilities and very low power consumption.

The 1322x USB Dongle provides a platform to evaluate the MC1322x device, develop software and applications, and demonstrate IEEE 802.15.4 and ZigBee networking capabilities. The dongle connects the core device to a personal computer (PC) through a USB port, UART port interface device. The small form factor illustrates an extremely small footprint, 4-layer printed circuit board (PCB) layout with a chip antenna. The MC1322x node typically interfaces to the PC through a virtual COM port (VCM).

As initially provided from Freescale, the dongle is loaded with a software application that implements a wireless “sniffer” to monitor over-the-air IEEE 802.15.4 traffic.

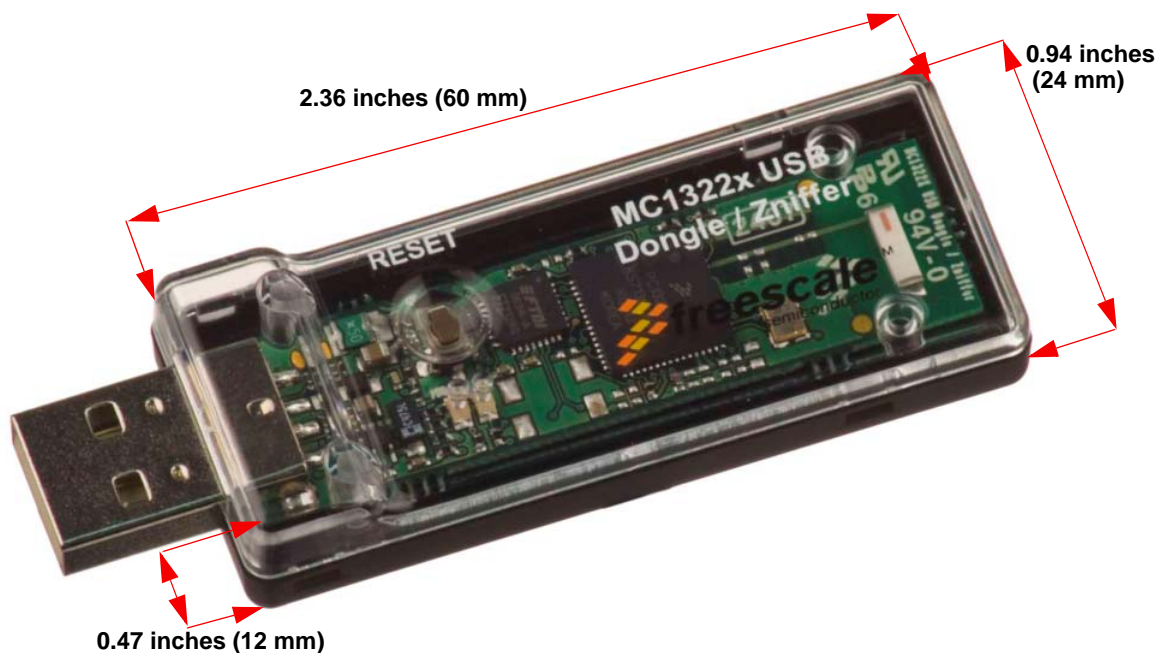

Figure 2-1. 1322x USB Dongle Top View

## 2.2 Available Devices

The MC1322x family is available as two part numbers. These device types differ only in their ROM contents, all other device hardware, performance, and specifications are identical:

- MC13224V - this is the original version and is the generic part type. It is intended for most IEEE 802.15.4 applications including MAC-based, ZigBee-2007 Profile 1, and ZigBee RF4CE targets.
- MC13226V - this is a more recent version and is intended specifically for ZigBee-2007 Profile 2 (Pro) applications. Only the onboard ROM image has been changed to optimize ROM usage for the ZigBee Pro profile and maximize the amount of available RAM for application use -
  - The IEEE MAC/PHY functionality has been streamlined to include only that functionality required by the ZigBee specification. The MAC functionality is 802.15.4 compatible.
  - Certain drivers present in the MC13224 ROM have been removed including the ADC, LCD\_font, and SSI drivers. These drivers are still available as library functions, but now compile into the RAM space.
  - The Low Level Component (LLC) functionality has also been streamlined for the ZigBee specification

### NOTE

The MC13226 USB dongles will be marked as MC13226 USB.

## 2.3 Features

The 1322x USB Dongle provides the following features:

- Full IEEE 802.15.4 compliant wireless node; ZigBee capable with Freescale's BeeStack software stack
- Based on Freescale's third-generation MC1322x ZigBee platform which incorporates a complete, low power, 2.4 GHz radio frequency transceiver, 32-bit ARM7 core based MCU, hardware acceleration for both the IEEE 802.15.4 MAC and AES security, and a full set of MCU peripherals into a 99-pin LGA Platform-in-Package (PiP)
- MC1322x provides a highly integrated, low cost RF node
  - On-board balun and antenna switch in package
  - Typical -95 dBm sensitivity
  - Typical 0 dBm output power, with max approximately +4 dBm
  - Chip antenna
- Powered from USB interface with power-on green LED
- USB interface is full-speed compatible to the USB 2.0 and 1.1 specifications
- 20-pin site for standard JTAG debug/development interface connector
- Programmable user red LED for application purposes
- Reset switch
- Default 24 MHz crystal reference oscillator

## 2.4 Driver Considerations

When users first plug a 1322x USB Dongle into the system, they may be prompted to install drivers. If BeeKit is installed and this occurs, do not allow Windows to automatically search for and install the drivers. Instead, select manual installation and steer Windows to the following directory:

C:\Program Files\Freescale\Drivers

If installing the BeeKit software package to another drive or directory, indicate the Drivers directory created by the installer in the custom location where BeeKit was installed.

Follow the instructions as they appear on the screen to complete driver installation.

If BeeKit is not installed, be aware of the following:

- The 1322x USB Dongle uses the FTDI serial to USB converter, Virtual COM Port (VCP) driver for Windows, available at [www.ftdichip.com/ftdrivers.htm](http://www.ftdichip.com/ftdrivers.htm). (Direct (D2XX) drivers are also available.)
- The FTDI web site offers drivers for other platforms including Windows® (98 through Vista x64 and CE), MAC OS (8 through X) and Linux.
- Download the appropriate driver and follow the instructions to complete driver installation.

## 2.5 Board Level Specifications

Table 2-1. 1322x USB Dongle Specifications

Parameter				Units	Notes/Conditions
	MIN	TYP	MAX		
<b>General</b>					
Size (Enclosure: X, Y, Z)			60x24x12	mm	
Size (PCB: X, Y)			55 x 15 2.165 x 0.590	mm inches	
Layer build (PCB)		0.8 0.032		mm inches	4-Layer
Dielectric material (PCB)					FR4
<b>Power</b>					
Voltage supply (USB)	4.4	5	5.25	V	USB 2.0/1.1 standard specification
Current consumption		35		mA	
<b>Temperature</b>					
Operating temperature (see note)	-30	+25	+70	°C	Operating temperature is limited to +70 °C due to switches. Basic circuit is good for a maximum temperature of +85 °C.
Storage temperature	-30	+25	+70	°C	
<b>USB interface</b>					USB 2.0 and 1.1 full-speed compatible
<b>RF</b>					

Table 2-1. 1322x USB Dongle Specifications (continued)

Parameter				Units	Notes/Conditions
802.15.4 Frequency range	2405		2480	MHz	All 16 channels in the 2450 MHz band
Range (outdoor / line of sight)		300		Meters	<1% PER for 20-byte packets (point-to-point in communications with 1322X Sensor Reference Board)
<b>RF Transmitter</b>					
802.15.4 Output power	-30	0	+4	dBm	Over range of Pout from IC control in 2 dB steps. <b>Note:</b> On channel 26, output power should not exceed -4 dBm (power setting 0x0E) to meet FCC Part 15 requirements.
Harmonics 2 <sup>nd</sup> harmonics 3 <sup>rd</sup> harmonics			-38 -35	dBm dBm	Harmonics are compliant to ETSI and FCC regulatory approval standards
<b>RF Receiver</b>					
802.15.4 sensitivity		-95		dBm	<1% PER for 20-byte packets
<b>Regulatory Approval</b>					
FCC					Product is approved accordingly to the FCC part 15 standard
CE (ETSI)					Product is approved accordingly to the EN 300 328 V1.7.1 (2006-10) standard
CE (EMC)					Product is approved accordingly to the EN 301 489-1 V1.6.1 (2005-09) and EN 301 489-17 V1.2.1 (2002-08) standards
<b>Safety</b>					
UL					Product is approved accordingly to the IEC 60950-1 and EN 60950-1, First Edition standards
<b>Environment</b>					
RoHS					Product complies with the EU Directive 2002/95/EC of 27 January 2003
WEEE					Product complies with the EU Directive 2002/95/EC of 27 January 2003

## Chapter 3

# System Overview and Functional Descriptions

This section provides an overview of the 1322x USB Dongle and its connections.

### 3.1 System Block Diagram

The following is the 1322x USB Dongle system level block diagram.

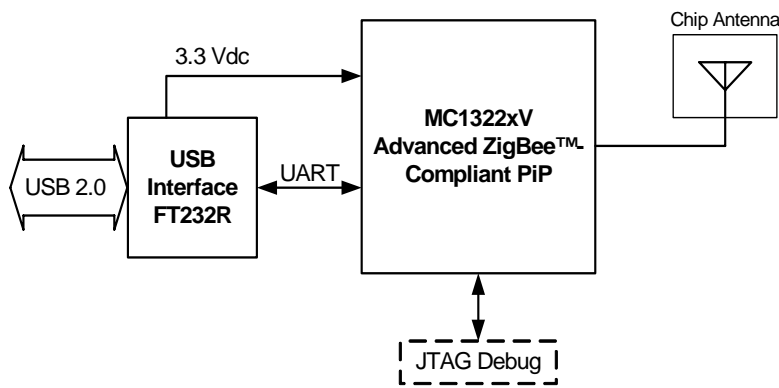

Figure 3-1. 1322x USB Dongle Block Diagram

### 3.2 System Overview

The heart of the 1322x USB Dongle is Freescale's MC1322x 99-pin LGA Platform-in-Package (PiP) solution that can be used for wireless applications ranging from simple proprietary point-to-point connectivity to complete ZigBee mesh networking. The MC1322x is designed to provide a highly integrated, total solution, with premier processing capabilities and very low power consumption.

The MC1322x MCU resources offer superior processing power for ZigBee and IEEE 802.15.4 applications. A full 32-bit ARM7TDMI-S core operates up to 26 MHz. A 128 Kbyte FLASH memory is mirrored into a 96 Kbyte RAM for upper stack and applications software. In addition, an 80 Kbyte ROM is available for boot software, peripheral device drivers, standardized IEEE 802.15.4 MAC and communications stack software. A full set of peripherals and Direct Memory Access (DMA) capability for transceiver packet data complement the processor core.

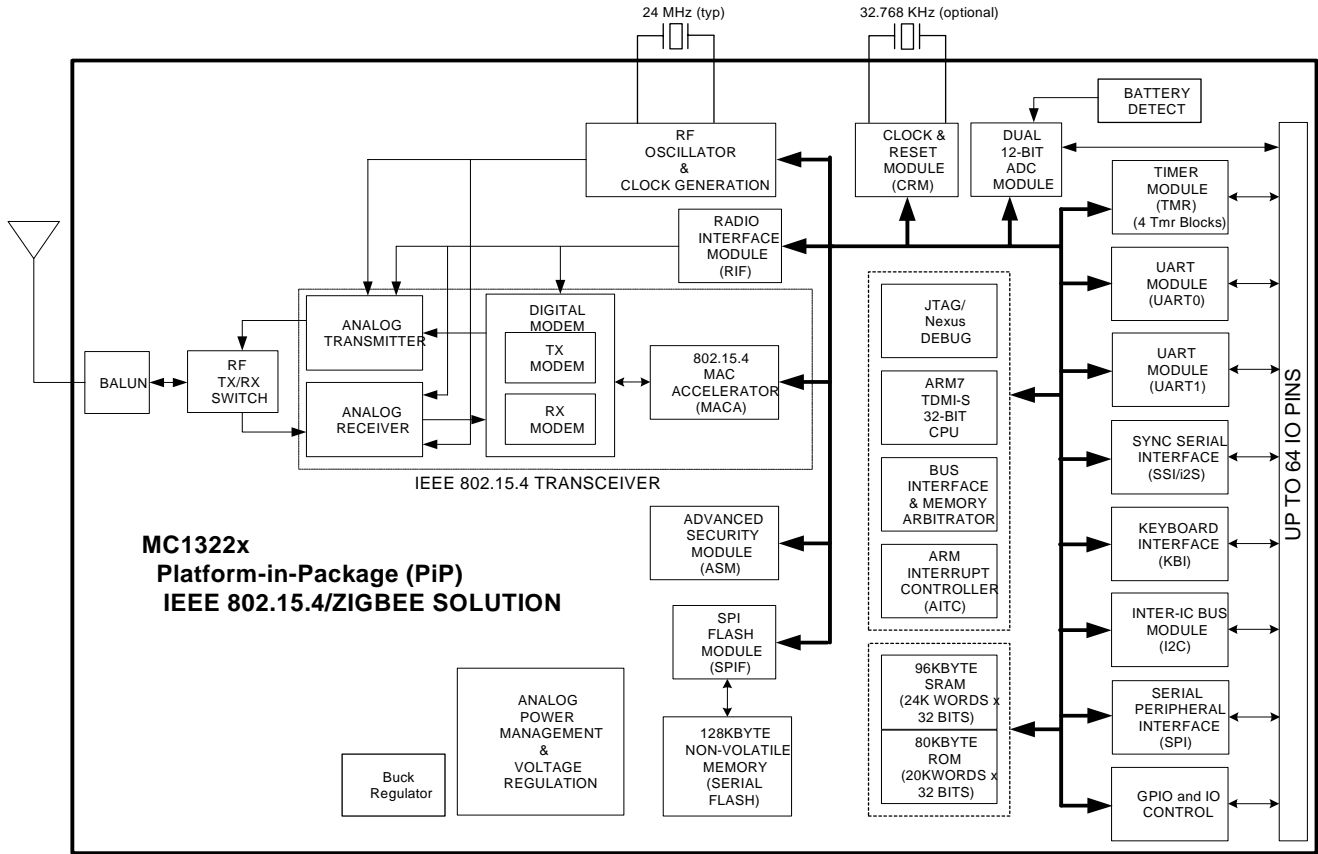

Figure 3-2. MC1322x Block Diagram

The RF radio interface provides for low cost and high density as shown in Figure 3-3. An onboard balun along with a TX/RX switch allows direct connection to a single-ended 50-Ω antenna. The integrated PA provides programmable output power typically from -30 dBm to +4 dBm, and the RX LNA provides -95 dBm sensitivity. This solution also has onboard bypass capacitors and crystal load capacitors for the smallest footprint in the industry. All components are integrated into the package except the crystal and antenna.

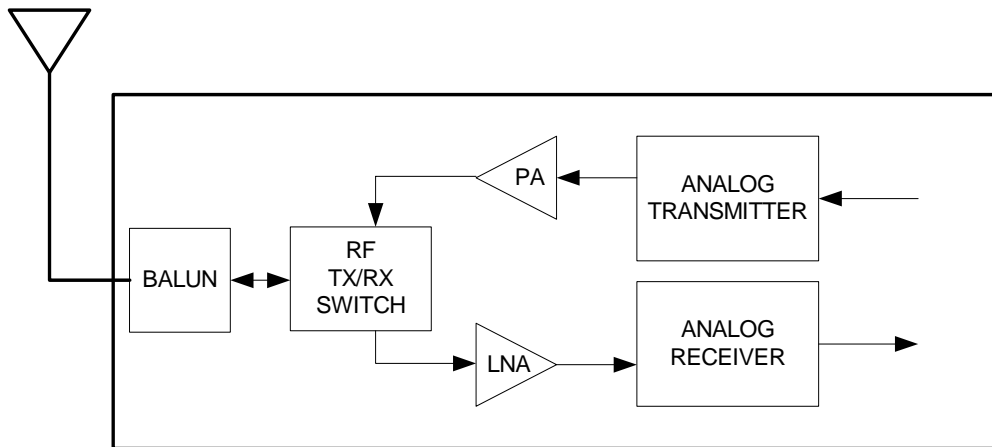
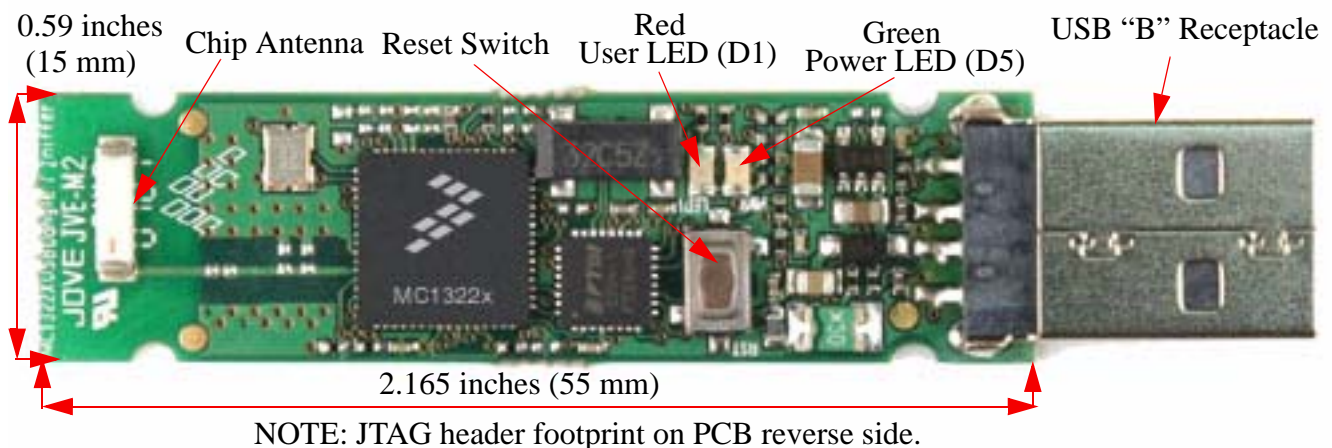

Figure 3-3. MC1322x RF Interface

Augmenting the core device on the 1322x USB Dongle are:

- Low-cost 2.4 GHz ISM Band radio
- 2.0 USB connection
- User interface LED
- Optional debug / development port
- Reset switch

Users are encouraged to reference the board schematic for the topics covered in the following sections. [Figure 3-4](#) and [Figure 3-5](#) shows the 1322x USB Dongle PCB top and bottom view with interface designations.



**Figure 3-4. 1322x USB Dongle PCB Top View**

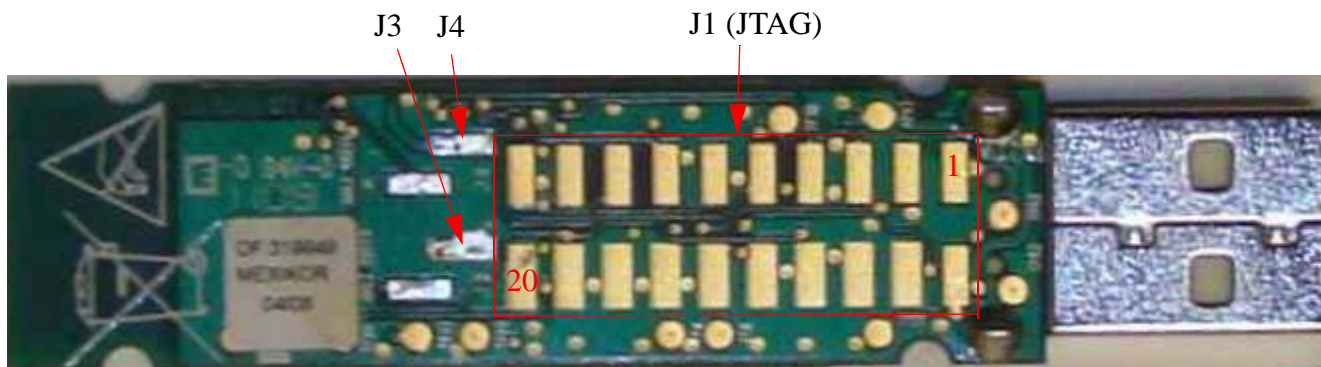

**Figure 3-5. 1322x USB Dongle PCB Bottom View**

### 3.3 Power Source

The device is powered directly from the USB connection

- The main source is the USB “B” Receptacle
- The USB connection powers the FTDI FT232R USB<>UART interface device. In turn, the FT232R has an onboard 3.3 V output series regulator that powers the rest of the module.

- A green power-on LED (D5) is provided

### 3.4 Low-cost 2.4 GHz ISM Band radio

The MC1322x provides an onboard balun, antenna switch, and LNA. The only external component required for the radio is an antenna. The USB dongle uses a PCB-mounted chip antenna. Figure 3-6 shows the RF network external to the MC1322x.

- Typical nominal output power is 0 dBm, with +4 dBm max
- Typical sensitivity is -95 dBm.
- Frequency range is 2405 to 2480 MHz
- Typical range (outdoors, line of sight) is 300 meters

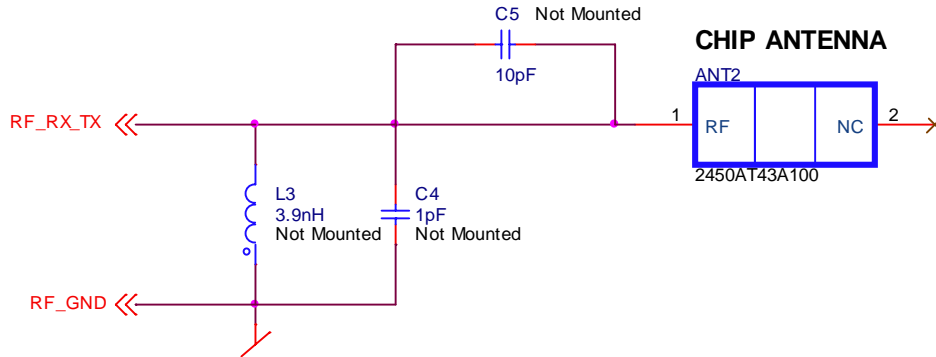

Figure 3-6. 1322x USB Dongle RF Network

### 3.5 USB Interface

Primary connection to the wireless node is the USB port that is provided via a USB “B” receptacle designated as J2. Figure 3-7 shows the connector pinout.

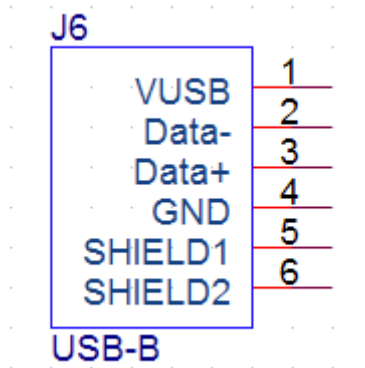

Figure 3-7. USB Connector Pinout

The port is connected to a FTDI FT232R USB <math>\leftrightarrow</math> UART device that appears as a Virtual COM port (VCP) to the PC. PC drivers are available with the module. The USB interface is configured as a “Bus Powered” device and draws all required power from the USB interface. The device is USB 2.0, full speed compatible.



## 3.6 Clock

The MC1322x device has a primary reference oscillator of 24 MHz. Crystal X1 is used with the MC1322x for the reference oscillator.

## 3.7 Reset Switch and LEDs

The USB dongle provides the following

- One green Power-On LED (D5)
- One red LED (D1) is driven by the MCU and controlled by the software application.
- Reset switch to the wireless node; does not reset the USB interface device.

**Table 3-1. Switch and LED Summary**

Item	Connection	Feature
PWR (green)	VCC	'Power On' indication
LED1 (red)	KBI_1	Application specific
SW5	$\overline{\text{RESETB}}$	Reset to MC1322x

Refer to [Figure 3-4](#) for location of switches and LEDs.

## 3.8 FLASH Memory Recovery Jumpers and Erase

The MC1322x has an onboard serial FLASH that stores the memory image that gets loaded into RAM at boot. If it becomes necessary to change or update the image in FLASH, there are two possible means of doing so:

- JTAG Debug Port - if the JTAG connector is mounted and the ARM debug tools are in use, the FLASH image can be changed.
- Load new FLASH image via USB port:
  - The Freescale BeeKit IDE download provides a software tool called Test Tool. This application runs on a PC and can be used with a client running on the MC1322x to test the platform.
  - Test Tool also has the capability to load a new image into the FLASH through the USB port. However, the FLASH must first be cleared.

The 1322x USB Dongle has two jumper sites designated as J3 and J4 (see [Figure 3-8](#)) located on the non-component (back) side of the PCB (see [Figure 3-5](#)). Use these jumper sites to erase the FLASH.

1. Short Jumper J3 Pin 1 to Pin 2.
2. Short Jumper J4 Pin 1 to Pin 2.

### NOTE

For development purposes SMD headers can be soldered to the header sites to make this action easily done with shorting bars.

3. Power on the USB board by plugging it into a USB port.

4. Push the reset button on the USB board.
5. Disconnect the USB board from USB port.
6. Remove the jumpers from both J3 and J4.
7. The board is now ready for boot operation. After the FLASH is erased, plug the module into the USB connection again. The board is now ready to be loaded with a new image using the Freescale Test Tool application.

### NOTE

Refer to the Freescale *Test Tool User's Guide* as supplied with Test Tool in the BeeKit Wireless Connectivity Toolkit download.

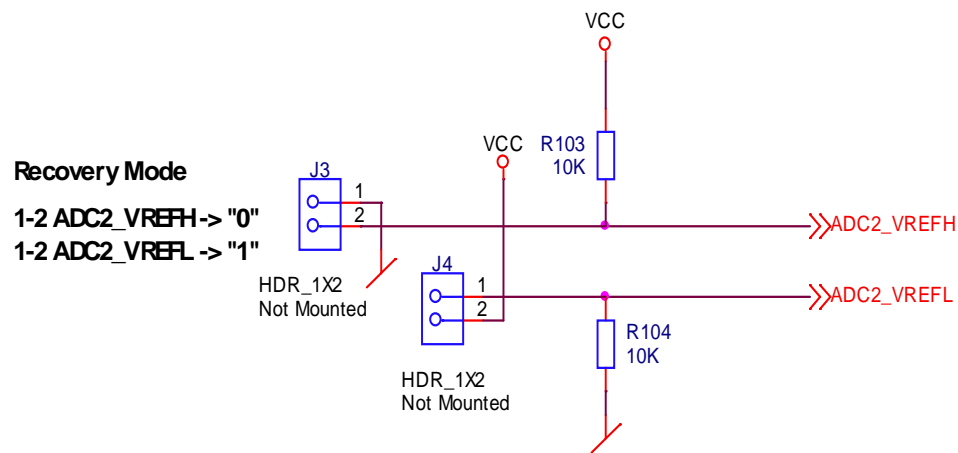

Figure 3-8. FLASH Erase Headers

## 3.9 Optional Debug/Development Interface (ARM JTAG Interface)

The module optionally supports the standard JTAG debug port. A 20-pin footprint is provided for a standard JTAG debug interface connector. This debug port only requires a simple interface cable to connect to a PC and use standard ARM software development tools.

The MC1322x supports connection to a subset of the defined ARM JTAG connector. The JTAG interface is a standard 2.54mm/0.1inch spacing, 20-pin debug interface (J1). The footprint for the 20-pin connector is located at the rear side of the module. A Pin 1 marking is given for correct plug-in of the development cable.

Table 3-2 shows the device pins that are connected to the associated JTAG header pin outs if the JTAG connector is used.

### NOTE

The required header is a 20-position, 0.100" straight SMD connector. Molex/Walldom #15-91-0200 or equivalent.

**Table 3-2. ARM JTAG 20-Pin Connector Assignments (J1)**

Name <sup>1</sup>	Pin #	Pin #	Name
VCC	1	2	VCC
NC <sup>2</sup>	3	4	GND
TDI	5	6	GND
TMS	7	8	GND
TCK	9	10	GND
RTCK	11	12	GND
TDO	13	14	GND
RESET <sup>3</sup>	15	16	GND
NC	17	18	GND
NC	19	20	GND

<sup>1</sup> NC means No Connect.

<sup>2</sup> MC1322x does not support separate JTAG reset TRST.

<sup>3</sup> VCC through a 100k-ohm pullup.



# Chapter 4 Schematic, Board Layout, and Bill of Materials

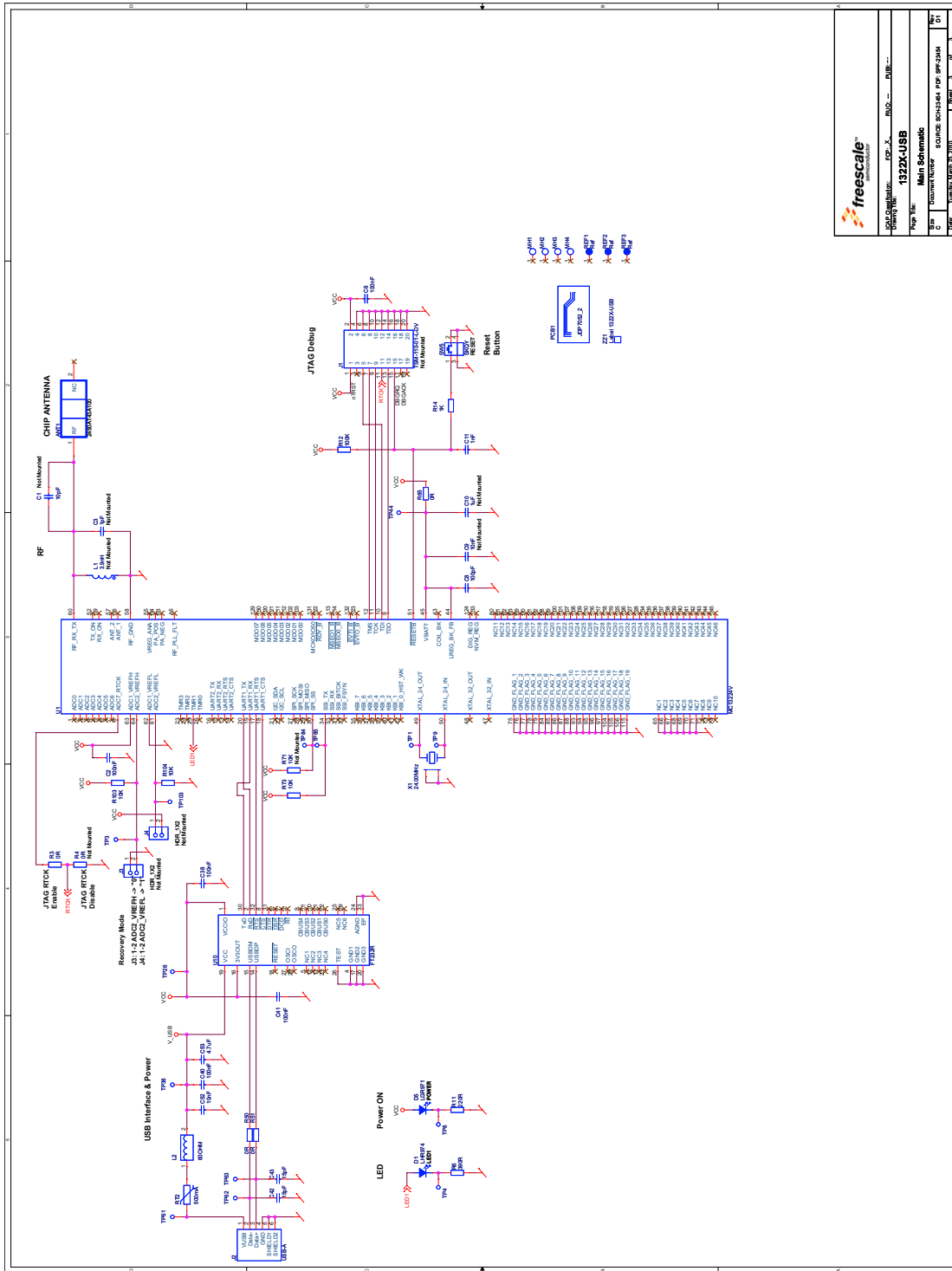

Figure 4-1. 1322x USB Dongle Schematic

Part Number: 1322X-USB	Rev: 1.0
Title: Main Schematic	Date: 01/11/2011
Author:	Designer:
Checked:	Approved:
Component Number:	Project Number:
Date:	Sheet:
Total:	of:

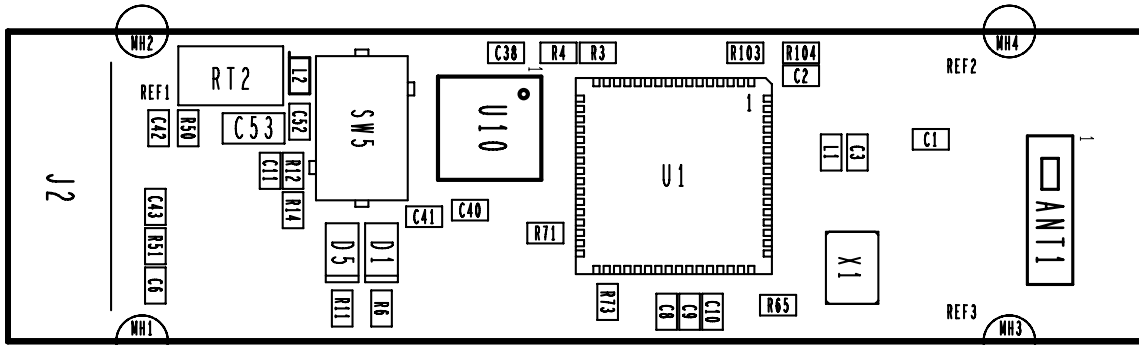

Figure 4-2. 1322x USB Dongle PCB Component Location (Top View)

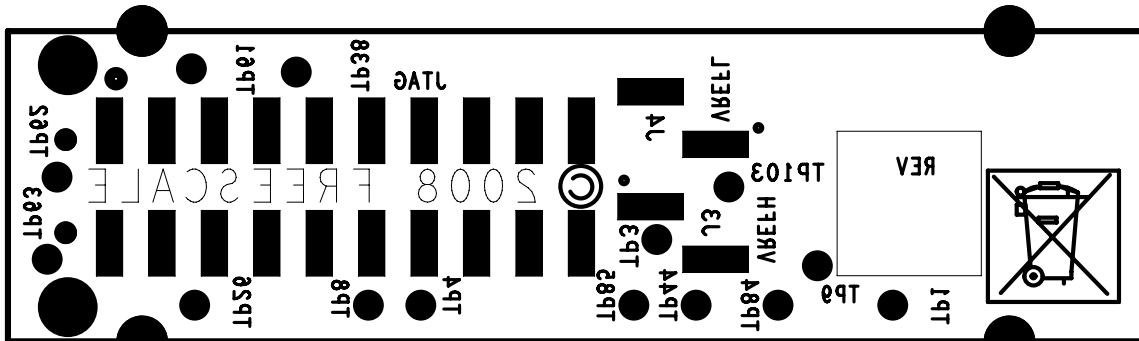

Figure 4-3. 1322x USB Dongle PCB Test Points (Bottom View)

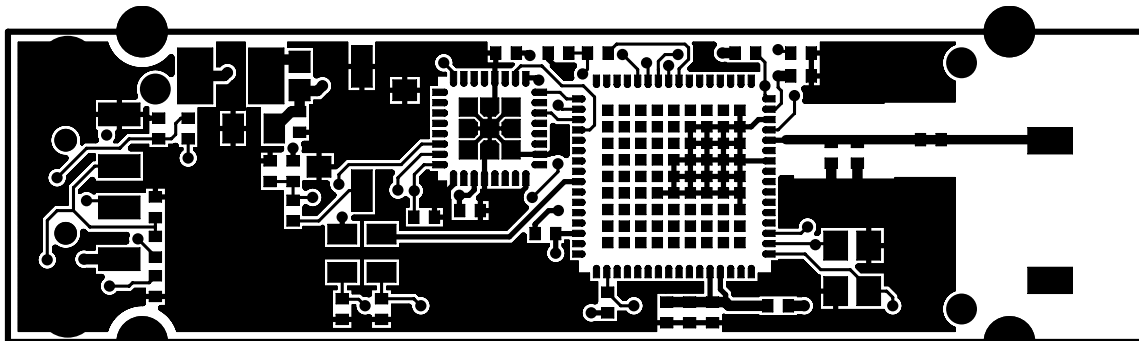

Figure 4-4. 1322x USB Dongle PCB Layout (Top View)

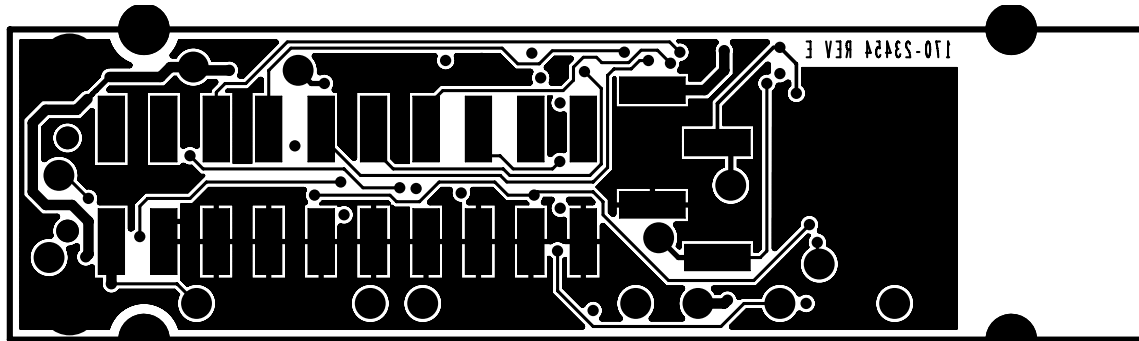

Figure 4-5. 1322x USB Dongle PCB Layout (Bottom View)

Table 4-1. Bill of Materials

Qty	Part Reference	Description	Value	Voltage	Manufacturer	Manufacturer Part Number
1	ANT1	ANTENNA 2.45GHZ SMT 50 OHM CASE43-1	ANTENNA_2 .45GHZ		JOHANSON TECHNOLOGY	2450AT43A100
0	C1	Ceramic Capacitor C0G	10pF Not Mounted	50V	Murata	GRM1555C1H100JZ01
5	C2,C6,C38, C40,C41	Ceramic Capacitor X5R	100nF	10V	Murata	GRM155R61A104KA01D
0	C3	Ceramic Capacitor C0G	1pF Not Mounted	50V	Murata	GRM1555C1H1R0CZ01D
	C8	Ceramic Capacitor C0G	100pF	50V	Murata	GRM1555C1H101JZ01
0	C9	Ceramic Capacitor X7R	10nF Not Mounted	25V	Murata	GRM155R71E103KA01D
0	C10	Ceramic Capacitor X5R	1uF Not Mounted	6.3V	Murata	GRM155R60J105KE19B
1	C11	Ceramic Capacitor X7R	1nF	50V	Murata	GRM155R71H102KA01D
2	C42,C43	Ceramic Capacitor C0G	15pF	50V	Murata	GRM1555C1H150JZ01J
1	C52	Ceramic Capacitor X7R	10nF	25V	Murata	GRM155R71E103KA01D
1	C53	Ceramic Multilayer Capacitor X5R	4.7uF	10V	Murata	GRM219R61A475KE34D
1	D1	SMD Red topped	LHR974		OSRAM	Q62702P5182
1	D5	SMD Green topped	LGR971		OSRAM	Q65110P5179
0	J1	Dual Row Straight Pin Header SMD	TSM-110-01- L-DV Not Mounted	Samtec	TSM-110-01-L-DV- M	
1	J2	USB-series "A" plug	USB-A		Samtec	USB-AM-S-S-B-SM1-R-TR
0	J3,J4	HDR 1X2 SMT 100MIL SP 380H AU	HDR_1X2 Not Mounted		SAMTEC	TSM-102-01-SM-SV-P-TR
0	L1	HF Chip coil	3.9nH Not Mounted		Murata	LQG15HS3N9S02D
1	L2	IND FER BEAD 60OHM@100MHZ 500MA -- 0603	60OHM		MURATA	BLM18PG600SN1_
1	RT2	Polyswitch Overcurrent Protection Device	500mA	13.2V	Tyco Electronics	microSMD050F
4	R3,R50,R51, R65	Fixed resistor RC31	0R	50V	Phillips	2322 705 91002
0	R4	Fixed resistor RC31	0R Not Mounted	50V	Phillips	2322 705 91002
1	R6	Fixed resistor RC31	390R	50V	Phillips	2322 705 50391

Table 4-1. Bill of Materials

Qty	Part Reference	Description	Value	Voltage	Manufacturer	Manufacturer Part Number
1	R11	Fixed resistor RC31	220R	50V	Phillips	2322 705 50221
1	R12	Fixed resistor RC31	100K	50V	Phillips	2322 705 50104
1	R14	Fixed resistor RC31	1K	50V	Phillips	2322 705 50102
0	R71	Fixed resistor RC31	10K Not Mounted	50V	Phillips	2322 705 50103
3	R73,R103,R104	Fixed resistor RC31	10K	50V	Phillips	2322 705 50103
1	SW5	SMD Tact Switch 3.14N (2.5mm)	SKQY		ALPS	SKQYPDE010
1	U1	ZigBee Wireless Transceiver and ARM7 processor	MC13224V		Freescale	MC13224V
1	U10	USB UART, PB-free	FT232R		FTDI	FT232RQ
1	X1	Crystal SMD	24.00MHz	+/-10ppm	NDK	EXS00A-CS02020 (24MHz NX3225SA) (for OA/AV and Bluetooth)



## Chapter 5

# PCB Manufacturing Specifications

This chapter provides the specifications used to manufacture the 1322x USB Dongle printed circuit board (PCB).

The 1322x USB Dongle PCB must comply with the following:

- The PCB must comply with Perfag10/3C (<http://www.perfag.dk/Uk/ukindex.htm>)
- The PCB manufacturer's logo is required
- The PCB production week and year code is required
  - The manufacturer's logo and week/year code must be stamped on the back of the PCB solder mask
  - The PCB manufacturer can not insert text on the PCB either in copper or in silkscreen without written permission from Freescale Semiconductor, Inc.
- The required Underwriter's Laboratory (UL) Flammability Rating
  - The level is 94V-0 (<http://www.ul.com/plastics/flame.html>)
  - The UL information must be stamped on the back of the PCB solder mask

### NOTE

- A complete set of design files is available the 1322x USB Dongle at the Freescale web site (<http://www.freescale.com/802154>) under reference designs. It is recommended that this design or one of a number of other reference designs be used as a starting point for a custom application.
- The *Freescale IEEE 802.15.4 / ZigBee Package and Hardware Layout Considerations Reference Manual*, Document Number: ZHDCRM is also available at the same web site to provide additional design guidance.

## 5.1 Single PCB Construction

This section describes individual PCB construction details.

- The PCB is a four layer, multi-layer design
- The PCB contains no blind, buried, or micro vias
- PCB data:
  - Size: Approximately 55 x 15 mm (2.165 x 0.590 inches)
  - Final thickness (Cu/Cu): 0.864 mm (0.034 inches) +/- 10% (excluding solder mask)
- The following table defines each layer of the completed PCB. The artwork identification refers to the name of the layer in commonly used terms.

**Table 5-1. Layer by Layer Overview**

Layer	Artwork Identification	File Name
1	Solder Resist	MASK1.art
2	Copper Top Layer (component side; layer 1)	LAY1.art
3	Copper 2nd Layer	LAY2.art
4	Copper 3rd Layer	LAY3.art
5	Copper bottom Layer	LAY4.art
6	Solder Resist	MASK2.art

**NOTE**

The 1322x USB Dongle contains high frequency 2.4 GHz RF circuitry. As a result, RF component placement, line geometries and layout, and spacing to the ground plane are critical parameters. As a result, BOARD STACKUP GEOMETRY IS CRITICAL. Dielectric and copper thicknesses and spacing must not be changed; follow the stackup (see [Figure 5-1](#)) information is provided with the reference design.

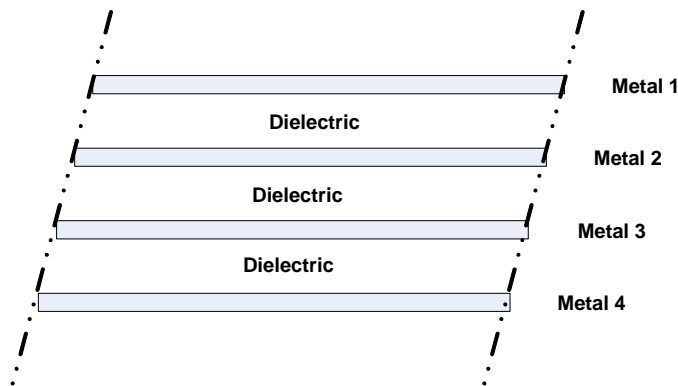

**Figure 5-1. PCB Stackup Cross-Section**

- Solder mask is required
- Silk screen is required

## 5.2 Panelization

The panel size can be negotiated depending on production volume.

## 5.3 Materials

The PCB composite materials must meet the following requirements:

- Laminate - The base laminate material (laminate) must be FR4. If the laminate material were changed the RF electrical characteristics may change and degrade RF performance.
- Copper Foil -
  - Top and Bottom copper layers must be 1 oz. copper
  - Interior layers must be 1/2 oz. copper
- Plating - All pad plating must be Hot Air Levelling (HAL)

## 5.4 Solder Mask

The solder mask must meet the following requirements:

- Solder mask type: Liquid Film Electra EMP110 or equivalent
- Solder mask thickness: 10 – 30  $\mu\text{m}$

## 5.5 Silk Screen

The silk screen must meet the following requirements:

- Silkscreen color: White
- Silkscreen must be applied after application of solder mask if solder mask is required
- The silkscreen ink must not extend into any plated-thru-holes
- The silk screen must be clipped back to the line of resistance

## 5.6 Electrical PCB Testing

- All PCBs must be 100 percent tested for opens and shorts
- Impedance Measurement - An impedance measurement report is not mandatory

## 5.7 Packaging

Packaging for the PCBs must be the following requirements:

- Finished PCBs must remain in panel
- Finished PCBs must be packed in plastic bags that do not contain silicones or sulphur materials. These materials can degrade solderability.

## 5.8 Hole Specification/Tool Table

See the `ncdrill-1-4.tap` file included with the Gerber files.

## 5.9 File Description

Files included with the download include Design, Gerber and PDF files.

Gerber files are RS-374x format. Not all files included with the Gerber files are for PCB manufacturing.

PDF files included are assembly drawings (ASSY1 and ASSY2), board fabrication drawing (FAB-23454), the four metal layers (LAYx), solder mask (MASKx), solder paste (PASTE1) and silk screen (SILKx). The schematic is SPF-23454\_REV\_x.

Design files are in Allegro format with OrCAD schematic capture.