

För icke direkt toleranssatta mått gäller toleransklass
General tolerances if not otherwise stated

NOM DIM MM		TOL CLASS		
From	To	A	B	C
(1)	6	±0.05	±0.1	±0.2
(6)	30	±0.1	±0.2	±0.5
(30)	100	±0.15	±0.3	±0.8
(100)	300	±0.2	±0.5	±1.2
(300)	1000	±0.3	±0.8	±2

Hål / Holes H13

Skarpa kanter brutna där ej annat anges.
No sharp edges unless otherwise specified.

Övriga generella toleranser enligt ritning 4100-4644.
Additional general tolerances in accordance with drawing 4100-4644.

LASERMÄRKNING/LASER MARKING:

TEXTFONT: GEN-ISO

Datumkod / Date code "YYYYYY"

Serienummer / Serial number "XXXXXXX"

Rev	Change order	Change: A = Added W = Was D = Deleted C = Changed	Date	Sign
1	1046196000	D 4100-1298A	100322	SE
2	1046348000	D609.541 W Pat. pend.	100331	SE

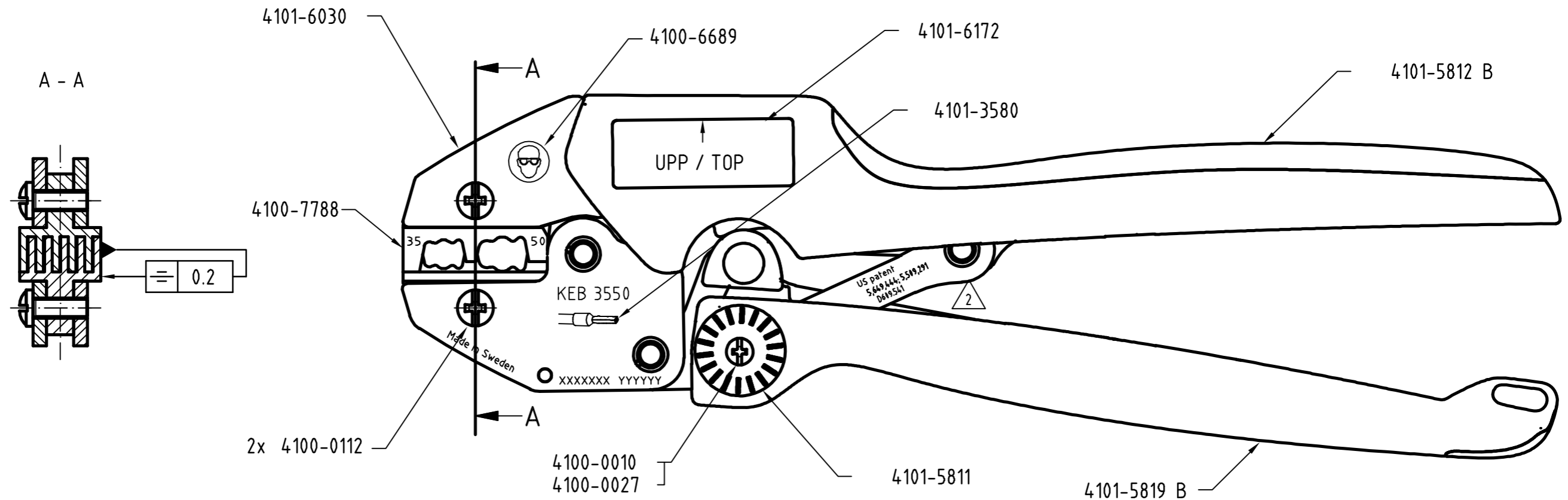

4101-2610
4101-5828
4101-6507 C - placering position A
4101-6301
TILLTRYCK PÅ KORT (4101-6301) ENLIGT OMT DOKUMENT NR.:1044654000
PRINTING ON CARD (4101-6301) ACCORDING TO OMT DOCUMENT NO.:1044654000

FÖRSPÄNNING / PRELOAD: 100 ± 30 N

Tolkmått / Gauge dimensions (mm)		
URTAG	Gåtolk	Stopptolk
NEST	GO	NO GO
35	∅5.17	∅5.37
50	∅6.43	∅6.63

Packas enligt förpackningsritning 4101-2741
Packed according to drawing 4101-2741

Material		Behandling/Treatment			Status	
Konstr./Design SE	Ritad/Drawn SE	Datum/Date 2010-03-31	Skala/Scale 1:1	Kontr./Checked IP	Godk./Approved NE	Änne/Blank Frisläppt
pressmaster ®				Benämning/Denomination Krimptång KEB 3550		Vikt/Veigt,gram 012
ISO 9001 REG NR FM13647				Krimptång KEB 3550 CRIMPING TOOL		Art grp 012
				Ritn nr./Drawing no 43003764		REV 002

Den här ritning är Pressmaster AB:s egendom. Skyddad av gällande lag.
This drawing is the property of Pressmaster AB. Protected in accordance with prevailing law.