

Hardware User Manual

CM-BF537E V1.1 (V1.2)

www.tinyboards.com

Maximum Power at Minimum Size

Contact

Bluetechnix Mechatronische Systeme GmbH

Waidhausenstr. 3/19
A-1140 Vienna
AUSTRIA/EUROPE
office@bluetechnix.at
<http://www.bluetechnix.com>

Document No.: 100-1221-1.1

Version 7

Date: 2007-05-03

Table of Contents

1	Introduction	1
1.1	Overview	1
1.2	Benefits	2
1.3	Applications	2
2	Specification	3
2.1	Functional Specification	3
2.2	Boot Mode	3
2.3	Memory MAP	4
2.4	Electrical Specification	4
2.4.1	Supply Voltage	4
2.4.2	Supply Voltage Ripple	4
2.4.3	External Oscillator Frequency	4
2.4.4	Real Time Clock Crystal	4
2.4.5	Supply Current	4
2.5	Environmental Specification	4
2.5.1	Temperature	4
2.5.2	Humidity	5
3	CM-BF537E (Connector Version)	6
3.1	Mechanical Outline	6
3.2	Footprint - Connector Version	7
3.3	Top Mounted Components	8
3.4	Schematic Symbol (Signals of P1 and P2)	9
3.5	Connectors Pin Assignment	10
3.5.1	Connector P1 – (1-60)	10
3.5.2	Connector P2 – (61-120)	11
3.5.3	Pin out Description	12
3.6	RJ45 schematic	12
4	Test Points	14
4.1	Footprint – Test Points	14
5	Software Support	15
5.1	BLACKSheep	15
5.2	uClinux	15
6	Application Examples	16

6.1	Sample Schematic	16
6.2	Stand-alone Ethernet based MPEG Webcam.....	17
6.3	Design Services.....	18
7	Known Bugs	19
8	Product Changes	20
9	Document Revision History	21
A	List of Figures and Tables	22

Edition 2007-02

© Bluetechnix Mechatronische Systeme GmbH 2007

All Rights Reserved.

The information herein is given to describe certain components and shall not be considered as a guarantee of characteristics.

Terms of delivery and rights of technical change reserved.

We hereby disclaim any warranties, including but not limited to warranties of non-infringement, regarding circuits, descriptions and charts stated herein.

Bluetechnix makes and you receive no warranties or conditions, express, implied, statutory or in any communication with you. Bluetechnix specifically disclaims any implied warranty of merchantability or fitness for a particular purpose.

Bluetechnix takes no liability for any damages and errors causing of the usage of this board. The user of this board is responsible by himself for the functionality of his application. He is allowed to use the board only if he has the qualification. More information is found in the General Terms and Conditions (AGB).

Information

For further information on technology, delivery terms and conditions and prices please contact Bluetechnix (<http://www.bluetechnix.com>).

Warnings

Due to technical requirements components may contain dangerous substances.

The Core Boards and Development systems contain ESD (electrostatic discharge) sensitive devices. Electrostatic charges readily accumulate on the human body and equipment and can discharge without detection. Permanent damage may occur on devices subjected to high-energy discharges. Proper ESD precautions are recommended to avoid performance degradation or loss of functionality. Unused core boards and development boards should be stored in the protective shipping package.



BLACKFIN Products

Core Modules:

- CM-BF533: Blackfin Processor Module powered by Analog Devices single core ADSP-BF533 processor; up to 600MHz, 32MB RAM, 2MB Flash, 120 pin expansion connector and a size of 36.5x31.5mm
- CM-BF537E: Blackfin Processor Module powered by Analog Devices single core ADSP-BF537 processor; up to 600MHz, 32MB RAM, 4MB Flash, integrated TP10/100 Ethernet physical transceiver, 120 pin expansion connector and a size of 36.5x31.5mm
- CM-BF537U: Blackfin Processor Module powered by Analog Devices single core ADSP-BF537 processor; up to 600MHz, 32MB RAM, 4MB Flash, integrated USB 2.0 Device, 120 pin expansion connector and a size of 36.5x31.5mm
- TCM-BF537: Blackfin Processor Module powered by Analog Devices single core ADSP-BF537 processor; up to 500MHz, 32MB RAM, 8MB Flash, 28x28mm, 120 pin expansion connector, Ball Grid Array or Border Pads for reflow soldering, industrial temperature range -40°C to +85°C.
- CM-BF561: Blackfin Processor Module powered by Analog Devices dual core ADSP-BF561 processor; up to 2x 600MHz, 64MB RAM, 8MB Flash, 120 pin expansion connector and a size of 36.5x31.5mm
- CM-BF527: From Q3 '07 a new Blackfin Processor Module powered by Analog Devices single core ADSP-BF527 processor will be available; key features are USB OTG 2.0 and Ethernet. 2x120pin expansion connectors are backwards compatible to other Core Modules.
- CM-BF548: From Q3 '07 a new Blackfin Processor Module powered by Analog Devices single core ADSP-BF548 processor will be available; key features are 64MB DDR SD-RAM 2x100pin expansion connectors.

Development Boards:

- EVAL-BF5xx: Low cost Blackfin processor Evaluation Board with one socket for any Bluetechnix Blackfin Core Module. Additional periphery is available, such as a SD-Card.
- DEV-BF5xxDA-Lite: Get ready to program and debug Bluetechnix Core Modules with this tiny development platform including a USB Based Debug Agent. The DEV-BF5xxDA-Lite is a low cost starter development system including VDSP++ Evaluation Software License.

- DEV-BF5xx-FPGA: Backfin Development Board with two sockets for any combination of Blackfin Core Modules. Additional periphery is available, such as SD-Card, Ethernet, USB host, multi-port JTAG including a USB based Debug Agent, connector for a LCD-TFT Display and connector for a digital camera system. A large on-board SPARTAN-3 FPGA and Soft IPs make this board the most flexible Blackfin development platforms ever developed.
Available Q2 2007
- EXT-Boards: The following Extender Boards are available: EXT-BF5xx-Audio, EXT-BF5xx-Video, EXT-BF5xx-Camera, EXT-BF5xx-Exp, *EXT-BF5xx-LVDS, *EXT-BF5xx-ETH-USB, *EXT-BF5xx-AD/DA.
Additional boards based on customer request
*Available Q2 2007

Software Support:

- BLACKSheep: The BLACKSheep VDK is a multithreaded framework for the Analog Devices Blackfin processor family that includes driver support for a variety of hardware extensions. It is based on the real-time VDK kernel included within the VDSP++ development environment.
- LabVIEW: LabVIEW embedded support for the CM-BF537E, CM-BF537U and TCM-BF537 Core Modules based on the BLACKSheep VDK driver Framework.
- uClinux: All the Core Modules are supported by uClinux. The required boot loader and uClinux can be downloaded at <http://blackfin.uClinux.org>.

BLACKFIN Design Service

Based on over three years Blackfin experience Bluetechnix offers development assistance as well as custom design services and software development.

1 Introduction

The CM-BF537E is a tiny, high performance and low power DSP/RISC Core Module incorporating Analog Devices Blackfin family of processors. The special feature of this module is the on-board 10/100Mbit Ethernet interface which includes the physical transceiver chip. The module allows easy integration into high demanding very space and power limited applications.

1.1 Overview

The Core Module CM-BF537E consists of the following components:

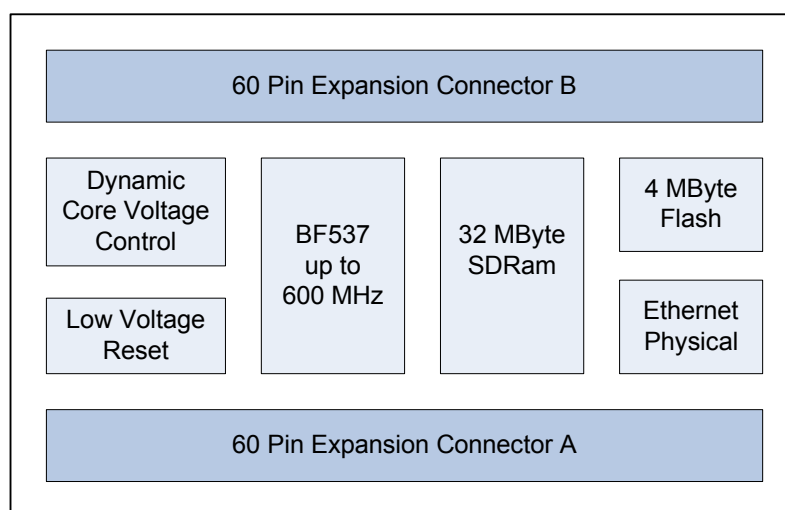

Figure 1-1: Main components of the CM-BF537E Core Module

- **Analog Devices Blackfin Processor BF537**
 - Supported Chips :
 - ADSP-BF537SBBC1500 (-40°-85°C) Option upon request
 - ADSP-BF537SKBC1600 (0°-70°C) Standard Mount
- **32 MB SDRAM**
 - SDRAM Clock up to 133MHz
 - MT48LC16M16A2BG-7 (16Mx16, 256Mbit at 3.3 V)
- **4 MB of Addressable Flash**
 - ITLRC28F320J3C110 (2Mx16 32Mbit at 3.3 V; all 4 MByte addressable)
 - Additional flash memory can be connected through the expansion board as parallel flash using asynchronous chip select lines or as a SPI flash.

- **Low Voltage Reset Circuit**
 - Resets module if power supply goes below 2.93 V for at least 140 ms
- **Dynamic Core Voltage Control**
 - Allows to adjust core voltage by setting software registers at the Blackfin processor
 - Core voltage range: 0.8 – 1.32V
- **Expansion Connector A**
 - Data Bus
 - Address Bus
 - Control Signals
 - Power Supply
 - Ethernet Pins
- **Expansion Connector B**
 - SPORT0
 - JTAG
 - UART0/UART1
 - CAN
 - TWI (I2C compatible)
 - SPI
 - PPI (Parallel Port Interface)
 - GPIO's

1.2 Benefits

- The CM-BF537E is very compact and measures only 36.5x31.5mm
- Allows quick prototyping of product that comes very close to the final design
- Reduces development costs, faster time to market
- Very cost effective for small and medium volumes

1.3 Applications

- Generic high performance signal processor module
- Internet Connected Embedded System
- High performance web camera
- Robotics: Tiny processor module for mobile robots

2 Specification

2.1 Functional Specification

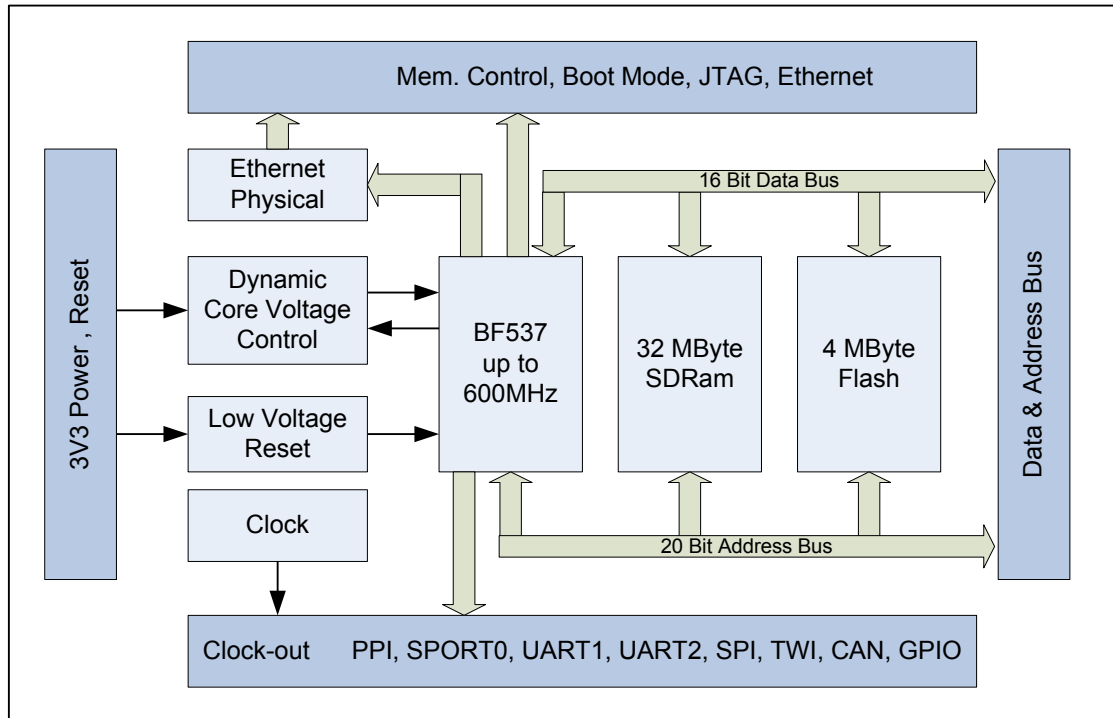

Figure 2-1: Detailed Block Diagram

Figure 2-1 shows a detailed block diagram of the CM-BF537E module. Beside the SDRAM control pins the CM-BF537E has all other pins of the Blackfin processor at its two main 60 pin connectors.

A special feature of the CM-BF537E Core Module is the on-board physical Ethernet transceiver from Micrel (KSZ8721BL).

Dynamic voltage control allows reducing power consumption to a minimum adjusting the core voltage and the clock frequency dynamically in accordance to the required processing power. A low voltage reset circuit guarantees a power on reset and resets the system when the input voltage drops below 2.93V.

2.2 Boot Mode

By default the boot mode = 000 (BMODE2 = low, BMODE1 = low, BMODE0 = low). All BMODE pins have internal pull down resistors.

Connect BMODE0 to Vcc and leave BMODE1, BMODE2 pins open for boot mode 001 equals to 8 or 16 bit PROM/FLASH boot mode, this is the default boot mode of the Blacksheep software. See Blackfin Datasheets or Eval/DevBoard manuals for more details.

2.3 Memory MAP

Memory Type	Start Address	End Address	Size	Comment
FLASH Bank0 (PF4 Flag low)	0x20000000	0x201FFFFFF	2MB	4MB Micron Flash, MT28F320J3FS-11
FLASH Bank1 (PF4 Flag high)	0x20000000	0x201FFFFFF	2MB	
SD-RAM	0x00000000	0x01FFFFFFF	32MB	16Bit Bus, Micron MT48LC16M16A2FG

Table 2-1: Memory Map

2.4 Electrical Specification

2.4.1 Supply Voltage

- 3.3V DC +/-10%

2.4.2 Supply Voltage Ripple

- 100mV peak to peak 0-20 MHz

2.4.3 External Oscillator Frequency

- 25 MHz

2.4.4 Real Time Clock Crystal

- 32.768kHz

2.4.5 Supply Current

- Maximum current: 350mA @ 3.3V
- Typical operating conditions:
 - Processor running at 600MHz, Core Voltage 1.2V, SDRAM 20% bandwidth utilization at 130MHz; Ethernet idle: 200mA @ 3.3V
 - Processor running at 300MHz, Core Voltage 0.8V SDRAM 20% bandwidth utilization at 130MHz; Ethernet idle: 140mA @ 3.3V
 - Processor running at 600MHz, Core Voltage 1.2V, SDRAM 20% bandwidth utilization at 130MHz, Ethernet TX/RX active: 250mA

2.5 Environmental Specification

2.5.1 Temperature

- Operating at full 600MHz: 0 to + 70° C

2.5.2 Humidity

Operating: 10% to 90% (non condensing)

3 CM-BF537E (Connector Version)

3.1 Mechanical Outline

TOP VIEW

All dimensions are given in millimeters!

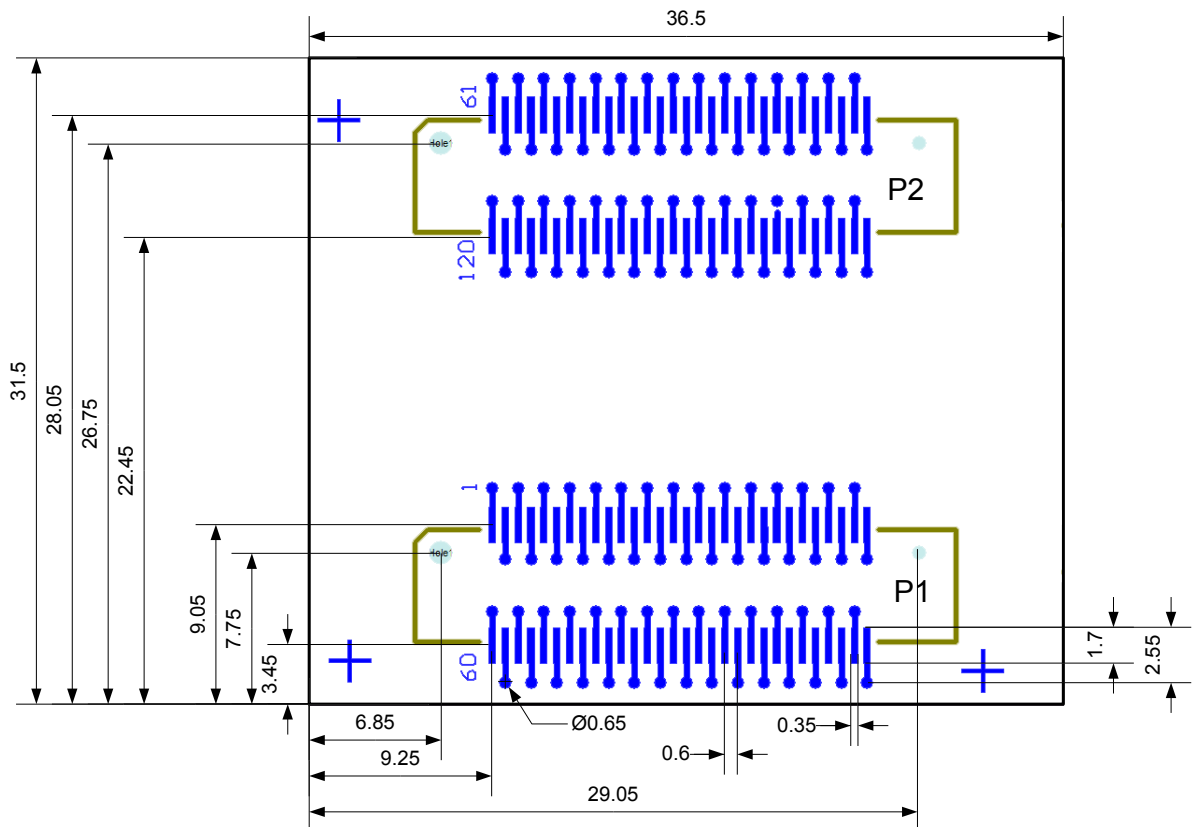

Figure 3-1: Mechanical outline and Bottom Connectors (top view)

The mechanical outline represents a top view of the connectors placed at the bottom of the core board.

The module is shipped with two 60pin connectors.

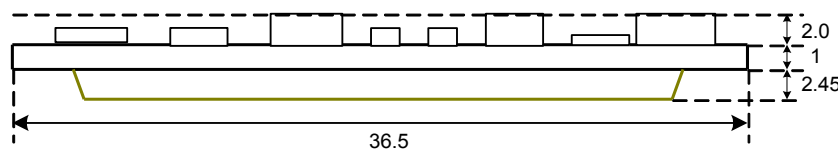

Figure 3-2: Side View with Connector mounted

The total minimum mounting height including receptacle at the motherboard is 6.1mm.

3.2 Footprint - Connector Version

If the connector version (2x Hirose 0.6mm pitch) is used, the footprint for the baseboard may look as shown in Figure 3-3.

For the baseboard the following connectors have to be used.

Part Baseboard	Manufacturer	Manufacturer Part No.
P1,P2	Hirose	FX8-60S-SV

Table 3-1: Baseboard connector types

The Connectors on the CM-BF537E are of the following type:

Part	Manufacturer	Manufacturer Part No.
P1,P2	Hirose 3mm height	FX8-60P-SV(21)

Table 3-2: Module connector types

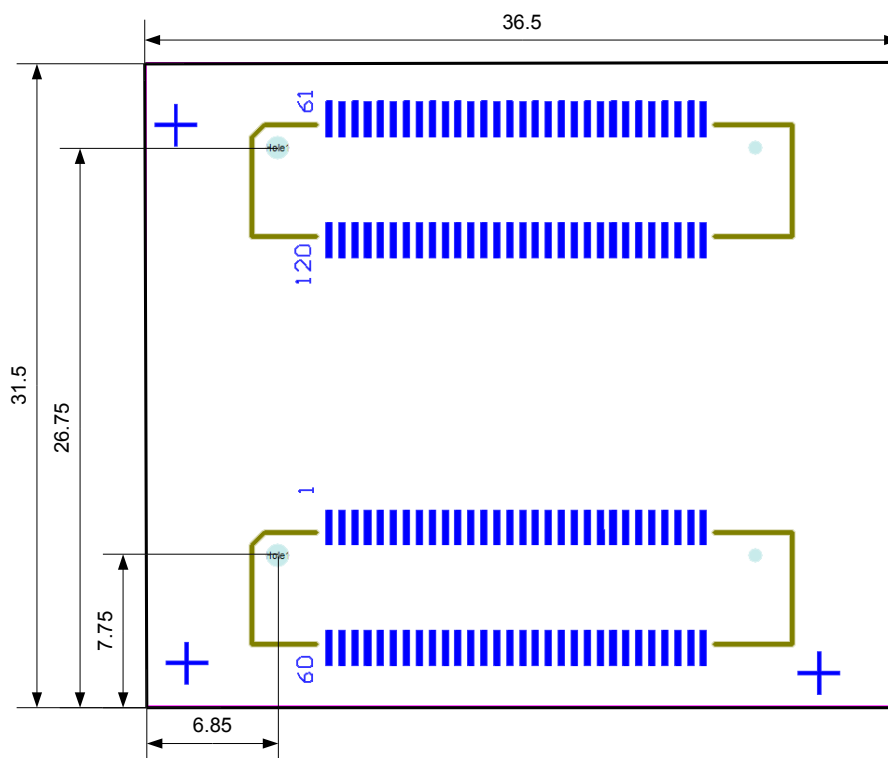

Figure 3-3: Connector footprint for the Core Module (top view)

3.3 Top Mounted Components

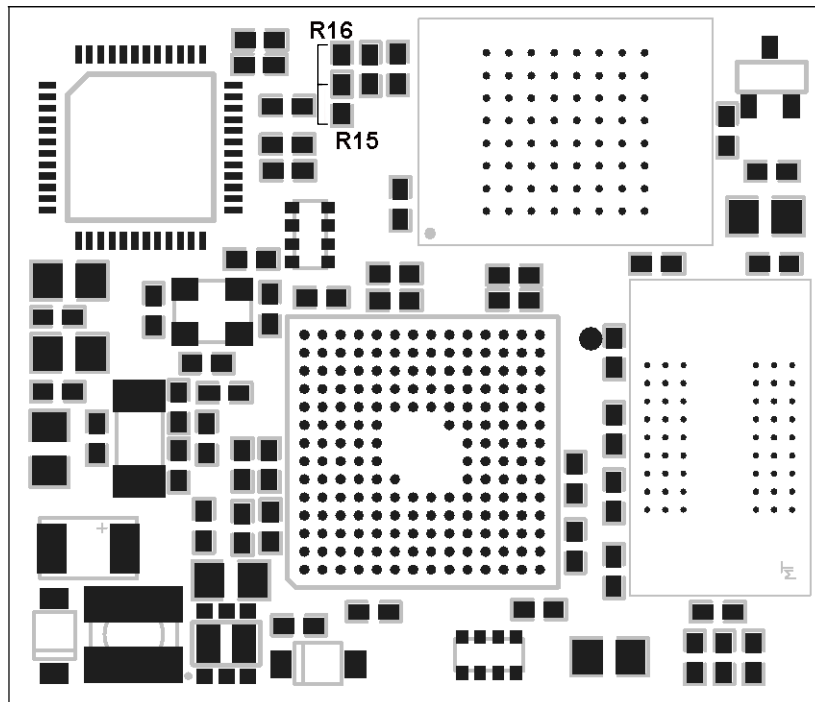

Figure 3-4: Core Module (component side)

NOTE: R16 is standard mount, hence PF4 is used as upper 2MB chip select for the flash, PF4 is not on the connector. If R15 is mounted instead, then PF4 is GPIO on PIN 7.

3.4 Schematic Symbol (Signals of P1 and P2)

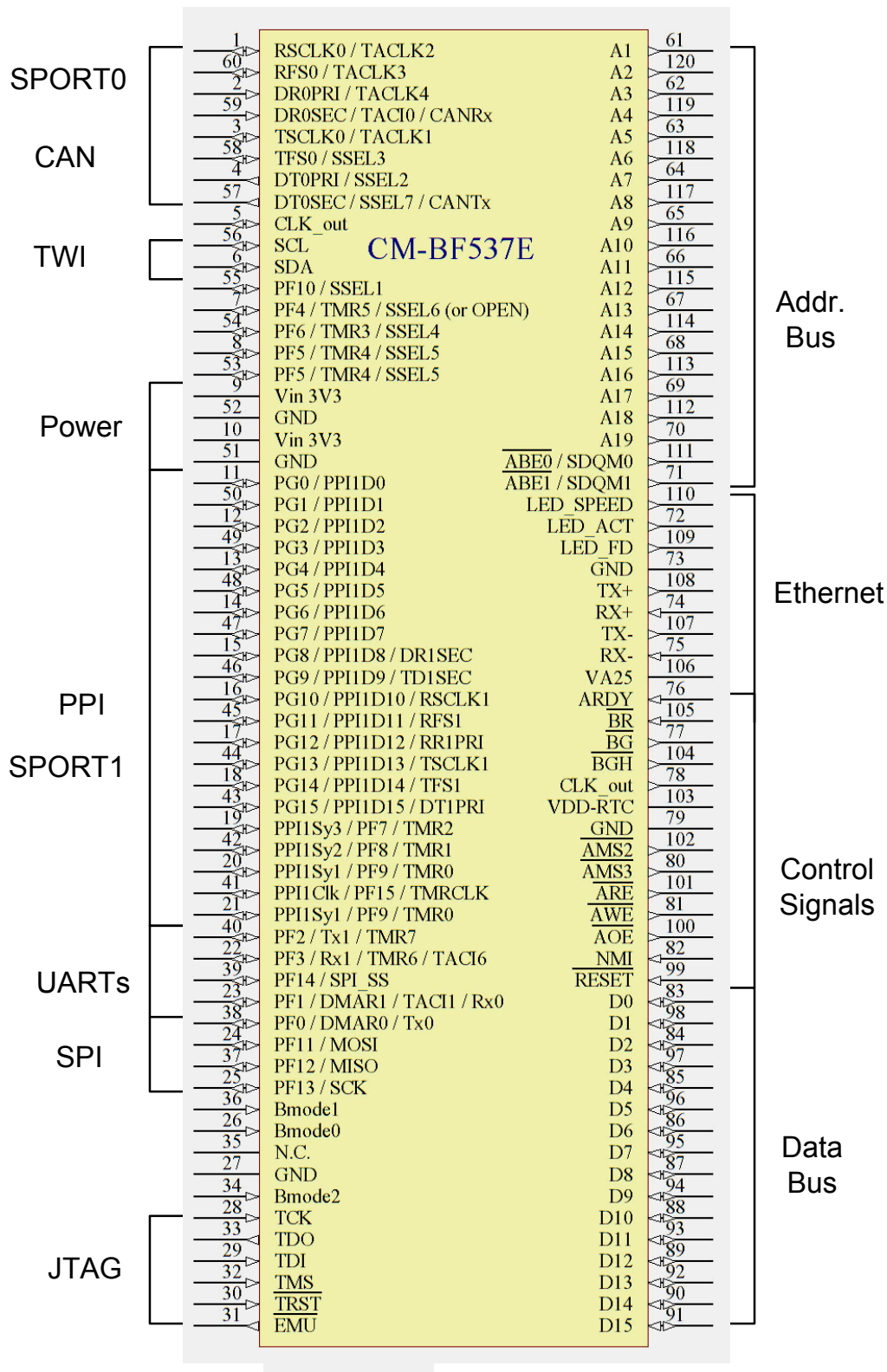

Figure 3-5: Schematic Symbol of Module

Note: For compatibility, 3 pins appear twice at the connector: CLK_out, PF5 and PPI1Sy1

3.5 Connectors Pin Assignment

3.5.1 Connector P1 – (1-60)

Pin No.	Signal	Signal type	Pin No.	Signal	Signal type
1	RSCLK0/TACLK2	I/O	2	DR0PRI/ TACLK4	I
3	TSCLK0/TACLK1	I/O	4	DT0PRI/SSEL2	O
5	CLK_out	O	6	SDA	I/O
7	PF4/TMR5/SSEL6 *	I/O	8	PF5/TMR4/SSEL5	I/O
9	Vin 3V3	PWR	10	Vin 3V3	PWR
11	PG0/PPI1D0	I/O	12	PG2/PPI1D2	I/O
13	PG4/PPI1D4	I/O	14	PG6/PPI1D6	I/O
15	PG8/PPI1D8/DR1SEC	I/O	16	PG10/PPI1D10/RSCLK1	I/O
17	PG12/PPI1D12/RE1PRI	I/O	18	PG14/PPI1D14/TFS1	I/O
19	PPI1SY3/PF7/TMR2	I/O	20	PPI1SY1/PF9/TMR0	I/O
21	PPI1SY1/PF9/TMR0	I/O	22	PF3/Rx1/TMR6/TACI6	I/O
23	PF1/DMAR1/TACI1/Rx0	I/O	24	PF11/MOSI	I/O
25	PF13/SCK	I/O	26	BMODE0	I
27	GND	PWR	28	TCK	I
29	TDI	I	30	nTRST	I
31	nEMU	O	32	TMS	I
33	TDO	O	34	BMODE2	I
35	N.C.	-	36	BMODE1	I
37	PF12/MISO	I/O	38	PF0/DMAR0/Tx0	I/O
39	PF14/SPI_SS	I/O	40	PF2/Tx1/TMR7	I/O
41	PPI1Clk/PF15/TMRCLK	I/O	42	PPI1Sy2/PF8/TMR1	I/O
43	PG15/PPI1D15/DT1PRI	I/O	44	PG13/PPI1D13/TSCLK1	I/O
45	PG11/PPI1D11/RFS1	I/O	46	PG9/PPI1D9/TD1SEC	I/O
47	PG7/PPI1D7	I/O	48	PG5/PPI1D5	I/O
49	PG3/PPI1D3	I/O	50	PG1/PPI1D1	I/O
51	GND	PWR	52	GND	PWR
53	PF5/TMR4/SSEL5	I/O	54	PF6/TMR3/SSEL4	I/O
55	PF10/SSEL1	I/O	56	SCL	I/O
57	DT0SEC/SSEL7/CANTx	O	58	TFS0/SSEL3	I/O
59	DR0SEC/TACI0/ CANRx	I	60	RFS0/TACLK3	I/O

Table 3-3: Connector P1 pin assignment

* Pin 7 (PF4) is by default internally connected to the address A21 of the flash memory (for addressing the upper 2MB of the 4MB Flash). If PF4 is needed and 2 MB flash are sufficient move resistor R16 to the position of R15 as shown in Figure 3-4.

3.5.2 Connector P2 – (61-120)

Pin No.	Signal	Signal type	Pin No.	Signal	Signal type
61	A1	O	62	A3	O
63	A5	O	64	A7	O
65	A9	O	66	A11	O
67	A13	O	68	A15	O
69	A17	O	70	A19	O
71	nABE1/SDQM0	O	72	LED_ACT	O
73	GND	-	74	RX+	I
75	RX-	I	76	ADRY	I
77	nBG	O	78	CLK_out	O
79	GND	PWR	80	nAMS3	O
81	nAWE	O	82	NMI	I
83	D0	I/O	84	D2	I/O
85	D4	I/O	86	D6	I/O
87	D8	I/O	88	D10	I/O
89	D12	I/O	90	D14	I/O
91	D15	I/O	92	D13	I/O
93	D11	I/O	94	D9	I/O
95	D7	I/O	96	D5	I/O
97	D3	I/O	98	D1	I/O
99	nReset	I	100	nAOE	O
101	nARE	O	102	nAMS2	O
103	VDD-RTC	PWR	104	nBGH	O
105	nBR	I	106	VA25	PWR
107	TX-	O	108	TX+	O
109	LED_FD	O	110	LED_SPEED	O
111	nABE0/SDQM0	O	112	A18	O
113	A16	O	114	A14	O
115	A12	O	116	A10	O
117	A8	O	118	A6	O
119	A4	O	120	A2	O

Table 3-4: Connector P2 pin assignment

3.5.3 Pin out Description

All pin names except those in Table 2-5 of the connectors are processor pins and correspond closely to the names found in the Blackfin BF537 datasheet from Analog Devices.

PIN Nr.	Name	Description
5,78	CLK_out	25MHz buffered clock output
9,10	Vin 3.3V	3V3 +/-10% 500mA peak for supply
35	nc	Not connected
72	LED_ACT	Indicates Ethernet activity
73	GND	AGND (use as GND for Ethernet connector and Ethernet passives)
74	RX+	Ethernet receive +
75	RX-	Ethernet receive -
106	VA25	Ethernet transformer voltage reference
107	TX-	Ethernet transmit -
108	TX+	Ethernet transmit +
109	LED_FD	Full duplex LED, High = Full duplex active, Low = inactive
110	LED_SPEED	10Mbps = Low, 100Mbps = High

Table 3-5: Pin description of all non Processor Pins on the CM-BF537E

All other pins are connected directly to the ADSP-BF537 processor.

3.6 RJ45 schematic

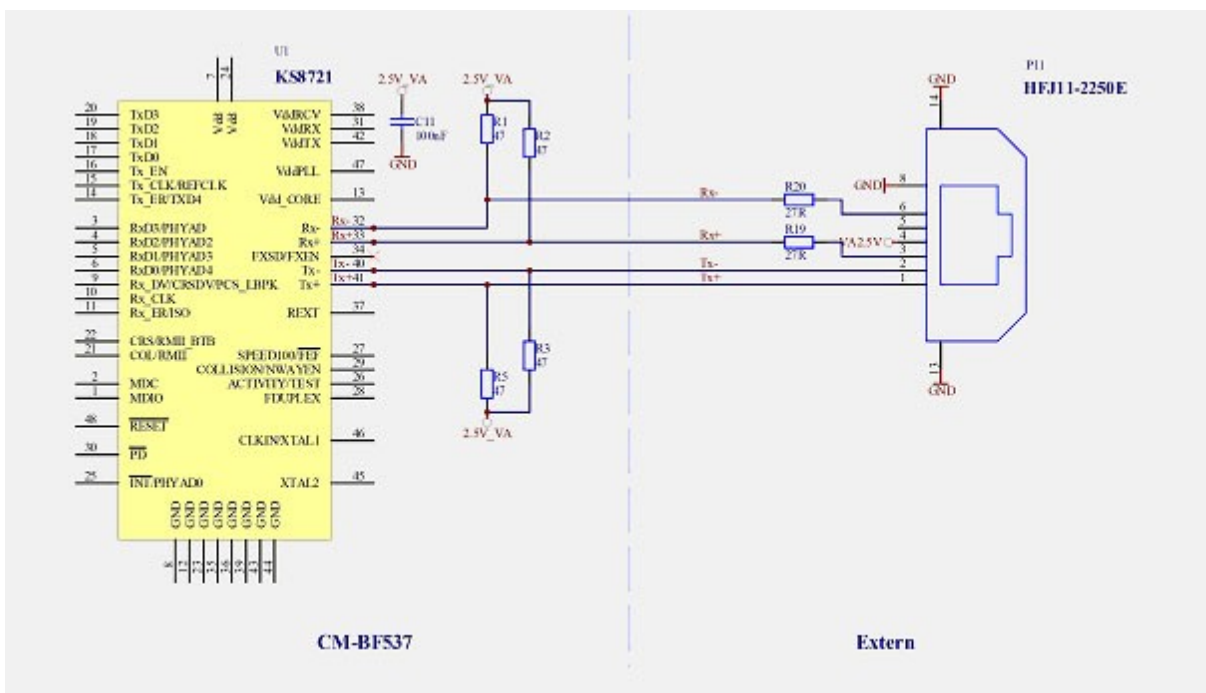

Figure 3-6: Schematic for RJ45 Connection

Designator	Value	Type	Description	Quantity
P11		HFJ11-2250E	RJ45 with transformer	1
R19, R20	27R		Resistor	2

Table 3-6: Parts List RJ45

4 Test Points

4.1 Footprint – Test Points

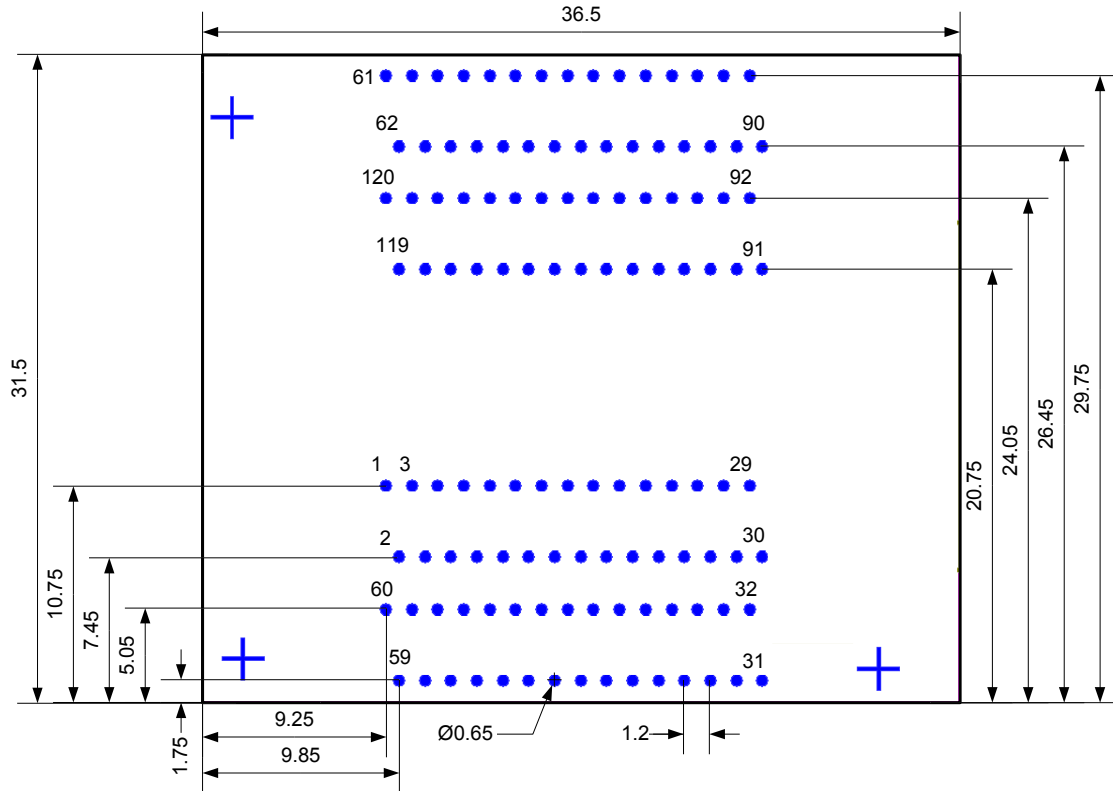

Figure 4-1: Test Points of the Core Module (top view)

5 Software Support

5.1 BLACKSheep

The Core Module is delivered with a pre-flashed basic version of the BLACKSheep VDK multithreaded framework. It contains a boot-loader for flashing the Core Module via the serial port.

The BLACKSheep for the CM-BF537E contains also a web server. By typing <http://192.168.0.10> you can see a standard web page installed on the Core Module.

Please mind the software development documents.

5.2 uClinux

The Core Module is supported by the open source platform at <http://blackfin.uclinux.org>. Since the Core Modules are pre-flashed with BLACKSheep you have to flash uBoot first. For flashing the uBoot you can use the BLACKSheep boot-loader.

6 Application Examples

6.1 Sample Schematic

In this minimum configuration the CM-BF537E is used as a high performance network connected processor module.

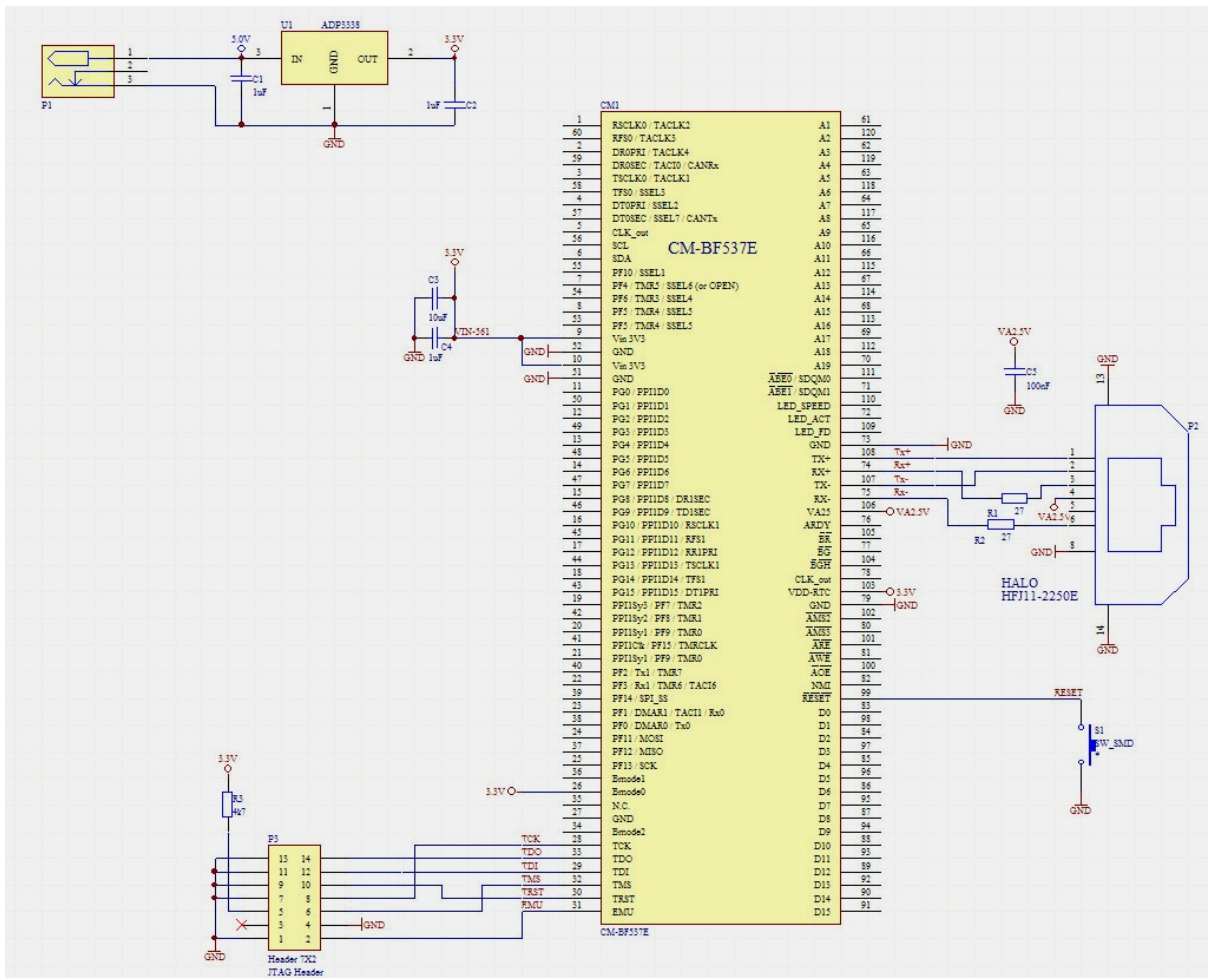

Figure 6-1: Configuration with Ethernet and JTAG Connector

Designator	Value	Type	Description	Quantity
C1, C2, C4	1uF		Capacitor	3
C3	10uF		Capacitor	1
C5	100nF		Capacitor	1
CM1			CM-BF537	1
P1		DC-8	Power connector DC-8	1
P2		HFJ11-2250E	RJ45 with transformer	1
P3			Header, 7-Pin, dual row	1
R1, R2	27		Resistor	2

R3	4k7		Resistor	1
S1			Switch	1
U1		ADP3338	Low dropout regulator	1

Table 6-1: Bill of Material of Sample Schematic

6.2 Stand-alone Ethernet based MPEG Webcam

The CM-BF537E module can be used as a stand-alone module for a camera system requiring only power supply and the direct attachment of a compatible video camera. A camera kit including drivers can be purchased from Bluetechnix: KIT-CAM-OV (O.Nr 100-9901)

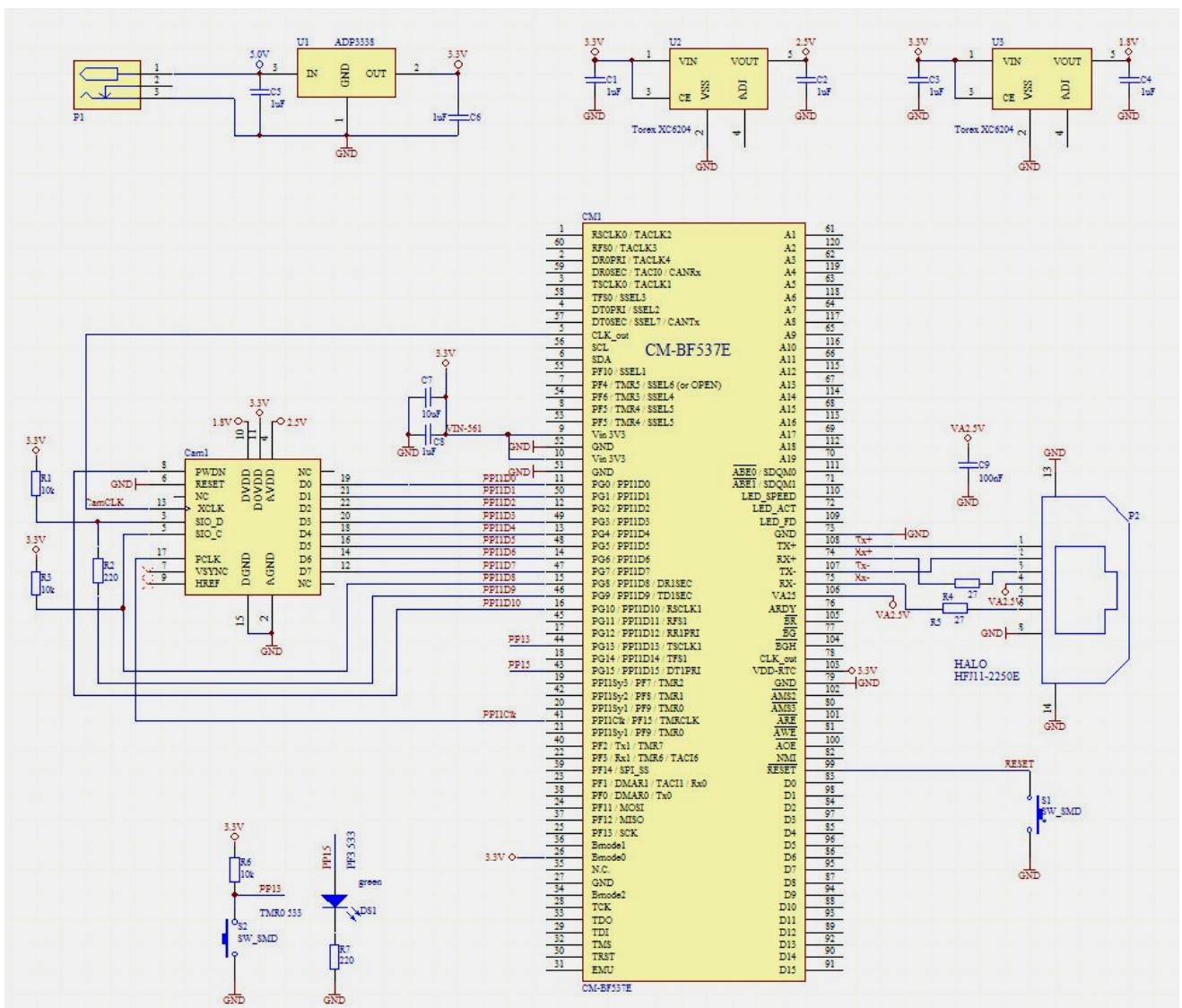

Figure 6-2: Stand-alone Ethernet based MPEG Webcam

Designator	Value	Type	Description	Quantity
C3, C4, C5, C6, C8	1u		Capacitor	6

C7	10u		Capacitor	1
C9	100n		Capacitor	1
Cam1		OV7660FSx	Camera module	1
CM1			CM-BF537	1
DS1	green		SMD LED	1
P1		DC-8	Power connector DC-8	1
P2		HFJ11-2250E	RJ45 with transformer	1
R2	220		Resistor	2
R1,R3	10k		Resistor	3
R4, R5	27		Resistor	2
S1, S2			Switch	1
U1		ADP3338	Low dropout regulator	1
U2		XC6204B252MR	XC6204 high speed LDO regulators	1
U3		XC6204B182MR	XC6204 high speed LDO regulators	1

Table 6-2: Bill of Material of a Stand-alone Ethernet based MPEG Webcam

6.3 Design Services

Bluetechnix offers custom design services and software development.

7 Known Bugs

	NONE

Table 7-1: Known Bugs

8 Product Changes

Version	Changes

Table 8-1: Product Changes

9 Document Revision History

Date	Document Revision
2007-05-03	Updated missing reference
2007-04-05	Several Changes and removing BGA option
2006-04-26	Updated Figures, Pin40 and PIN22 names
2006-04-02	Updated table 2-3 PF9 instead of P8, added VA25 on table 2-5 and fixed memory map in table 2-6
2005-10-13	Correct boot mode description
2005-10-11	New images
2005-08-16	Refinement of documentation
2005-06-28	First release V1.0 of the document

Table 9-1: Revision History

A List of Figures and Tables

Figures

Figure 1-1: Main components of the CM-BF537E Core Module	1
Figure 2-1: Detailed Block Diagram	3
Figure 3-1: Mechanical outline and Bottom Connectors (top view)	6
Figure 3-2: Side View with Connector mounted.....	6
Figure 3-3: Connector footprint for the Core Module (top view)	7
Figure 3-4: Core Module (component side)	8
Figure 3-5: Schematic Symbol of Module	9
Figure 3-6: Schematic for RJ45 Connection	13
Figure 4-1: Test Points of the Core Module (top view)	14
Figure 6-1: Configuration with Ethernet and JTAG Connector.....	16
Figure 6-2: Stand-alone Ethernet based MPEG Webcam	17

Tables

Table 2-1: Memory Map	4
Table 3-1: Baseboard connector types.....	7
Table 3-2: Module connector types.....	7
Table 3-3: Connector P1 pin assignment	10
Table 3-4: Connector P2 pin assignment	11
Table 3-5: Pin description of all non Processor Pins on the CM-BF537E.....	12
Table 3-6: Parts List RJ45	13
Table 6-1: Bill of Material of Sample Schematic.....	17
Table 6-2: Bill of Material of a Stand-alone Ethernet based MPEG Webcam	18
Table 7-1: Known Bugs	19
Table 8-1: Product Changes	20
Table 9-1: Revision History	21