

Rectangular Inductive Prox

TL-N



Space-Saving Sensors for a Wide Range of Applications

- Switches loads up to 200 mA
- Easy to install DC 2-wire models reduce wiring
- DC 3-wire models available with high-flexibility robotic cable
- DC types include mounting brackets





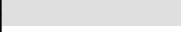

Ordering Information

■ DC 2-WIRE MODELS

Type	Sensing distance	Output form	Part number
Unshielded 	 7 mm (0.28 in)	NO	TL-N7MD1
		NC	TL-N7MD2
	 12 mm (0.47 in)	NO	TL-N12MD1
		NC	TL-N12MD2
	 20 mm (0.79 in)	NO	TL-N20MD1
		NC	TL-N20MD2

Note: Models that are different in response frequency are available for the prevention of mutual interference. Add a "5" to the end of the part numbers above (e.g. TL-N7MD15).

■ DC 3-wire and AC 2-wire Models

Type	Sensing distance	Output form	Part number		
Unshielded Rectangular 	 5 mm (0.20 in)	DC 3-wire	NPN NO	TL-N5ME1 (See Notes 2 and 3.)	
			NPN NC	TL-N5ME2 (See Notes 2 and 3.)	
		AC 2-wire	NO	TL-N5MY1	
			NC	TL-N5MY2	
		 10 mm (0.39 in)	DC 3-wire	NPN NO	TL-N10ME1 (See Notes 2 and 3.)
				NPN NC	TL-N10ME2 (See Notes 2 and 3.)
	AC 2-wire		NO	TL-N10MY1	
			NC	TL-N10MY2	
	 20 mm (0.79 in)	DC 3-wire	NPN NO	TL-N20ME1 (See Notes 2 and 3.)	
			NPN NC	TL-N20ME2 (See Notes 2 and 3.)	
		AC 2-wire	NO	TL-N20MY1	
			NC	TL-N20MY2	

Note: 1. Models that are different in response frequency are available for the prevention of mutual interference. Add "5" to the end of the part numbers above (e.g. TL-N5ME15).

2. Each of these models has a cable with a standard length of 5 m.

3. Each of these models with a robotic cable is available and classified with the suffix "R" added to the model number (e.g., TL-N5ME1-R).

■ ACCESSORIES

Description	Part number	
Mounting brackets (supplied with DC sensors; order separately for AC sensors)	Fits TL-N5 and TL-N7 sensors	Y92E-C5
	Fits TL-N10 and TL-N12 sensors	Y92E-C10
	Fits TL-N20 sensors	Y92E-C20

Specifications

■ RATINGS/CHARACTERISTICS

TL-N□MD DC 2-wire Models

Item	TL-N7MD□	TL-N12MD□	TL-N20MD□
Supply voltage (operating voltage range)	12 to 24 VDC (10 to 30 VDC), ripple (p-p): 10% max.		
Leakage current	0.8 mA max.		
Sensing object	Ferrous metal (Refer to <i>Engineering Data</i> for non-ferrous metal)		
Sensing distance	7 mm ±10% (0.28 in)	12 mm ±10% (0.47 in)	20 mm ±10% (0.79 in)
Sensing distance (standard object)	0 to 5.6 mm (0.22 in) (iron, 30 x 30 x 1 mm)	0 to 9.6 mm (0.38 in) (iron, 40 x 40 x 1 mm)	0 to 16 mm (0.63 in) (iron, 50 x 50 x 1 mm)
Differential travel	10% max. of sensing distance		
Response frequency (See Note.)	0.5 kHz		0.3 kHz
Operating status (with sensing object approaching)	D1 models: Load ON D2 models: Load OFF		
Control output (switching capacity)	3 to 100 mA DC		
Circuit protection	Load short-circuit protection and surge absorber		
Indicator	D1 models: Operation indicator (red LED) and setting indicator (green LED) D2 models: Operation indicator (red LED)		
Ambient temperature	Operating	-25°C to 70°C (-13°F to 158°F) with no icing	
Ambient humidity	Operating	35% to 95%	
Temperature influence	±10% max. of sensing distance at 23°C (73.4°F) in the temperature range of -25°C to 70°C (-13°F to 158°F)		
Voltage influence	±2.5% max. of sensing distance within a range of ±15% of the rated power supply voltage		
Residual voltage	3.3 V max. with a load current of 100 mA and a cord length of 2 m (78.7 in)		
Insulation resistance	50 MΩ min. (at 500 VDC) between current carry parts and case		
Dielectric strength	1,000 VAC for 1 min between current carry parts and case		
Vibration resistance	10 to 55 Hz, 1.5-mm double amplitude for 2 hours each in X, Y, and Z directions		
Shock resistance	1,000 m/s ² (3280.8 ft/sec ²) approx. 100G for 10 times each in X, Y, and Z directions		
Degree of protection	IEC60529 IP67		
Weight (with 2-m cable)	Approx. 145 g (5.11 oz)	Approx. 170 g (5.99 oz)	Approx. 240 g (8.46 oz)
Material	Case	Heat-resistant ABS resin	
	Sensing surface	Heat-resistant ABS resin	

Note: Response frequencies are average values measured with identical standard sensing objects, on condition that the space between any adjacent sensing objects was twice the width of a single sensing object and the setting distance was half the maximum sensing distance. Refer to *Precautions* for details.

■ DC 3-WIRE AND AC 2-WIRE MODELS

Item		TL-N5ME□, TL-N5MY□	TL-N10ME□, TL-N10MY□	TL-N20ME□, TL-N20MY□
Supply voltage (operating voltage range) (See Note.)		E models: 12 to 24 VDC (10 to 30 VDC), ripple (p-p): 10% max. Y models: 100 to 220 VAC (90 to 250 VAC), 50/60 Hz		
Current consumption		E models: 8 mA at 12 V, 15 mA at 24 V		
Leakage current		Y models: Refer to <i>Engineering Data</i> .		
Sensing object		Ferrous metal (Refer to <i>Engineering Data</i> for non-ferrous metal)		
Sensing distance		5 mm ±10% (0.20 in)	10 mm ±10% (0.39 in)	20 mm ±10% (0.79 in)
Setting distance (standard object)		0 to 4 mm (0.16 in) (iron, 30 x 30 x 1 mm)	0 to 8 mm (0.31 in) (iron, 40 x 40 x 1 mm)	0 to 16 mm (0.63 in) (iron, 50 x 50 x 1 mm)
Differential travel		1% to 15% of sensing distance		
Response frequency (See Note.)		E models: 500 Hz Y models: 10 Hz		E models: 40 Hz Y models: 10 Hz
Operating status (with sensing object approaching)		E1 models: L output signal with load ON E2 models: H output signal with load OFF Y1 models: Load ON Y2 models: Load OFF		
Control output (switching capacity)		E models: 100 mA max. at 12 VDC and 200 mA max. at 24 VDC Y models: 10 to 200 mA		
Circuit protection		E models: Reverse connection protection and surge absorber Y models: Surge absorber		
Ambient temperature	Operating	-25°C to 70°C (-13°F to 158°F) with no icing		
Ambient humidity	Operating	35% to 95%		
Temperature influence		±10% max. of sensing distance at 23°C (73.4°F) in the temperature range of -25°C to 70°C (-13°F to 158°F)		
Voltage influence		E models: ±2.5% max. of sensing distance within a range of ±10% of the rated power supply voltage Y models: ±1% max. of sensing distance within a range of ±10% of the rated power supply voltage		
Residual voltage		E models: 1 V max. with a current of 200 mA Y models: Refer to <i>Engineering Data</i> .		
Insulation resistance		50MΩ min. at 500 VDC between current carry parts and case		
Dielectric strength		DC models: 1,000 VAC, 50/60 Hz for 1 min between current carry parts and case AC models: 2,000 VAC, 50/60 Hz for 1 min between current carry parts and case		
Vibration resistance		10 to 55 Hz, 1.5-mm double amplitude for 2 hours each in X, Y, and Z directions		
Shock resistance		500 m/s ² (1640.4 ft/sec ²) approx. 50G for 10 times each in X, Y, and Z directions		
Degree of protection		IEC IP67		
Weight (with 2-m cable)		Approx. 145 g (5.11 oz)	Approx. 170 g (5.99 oz)	Approx. 240 g (8.46 oz)
Material	Case	Heat-resistant ABS resin		
	Sensing surface	Heat-resistant ABS resin		

Note: The E models (DC switching type) can be used with a full-wave rectification power of 24 VDC ±10%.

Operation

OUTPUT CIRCUITS

DC 2-wire Models

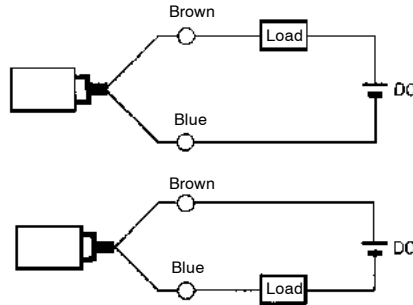
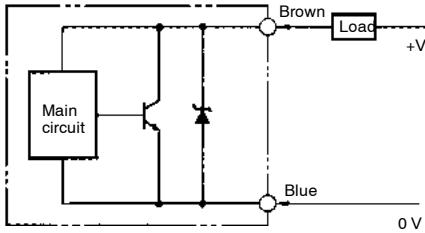

Note: The load can be connected in two ways as shown in the above diagrams.

TIMING CHARTS

Normally Open Model

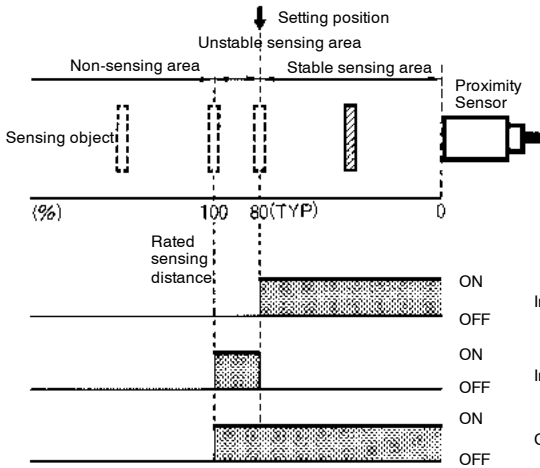

Normally Closed Model

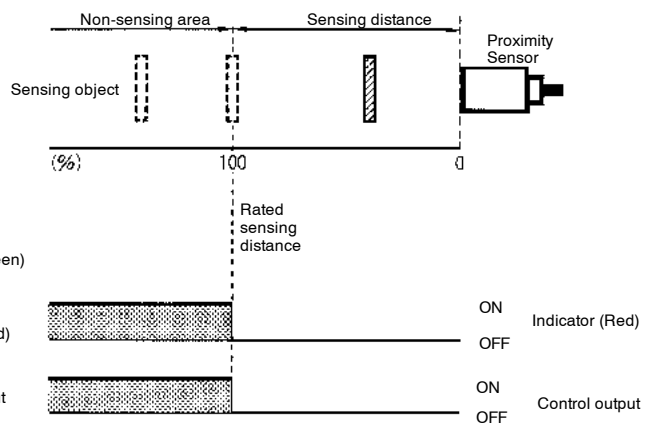

DC 3-wire Models

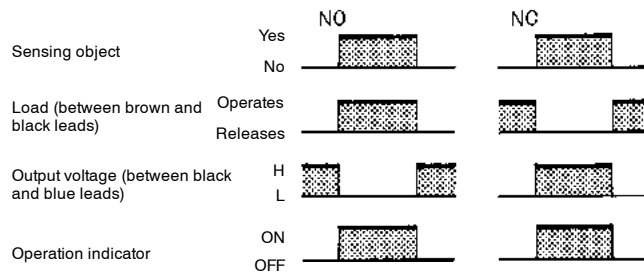
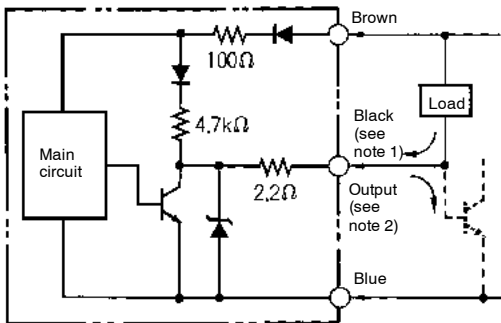

- Note: 1. 200 mA max. (load current)
- 2. When a transistor is connected.

■ DC 3-WIRE AND AC 2-WIRE SENSORS

TL-N5MY

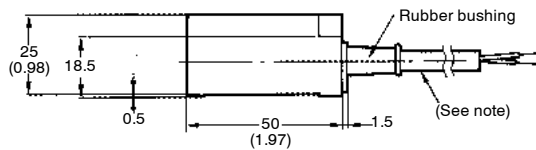
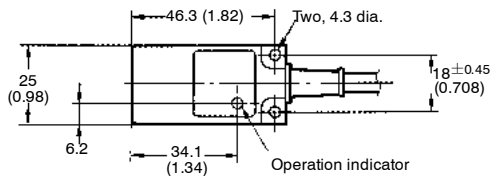
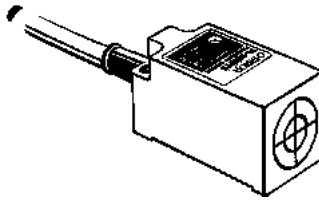

Note: Vinyl-insulated round cable, oil- and vibration-resistant, 0.5 mm², 2 cores, 6 dia.; standard length: 2 m

TL-N5ME

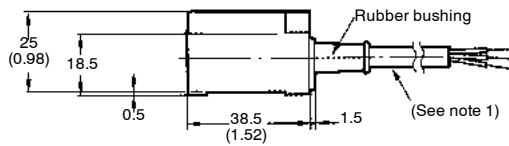
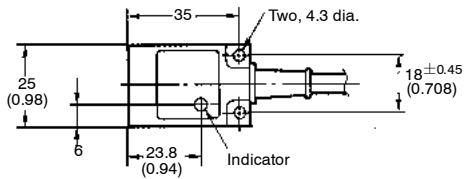
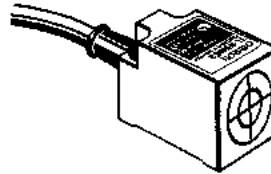

Note: 1. Vinyl-insulated round cable, oil- and vibration-resistant, 0.5 mm², 3 cores, 6 dia.; standard length: 5 m
2. The Y92E-C5 Mounting Bracket is provided with the TL-N5ME.

TL-N10ME/N10MY

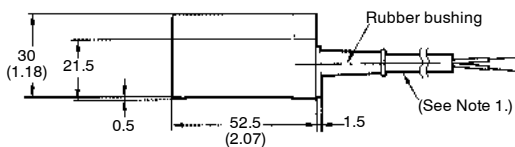
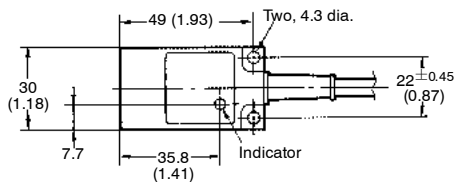
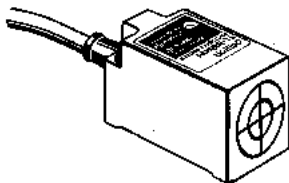

Note: 1. Vinyl-insulated round cable, oil- and vibration-resistant, 0.5-mm², 6 dia., 2 cores for TL-N10MY, 3 cores for TL-N10ME.
2. The Y92E-C10 Mounting Bracket is provided with the TL-N10ME□.

TL-N20ME/N20MY

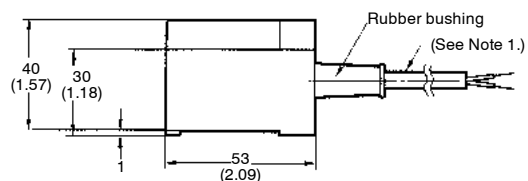
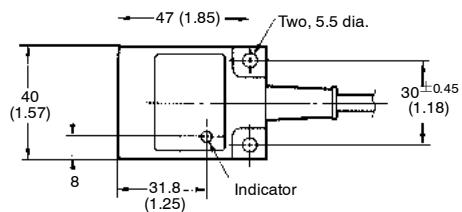
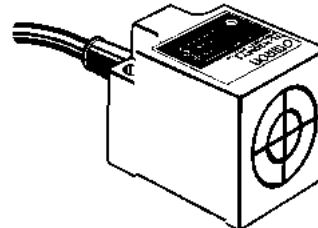

Note: 1. Vinyl-insulated round cable, oil- and vibration-resistant, 0.5-mm², 6 dia., 2 cores for TL-N20MY, 3 cores for TL-N20ME.
2. The Y92E-C20 Mounting Bracket is provided with the TL-N20ME□.

■ MOUNTING HOLES

TL-N5ME/N5MY/N7MD

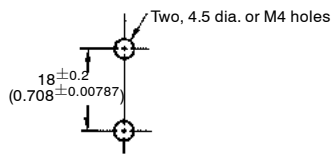

TL-N10ME/N10MY/N12MD

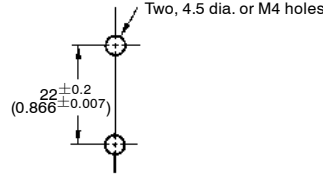

TL-N20ME/N20MY/N20MD

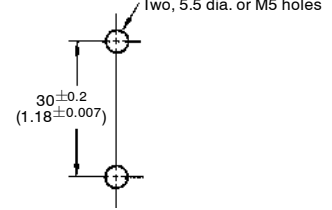

■ MOUNTING BRACKETS

The Mounting Bracket is provided with TL-ME□/D□ DC models. The Mounting Bracket as an optional accessory is available to all models.

Y92E-C5

Applicable Models: TL-N5ME, TL-N5MY, and TL-N7MD

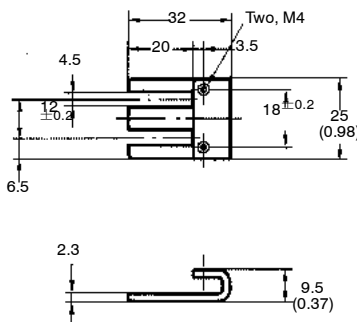

Y92E-C10

Applicable Models: TL-N10ME, TL-N10MY, and TL-N12MD

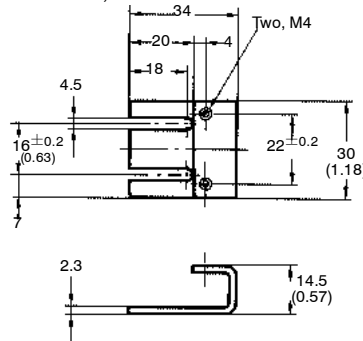

Y92E-C20

Applicable Models: TL-N20ME, TL-N20MY, and TL-N20MD

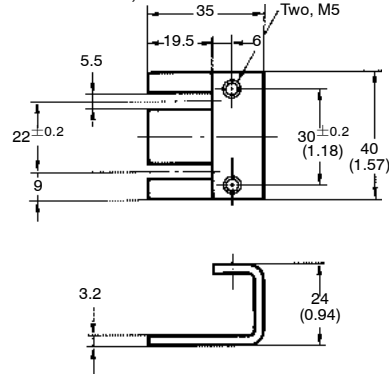

■ MOUNTING BRACKETS FOR WIRING CONDUIT USE (SOLD SEPARATELY)

Y92E-N5C15

Applicable Models: TL-N5ME and TL-N5MY

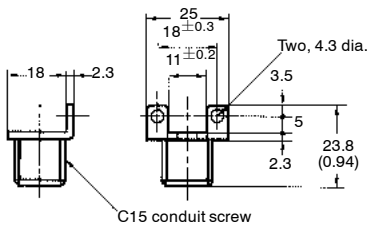

Y92E-N10C15

Applicable Models: TL-N10ME and TL-N10MY

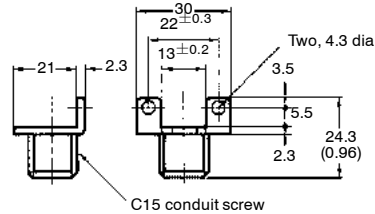

Precautions

■ WARNINGS

Do not short-circuit the load, to avoid damaging the TL-N.

Do not supply power to the TL-N with no load, or the TL-N may be damaged.

Applicable Models: AC 2-wire models

■ EFFECTS OF SURROUNDING METALS

When the TL-N is surrounded by metal, keep the following distances as a minimum between the TL-N and the metal. (Refer to the table below.)

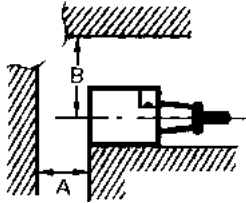

Minimum Distances for Surrounding Metals

Distance	TL-N7MD□	TL-N12MD□	TL-N20MD□	TL-N5ME□ TL-N5MY□	TL-N10ME□ TL-N10MY□	TL-N20ME□ TL-N20MY□
A (See Note.)	40 mm (1.57 in)	50 mm (1.97 in)	70 mm (2.75 in)	20 mm (0.79 in)	40 mm (1.57 in)	80 mm (3.15 in)
B (See Note.)	35 mm (1.37 in)	40 mm (1.57 in)	60 mm (2.36 in)	23 mm (0.91 in)	30 mm (1.18 in)	45 mm (1.77 in)

Note: The figures are applicable for one metal object, or the figure must be multiplied by the number of metal objects.

■ MUTUAL INTERFERENCE

When two or more Sensors are mounted face-to-face or side-by-side, keep them separated at the following distances or greater. (Refer to the next two tables.)

Side-by-Side

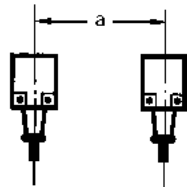

Face-to-Face

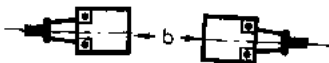

Same Frequency Type

Distance	TL-N7MD□	TL-N12MD□	TL-N20MD□	TL-N5ME□	TL-N5MY□	TL-N10ME□ TL-N10MY□	TL-N20ME□ TL-N20MY□
a	100 mm (3.94 in)	120 mm (4.72 in)	200 mm (7.87 in)	80 mm (3.15 in)	80 mm (3.15 in)	120 mm (4.72 in)	200 mm (7.87 in)
b	120 mm (4.72 in)	200 mm (7.87 in)	300 mm (11.81 in)	80 mm (3.15 in)	90 mm (3.54 in)	120 mm (4.72 in)	200 mm (7.87 in)

These figures will apply if the Sensors in use are different from each other in response frequency.