

# Enpirion EN6337QI/EN6347QI DC-DC Converter w/Integrated Inductor Evaluation Board

## Introduction

Thank you for choosing Enpirion, the source for ultra small foot print power converter products! This evaluation board user guide applies to two products with identical pinouts: The EN6337QI is a 3A device, and the EN6347QI is a 4A device. The term EN63x7QI will refer to both products throughout this document. This evaluation board user guide applies to the EN63x7-03 engineering devices. In addition to this document, you will also need the latest device datasheet.

- The EN63x7QI features integrated inductor, power MOSFETS, controller, a bulk of the compensation network, and protection circuitry against system faults. This level of integration delivers a substantial reduction in footprint and parts count over competing solutions. The evaluation board is optimized for engineering ease of testing through programming options, clip leads, test points etc.
- The EN63x7QI features a customer programmable output voltage by means of a resistor divider. The resistor divider allows the user to set the output voltage to any value within the range 0.75V to  $(V_{IN}-V_{DROPOUT})$ . The evaluation board, as shipped is populated with a 4 resistor divider option. The upper resistor is fixed and has a phase lead capacitor in parallel. One of the 4 lower resistors is selected with the jumper option for different output voltages to change  $V_{OUT}$ , retain the upper resistor and capacitor values and change only the lower resistor.
- This device has no over-voltage protection feature. We strongly recommend the customer to ensure the feedback loop is truly closed before powering up the device especially if the load can not withstand the input voltage.
- The input and output capacitors are X5R or X7R multi-layer ceramic chip capacitors. The Soft-start capacitor is a small 15nF X7R MLCC. Pads are available to have multiple input and output capacitors. This allows for evaluation of performance over a wide range of input/output capacitor combinations.
- Clip-on terminals are provided for ENA, SS, POK, and LLM pins.
- Banana jacks are provided for  $V_{IN}$  and  $V_{OUT}$  power terminals. Several signal and GND clip-on test points are also provided to measure  $V_{IN}$ ,  $V_{OUT}$ , and GND nodes.

- A jumper is provided for controlling the Enable signal. Enable may also be controlled using an external switching source by removing the jumper and applying the enable signal to the ENA clip-on terminal.
- A jumper is also provided to connect the POK pull-up resistor to the input supply. This jumper is especially useful to measure the disable current and eliminates having to subtract the current drawn by the POK resistor.
- A jumper is provided for controlling the LLM/SYNC pin. This pin can be high for automatic LLM (light-load mode) operation. If it is pulled low, the part will be in PWM mode only.
- Foot print is also provided for a SMA connector to LLM/SYNC input. A switching input to this pin allows the device clock to be phase locked to an external signal. This external clock synchronization allows for moving any offending beat frequency to be moved out-of-band. A swept frequency applied to this pin results in spread spectrum operation and reduces the peaks in the noise spectrum of emitted EMI.
- The board comes with input decoupling and reverse polarity protection to guard the device against common setup mishaps.

## Quick Start Guide

**STEP 1:** Set the “ENABLE” jumper to the Disable Position, as shown in Figure 1.

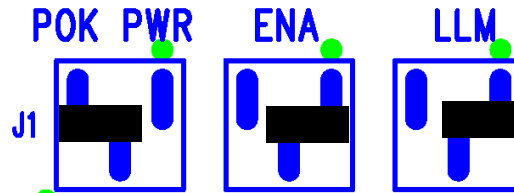

Figure 1: Shows POK, Enable, and LLM Jumpers. POK PWR jumper as shown connects pull-up resistor to VIN. Enable jumper shown in DISABLE position. LLM jumper as shown disables LLM operation.

**STEP 2:** Connect Power Supply to the input power connectors, VIN (+) and GND (-) as indicated in Figure 1 and set the supply to the desired voltage. The device disable current may be measured in this configuration.

**CAUTION:** be mindful of the polarity. Even though the evaluation board comes with reverse polarity protection diodes, it may not protect the device under all conditions.

**STEP 3:** Connect the load to the output connectors VOUT (+) and GND (-), as indicated in Figure 1.

**STEP 4:** Select the output voltage setting jumper. Figure 2 shows what output voltages are achieved by selecting each jumper position. Populating multiple jumper positions will allow you to select higher output voltages. You can populate up to all four jumper positions for the highest  $V_{OUT}$  of approximately 3.73V with the resistors populated on the board.

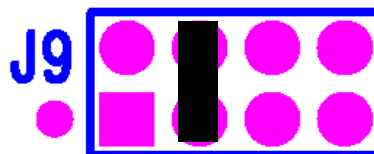

Figure 2: Output Voltage selection jumpers  
Jumper shown selects 1.55V output  
(Jumper positions from left to right are: 2.25V, 1.55V, 1.2V and 1.0V)

**STEP 5:** Set the POK PWR and LLM jumpers to desired positions (see Figure 1). You should disable POK when measuring low value input currents.

**STEP 6:** Apply  $V_{IN}$  to the board and move the ENA jumper to the enabled position. The EN63x7QI is now powered up! Various measurements such as efficiency, line and load regulation, input / output ripple, load transient, drop-out voltage measurements may be

conducted at this point. The over current trip level, short circuit protection, under voltage lock out thresholds, temperature coefficient of the output voltage may also be measured in this configuration.

**CAUTION: The maximum allowable VIN for this version of devices is 6.6V.**

**STEP 6A: Power Up/Down Behavior** – Remove ENA jumper and connect a pulse generator (output disabled) signal to the clip-on test point below ENA and Ground. Set the pulse amplitude to swing from 0 to 2.5 volts. Set the pulse period to 10msec. and duty cycle to 50%. Hook up oscilloscope probes to ENA, SS, POK and VOUT with clean ground returns. Apply power to evaluation board. Enable pulse generator output. Observe the SS capacitor and VOUT voltage ramps as ENA goes high and again as ENA goes low. The device when powered down ramps down the output voltage in a controlled manner before fully shutting down. The output voltage level when POK is asserted /de-asserted as the device is powered up / down may be observed as well as the clean output voltage ramp and POK signals.

**STEP 7: External Clock Synchronization / Spread Spectrum Modes:** In order to activate this mode, it may be necessary to solder a SMA connector at J8. Alternately the input clock signal leads may be directly soldered to the through holes of J8 as shown below.

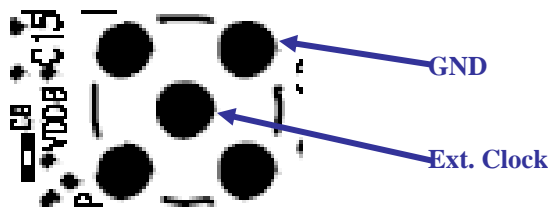

**Figure 3: SMA Connector for External Clock Input**

Power down the device. Move ENA into disable position. Connect the clock signal as just indicated. The clock signal should be clean and have a frequency in the range of the nominal frequency  $\pm 15\%$ ; amplitude 0 to 2.5 volts with a duty cycle between 20 and 80%. With SYNC signal disabled, power up the device and move ENA jumper to Enabled position. The device is now powered up and outputting the desired voltage. The device is switching at its free running frequency. The switching waveform may be observed between test points SW and GND. Now enabling the SYNC signal will automatically phase lock the internal switching frequency to the externally applied frequency as long as the external clock parameters are within the specified range. To observe phase-lock connect oscilloscope probes to the input clock as well as to the SW test point. Phase lock range can be determined by sweeping the external clock frequency up / down until the device just goes out of lock at the two extremes of its range.

For spread spectrum operation the input clock frequency may be swept between two frequencies that are within the lock range. The sweep (jitter) repetition rate should be limited to 10 kHz. The radiated EMI spectrum may be now measured in various states – free running, phase locked to a fixed frequency and spread spectrum. Before measuring radiated EMI, place a 10uF/0805, X7R capacitor at the input and output edges of the PCB (footprint already provided on the board), and connect the input power and the load to the board at or near these capacitors. The added capacitor at the input edge is for high-frequency decoupling of the input cables. The one added at the output edge is meant to represent a typical load decoupling capacitor.

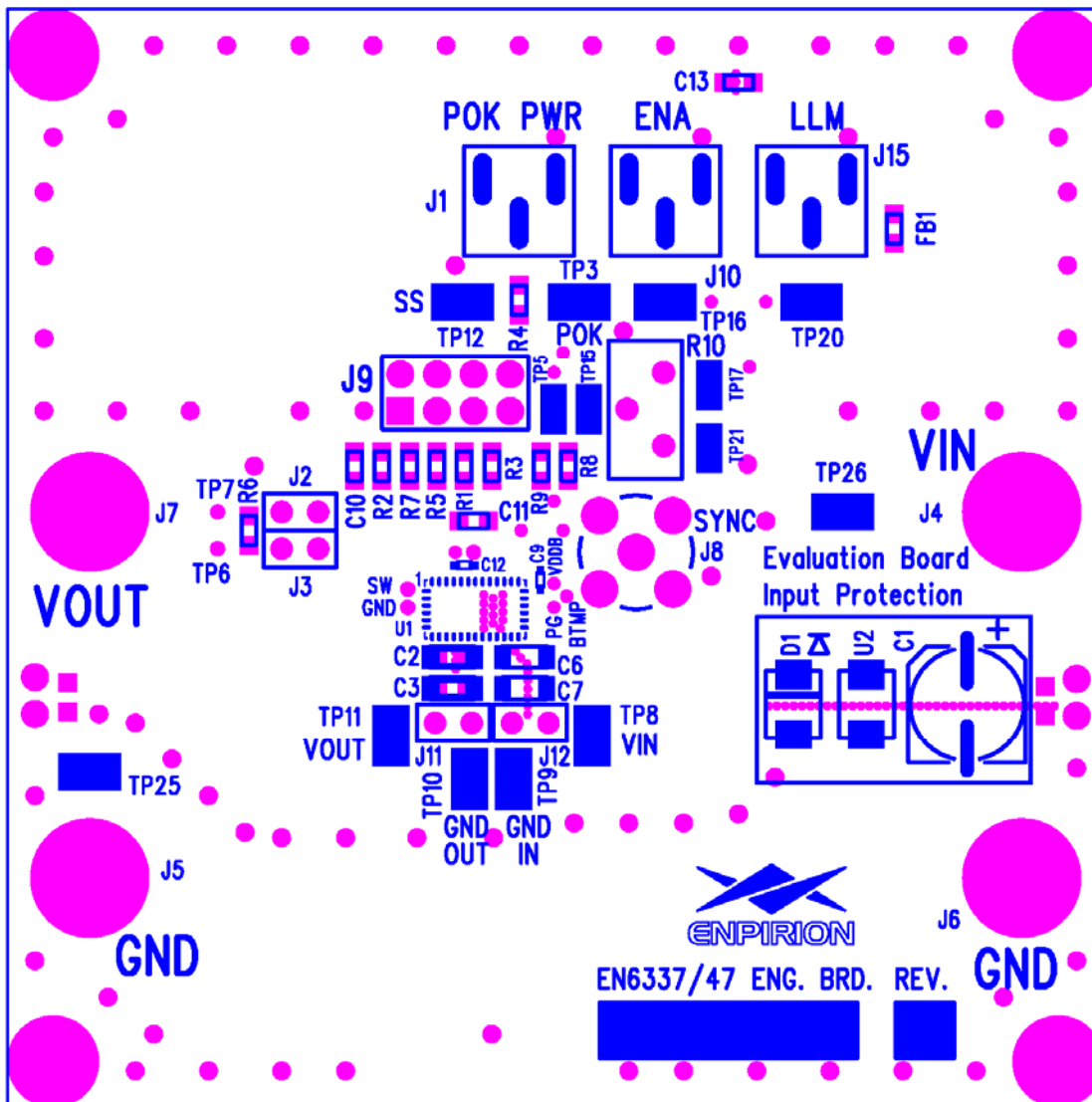

**Figure 4: Evaluation Board Layout Assembly Layer**

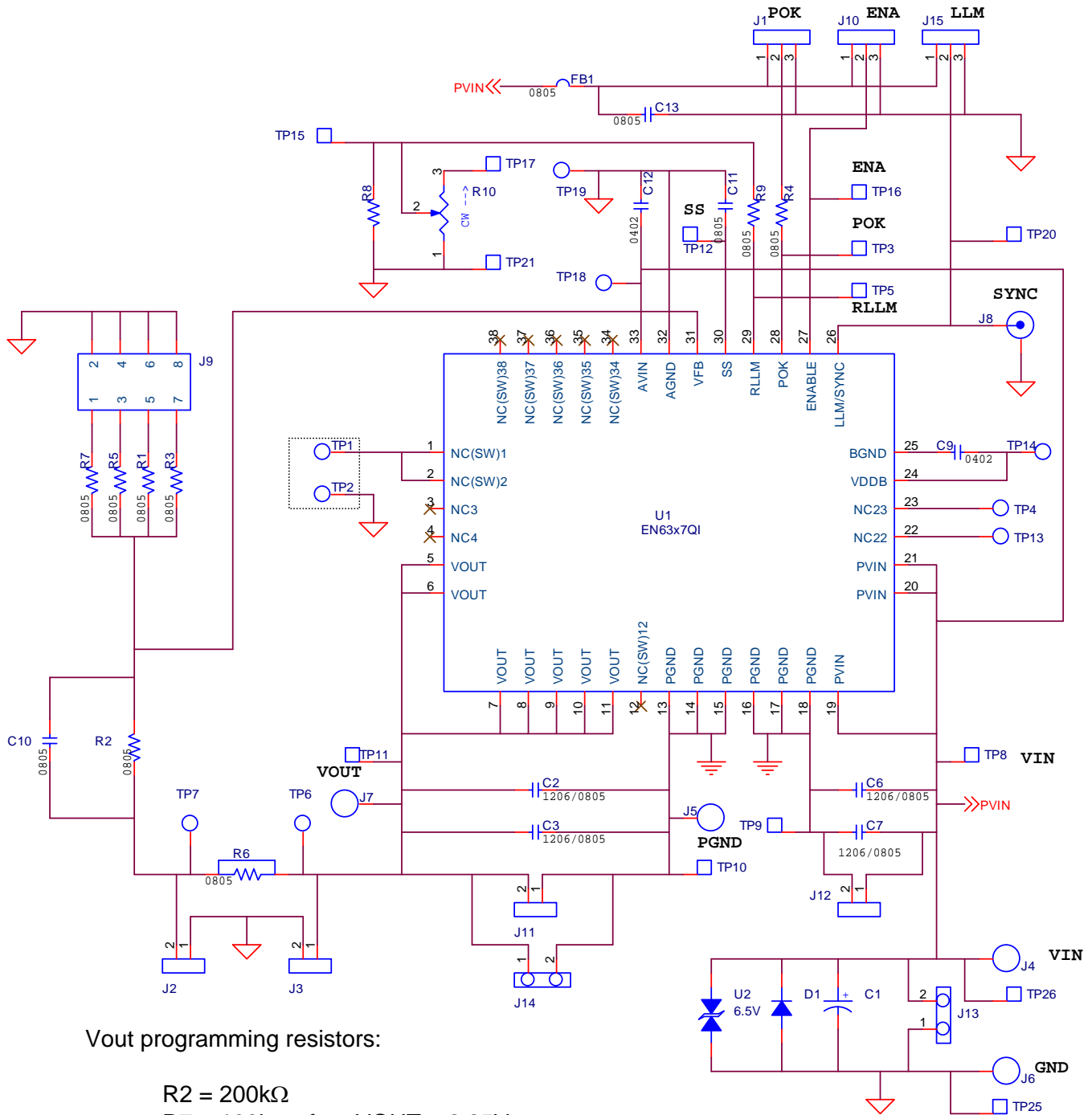
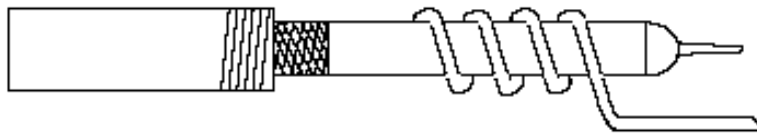

**Figure 5: EN63x7 Evaluation Board Schematic**

## Test Recommendations

To guarantee measurement accuracy, the following precautions should be observed:

1. Make all input and output voltage measurements at the board using the test points provided (TP8 to TP11). This will eliminate voltage drop across the line and load cables that can produce false readings.
2. Measure input and output current with series ammeters or accurate shunt resistors. This is especially important when measuring efficiency.
3. Use a low-loop-inductance scope probe tip shown below to measure switching signals and input / output ripple to avoid noise coupling into the probe ground lead. Input ripple, output ripple, and load transient deviation are best measured near the respective input / output capacitors. For more accurate ripple measurement, please see Enpirion App Note regarding this subject.



4. The board includes a pull-up resistor for the POK signal and ready to monitor the power OK status at clip lead marked POK.
5. A 15nF soft-start capacitor is populated on the board for ~1msec soft-start time.
6. The over-current protection circuit typically limits the maximum load current to approximately 1.5X the rated value.

## Input and Output Capacitors

Please refer to the BOM section for the value of input caps and output caps used on this evaluation board, which is the result of combination for better performance and smaller footprints.

**NOTE:** Capacitors must be X5R or X7R dielectric formulations to ensure adequate capacitance over operating voltage and temperature ranges.

## Bill of Materials

Designator	Qty	Description	
C1	1	CAP, SMT ELECTROLYTIC, 150UF, 20%, 10V	
C2	1	CAP, CER 47UF 10V X5R 1206	
C3, C13	2	CAP, 10UF 0805 X7R 10% 10V CERAMIC	
C6	1	CAP, CER 22UF 10V X5R 1206	
C10	1	EN6337QI Evaluation Board	CAP, 15PF 50V CERM CHIP 0805 SMD
		EN6347QI Evaluation Board	CAP, CERM 10PF 5% 50V NP0 0805
C11	1	15000PF 10% 50V SMD 0805 X7R CERAMIC CHIP CAPACITOR	
C7, C9, C12, J2, J3, J8, J11, J12, R6, R10	10	NOT USED	
D1	1	S2A DIODE	
FB1	1	MULTILAYER SMD FERRITE BEAD 4000MA 0805 L=TYPICAL (NOT GUARANTEED)	
J1, J10, J15	3	CONN, VERTICAL, 3 POSITION, SMT	
J4-J7	4	BANANA JACK	
J9	1	CONNECTOR HEADER 8 POS .100" STR TIN	
R1	1	RES 332K OHM 1/8W 1% 0805 SMD	
R2	1	RES 200K OHM 1/8W 0.1% 0805 SMD	
R3	1	RES 604K OHM 1/8W 1% 0805 SMD	
R4	1	RES 100K OHM 1/8W 1% 0805 SMD	
R5	1	RES 187K OHM 1/8W 1% 0805 SMD	
R7	1	RES 100K OHM 1/8W 0.1% 0805 SMD	
R8	1	EN6337QI	RES 75.0K OHM 1/8W 1% 0805 SMD
		EN6347QI	RES 60.4K OHM 1/8W 0.1% 0805 SMD
R9	1	THICK FILM RESISITOR 0 OHM 1/8W 5% 0805 SMD	
TP3, TP5, TP8-TP12, TP15-TP17 TP20, TP21, TP25, TP26	14	TEST POINT SURFACE MOUNT	
U1	1	EN6337QI Evaluation Board	EN6337QI 3A GOOD TESTED PRODUCT USING 6337-06 DIE- FIX IN THE LLM FILTER LOGIC (GOLD WIRE)
		EN6347QI Evaluation Board	EN6347QI 4A GOOD TESTED PRODUCT USING 6347-06 DIE-SOFT-SHORT FIX (COPPER WIRE)
U2	1	TRANSIENT VOLTAGE SUPPRESSOR, 6.5V, BIDIRECTIONAL, SMT	





## Contact Information

Enpirion, Inc.  
Perryville III  
53 Frontage Road - Suite 210  
Hampton, NJ 08827 USA  
Phone: +1-908-894-6000  
Fax: +1.908-894-6090  
[www.enpirion.com](http://www.enpirion.com)

*Enpirion reserves the right to make changes in circuit design and/or specifications at any time without notice. Information furnished by Enpirion is believed to be accurate and reliable. Enpirion assumes no responsibility for its use or for infringement of patents or other third party rights, which may result from its use. Enpirion products are not authorized for use in nuclear control systems, as critical components in life support systems or equipment used in hazardous environments without the express written authority from Enpirion.*