



Low Power Consumption Fan San Ace 92
 Square type : 92mm Thick : 38mm

PDF

The PDF file of this product can be downloaded.

PWM Control, Pulse sensor, Ribbed Features

Material	Frame: Plastics (Flammability: UL94V-0) Impeller: Plastics (Flammability:Min.UL94V-1) 40,000h/60°C, 70,000h/40°C: 9GA0912P1H03 Expected life at 40°C ambient is just reference value.
Life Expectancy	----- 40,000h/60°C: 9GA0948P1H03 (L10: Survival rate: 90%, rated voltage, and continuously run in a free air state)
Motor Protection System	Current blocking function and Reverse polarity protection
Dielectric Strength	50/60 Hz, 500VAC, 1 minute (between lead conductor and frame)
Sound Pressure Level (SPL)	Expressed as the value at 1m from air inlet side
Storage Temperature	-30 to +70 °C (Non-condensing)
Operating Temperature	----- -10 to +70 °C
Lead Wire	(+): red (-): black Sensor: yellow Control: brown

Specifications

Model No.	Rated Voltage (V)	Operating voltage range (V)	Rated current (A)	Rated input (W)	Rated speed (min ⁻¹)	Air flow (m ³ /min)	Static pressure (Pa)	Noise (dB[A])	Mass (g)
9GA0948P1H03	48	40.8 to 55.2	0.55	26.4	9,700 (PWM Duty 100%)	4.00 (141 CFM)	500 (2.01 inchH2O)	63	240

Note 1: Rated voltage 48V fans do not rotate when PWM duty cycle is 0%.
 ※PWM Frequency : 25kHz

Air Flow and Static Pressure Characteristics

PWM Duty Cycle

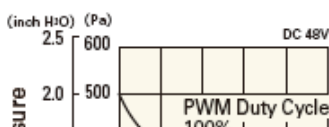

Operating Voltage Range

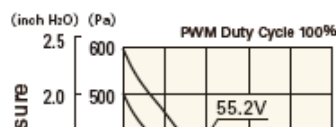

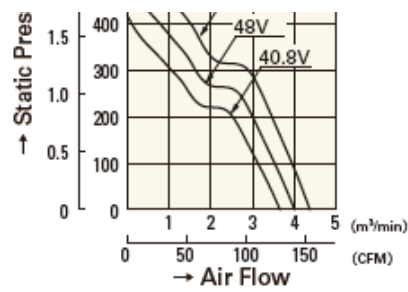
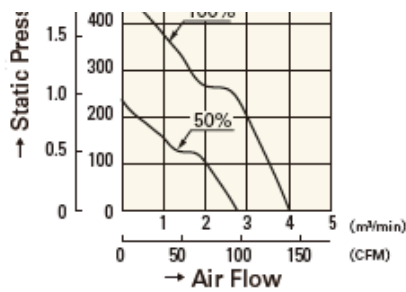

PWM Duty - Speed Characteristics Example

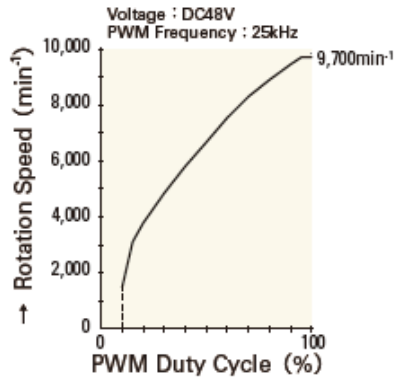

Dimensions (unit : mm) (With ribs)

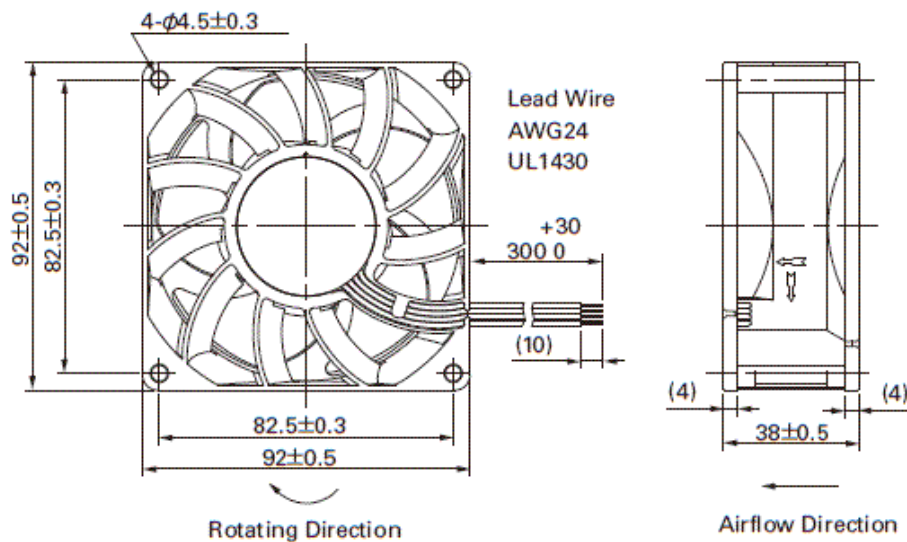

■ Reference dimension of mounting holes and vent opening (unit : mm)

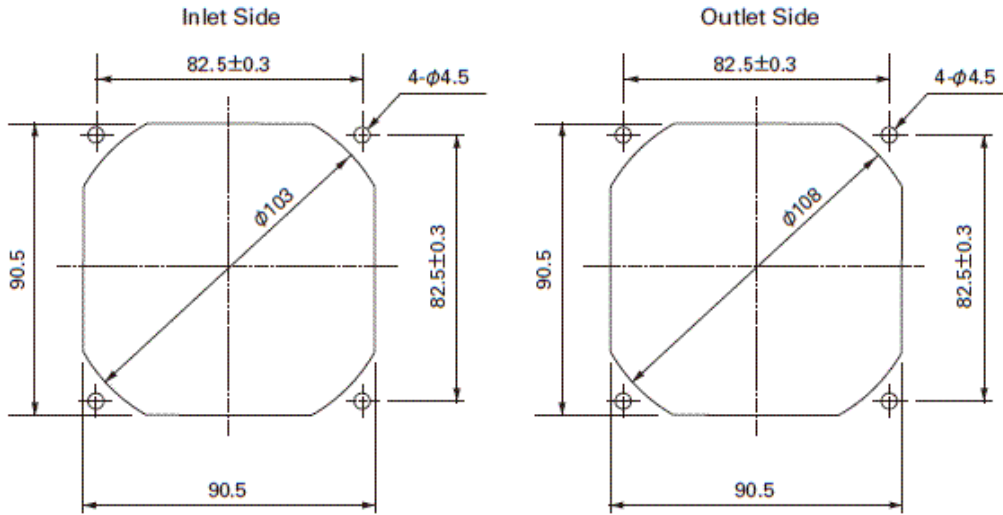

Corresponding accessories list

Finger guards
Square type

Adaptation machines-Frame size:92mm

Model No.	Surface Finishing	Adaptation machines
109-099C	Nickel-chrome plating	San Ace 92

Finger guards
Square type

Adaptation machines-Frame size:92mm

Model No.	Surface Finishing	Adaptation machines
109-099E	Nickel-chrome plating	San Ace 92
109-099H	Cation electropainting	San Ace 92

Resin finger
guards
Square type

Adaptation machines-Frame size:92mm

Model No.	Material
109-1001G	Frame:(SPS + PS alloy)Resin UL File No.E48268 94V-0

Resin filter Kits

Adaptation machines-Frame size:92mm

Model No.	PPI	Material
109-1001F13	13	Guard,cover:(SPS + PS alloy)Resin UL File No.E48268 94V-0 Filter:Polyurethane foam UL File No.E74916(S) 94HF-1

109-1001F20	20	Guard,cover:(SPS+PS alloy)Resin UL File No.E48268 94V-0 Filter:Polyurethane foam UL File No.E74916(S) 94HF-1
109-1001F30	30	Guard,cover:(SPS+PS alloy)Resin UL File No.E48268 94V-0 Filter:Polyurethane foam UL File No.E74916(S) 94HF-1
109-1001F40	40	Guard,cover:(SPS+PS alloy)Resin UL File No.E48268 94V-0 Filter:Polyurethane foam UL File No.E74916(S) 94HF-1

Resin filter Kits
Replacement
filter

 Adaptation machines-Frame size:92mm

Model No.	PPI	Material
109-1001M13	13	Polyurethane foam UL File No.E74916(S) 94HF-1
109-1001M20	20	Polyurethane foam UL File No.E74916(S) 94HF-1
109-1001M30	30	Polyurethane foam UL File No.E74916(S) 94HF-1
109-1001M40	40	Polyurethane foam UL File No.E74916(S) 94HF-1

CLOSE