

LM2695

LM2695 High Voltage (30V, 1.25A) Step Down Switching Regulator



Literature Number: SNVS413

LM2695

High Voltage (30V, 1.25A) Step Down Switching Regulator

General Description

The LM2695 Step Down Switching Regulator features all of the functions needed to implement a low cost, efficient, buck bias regulator capable of supplying 1.25A to the load. This buck regulator contains a 33V N-Channel Buck Switch, and is available in the thermally enhanced LLP-10 and TSSOP-14EP packages. The hysteretic regulation scheme requires no loop compensation, results in fast load transient response, and simplifies circuit implementation. The operating frequency remains constant with line and load variations due to the inverse relationship between the input voltage and the on-time. The current limit detection is set at 1.25A. Additional features include: VCC under-voltage lockout, thermal shutdown, gate drive under-voltage lockout, and maximum duty cycle limiter.

Features

- Integrated 33V, N-Channel buck switch
- Integrated start-up regulator
- Input Voltage Range: 8V to 30V
- No loop compensation required

- Ultra-Fast transient response
- Operating frequency remains constant with load current and input voltage
- Maximum Duty Cycle Limited During Start-Up
- Adjustable output voltage
- Valley Current Limit At 1.25A
- Precision internal reference
- Low bias current
- Highly efficient operation
- Thermal shutdown

Typical Applications

- High Efficiency Point-Of-Load (POL) Regulator
- Non-Isolated Telecommunication Buck Regulator
- Secondary High Voltage Post Regulator

Package

- LLP-10 (4 mm x 4 mm)
- TSSOP-14EP
- Exposed Thermal Pad For Improved Heat Dissipation

Basic Step Down Regulator

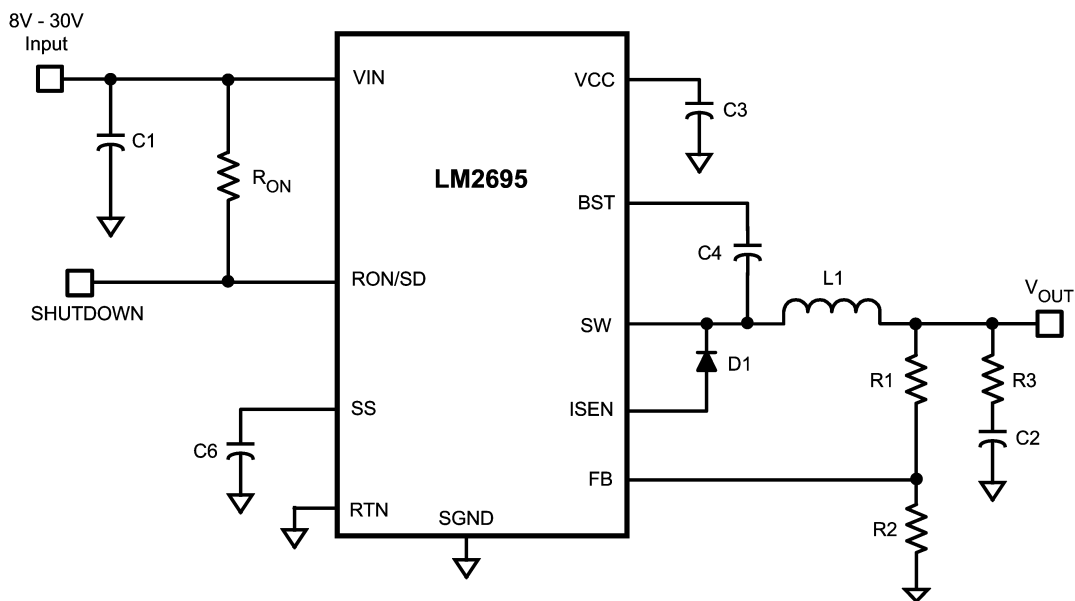

20170431

Connection Diagrams

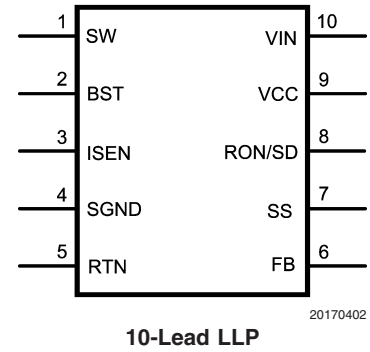
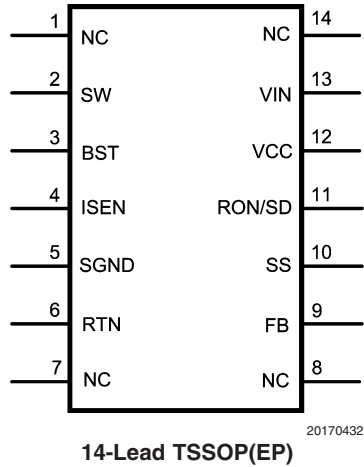

Ordering Information

Order Number	Package Type	NSC Package Drawing	Junction Temperature Range	Supplied As
LM2695SD	LLP-10 (4x4)	SDC10A	-40°C to + 125°C	1000 Units on Tape and Reel
LM2695SDX	LLP-10 (4x4)	SDC10A	-40°C to + 125°C	4500 Units on Tape and Reel
LM2695MH	TSSOP-14EP	MXA14A	-40°C to + 125°C	94 Units in Rail
LM2695MHX	TSSOP-14EP	MXA14A	-40°C to + 125°C	2500 Units on Tape and Reel

Pin Descriptions

Pin Number		Name	Description	Application Information
LLP-10	TSSOP-14			
1	2	SW	Switching Node	Internally connected to the buck switch source. Connect to the inductor, free-wheeling diode, and bootstrap capacitor.
2	3	BST	Boost pin for bootstrap capacitor	Connect a 0.022 μ F capacitor from SW to this pin. The capacitor is charged from V_{CC} via an internal diode during each off-time.
3	4	I_{SEN}	Current sense	The re-circulating current flows through the internal sense resistor, and out of this pin to the free-wheeling diode. Current limit is nominally set at 1.25A.
4	5	S_{GND}	Sense Ground	Re-circulating current flows into this pin to the current sense resistor.
5	6	RTN	Circuit Ground	Ground for all internal circuitry other than the current limit detection.
6	9	FB	Feedback input from the regulated output	Internally connected to the regulation and over-voltage comparators. The regulation level is 2.5V.
7	10	SS	Softstart	An internal 12.3 μ A current source charges an external capacitor to 2.5V, providing the softstart function.
8	11	R_{ON}/SD	On-time control and shutdown	An external resistor from V_{IN} to this pin sets the buck switch on-time. Grounding this pin shuts down the regulator.
9	12	V_{CC}	Output from the startup regulator	Nominally regulates at 7.0V. An external voltage (8V-14V) can be applied to this pin to reduce internal dissipation. An internal diode connects V_{CC} to V_{IN} .
10	13	V_{IN}	Input supply voltage	Nominal input range is 8.0V to 30V.
	1,7,8,14	NC	No connection.	No internal connection.
		EP	Exposed Pad	Exposed metal pad on the underside of the device. It is recommended to connect this pad to the PC board ground plane to aid in heat dissipation.

Absolute Maximum Ratings (Note 1)

If Military/Aerospace specified devices are required, please contact the National Semiconductor Sales Office/Distributors for availability and specifications.

VIN to RTN	33V
BST to RTN	47V
SW to RTN (Steady State)	-1.5V
ESD Rating (Note 2)	
Human Body Model	2kV
BST to VCC	33V
VIN to SW	33V
BST to SW	14V

VCC to RTN	14V
SGND to RTN	-0.3V to +0.3V
Current out of ISEN	See Text
SS to RTN	-0.3V to 4V
All Other Inputs to RTN	-0.3 to 7V
Storage Temperature Range	-65°C to +150°C
Junction Temperature	150°C

Operating Ratings (Note 1)

VIN	8.0V to 30V
Junction Temperature	-40°C to + 125°C

Electrical Characteristics Specifications with standard type are for $T_J = 25^\circ\text{C}$ only; limits in **boldface** type apply over the full Operating Junction Temperature (T_J) range. Minimum and Maximum limits are guaranteed through test, design, or statistical correlation. Typical values represent the most likely parametric norm at $T_J = 25^\circ\text{C}$, and are provided for reference purposes only. Unless otherwise stated the following conditions apply: $V_{IN} = 24\text{V}$, $R_{ON} = 200\text{k}\Omega$. See (Note 5).

Symbol	Parameter	Conditions	Min	Typ	Max	Units
Start-Up Regulator, V_{CC}						
V_{CCReg}	V_{CC} regulated output		6.6	7	7.4	V
	V_{IN} - V_{CC} dropout voltage	$I_{CC} = 0\text{ mA}$, $V_{CC} = UVLO_{VCC} + 250\text{ mV}$		1.3		V
	V_{CC} output impedance	$0\text{ mA} \leq I_{CC} \leq 5\text{ mA}$		140		Ω
	V_{CC} current limit (Note 3)	$V_{CC} = 0\text{V}$		9.7		mA
$UVLO_{VCC}$	V_{CC} under-voltage lockout threshold	V_{CC} increasing		5.7		V
	$UVLO_{VCC}$ hysteresis	V_{CC} decreasing		150		mV
	$UVLO_{VCC}$ filter delay	100 mV overdrive		3		μs
	I_{IN} operating current	Non-switching, FB = 3V		0.5	0.8	mA
	I_{IN} shutdown current	$R_{ON}/SD = 0\text{V}$		95	200	μA
Switch Characteristics						
Rds(on)	Buck Switch Rds(on)	$I_{TEST} = 200\text{ mA}$		0.33	0.7	Ω
$UVLO_{GD}$	Gate Drive UVLO	$V_{BST} - V_{SW}$ Increasing	3.0	4.4	5.5	V
	$UVLO_{GD}$ hysteresis			480		mV
Softstart Pin						
	Pull-up voltage			2.5		V
	Internal current source			12.3		μA
Current Limit						
I_{LIM}	Threshold	Current out of ISEN	1	1.25	1.5	A
	Resistance from ISEN to SGND			130		m Ω
	Response time			150		ns
On Timer						
t_{ON-1}	On-time	$V_{IN} = 10\text{V}$, $R_{ON} = 200\text{ k}\Omega$	2.1	2.8	3.6	μs
t_{ON-2}	On-time	$V_{IN} = 30\text{V}$, $R_{ON} = 200\text{ k}\Omega$		950		ns
	Shutdown threshold	Voltage at RON/SD rising	0.45	0.8	1.2	V
	Threshold hysteresis	Voltage at RON/SD falling		37		mV
Off Timer						
t_{OFF}	Minimum Off-time			250		ns
Regulation and Over-Voltage Comparators (FB Pin)						
V_{REF}	FB regulation threshold	SS pin = steady state	2.440	2.5	2.550	V
	FB over-voltage threshold			2.9		V

Electrical Characteristics Specifications with standard type are for $T_J = 25^\circ\text{C}$ only; limits in **boldface** type apply over the full Operating Junction Temperature (T_J) range. Minimum and Maximum limits are guaranteed through test, design, or statistical correlation. Typical values represent the most likely parametric norm at $T_J = 25^\circ\text{C}$, and are provided for reference purposes only. Unless otherwise stated the following conditions apply: $V_{IN} = 24\text{V}$, $R_{ON} = 200\text{k}\Omega$. See (Note 5). (Continued)

Symbol	Parameter	Conditions	Min	Typ	Max	Units
	FB bias current			1		nA
Thermal Shutdown						
T_{SD}	Thermal shutdown temperature			175		$^\circ\text{C}$
	Thermal shutdown hysteresis			20		$^\circ\text{C}$
Thermal Resistance						
θ_{JA}	Junction to Ambient 0 LFPM Air Flow	Both Packages		37		$^\circ\text{C/W}$
θ_{JC}	Junction to Case	Both Packages		6.6		$^\circ\text{C/W}$

Note 1: Absolute Maximum Ratings are limits beyond which damage to the device may occur. Operating Ratings are conditions under which operation of the device is intended to be functional. For guaranteed specifications and test conditions, see the Electrical Characteristics.

Note 2: The human body model is a 100pF capacitor discharged through a 1.5k Ω resistor into each pin.

Note 3: V_{CC} provides self bias for the internal gate drive and control circuits. Device thermal limitations limit external loading

Note 4: For detailed information on soldering plastic LLP packages, refer to the Packaging Data Book available from National Semiconductor Corporation.

Note 5: Typical specifications represent the most likely parametric norm at 25 $^\circ\text{C}$ operation.

Typical Performance Characteristics

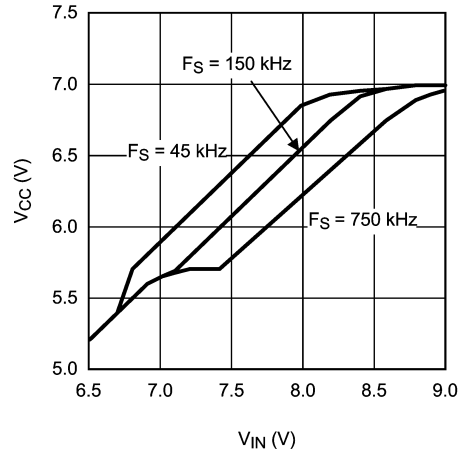

20170404

FIGURE 1. V_{CC} vs V_{IN}

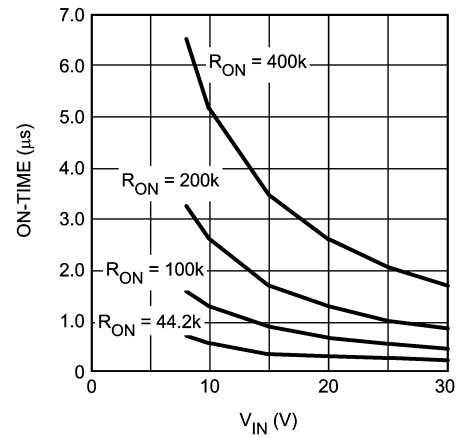

20170405

FIGURE 2. ON-Time vs V_{IN} and R_{ON}

Typical Application Circuit and Block Diagram

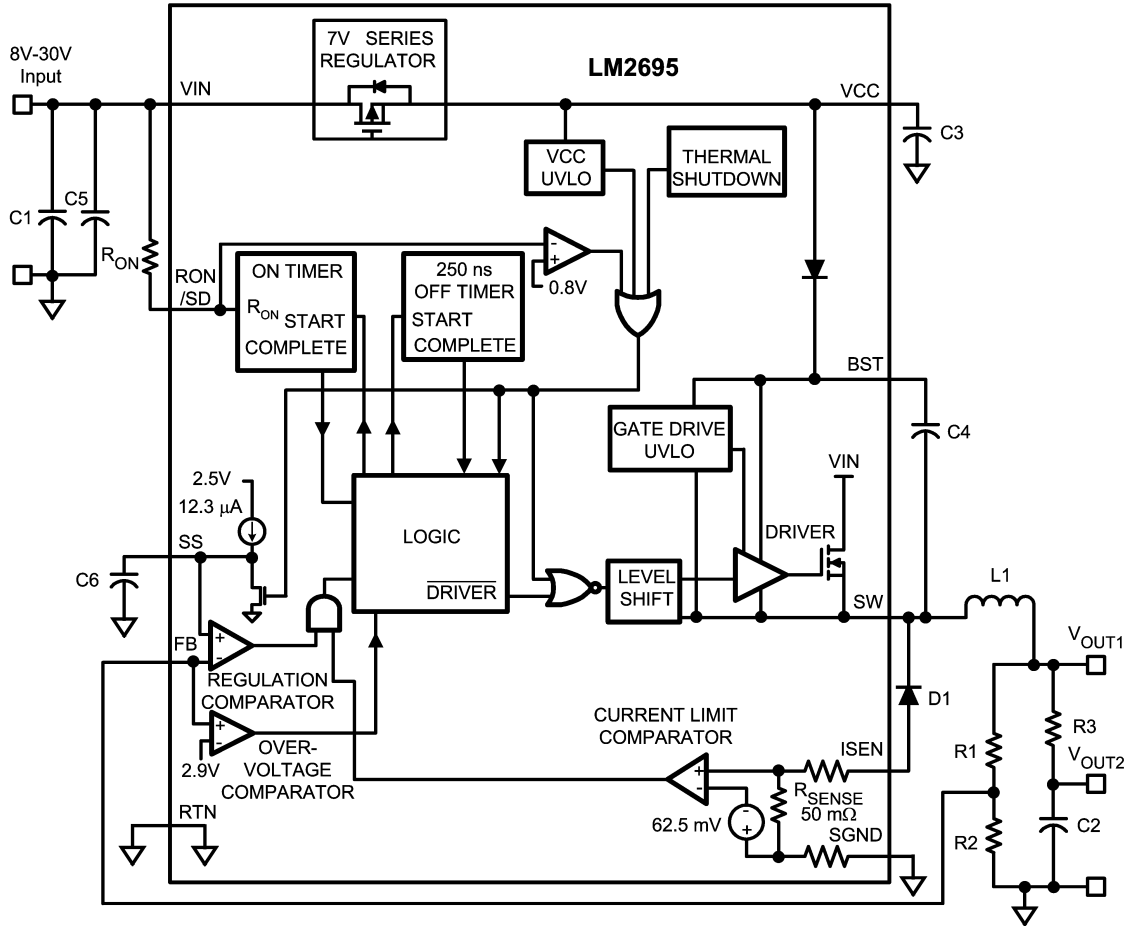

20170401

FIGURE 3.

Functional Description

The LM2695 Step Down Switching Regulator features all the functions needed to implement a low cost, efficient buck bias power converter capable of supplying 1.25A to the load. This high voltage regulator contains a 33V N-Channel buck switch, is easy to implement, and is available in the thermally enhanced LLP-10 and TSSOP-14EP packages. The regulator's operation is based on a hysteretic control scheme, and uses an on-time control which varies inversely with V_{IN} . This feature allows the operating frequency to remain relatively constant with load and input voltage variations. The hysteretic control requires no loop compensation resulting in very fast load transient response. The valley current limit detection circuit, internally set at 1.25A, holds the buck switch off until the high current level subsides. The functional block diagram is shown in *Figure 3*.

The LM2695 can be applied in numerous applications to efficiently regulate down higher voltages. Additional features include: Thermal shutdown, V_{CC} under-voltage lockout, gate drive under-voltage lockout, and maximum duty cycle limiter.

Hysteretic Control Circuit Overview

The LM2695 buck DC-DC regulator employs a control scheme based on a comparator and a one-shot on-timer, with the output voltage feedback (FB) compared to an internal reference (2.5V). If the FB voltage is below the reference the buck switch is turned on for a time period determined by the input voltage and a programming resistor (R_{ON}). Following the on-time the switch remains off for a minimum of 250 ns, and until the FB voltage falls below the reference. The buck switch then turns on for another on-time period. Typically, during start-up, or when the load current increases suddenly, the off-times are at the minimum of 250 ns. Once regulation is established, the off-times are longer.

When in regulation, the LM2695 operates in continuous conduction mode at heavy load currents and discontinuous conduction mode at light load currents. In continuous conduction mode current always flows through the inductor, never reaching zero during the off-time. In this mode the operating frequency remains relatively constant with load and line variations. The minimum load current for continuous conduction mode is one-half the inductor's ripple current amplitude. The operating frequency is approximately:

$$F_s = \frac{V_{OUT}}{1.3 \times 10^{-10} \times R_{ON}} \quad (1)$$

The buck switch duty cycle is equal to:

$$DC = \frac{t_{ON}}{t_{ON} + t_{OFF}} = \frac{V_{OUT}}{V_{IN}} \quad (2)$$

In discontinuous conduction mode current through the inductor ramps up from zero to a peak during the on-time, then ramps back to zero before the end of the off-time. The next on-time period starts when the voltage at FB falls below the reference - until then the inductor current remains zero, and the load current is supplied by the output capacitor (C2). In this mode the operating frequency is lower than in continuous conduction mode, and varies with load current. Conversion efficiency is maintained at light loads since the switching losses reduce with the reduction in load and frequency. The approximate discontinuous operating frequency can be calculated as follows:

$$F_s = \frac{V_{OUT}^2 \times L1 \times 1.18 \times 10^{20}}{R_L \times (R_{ON})^2} \quad (3)$$

where R_L = the load resistance.

The output voltage is set by two external resistors (R1, R2). The regulated output voltage is calculated as follows:

$$V_{OUT} = 2.5 \times (R1 + R2) / R2$$

Output voltage regulation is based on ripple voltage at the feedback input, requiring a minimum amount of ESR for the output capacitor C2. The LM2695 requires a minimum of 25 mV of ripple voltage at the FB pin. In cases where the capacitor's ESR is insufficient additional series resistance may be required (R3 in *Figure 3*).

For applications where lower output voltage ripple is required the output can be taken directly from a low ESR output capacitor as shown in *Figure 4*. However, R3 slightly degrades the load regulation.

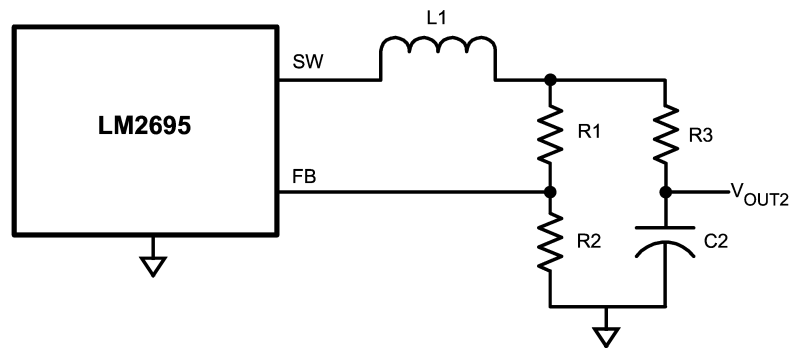

20170410

FIGURE 4. Low Ripple Output Configuration

Start-Up Regulator, V_{CC}

The start-up regulator is integral to the LM2695. The input pin (V_{IN}) can be connected directly to line voltage up to 30V, with transient capability to 33V. The V_{CC} output regulates at 7.0V, and is current limited at 9.7 mA. Upon power up, the regulator sources current into the external capacitor at VCC (C3). When the voltage on the VCC pin reaches the under-voltage lockout threshold of 5.7V, the buck switch is enabled and the Softstart pin is released to allow the Softstart capacitor (C6) to charge up.

The minimum input voltage is determined by the regulator's dropout voltage, the V_{CC} UVLO falling threshold ($\approx 5.5V$),

and the frequency. When V_{CC} falls below the falling threshold the V_{CC} UVLO activates to shut off the output. If V_{CC} is externally loaded, the minimum input voltage increases since the output impedance at V_{CC} is $\approx 140\Omega$.

To reduce power dissipation in the start-up regulator, an auxiliary voltage can be diode connected to the V_{CC} pin. Setting the auxiliary voltage to between 8V and 14V shuts off the internal regulator, reducing internal power dissipation. The sum of the auxiliary voltage and the input voltage ($V_{CC} + V_{IN}$) cannot exceed 47V. Internally, a diode connects VCC to V_{IN} . See *Figure 5*.

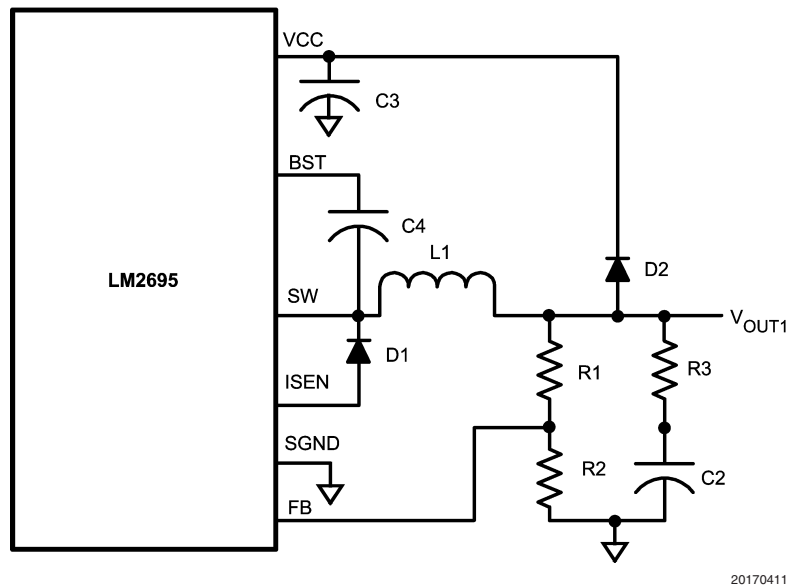

FIGURE 5. Self Biased Configuration

Regulation Comparator

The feedback voltage at FB is compared to the voltage at the Softstart pin (2.5V). In normal operation (the output voltage is regulated), an on-time period is initiated when the voltage at FB falls below 2.5V. The buck switch stays on for the programmed on-time, causing the FB voltage to rise above 2.5V. After the on-time period, the buck switch stays off until the FB voltage falls below 2.5V. Input bias current at the FB pin is less than 100 nA over temperature.

Over-Voltage Comparator

The voltage at FB is compared to an internal 2.9V reference. If the voltage at FB rises above 2.9V the on-time pulse is immediately terminated. This condition can occur if the input voltage or the output load changes suddenly, or if the inductor (L1) saturates. The buck switch remains off until the voltage at FB falls below 2.5V.

ON-Time Timer, and Shutdown

The on-time for the LM2695 is determined by the R_{ON} resistor and the input voltage (V_{IN}), and is calculated from:

$$t_{ON} = \frac{1.3 \times 10^{-10} \times R_{ON}}{V_{IN}} \quad (4)$$

See *Figure 2*. The inverse relationship with V_{IN} results in a nearly constant frequency as V_{IN} is varied. To set a specific continuous conduction mode switching frequency (F_S), the R_{ON} resistor is determined from the following:

$$R_{ON} = \frac{V_{OUT}}{F_S \times 1.3 \times 10^{-10}} \quad (5)$$

In high frequency applications the minimum value for t_{ON} is limited by the maximum duty cycle required for regulation and the minimum off-time of (250 ns, $\pm 15\%$). The minimum off-time limits the maximum duty cycle achievable with a low voltage at V_{IN} . The minimum allowed on-time to regulate the desired V_{OUT} at the minimum V_{IN} is determined from the following:

$$t_{ON(min)} = \frac{V_{OUT} \times 288 \text{ ns}}{(V_{IN(min)} - V_{OUT})} \quad (6)$$

ON-Time Timer, and Shutdown

(Continued)

The LM2695 can be remotely shut down by taking the RON/SD pin below 0.8V. See *Figure 6*. In this mode the SS pin is internally grounded, the on-timer is disabled, and bias currents are reduced. Releasing the RON/SD pin allows normal operation to resume. The voltage at the RON/SD pin is between 1.5V and 3.0V, depending on V_{IN} and the R_{ON} resistor.

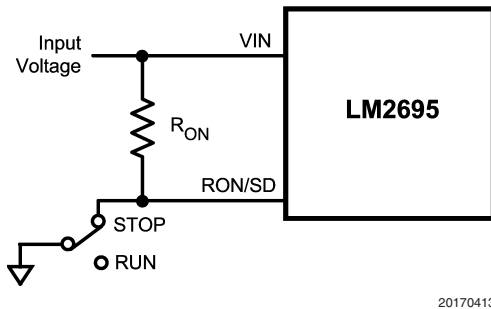

FIGURE 6. Shutdown Implementation

Current Limit

Current limit detection occurs during the off-time by monitoring the recirculating current through the free-wheeling diode

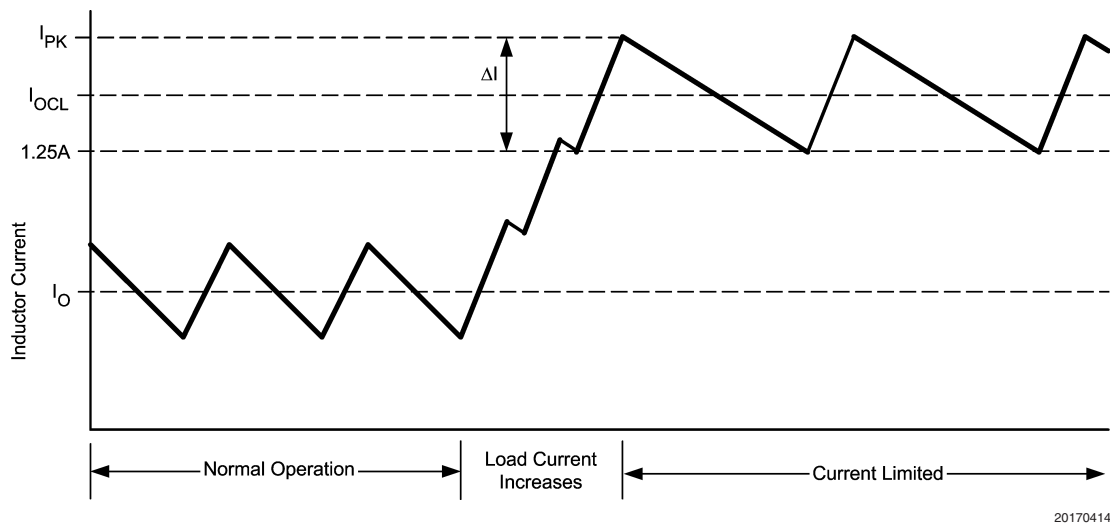

FIGURE 7. Inductor Current - Current Limit Operation

The current limit threshold can be increased by connecting an external resistor between SGND and ISEN. The external resistor will typically be less than 1Ω. The peak current out of SW and ISEN must not exceed 2A. The average current out of SW must be less than 1.5A.

N - Channel Buck Switch and Driver

The LM2695 integrates an N-Channel buck switch and associated floating high voltage gate driver. The peak current allowed through the buck switch is 2A, and the maximum

(D1). Referring to *Figure 3*, when the buck switch is turned off the inductor current flows through the load, into SGND, through the sense resistor, out of ISEN and through D1. If that current exceeds 1.25A the current limit comparator output switches to delay the start of the next on-time period if the voltage at FB is below 2.5V. The next on-time starts when the current out of ISEN is below 1.25A and the voltage at FB is below 2.5V. If the overload condition persists causing the inductor current to exceed 1.25A during each on-time, that is detected at the beginning of each off-time. The operating frequency is lower due to longer-than-normal off-times.

Figure 7 illustrates the inductor current waveform. During normal operation the load current is I_O , the average of the ripple waveform. When the load resistance decreases the current ratchets up until the lower peak reaches 1.25A. During the Current Limited portion of *Figure 7*, the current ramps down to 1.25A during each off-time, initiating the next on-time (assuming the voltage at FB is $<2.5V$). During each on-time the current ramps up an amount equal to:

$$\Delta I = (V_{IN} - V_{OUT}) \times t_{ON} / L1$$

During this time the LM2695 is in a constant current mode, with an average load current (I_{OCL}) equal to $1.25A + \Delta I/2$.

Softstart

The softstart feature allows the converter to gradually reach a steady state operating point, thereby reducing start-up stresses and current surges. Upon turn-on, after V_{CC} reaches the under-voltage threshold, an internal 12.3 μA current source charges up the external capacitor at the SS pin to 2.5V. The ramping voltage at SS (and the non-inverting input of the regulation comparator) ramps up the output voltage in a controlled manner.

An internal switch grounds the SS pin if V_{CC} is below the under-voltage lockout threshold, if a thermal shutdown occurs, or if the RON/SD pin is grounded.

Thermal Shutdown

The LM2695 should be operated so the junction temperature does not exceed 125°C. If the junction temperature increases, an internal Thermal Shutdown circuit, which activates (typically) at 175°C, takes the controller to a low power reset state by disabling the buck switch and the on-timer, and grounding the Softstart pin. This feature helps prevent catastrophic failures from accidental device overheating. When the junction temperature reduces below 155°C (typical hysteresis = 20°C), the Softstart pin is released and normal operation resumes.

Applications Information

EXTERNAL COMPONENTS

The following guidelines can be used to select the external components.

R1 and R2: The ratio of these resistors is calculated from:

$$R1/R2 = (V_{OUT}/2.5V) - 1$$

R1 and R2 should be chosen from standard value resistors in the range of 1.0 k Ω - 10 k Ω which satisfy the above ratio.

R_{ON}: The minimum value for R_{ON} is calculated from:

$$R_{ON} \geq \frac{200 \text{ ns} \times V_{IN(MAX)}}{1.3 \times 10^{-10}}$$

Equation 1 can be used to select R_{ON} if a specific frequency is desired as long as the above limitation is met.

L1: The main parameter affected by the inductor is the output current ripple amplitude (I_{OR}). The limits for I_{OR} must be determined at both the minimum and maximum nominal load currents.

a) If the maximum load current is less than the current limit threshold (1.25A), the minimum load current is used to determine the maximum allowable ripple. To maintain continuous conduction mode the lower peak should not reach 0 mA. For this case, the maximum ripple current is:

$$I_{OR(MAX1)} = 2 \times I_{O(min)} \quad (7)$$

The ripple calculated in Equation 7 is then used in the following equation:

$$L1 = \frac{V_{OUT} \times (V_{IN} - V_{OUT})}{I_{OR} \times F_S \times V_{IN}} \quad (8)$$

where V_{IN} is the maximum input voltage and F_S is determined from equation 1. This provides a minimum value for L1. The next larger standard value should be used, and L1 should be rated for the I_{PK} current level.

b) If the maximum load current is greater than the current limit threshold (1.25A), the LM2695 ensures the lower peak reaches 1.25A each cycle, requiring that I_{OR} be at least twice the difference. The upper peak, however, must not exceed 2A. For this case, the ripple limits are:

$$I_{OR(MAX2)} = 2 \times (2A - I_{O(max)}) \quad (9)$$

and

$$I_{OR(MIN1)} = 2 \times (I_{O(max)} - 1.25A) \quad (10)$$

The lesser of Equations 9 and 10 is then used in Equation 8. If $I_{OR(MAX2)}$ is used, the maximum V_{IN} is used in Equation 8. The next larger value should then be used for L1. If $I_{OR(MIN1)}$ is used, the minimum V_{IN} is used in Equation 8. The next smaller value should then be used for L1. L1 must be rated for the peak value of the current waveform (I_{PK} in Figure 7).

C3: The capacitor at the V_{CC} output provides not only noise filtering and stability, but also prevents false triggering of the V_{CC} UVLO at the buck switch on/off transitions. For this reason, C3 should be no smaller than 0.1 μF , and should be a good quality, low ESR, ceramic capacitor.

C2, and R3: Since the LM2695 requires a minimum of 25 mV_{p-p} of ripple at the FB pin for proper operation, the required ripple at V_{OUT1} is increased by R1 and R2. This necessary ripple is created by the inductor ripple current acting on C2's ESR + R3. The minimum ripple current is calculated using equation 8, rearranged to solve for I_{OR} at minimum V_{IN} . The minimum ESR for C2 is then equal to:

$$ESR_{(min)} = \frac{25 \text{ mV} \times (R1 + R2)}{R2 \times I_{OR(min)}} \quad (11)$$

If the capacitor used for C2 does not have sufficient ESR, R3 is added in series as shown in Figure 3. Generally R3 is less than 1 Ω . C2 should generally be no smaller than 3.3 μF , although that is dependent on the frequency and the allowable ripple amplitude at V_{OUT1} . Experimentation is usually necessary to determine the minimum value for C2, as the nature of the load may require a larger value. A load which creates significant transients requires a larger value for C2 than a non-varying load.

D1: The important parameters are reverse recovery time and forward voltage. The reverse recovery time determines how long the reverse current surge lasts each time the buck switch is turned on. The forward voltage drop is significant in the event the output is short-circuited as it is mainly this diode's voltage (plus the voltage across the current limit sense resistor) which forces the inductor current to decrease during the off-time. For this reason, a higher voltage is better, although that affects efficiency. A reverse recovery time of ≈ 30 ns, and a forward voltage drop of $\approx 0.75\text{V}$ are preferred. The reverse leakage specification is important as that can significantly affect efficiency. D1's reverse voltage rating must be at least as great as the maximum V_{IN} , and its current rating must equal or exceed I_{PK} Figure 7.

C1 and C5: C1's purpose is to supply most of the switch current during the on-time, and limit the voltage ripple at V_{IN} , on the assumption that the voltage source feeding V_{IN} has an output impedance greater than zero. If the source's dynamic impedance is high (effectively a current source), it supplies the average input current, but not the ripple current.

Applications Information (Continued)

At maximum load current, when the buck switch turns on, the current into VIN suddenly increases to the lower peak of the inductor's ripple current, ramps up to the peak value, then drop to zero at turn-off. The average current during the on-time is the load current. For a worst case calculation, C1 must supply this average load current during the maximum on-time. C1 is calculated from:

$$C1 = \frac{I_O \times t_{ON}}{\Delta V}$$

where I_O is the load current, t_{ON} is the maximum on-time, and ΔV is the allowable ripple voltage at V_{IN} . C5's purpose is to help avoid transients and ringing due to long lead inductance at V_{IN} . A low ESR, 0.1 μ F ceramic chip capacitor is recommended, located close to the LM2695 .

C4: The recommended value for C4 is 0.022 μ F. A high quality ceramic capacitor with low ESR is recommended as C4 supplies a surge current to charge the buck switch gate at turn-on. A low ESR also helps ensure a complete recharge during each off-time.

C6: The capacitor at the SS pin determines the softstart time, i.e. the time for the reference voltage at the regulation comparator, and the output voltage, to reach their final value. The time is determined from the following:

$$t_{SS} = \frac{C6 \times 2.5V}{12.3 \mu A}$$

PC BOARD LAYOUT

The LM2695 regulation, over-voltage, and current limit comparators are very fast, and respond to short duration noise pulses. Layout considerations are therefore critical for optimum performance. The layout must be as neat and compact as possible, and all of the components must be as close as possible to their associated pins. The current loop formed by D1, L1, C2 and the SGND and ISEN pins should be as small as possible. The ground connection from C2 to C1 should be as short and direct as possible.

If it is expected that the internal dissipation of the LM2695 will produce excessive junction temperatures during normal operation, good use of the PC board's ground plane can help considerably to dissipate heat. The exposed pad on the bottom of the IC package can be soldered to a ground plane, and that plane should extend out from beneath the IC, and be connected to ground plane on the board's other side with several vias, to help dissipate the heat. The exposed pad is internally connected to the IC substrate. Additionally the use of wide PC board traces, where possible, can help conduct heat away from the IC. Judicious positioning of the PC board within the end product, along with the use of any available air flow (forced or natural convection) can help reduce the junction temperatures.

Physical Dimensions inches (millimeters) unless otherwise noted

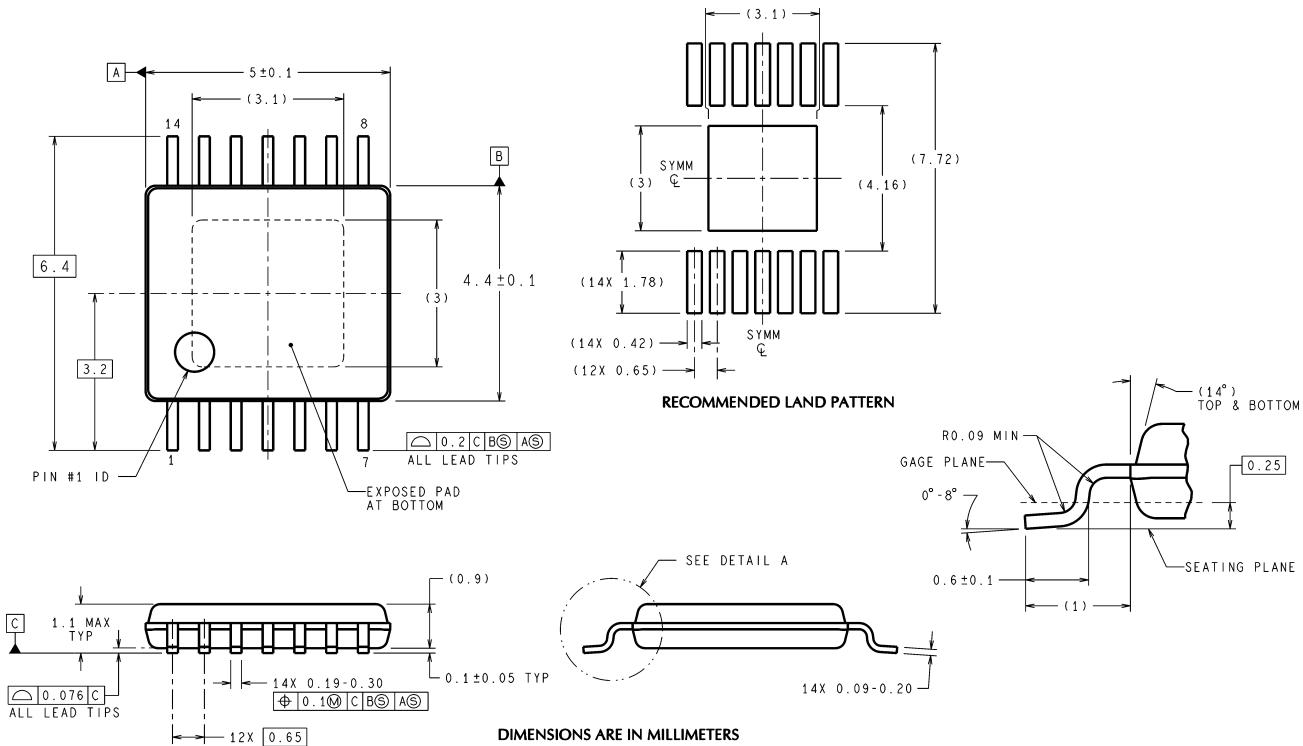

14-Lead TSSOP-14EP Package
NS Package Number MXA14A

MXA14A (Rev A)

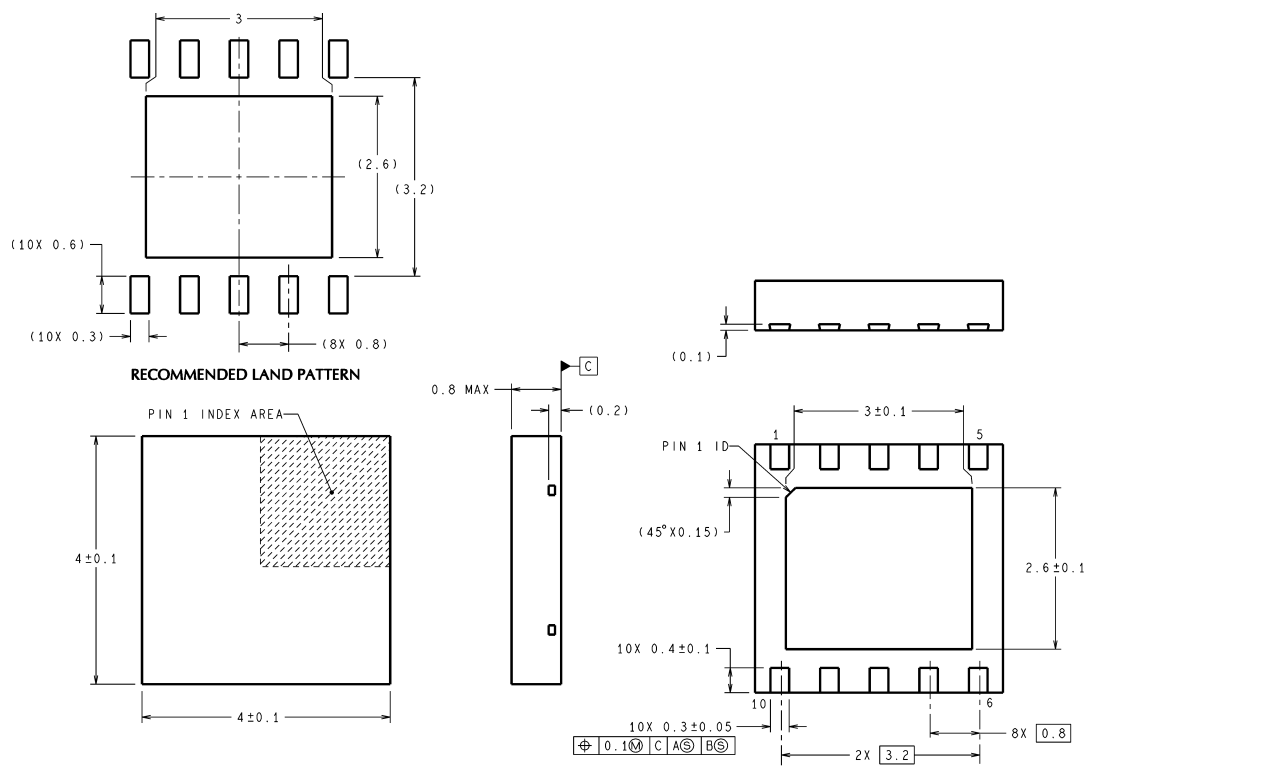

10-Lead LLP Package
NS Package Number SDC10A

SDC10A (Rev A)

Notes

National does not assume any responsibility for use of any circuitry described, no circuit patent licenses are implied and National reserves the right at any time without notice to change said circuitry and specifications.

For the most current product information visit us at www.national.com.

LIFE SUPPORT POLICY

NATIONAL'S PRODUCTS ARE NOT AUTHORIZED FOR USE AS CRITICAL COMPONENTS IN LIFE SUPPORT DEVICES OR SYSTEMS WITHOUT THE EXPRESS WRITTEN APPROVAL OF THE PRESIDENT AND GENERAL COUNSEL OF NATIONAL SEMICONDUCTOR CORPORATION. As used herein:

1. Life support devices or systems are devices or systems which, (a) are intended for surgical implant into the body, or (b) support or sustain life, and whose failure to perform when properly used in accordance with instructions for use provided in the labeling, can be reasonably expected to result in a significant injury to the user.
2. A critical component is any component of a life support device or system whose failure to perform can be reasonably expected to cause the failure of the life support device or system, or to affect its safety or effectiveness.

BANNED SUBSTANCE COMPLIANCE

National Semiconductor manufactures products and uses packing materials that meet the provisions of the Customer Products Stewardship Specification (CSP-9-111C2) and the Banned Substances and Materials of Interest Specification (CSP-9-111S2) and contain no "Banned Substances" as defined in CSP-9-111S2.

Leadfree products are RoHS compliant.



National Semiconductor
Americas Customer
Support Center
Email: new.feedback@nsc.com
Tel: 1-800-272-9959

www.national.com

National Semiconductor
Europe Customer Support Center
Fax: +49 (0) 180-530 85 86
Email: europe.support@nsc.com
Deutsch Tel: +49 (0) 69 9508 6208
English Tel: +44 (0) 870 24 0 2171
Français Tel: +33 (0) 1 41 91 8790

National Semiconductor
Asia Pacific Customer
Support Center
Email: ap.support@nsc.com

National Semiconductor
Japan Customer Support Center
Fax: 81-3-5639-7507
Email: jpn.feedback@nsc.com
Tel: 81-3-5639-7560

IMPORTANT NOTICE

Texas Instruments Incorporated and its subsidiaries (TI) reserve the right to make corrections, modifications, enhancements, improvements, and other changes to its products and services at any time and to discontinue any product or service without notice. Customers should obtain the latest relevant information before placing orders and should verify that such information is current and complete. All products are sold subject to TI's terms and conditions of sale supplied at the time of order acknowledgment.

TI warrants performance of its hardware products to the specifications applicable at the time of sale in accordance with TI's standard warranty. Testing and other quality control techniques are used to the extent TI deems necessary to support this warranty. Except where mandated by government requirements, testing of all parameters of each product is not necessarily performed.

TI assumes no liability for applications assistance or customer product design. Customers are responsible for their products and applications using TI components. To minimize the risks associated with customer products and applications, customers should provide adequate design and operating safeguards.

TI does not warrant or represent that any license, either express or implied, is granted under any TI patent right, copyright, mask work right, or other TI intellectual property right relating to any combination, machine, or process in which TI products or services are used. Information published by TI regarding third-party products or services does not constitute a license from TI to use such products or services or a warranty or endorsement thereof. Use of such information may require a license from a third party under the patents or other intellectual property of the third party, or a license from TI under the patents or other intellectual property of TI.

Reproduction of TI information in TI data books or data sheets is permissible only if reproduction is without alteration and is accompanied by all associated warranties, conditions, limitations, and notices. Reproduction of this information with alteration is an unfair and deceptive business practice. TI is not responsible or liable for such altered documentation. Information of third parties may be subject to additional restrictions.

Resale of TI products or services with statements different from or beyond the parameters stated by TI for that product or service voids all express and any implied warranties for the associated TI product or service and is an unfair and deceptive business practice. TI is not responsible or liable for any such statements.

TI products are not authorized for use in safety-critical applications (such as life support) where a failure of the TI product would reasonably be expected to cause severe personal injury or death, unless officers of the parties have executed an agreement specifically governing such use. Buyers represent that they have all necessary expertise in the safety and regulatory ramifications of their applications, and acknowledge and agree that they are solely responsible for all legal, regulatory and safety-related requirements concerning their products and any use of TI products in such safety-critical applications, notwithstanding any applications-related information or support that may be provided by TI. Further, Buyers must fully indemnify TI and its representatives against any damages arising out of the use of TI products in such safety-critical applications.

TI products are neither designed nor intended for use in military/aerospace applications or environments unless the TI products are specifically designated by TI as military-grade or "enhanced plastic." Only products designated by TI as military-grade meet military specifications. Buyers acknowledge and agree that any such use of TI products which TI has not designated as military-grade is solely at the Buyer's risk, and that they are solely responsible for compliance with all legal and regulatory requirements in connection with such use.

TI products are neither designed nor intended for use in automotive applications or environments unless the specific TI products are designated by TI as compliant with ISO/TS 16949 requirements. Buyers acknowledge and agree that, if they use any non-designated products in automotive applications, TI will not be responsible for any failure to meet such requirements.

Following are URLs where you can obtain information on other Texas Instruments products and application solutions:

Products

Audio	www.ti.com/audio
Amplifiers	amplifier.ti.com
Data Converters	dataconverter.ti.com
DLP® Products	www.dlp.com
DSP	dsp.ti.com
Clocks and Timers	www.ti.com/clocks
Interface	interface.ti.com
Logic	logic.ti.com
Power Mgmt	power.ti.com
Microcontrollers	microcontroller.ti.com
RFID	www.ti-rfid.com
OMAP Mobile Processors	www.ti.com/omap
Wireless Connectivity	www.ti.com/wirelessconnectivity

Applications

Communications and Telecom	www.ti.com/communications
Computers and Peripherals	www.ti.com/computers
Consumer Electronics	www.ti.com/consumer-apps
Energy and Lighting	www.ti.com/energy
Industrial	www.ti.com/industrial
Medical	www.ti.com/medical
Security	www.ti.com/security
Space, Avionics and Defense	www.ti.com/space-avionics-defense
Transportation and Automotive	www.ti.com/automotive
Video and Imaging	www.ti.com/video

TI E2E Community Home Page

e2e.ti.com

Mailing Address: Texas Instruments, Post Office Box 655303, Dallas, Texas 75265
Copyright © 2011, Texas Instruments Incorporated