

Static Control Wrist Strap

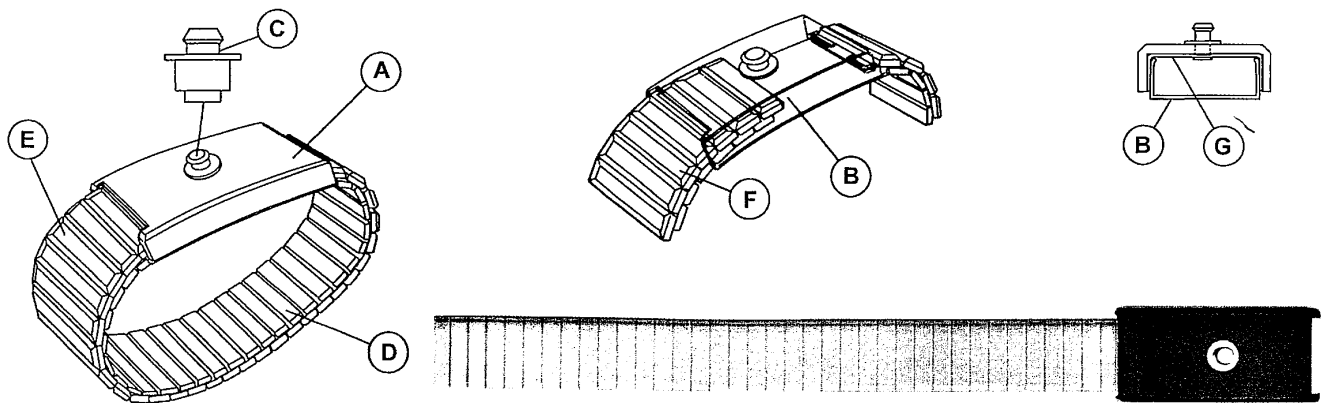

Features:

- Metal Expansion
- 4mm Stud



Description:

- A. Fixed black glass-filled nylon cap with slotted opening to allow size adjustment, no printing.
- B. 300 Series Stainless Steel Backplate forms channel to hold up to 10 links of band allowing size adjustment.
- C. 4mm snap stud machined from 300 series stainless steel. Fits to 4mm spring loaded medical type socket. Coil Cord disengages from snap with 1 to 5 lbs. of perpendicular force, fulfilling ESD-S1 paragraph 4.1.6 breakaway force requirement.
- D. Metal expansion band. Inside links are constructed of 300 Series Stainless Steel. Made in America.
- E. Chrome plate painted surface - blue
- F. Size is adjustable by sliding 1 to 10 links of the band into the backplate "C" channel. Minimum circumference = 5.75". Maximum circumference = 13".
- G. 300 Series Stainless Steel clip for electrical contact between snap stud and backplate.

Meet or exceeds requirements of ANSI ESD-S20.20 and EOS/ESD-S1-1987

Part Number Table

Description	Part Number
Static Control Wrist Strap	MC35011

Important Notice : This data sheet and its contents (the "Information") belong to the members of the Premier Farnell group of companies (the "Group") or are licensed to it. No licence is granted for the use of it other than for information purposes in connection with the products to which it relates. No licence of any intellectual property rights is granted. The Information is subject to change without notice and replaces all data sheets previously supplied. The Information supplied is believed to be accurate but the Group assumes no responsibility for its accuracy or completeness, any error in or omission from it or for any use made of it. Users of this data sheet should check for themselves the Information and the suitability of the products for their purpose and not make any assumptions based on information included or omitted. Liability for loss or damage resulting from any reliance on the Information or use of it (including liability resulting from negligence or where the Group was aware of the possibility of such loss or damage arising) is excluded. This will not operate to limit or restrict the Group's liability for death or personal injury resulting from its negligence. Multicomp is the registered trademark of the Group. © Premier Farnell plc 2012.

www.element14.com
www.farnell.com
www.newark.com

