

Ferrite ring cores (toroids)

TN10/6/4

RING CORES (TOROIDS)

Effective core parameters

SYMBOL	PARAMETER	VALUE	UNIT
$\Sigma(I/A)$	core factor (C1)	3.07	mm ⁻¹
V_e	effective volume	188	mm ³
l_e	effective length	24.1	mm
A_e	effective area	7.8	mm ²
m	mass of core	≈0.95	g

Coating

The cores are coated with polyamide 11 (PA11), flame retardant in accordance with "UL 94V-2"; UL file number E 45228 (M).

Isolation voltage

DC isolation voltage: 1000 V.
 Contacts are applied on the edge of the ring core, which is also the critical point for the winding operation.

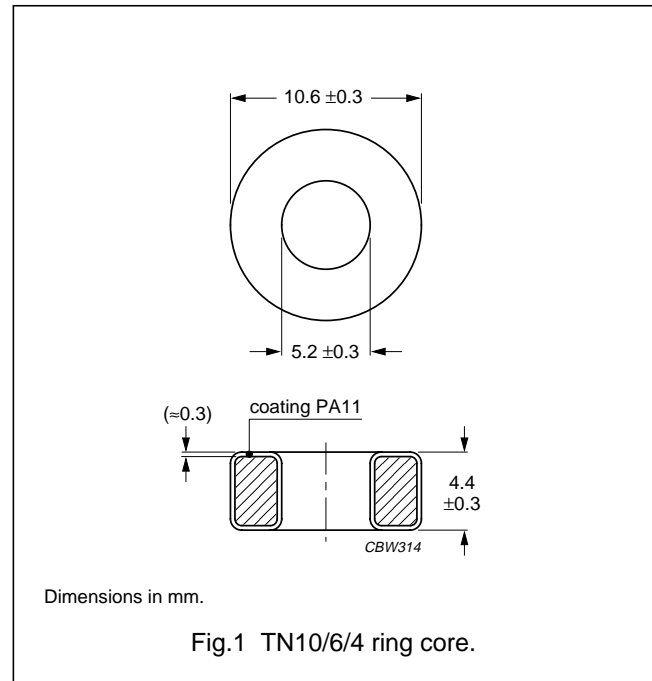

Ring core data

GRADE	A_L (nH)	μ_i	COLOUR CODE	TYPE NUMBER
4C65 ^{sup}	52 ±25%	≈125	violet	TN10/6/4-4C65
4A11	286 ±25%	≈700	pink	TN10/6/4-4A11
3F3 ^{sup}	740 ±25%	≈1800	blue	TN10/6/4-3F3
3C90 ^{sup}	940 ±25%	≈2300	ultramarine	TN10/6/4-3C90
3C11	1750 ±25%	≈4300	white	TN10/6/4-3C11
3E25 ^{sup}	2250 ±30%	≈5500	orange	TN10/6/4-3E25
3E5	3470 ±30%	≈8500	yellow/white	TL10/6/4-3E5 ⁽¹⁾
3E6 ^{des}	4085 ±30%	≈10000	purple/white	TL10/6/4-3E6 ⁽¹⁾

Note

- Ring cores in 3E5 and 3E6 are lacquered (polyurethane) and have different dimensions:
 Outside diameter = 10.25 ±0.4 mm; inside diameter = 5.75 ±0.3 mm; height = 4.25 ±0.3 mm; flame retardant in accordance with "UL 94V-2"; UL file number E 192048.

Properties of cores under power conditions

GRADE	B (mT) at	CORE LOSS (W) at		
	H = 250 A/m; f = 25 kHz; T = 100 °C	f = 25 kHz; Ḃ = 200 mT; T = 100 °C	f = 100 kHz; Ḃ = 100 mT; T = 100 °C	f = 400 kHz; Ḃ = 50 mT; T = 100 °C
3C90	≥320	≤0.021	≤0.021	–
3F3	≥320	–	≤0.03	≤0.04