

XY2 Cable Pull General Information

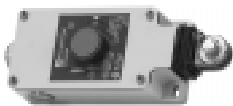

XY2CE1A196



XY2CH13150

These devices are typically used for conveyor systems, transfer machines, presses, woodworking equipment, painting lines, test laboratories, etc. The cable is stretched between the switch and an anchor. The cable pull emergency stop is usually located close to a machine or installation containing moving parts that may present a hazard while in operation. The operator must be able to easily pull the cable from anywhere within the critical zone. **To qualify as an emergency stop the cable pull switch must be of direct (positive) opening contact type and actuated if the cable is pulled or broken (taut cable principle). It must also latch in the open position until the operator will manually reset it. The operator (cable) color must be red.**

Momentary action switches don't have the latching feature and don't require direct (positive) opening contacts.

XY2CE and XY2CH cable pull switches meet all the requirements of the harmonized European standard EN418, relating to Emergency Stop devices.

The use of an end spring is strongly advised in the recommendations of the European draft standard EN616, when using cable pull devices on continuous duty mechanical handling equipment and systems.

Features include:

- 3 cable entries 1/2" NPT
- Positive latching (no teasing)
- Direct opening N.C. contacts meets the IEC and EN requirements for positive opening contacts per IEC 947-5-1, EN 60947-5-1; and NEMA ICS-5, part 6 (direct opening action).
- Slow-make slow-break for emergency stop
- Snap action contacts for momentary switch
- Works properly even if spring is broken
- Lock-out option
- Doesn't reset if out of adjustment
- Manual tripping force adjustment
- Traction force indicator
- Adjustment indicator
- Corrosion proof models available
- UL Listed and CSA Certified
- XY2CH for applications up to 50 feet (15m)
- XY2CH has two viewing windows to aid in setting and adjusting the switch
- XY2CE for applications up to 165 feet (50m)

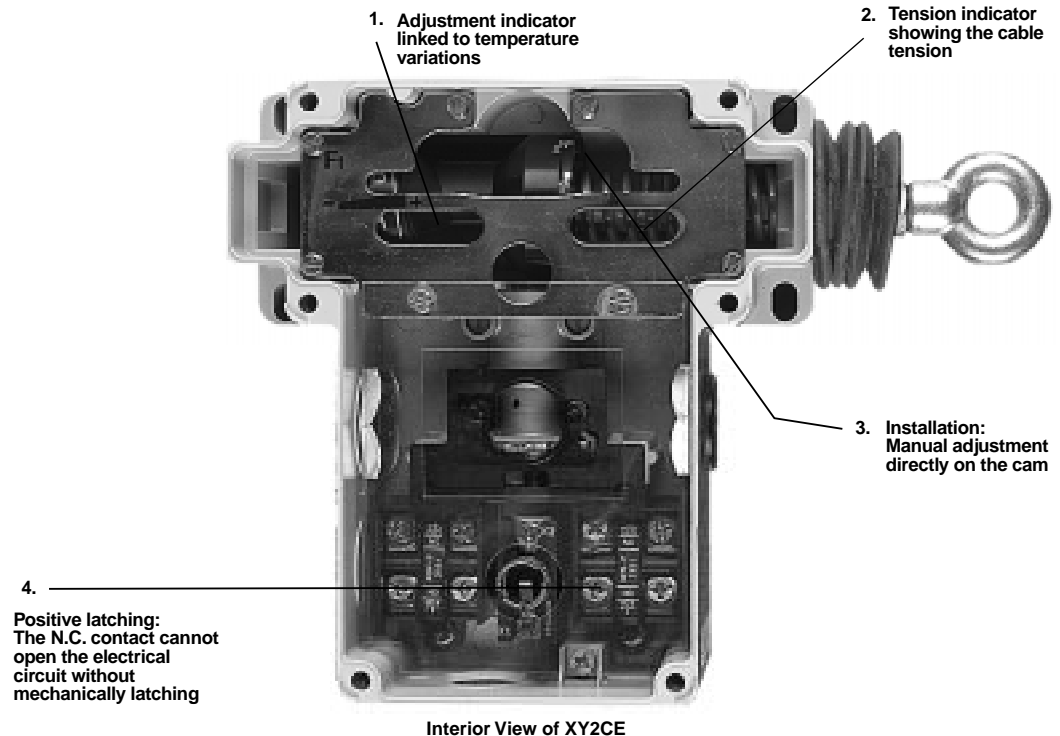

XY2 Cable Pull General Specifications

General Characteristics

Conformity to standards Approvals	ANSI A 17.1, IEC 947-5-1, EN 60204-1, NFC 79-130, NFC 63144, VDE 0660-207, XY2CE and XY2CH: UL Listed and CSA Approved.
Ambient temperature	For operation from -13 °F to +158 °F (-25 °C to +70 °C) for standard devices; -40 °F to 158 °F (-40 °C to +70 °C) for TK (corrosion proof) versions. For storage from -40 °F to +158 °F (-40 °C to +70 °C) for all devices. The minimum temperatures listed are based on the absence of freezing moisture or water. ■
Vibration resistance	XY2CE: 10G, (F=10 to 300 Hz), XY2CH: 10G, (F=10 to 150 Hz), conforming to IEC 68-2-6
Shock resistance	50G, duration 11 ms, conforming to IEC 68-2-27
Electric shock protection	UL 508, 19-1, Class I conforming to IEC 536 and NF C 20-030.
Enclosure rating	NEMA Type 1,4,12, IP 65 conforming to IEC 529, IP 657 conforming to NF C 20-010 (IP 667 with booting push button).
Mechanical life	10,000 operations for emergency stop; 100,000 operations for normal stop
Cable entry	3 x 1/2" NPT
Operating position	All positions.
Length of protected area	XY2CE: maximum 165 ft. (50m), XY2CH: maximum 50 ft. (15m)

■ The minimum temperatures listed are based on the absence of freezing moisture or water. Care should be taken to avoid sub-freezing temperatures where dripping or splashing water is present and to avoid bringing a cold device into a humid atmosphere and then back into sub-freezing temperatures. The water or moisture may freeze around internal or external components and prevent it from performing as intended.

Electrical Characteristics

Rated thermal current	10A conforming to UL 508, CSA C 22-2 N° 14, IEC 947-5-1, NFC 63140, VDE 0660-200.
Rated insulation voltage	300 Vac and Vdc conforming to UL 508, CSA 22-2 N° 14, 500 V conforming to IEC 158-1, NFC 20-040; 300 V conforming to VDE 0660-207.
Contact operation	SPDT Slow-make slow-break, direct▲ opening operation contacts for emergency stops. SPDT Snap action for normal stops without mechanical latching.
Resistance between terminals (Max.)	≤ 25 mΩ
Terminal referencing	13-14 normally open, 21-22 normally closed (conforming to CENELEC EN 50 013).
Voltage range	24 to 380 V
Wiring terminals	Screw and captive clamp terminals. Capacity max: 14 AWG (2.5mm)
Short circuit protection*	In U.S. use fast action fuse 10A type SC; form I Class J, H or equivalent. 10A cylindrical fuses type g1 or N conforming to IEC 337-1B- and VDE 0660-200
Contact rating	Utilization category A300 and Q300. Operating rate: 3600 operations/hour. Load factor: 0.5.
Rated power	Conforms to IEC 947-5-1, duty categories AC 15 and DC 13. Operating rate: 3600 operations per hour. Load factor: 0.5

▲ Direct opening N.C. contacts meet the IEC and EN requirements for positive opening contacts per IEC 947-5-1, EN 60947-5-1; and NEMA ICS-5, part 6 (direct opening action).

* The use of the recommended fuse is mandatory for emergency stop applications. Without a fuse to protect the circuit, the contacts may develop a weld significant enough that the direct (positive) opening contact mechanism may not be able to break through the weld.

AC Voltage and Current Ratings 50-60 Hz

Contact Rating Designation	Thermal Continuous Test Current, Amperes	Maximum Current, Amperes								Voltamperes	
		120 Volts		240 Volts		480 Volts		600 Volts		Make	Break
		Make	Break	Make	Break	Make	Break	Make	Break		
A300	10	60	6.00	30	3.00	7200	720

DC Voltage and Current Ratings

Contact Rating Designation	Thermal Continuous Test Current, Amperes	Maximum Make or Break Current, Amperes			Make or Break at 300 Volts or Less, Voltamperes
		125 Volts	250 Volts	301 to 600 Volts	
Q300	2.5	0.55	0.27	...	69

Snap action contact	For normal stop
AC supply 50-60 Hz Inductive circuit	DC supply
	Power broken in W for 5 million operations

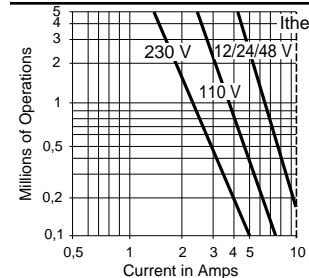

Slow break contact	For emergency stop
AC supply 50-60 Hz Inductive circuit	DC supply
	Power broken in W for 5 million operations

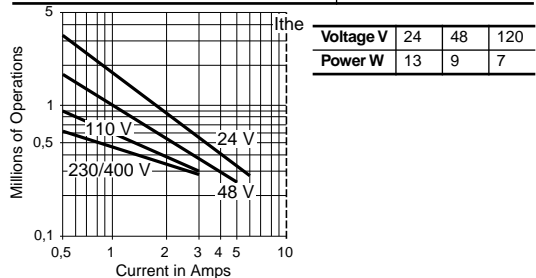

The product life expressed above is based on average usage and normal operating conditions. Actual operating life will vary with conditions. The above statements are not intended to nor shall they create any express or implied warranties as to product operation or life. For information on the limited warranty offered on this product refer to the Square D terms and conditions of sale found in the Square D Digest.

XY2 Cable Pull Selection

XY2CE Cable Pull for up to 165' (50 m) cable length



Right Cable Mount



Left Cable Mount

Emergency Stop (Latching contact - reset by push button - direct ▲ [positive] opening contacts)
Available only with slow break contacts.

The N.O. contacts will close after the N.C. contacts open. They do not change state simultaneously.

The N.C. contacts only should be used in the safety control circuit. The N.O. contacts are provided solely for signaling – NOT for safety functions.

To conform with EN 418 of the European Union Machinery Safety Directive 89/392/EEC safety circuits must use emergency stop devices with 2 N.C. contacts in category 3 or 4 safety control systems. Using devices with 1 N.O. and 1 N.C. contact will not allow the system to meet category 3 or 4 as it would not meet the requirements for redundancy. Cable pull switches with 1 N.O. and 1 N.C. contact would be suitable for Category B, 1 or 2 safety control systems. XY2 cable pull switches are ideal choices for use with PREVENTA Safety Relays.

Reset	Contact	Pilot light (only available on 2 N.O. - 2 N.C. devices)	Catalog Number
Right cable mount			
Standard push button	N.O. + N.C.	No	XY2CE1A150
Booted push button ●	N.O. + N.C.	No	XY2CE1A250
Standard push button	2 N.O. + 2 N.C.	No	XY2CE1A190
Standard push button	2 N.O. + 2 N.C.	Yes ■	XY2CE1A196
Booted push button ●	2 N.O. + 2 N.C.	No	XY2CE1A290
Booted push button ●	2 N.O. + 2 N.C.	Yes ■	XY2CE1A296
Left cable mount			
Standard push button	N.O. + N.C.	No	XY2CE2A150
Booted push button ●	N.O. + N.C.	No	XY2CE2A250
Standard push button	2 N.O. + 2 N.C.	No	XY2CE2A190
Standard push button	2 N.O. + 2 N.C.	Yes ■	XY2CE2A196
Booted push button ●	2 N.O. + 2 N.C.	No	XY2CE2A290
Booted push button ●	2 N.O. + 2 N.C.	Yes ■	XY2CE2A296

● Recommended for outdoors applications where icy conditions are likely.

■ Bulb not included, see spare parts list on page 9. For 220 V † change last digit to 7, bulb included.

▲ Direct opening N.C. contacts meet the IEC and EN requirements for positive opening contacts per IEC 947-5-1, EN 60947-5-1; and NEMA ICS-5, part 6 (direct opening action).

Normal stop+ (momentary action - no reset, no direct▲ [positive] opening contact)
Available only with snap action contacts. Not for use in safety circuits.

	Contact	Pilot light (only available on 2 N.O.-2 N.C. devices)	Catalog Number
Right cable mount	N.O.+N.C.	No	XY2CE3A010
	2 N.O.+2N.C.	No	XY2CE3A020
	2 N.O.+2N.C.	Yes ■	XY2CE3A026
Left cable mount	N.O.+N.C.	No	XY2CE4A010
	2 N.O.+2N.C.	No	XY2CE4A020
	2 N.O.+2N.C.	Yes ■	XY2CE4A026

● Recommended for outdoors applications where icy conditions are likely.

■ Bulb not included, see spare parts list on page 9. For 220V† change last digit to 7, bulb included.

▲ Direct opening N.C. contacts meet the IEC and EN requirements for positive opening contacts per IEC 947-5-1, EN 60947-5-1; and NEMA ICS-5, part 6 (direct opening action).

Options for XY2CE

Description	Designator
Corrosion resistant (only available on devices with booted push button on Emergency Stop devices and all Normal Stop devices) Not available on key operated emergency stop reset nor mushroom head reset versions. Enclosure color changes from beige to an olive-blue color.	Provides a silicone boot, special finish, and copper/brass eyelet. -For non-pilot light devices: 1. Add suffix TK to the part number 2. Change A to C Example: XY2CE1A250 changes to XY2CE1C250TK -For pilot light devices: 1. Add suffix TK to the part number 2. Change A to E Example: XY2CE1A296 changes to XY2CE1E296TK
Low Temperature -40 °F (-40 °C) The minimum temperatures listed are based on the absence of freezing moisture or water.	Non pilot light versions -Change A to C - silicone boot Ex: XY2 CE1A150 changes to XY2 CE1C150 Pilot light versions -Change A to E - silicone boot Ex: XY2 CE1A196 changes to XY2 CE1E196
N.C. + N.C. contact	-Change the 9th digit to 7 (for emergency stop only) Ex: XY2 CE1A150 changes to XY2 CE1A170
Mushroom head reset	-Change the 8th digit to 3 Ex: XY2 CE1A150 changes to XY2 CE1A350
Key operated emergency stop reset (Uses Ronis key No. 421)	-Change the 8th digit to 4. Ex: XY2 CE1A150 changes to XY2 CE1A450

† These devices or components are not UL/CSA.



File E164353
CCN NKCR



File LR44087
Class 3211 03



Acceptable Wire
Sizes 14-24 AWG
Recommended Terminal
Clamp Torque 13 in.-lbs.
General Information 5
Specifications 6
Accessories and
Spare Parts 9, 10
Wiring 15
Dimensions 15



XY2 Cable Pull Selection



XY2CH13150

XY2CH Cable Pull for up to 50' (15 m) cable length

Emergency Stop (Latching contact - reset by push button - direct ▲ [positive] opening contacts)
Available only with slow break contacts.

The N.O. contacts will close after the N.C. contacts open. They do not change state simultaneously.

Only the N.C. contacts should be used in the safety control circuit. The N.O. contacts are provided solely for signaling – NOT for safety functions.

To conform with EN 418 of the European Union Machinery Safety Directive 89/392/EEC safety circuits must use emergency stop devices with 2 N.C. contacts in category 3 or 4 safety control systems. Using devices with 1 N.O. and 1 N.C. contact will not allow the system to meet category 3 or 4 as it would not meet the requirements for redundancy. Cable pull switches with 1 N.O. and 1 N.C. contact would be suitable for Category B, 1 or 2 safety control systems. XY2 cable pull switches are ideal choices for use with PREVENTA Safety Relays.

Reset	Contact	Pilot light	Catalog Number
Standard push button	N.O. + N.C.	No	XY2CH13150
Booted push button ●	N.O. + N.C.	No	XY2CH13250
Mushroom head push button	N.O. + N.C.	No	XY2CH13350
Key operated emergency stop (uses Ronis Key No. 421)	N.O. + N.C.	No	XY2CH13450

Normal stop † (momentary action - no reset, no direct▲ [positive] opening contacts)
Available only with snap action contacts. Not for use in safety circuits.

Reset	Contact	Pilot light	Catalog Number
No Reset Required	N.O. + N.C.	No	XY2CH33010

● Booted push button recommended for outdoors applications where icy conditions are likely.

▲ Direct opening N.C. contacts meet the IEC and EN requirements for positive opening contacts per IEC 947-5-1, EN 60947-5-1; and NEMA ICS-5, part 6 (direct opening action).

† Normal stop devices are not UL/CSA.

Options for XY2CH

Description	Designator
Corrosion resistant (only available on devices with booted push button on Emergency Stop devices and all Normal Stop devices). Not available on key operated emergency stop reset nor mushroom head reset versions. Enclosure color changes from beige to an olive-blue color.	Provides a silicone boot and special finish 1. Add suffix TK to the part number 2. Change the seventh character to 4 Example: XY2CH13150 changes to XY2CH14150TK
Silicone bellows	-Change the 7th digit to 4 Ex: XY2 CH13150 changes to XY2 CH14150
N.C. + N.C. contact	-Change the 9th digit to 7 (for emergency stop only) Ex: XY2 CH13150 changes to XY2 CH13170
Pilot light (not UL/CSA)	-For 24 V, change last digit to 3 -For 48 V, change last digit to 4 -For 120 V, change last digit to 5 -For 230 V, change last digit to 7 Ex: XY2 CH13150 changes to XY2 CH13153



File E164353
CCN NKCR



File LR44087
Class 3211 03



Acceptable Wire
 Sizes 14-24 AWG
 Recommended Terminal
 Clamp Torque 13 in. lbs.
 General Information 5
 Specifications 6
 Accessories and
 Spare Parts 9, 10
 Wiring 15
 Dimensions 15

XY2 Cable Pull Accessories and Spare Parts

The Accessories and Spare Parts below are listed for either the XY2CE or XY2CH separately.

XY2CE Accessories

Description	Sold in lots of	Catalog Number
End spring for cables longer than 83 ft (25m) ▲ Can also be used on shorter length cables.	1	XY2CZ702
Lock out kit (Yellow) Contains padlock attachment and two tamper proof cover mounting screws with special key	1	XY2CZ916
Turnbuckle to tighten actuating cable. Threaded eye bolt is M6 x 60 + locknut	1	XY2CZ404
Tensioning device. Used instead of a turnbuckle, provides for easy adjustment right on the switch.	1	XY2CZ203
Tensioning device + support. Used instead of a turnbuckle, provides for easy adjustment right on the switch, and also provides the first cable support for the actuating cable.	1	XY2CZ917

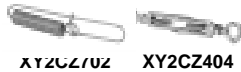

XY2CZ702 XY2CZ404



XY2CZ203 XY2CZ917

Spare Parts

Pilot light body Direct voltage to 130 V, bulb not supplied Direct voltage for 230 V, bulb not supplied	1	XY2CZ906	
	1 1 1	XY2CZ907	
Pilot light head	1	ZB2BV04	
Red lens	1	ZB2BV014	
Yellow lens	1	ZB2BV015	
BA9s incandescent bulb	24 V – 2.6 W	1	DL1CE024
	48 V – 2.6 W	1	DL1CE048
	130 V – 2.6 W ♦	1	DL1CE130
Dust and damp protecting bellows	Polychloroprene (std.)	1	XY2CZ901
	Silicone	1	XY2CZ903



XY2CZ906 ZB2BV04



ZB2BV014



DL1CE024 XY2CZ901

♦ This lamp is used in both 120 V and 230 V applications. For 230 V application, a pilot light body with resistor (XY2CZ907) is used in the switch.

XY2CH Accessories

Description	Sold in lots of	Catalog Number	
End spring ▲	1	XY2CZ703	
Pilot light Yellow (Not UL/CSA)	24 V	1	XY2CZ0024H4
	48 V	1	XY2CZ0048H4
	120 V	1	XY2CZ0130H4
	220...240 V	1	XY2CZ0230H4



XY2CZ0130H4

Spare Parts

Dust and damp protecting bellows	Polychloroprene (std.)	1	XY2CZ902
	Silicone	1	XY2CZ904
Pilot light bulb Screw fitting for XY2 CH Max. diameter 17mm Length 34mm	24 V – 6 W	10	DL1AA024
	48 V – 6 W	10	DL1AA048
	130 V – 6 W	10	DL1AA127
	230 V – 6 W	10	DL1AA220



XY2CZ902

▲ The use of an end spring is strongly advised in the recommendations of the European standard EN616, when using cable pull devices on continuous duty mechanical handling equipment and systems.



XY2 Cable Pull Accessories and Spare Parts

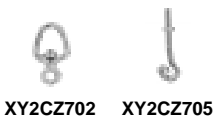

XY2CE and XY2CH Accessories (These accessories are suitable for both XY2CE and XY2CH)

Description	Sold in lots of	Catalog Number
Cable kits		
34.4 ft (10.5 m) (For use with XY2CH)	1	XY2CZ9310
83.7 ft (25.5 m) (For use with XY2CE in medium length applications)	1	XY2CZ9325
165.6 ft (50.5 m) (For use with XY2CE in maximum length applications)	1	XY2CZ9350
Galvanized steel cable with red jacket 1/8" (3.2 mm) diameter. The red cable jacket meets EN requirements for emergency stop actuators to be red.	Length 34.4 ft (10.5 m)	XY2CZ301
	Length 83.7 ft (25.5 m)	XY2CZ302
	Length 165.6 ft (50.5 m)	XY2CZ305
Cable clamps	Single; 3.5mm diameter cable (max.)	XY2CZ503
	Double; 3.5mm diameter cable (max.)	XY2CZ513
	Clamp; 3.5mm diameter cable (max.)	XY2CZ523
Cable support	Fixed (5/16" coarse thread, 0.35" deep)	XY2CZ601
	Swivelling	XY2CZ602
	Pulley support (to be used with Pulley XYZCZ708)	XY2CZ705
Pulley, 5mm max. diameter cable (to be used with XYZCZ705 Pulley Support)	1	XY2CZ708
Wire and protective guard for 3 – 3.5mm diameter cable. Guard is used to protect cable when securing to the switch, turnbuckles, and end springs, etc. The cable is placed in the groove of the guard so the guard comes in contact with the switch, turnbuckle, or end springs – instead of the cable itself. Reduces stress and strain on cable.	10	XY2CZ701

▲ The use of an end spring is strongly advised in the recommendations of the European standard EN616, when using the cable pull devices on continuous duty mechanical handling equipment and systems.

XY2CE and XY2CH Spare Parts (These spare parts are suitable for both XY2CE and XY2CH)



Description	Sold in lots of	Catalog Number
Contact block	Slow break, N.O. + N.C. (emergency stop)	1 Not available separately
	Slow break, N.C. + N.C. (emergency stop)	1 Not available separately
	Snap action, N.O. + N.C. (normal stop)	1 XESP2151
Reset operators	Flush with marking R	1 ZA2BA639
	Booted	1 ZA2BP6
	Emergency stop head 30 mm diameter – blue	1 ZA2BC64
	Key operated emergency stop – blue (Ronis Key No. 421)	1 ZA2BS06212
Key	Ronis No. 421	1 Q99900911



OPERATING PRINCIPLES – XY2CH

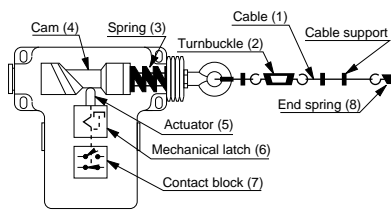

Normal position

The cable (1) is tightened by the turnbuckle (2) and held in a normal position by the spring (3). As the turnbuckle is turned, the cam (4) moves from left to right, and allows the actuator (5) to be positioned according to the particulars of the desired setting (see page 15).

The mechanical latch is unlocked when the N.C. contact is in the locked position.

Tripping the device

Operating or breaking the cable results in the cam shifting position.

The active part of the cam presses down the actuator (5), simultaneously causing the N.C. contact (7) to open and the mechanical latch (6) to maintain it in its open position. Cable supports ensure the transmission of the cable tension into the axis of the switch cam.

NOTE: For greater safety, an end spring (8) is recommended at the far end of the cable (1) allowing the cable to be moved right or left, especially for cables 80' or longer. The use of an end spring is strongly advised in the recommendations of the European standard EN616, when using the cable pull devices on continuous duty mechanical handling equipment and systems.

DEFINITIONS

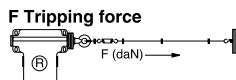

The value of the **tension (F) along the cable** which trips the switch. Adjustable value according to cam position (see table on page 12).

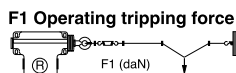

The value of the **traction force (F1)** applied by the operation **perpendicular to the cable** which trips the switch. Adjustable value according to the table on page 12.

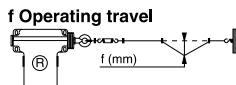

The distance (f) travelled by the operator i.e. operator's hand, between the normal position and the tripping point. Adjustable value according to the table on page 12.

GENERAL PURPOSE ADJUSTMENT METHOD

XY2CE

Cable traction force

Adjust either directly when mounting the cable or using a turnbuckle positioned near the switch but **after the first cable support**. For standard adjustment the **tension indicator should be in the middle of the range**.

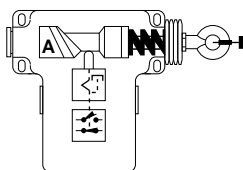

Position A

Operating travel

The tripping point is adjusted by the rotating cam marked by letters A to F. Position A corresponds to the minimum travel. Position F corresponds to the maximum travel.

NOTE: The switches are delivered from the factory in position A.

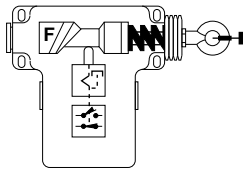

Position F

XY2CH

XY2CH has two viewing windows to aid in adjusting cable tension and resetting the switch. When the cable tension indicator is in mid-range in its viewing window, the reset button should be pushed to reset the device. When reset, a green indicator is visible in the contact viewing window. When the switch is tripped, a yellow indicator is visible in the contact viewing window and the cable tension indicator is at the edge of its viewing window.



XY2 Cable Pull Installation and Adjustment

SPECIFIC ADJUSTMENT METHOD – XY2CE

When the travel or tripping force is specified the cable tension and the cam position should be adjusted based on the values below. (Refer to General Purpose Adjustment Method on page 11.) For each position of the cam, the values of the operating travel and force (F1) corresponding to the minimum and maximum cable tension are tabulated below.

Cable characteristics: length = 165 ft. (50 m); maximum elongation of cable to be no more than 0.00834 inches per foot (.7mm/m), equivalent to a maximum co-efficient of expansion of 0.07%, based on a 108 °F (60 ° C) temperature variance.

Switch Type	Cam Position		Cable Tension (Axial)		2 m Between Supports				5 m Between Supports				Tripping Force (Axial)	
			F		f		F1		f		F1		N	Lbf
			N	Lbf	mm	IN	N	Lbf	mm	IN	N	Lbf		
XY2CE	A	Min.	145	32.6	94.0	3.7	59	13.2	160	6.30	20	4.5	323	72.7
		Max.	195	43.9	81.3	3.2	57	12.8	160	6.30	32	7.2		
	B	Min.	150	33.8	104.1	4.1	83	18.7	170	6.69	24	5.4	333	74.9
		Max.	205	46.1	91.4	3.6	76	17.1	175	6.89	38	8.6		
	C	Min.	152	34.2	114.3	4.5	90	20.2	180	7.09	28	6.3	352	79.3
		Max.	215	48.4	106.7	4.2	83	18.7	190	7.48	44	9.9		
	D	Min.	155	34.9	124.5	4.9	98	22.0	190	7.48	32	7.2	372	83.7
		Max.	225	50.6	114.3	4.5	89	20.0	200	7.87	49	11.0		
	E	Min.	160	36.0	134.6	5.3	109	24.6	200	7.87	35	7.9	402	90.4
		Max.	235	52.9	124.5	4.9	104	23.5	210	8.27	56	12.6		
	F	Min.	165	37.1	144.8	5.7	117	26.4	205	8.07	39	8.8	421	94.8
		Max.	245	55.1	134.6	5.3	111	24.9	220	8.66	60	13.5		
XY2CH	—	—	100	22.5	—	—	—	—	160	6.30	20	4.5	—	—



SETTING-UP

XY2CH

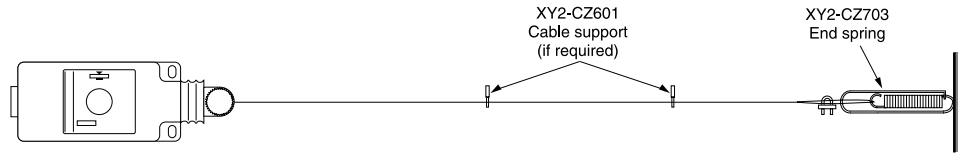

XY2CE

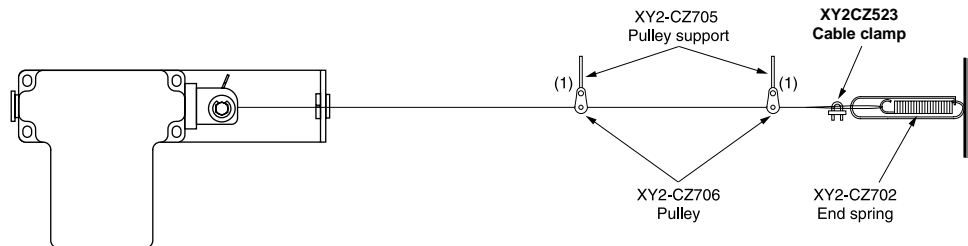

XY2CE + XY2CZ917

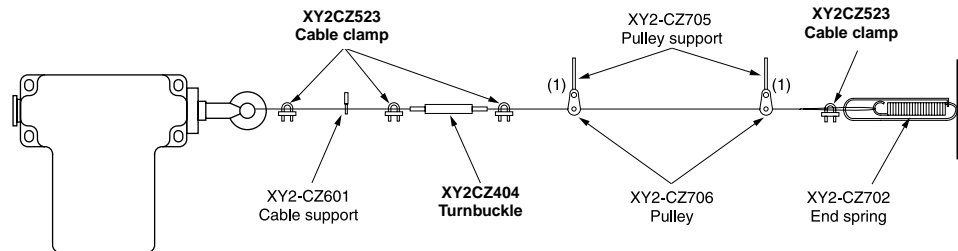

APPLICATION AND INSTALLATION RECOMMENDATIONS

The XY2 cable pull switches are based on the taut cable principle, which means the cable must be tight and have a tension applied to allow the switch to be reset and work properly. This is different from slack cable switches where the cable is normally slack and is only tight when pulled. The benefit of the taut cable principle is that the operator knows that if the cable is taut, the machine can be shut down. If slack cable switches are used, the operator is not assured the cable is affixed properly at the switch and may be unsure that when the cable is pulled the machine will stop.

The distance an operator must pull the cable on a slack cable switch depends on the operator's distance from the switch and the amount of slack in the cable. An operator close to the switch needs to take up much less slack in the cable before tripping the switch than an operator at the far end of the installation. With a taut cable switch, the operating force and distance the cable needs to be pulled is the same throughout the installation. The taut cable style of device is more reliable in an emergency situation.

Effects of Friction

To operate properly, the cable must be tight with tension on it, and the cable must have a minimum of friction. Care must be taken in the machine design to insure that the system avoids ANY friction between the cable on the machine parts or components, and moving parts on the machine or material handling system.

- The cable must be free of motion on its supports. It should not lay against the supports nor rub on them except when the cable is pulled by an operator.
- The cable must not have weights attached nor applied to it as a standard part of the application.
- The application must be designed to reduce friction as low as possible. This is accomplished by using reduced friction pulleys and guides.
- The cables should never be run through conduit or tubing.



XY2 Cable Pull Application Information

Cornering

The operating cable should be installed so that the cable run is straight, but this cable can also be routed around corners using pulleys. If the cable deviates from a straight line, pulleys **must** be used. The effects of friction could be more noticeable if the cable is not installed correctly and with a minimum of friction.

- DO NOT allow the cable to turn corners or change direction using only cable supports.
- A pulley **must** be used when routing cable around corners, regardless of the angle. Use a pulley whenever direction is changed even slightly. The pulley must have freedom of movement on its mounting to maintain the self-alignment of the cable.
- If a fixed pulley is used, a cable support should be positioned within 4 inches (10 cm) of both sides of the pulley.
- The total sum of the angles for the cable bends or turns should be no more than 180°.
 - i.e.: qty of two 90-degree angle turns is acceptable.
 - i.e.: qty of three 60-degree angle turns is acceptable.
 - i.e.: qty of three 90-degree angle turns is not acceptable.

Temperature

Temperature variations in the area where the cable pull switch is installed can affect the adjustment of the switch. The cable expands (becomes longer) when temperature increases, and contracts (shrinks) when temperature decreases. Wide temperature variations should be avoided where possible. If temperature variations are significant, the adjustment of the cable and switch must be checked at regular intervals. If the switch is not adjusted properly during installation, temperature variations could affect cable length and trip the switch without operator intervention. If this occurs, the switch needs to be readjusted.

Temperature variances can come from any of the following:

- Seasonal temperature changes in non-climate controlled areas.
- Freezers and refrigeration equipment which are cold during production but are brought to room temperature for cleaning.

- Equipment that is used to heat treat or cook material during production but is brought to room temperature for cleaning.
- Equipment which is at room temperature (or lower temperatures) for production but is cleaned with hot water or steam.
- Equipment placed near windows and large glass areas: sunlight could cause an expansion of the cable where an overcast day may cause a contraction of the cable.

*Note: Routing the cable through both hot and cold production areas with the same cable could require more frequent adjustment and **may** not allow proper adjustment throughout the production cycle. Example: A cable pull switch on a production line where the product is cooked and then flash frozen in a short distance. Some sections of the cable could be very hot, and other sections very cold, and other sections at room temperature. Temperature variations in any of these areas could affect the overall adjustment of the cable. Where such variations occur, we recommend the use of multiple cable pulls.*

General Guidelines

- Be sure the cable remains accessible and visible to the operators for its entire length.
- The switch, cable supports, and other hardware must be rigidly mounted on the machine or application. If these mountings are not secure and rigid, the tension on the cable could be changed and the switch will trip. Mounting points must not move when the cable is pulled.
- Supports are not to be placed on moveable parts of the application.
- Cable lengths used must not be in excess of maximum lengths listed for the particular cable pull switch.
- The turnbuckle allows for the proper adjustment of the switch, and must be mounted close to the switch to ease and simplify adjustment of the system.
- The turnbuckle locknuts should be tightened securely.
- The first cable support should be within 4 inches (10 cm) of the switch.
- The sheath around the end of the cable must be removed when inserted into the cable clamps to assure metal to metal contact. Failure to remove sheathing could cause slipping of the cable, reducing the tension on the cable, and switches may not perform to published specifications.



XY2 Cable Pull

Wiring, Operating and Approximate Dimensions

Wiring diagrams

For the versions with two contact blocks the left one is identified as A and the right one is identified as B. The markings are permanently inscribed on the mounting fixture above the contact blocks. Ex. B 21-22 is the normally closed contact of the right contact block.

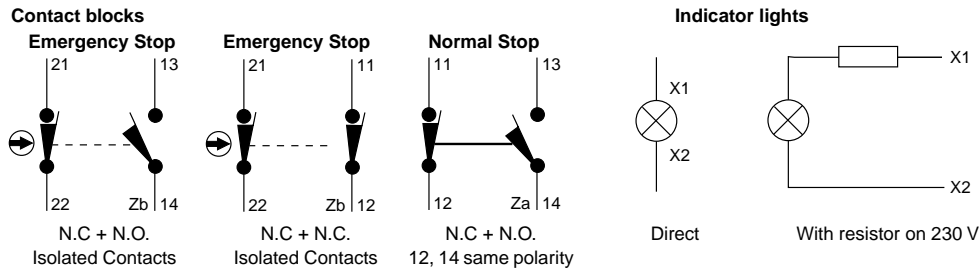

NOTE: When the emergency stop switch operates in conjunction with solid state controls, i.e. PLCs, the supply for the safety functions must be disconnected independent of the PLC.

Operating instructions

Indicator displays

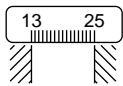

The indicators define the maximum cable tension adjustment zone. The cable tension is adjusted via the turnbuckle. **The device will not function outside this zone.**

For general purpose adjustment the indicator should be in the middle of the window.

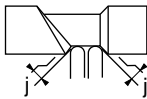

Adjustment limits for effective operating

In a normal position, adjustments should be made so that there must be a play (J) between the actuator and the conical parts of the cam.

Cable supports

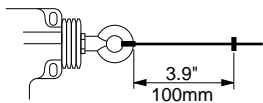

It is recommended to space supports along the entire length of the cable at 6 to 16 foot (2 to 5 meter) intervals. **Cable supports ensure the transmission of the cable tension in the axis of the switch cam. The first one after the switch is mandatory for correct operation (3.9", 100 mm).** Also, if pulleys are used to change the direction of the cable, **cable supports at 4" before and after the pulley are mandatory.**

NOTE: Use supports with 0.8" (20 mm) maximum height H with respect to the product mounting plate.

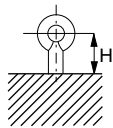

Cable characteristics

Recommended cable diameter is 1/8" (3.2 mm). However, any galvanized steel cable (aircraft type) less than 9/32" (7 mm) diameter can be used, provided it meets the following criteria: Maximum elongation of cable to be no more than 0.00834" per ft. (.7 mm/m), which is equivalent to a maximum co-efficient of expansion of 0.07%, based on a 140 °F (60 °C) temperature variance.

Overall dimensions

Emergency stop push button option with key inserted is shown

XY2CE

XY2CH

Dual Dimensions: INCHES
Millimeters

