

THIS DRAWING IS UNPUBLISHED. RELEASED FOR PUBLICATION
 © COPYRIGHT - By - ALL RIGHTS RESERVED.

LOC		DIST		REVISIONS			
P	LTR	DESCRIPTION		DATE	DWN	APVD	
CM	00	S1	REVISED PER ECO-11-004587	11MAR11	RK	HMR	

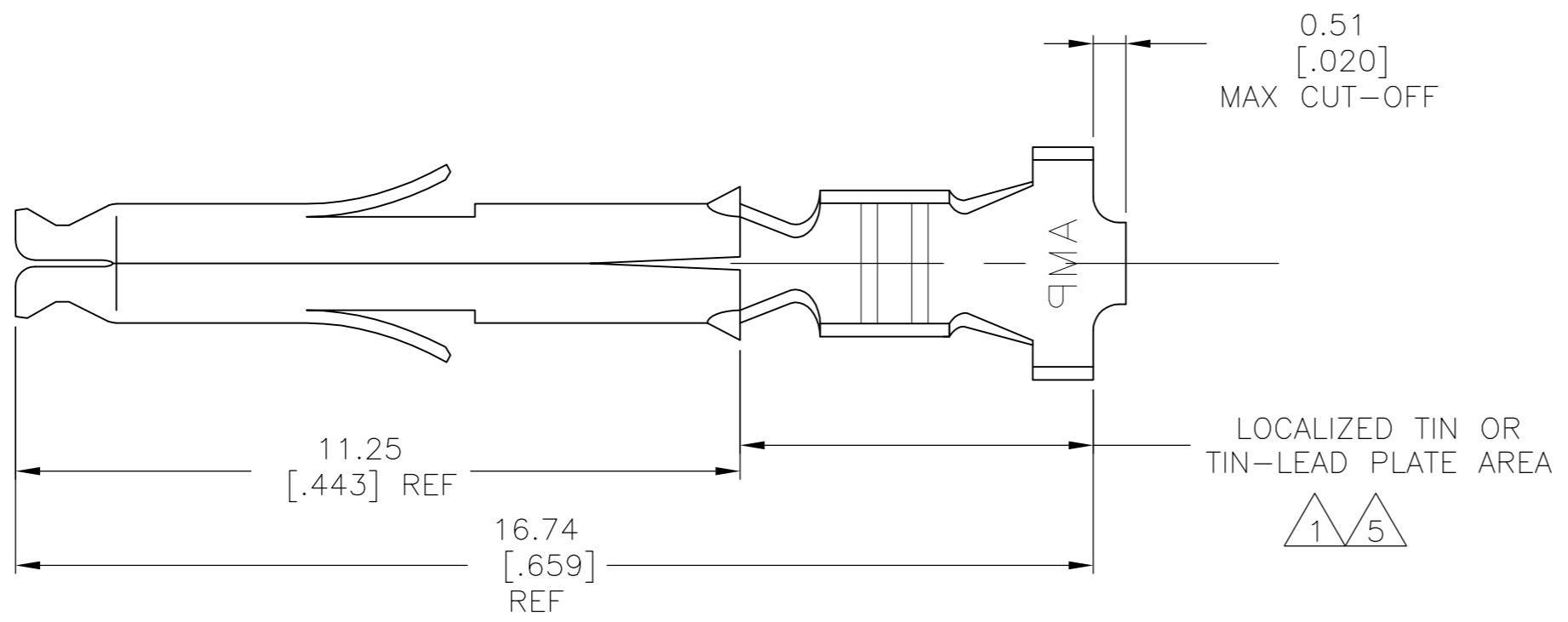

- 1 0.00076 [0.00030] MIN GOLD IN LOCALIZED GOLD PLATE AREA AND 0.00254 [0.00100] MIN BRIGHT TIN-LEAD IN LOCALIZED TIN-LEAD PLATE AREA OVER 0.00130 [0.00050] MIN NICKEL.
- 2 WIRE RANGE: 0.3 - 0.9mm² (22-18 AWG).
- 3 INSULATION RANGE: 1.50-2.39[.059-.094] DIA.
- 4 DIMENSIONS IN BRACKETS ARE IN INCHES.
- 5 0.00076 [0.00030] MIN GOLD IN LOCALIZED GOLD PLATE AREA AND 0.00254 [0.00100] MIN BRIGHT TIN IN LOCALIZED TIN PLATE AREA OVER 0.00130 [0.00050] MIN NICKEL.

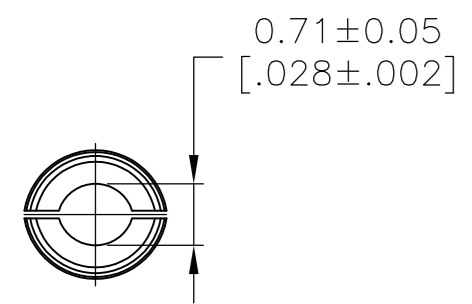
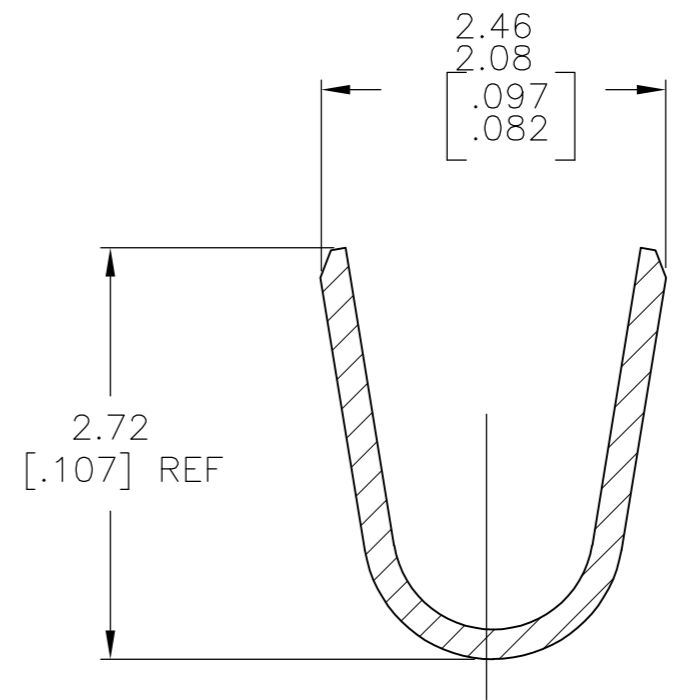
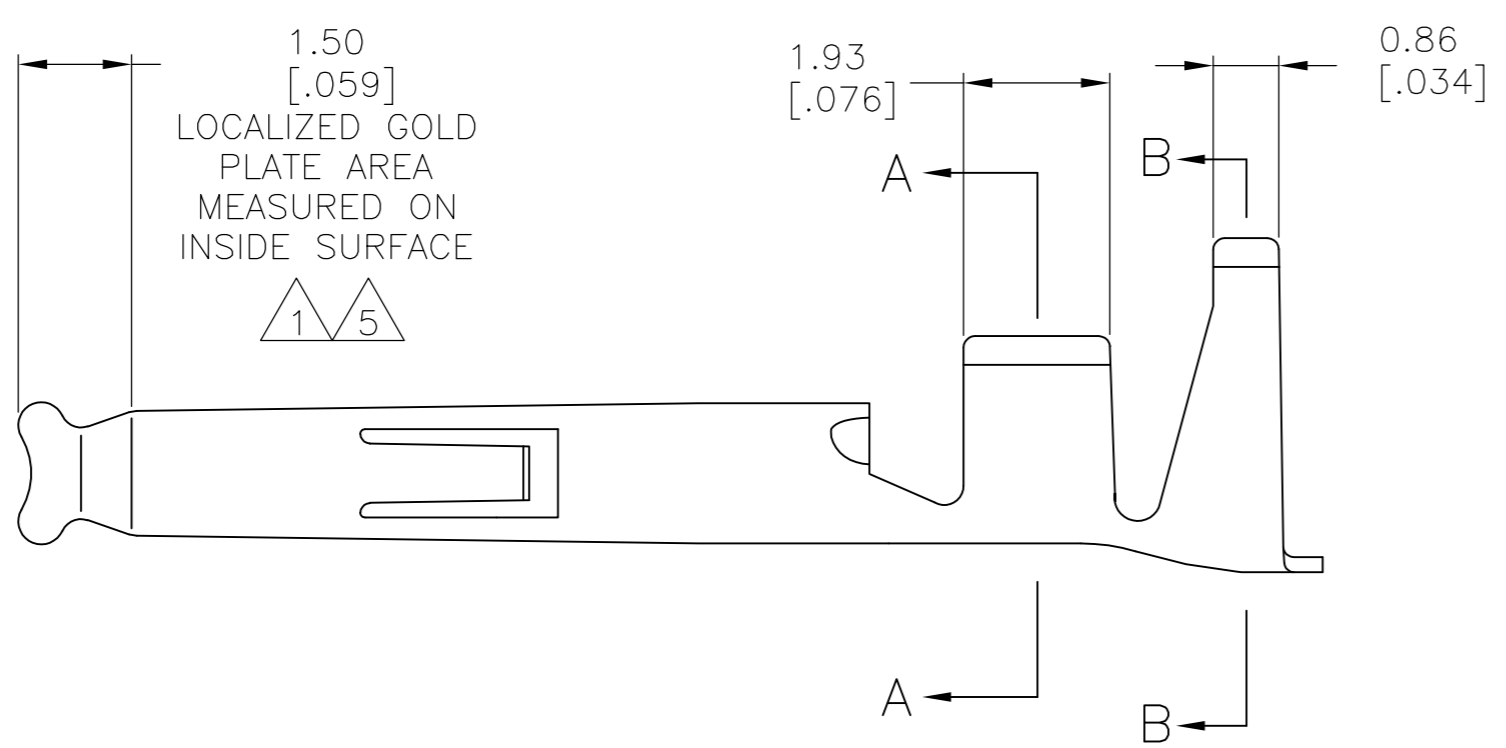

SECTION A-A
SCALE 20:1

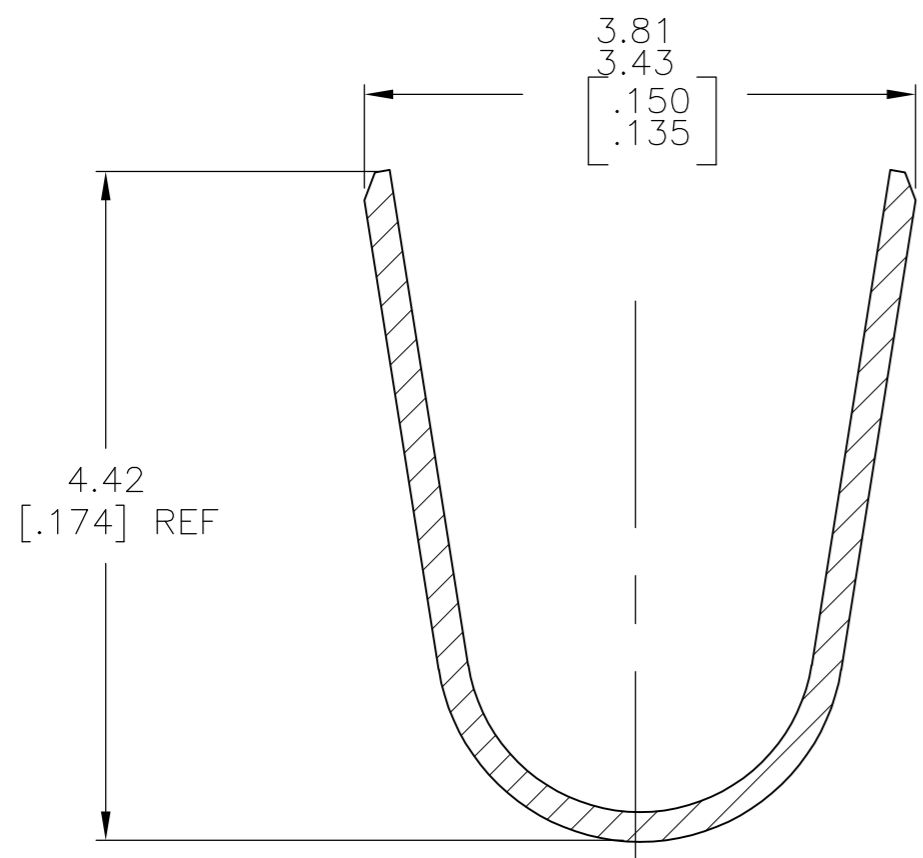

SECTION B-B
SCALE 20:1

5	0.20 [0.008] PH BRZ	1-770904-1
5	0.20 [0.008] BRASS	1-770904-0
1	0.20 [0.008] PH BRZ	770904-6
PRE-TIN	0.20 [0.008] PH BRZ	770904-4
1	0.20 [0.008] BRASS	770904-3
PRE-TIN	0.20 [0.008] BRASS	770904-1
FINISH	MATERIAL	PART NUMBER

THIS DRAWING IS A CONTROLLED DOCUMENT.		DWN S. HOOVER 17OCT02	STE TE Connectivity	
DIMENSIONS: mm [INCHES]		CHK C. JONES 17OCT02		
TOLERANCES UNLESS OTHERWISE SPECIFIED:		APVD C. JONES 17OCT02	NAME	
0 PLC ± -	1 PLC ± -	PRODUCT SPEC	SOCKET, MINI UNIVERSAL MATE-N-LOK(TM)	
2 PLC ± -	3 PLC ± 0.15[0.006]	APPLICATION SPEC	SIZE A2	CAGE CODE 00779
4 PLC ± -	ANGLES ± 1°	WEIGHT -	DRAWING NO C=770904	RESTRICTED TO -
MATERIAL -	FINISH -	CUSTOMER DRAWING	SCALE 10:1	SHEET 1 of 1
			REV S1	