

Voltech PS1000 Power Switch

Solid-state Switch for Inrush Current Measurement



The Voltech PS1000 solid-state switch controls the turn-on of an AC supply to allow accurate measurement of the inrush current into an AC load. It is designed for use with Voltech power analyzers such as the PM100, PM300 or PM3000A.

A push-button switch on the PS1000 front panel allows the turn-on point of the AC supply to be selected between the zero-crossing or peak value of the AC voltage waveform. Trigger point accuracy for supply frequencies in the range from 40Hz to 440Hz is automatically maintained by a phase-locked loop in the unit.

A fully isolated trigger output is provided on a rear-panel BNC connector, so that other equipment, such as a storage oscilloscope, can be triggered when the PS1000 turns the AC supply on.

Self-powered from the AC supply that it controls, the PS1000 connects directly into the load circuit via 4mm safety sockets on its front panel. It is housed in a fully insulated, impact resistant ABS case.

Specification

AC Supply Voltage:	80V to 265V rms AC
AC Supply Frequency:	40Hz to 440Hz
Peak Inrush Current:	200A maximum
Protection:	Fuse 5AT HRC 20mm on rear panel
External Trigger Output:	Amplitude: 2V Pulse Width: 5 μ s Isolation: 2.5kV rms (sinewave) to the front-panel AC supply terminals
Environmental Conditions:	Operating Temperature: 5° to 40°C Storage Temperature: -40° to +70°C Humidity: 10% to 80% RH, non-condensing
Conformity:	BS EN61010-1, Class II, Installation Category II, Pollution Degree 2

PS1000 Power Switch

PS1000 Power Switch for Inrush Current Measurement

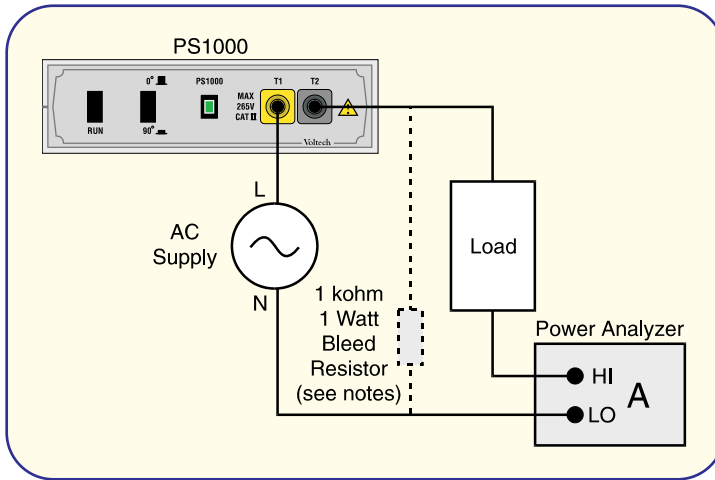

Operation

- Connect the PS1000 as shown in the circuit illustration opposite.
- Set the trigger point on the PS1000 to 0° (zero crossing) or 90° (peak voltage), as required.
- Set up the power analyzer for inrush current measurement.
- Energize the AC supply.
- Press the RUN button on the front panel of the PS1000.

On pressing RUN, the PS1000 will connect the AC supply to the load at the next programmed trigger point (0° or 90°) on the source voltage waveform, disconnecting it again at the 180° point when the voltage falls to zero. The front panel LED will be illuminated when the voltage is applied.

You may select the trigger point that gives the maximum inrush current depending on the type of load:

- Inductive loads such as transformers and motors -0°
- Resistive loads such as lamps and heaters -90°
- Capacitive loads such as switch-mode power supplies -90°

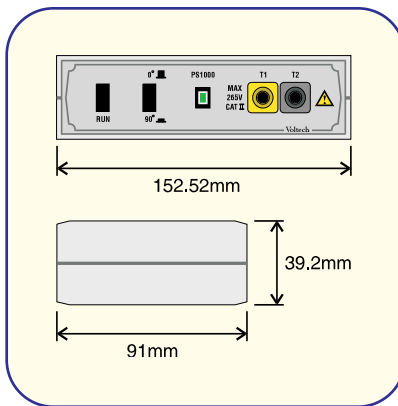
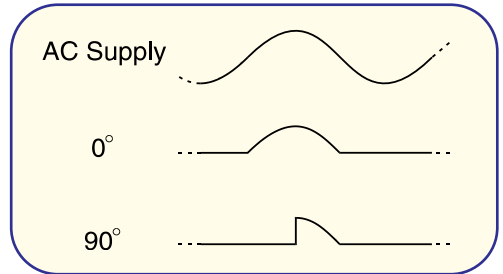

Notes

Because the PS1000 is self-powered, a leakage current of a few mA flows through the unit, even when its solid-state switch is in the 'OFF' condition. In applications where the load is capacitive, this current will prevent proper discharge of the capacitor between measurements. The problem can be simply resolved by fitting a 1000Ω, 1-watt bleed resistor in the position shown in the circuit, where it will provide the necessary discharge path without affecting the measurement of peak inrush currents in the load.

It is recommended that shrouded safety terminals are used when making connections. High voltages may exist while using this product, which may be dangerous if these connection instructions are not followed.

PS1000 Power Switch

Voltech Instruments Ltd.

148 Sixth Street, Harwell International Business Centre
Harwell, Didcot, Oxon, OX11 0RA, UK
Tel: +44 (0)1235 834555
Fax: +44 (0)1235 835016
E-mail: sales@voltech.co.uk

Voltech Instruments Inc.

11637 Kelly Road, Suite 306
Fort Myers, FL 33908, USA
Tel: +1 239 437 0494
Fax: +1 239 437 3841
E-mail: sales@voltech.com

Voltech
www.voltech.com

While every care has been taken in compiling the information for this publication, Voltech Instruments cannot accept legal liability for any inaccuracies. Voltech Instruments has an intensive program of design and development that may alter product specifications. Voltech Instruments reserves the right to alter specifications without notice and whenever necessary to ensure optimum performance from its product range. No part of this publication may be reproduced, stored in a retrieval system, or transmitted in any form, or by any means, electronic, mechanical, photocopying, recording or otherwise, without prior permission of Voltech Instruments.

