

SPECIFICATION FOR APPROVAL

承 認 書

Description : Piezo Audio Transducer

Kingstate Part No. : KPEG1600NC

Customer's Model No. : _____

Specification No. : PKD-7622

Number Of The Edition : 1.2

CUSTOMER'S APPROVED SIGNATURE		

志豐電子股份有限公司 KINGSTATE ELECTRONICS CORP.



Address: 10F, No. 69-11, Sec. 2, Chung Cheng E. Rd., Tamshui County, Taipei Hsien, Taiwan, R.O.C.

International sales dept.: TEL:886-2-2809-5651 FAX:886-2-2809-7151

Domestic sales dept.: TEL:886-2-2809-0668 FAX:886-2-28096748

<http://www.kingstate.com.tw>

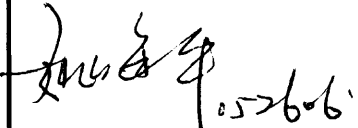
Approved by	Checked by	Issued by
 052606	何明輝 2006.5.26	Fei 5/26/06'

A. SCOPE 範疇

This specification applies piezo audio transducer, **KPEG1600NC**
 此規格書適用於壓電式蜂鳴器, **KPEG1600NC**

B. SPECIFICATION 規格

No.	Item	Unit	Specification	Condition
1	Operating Volt. 操作電壓	Vp-p	MAX. 150	
2	Current consumption 消耗電流	mA	MAX. 30	at 90Vp-p,sine wave,3.5KHz.
3	Sound pressure level 輸出音壓	dB	MIN. 95	at 100cm/90Vp-p,sine wave,3.5KHz.
4	Electrostatic capacity 靜電容量	pF	30,000 ± 30%	at 1KHz/0.25V
5	Operating temp. 操作溫度		-20 ~ +60	
6	Storage temp. 儲存溫度		-30 ~ +70	
7	Dimension 尺寸	mm	54.5 x H23.0	See appearance drawing 請參照外觀尺寸圖
8	Weight (MAX) 重量	gram	35.0	
9	Material 材質		ABS UL-94 1/16" HB	
10	Terminal 端子		Terminal	See appearance drawing 請參照外觀尺寸圖
11	Environmental Protection Regulation 環保法規		RoHS	

C. APPEARANCE DRAWING 外觀尺寸圖

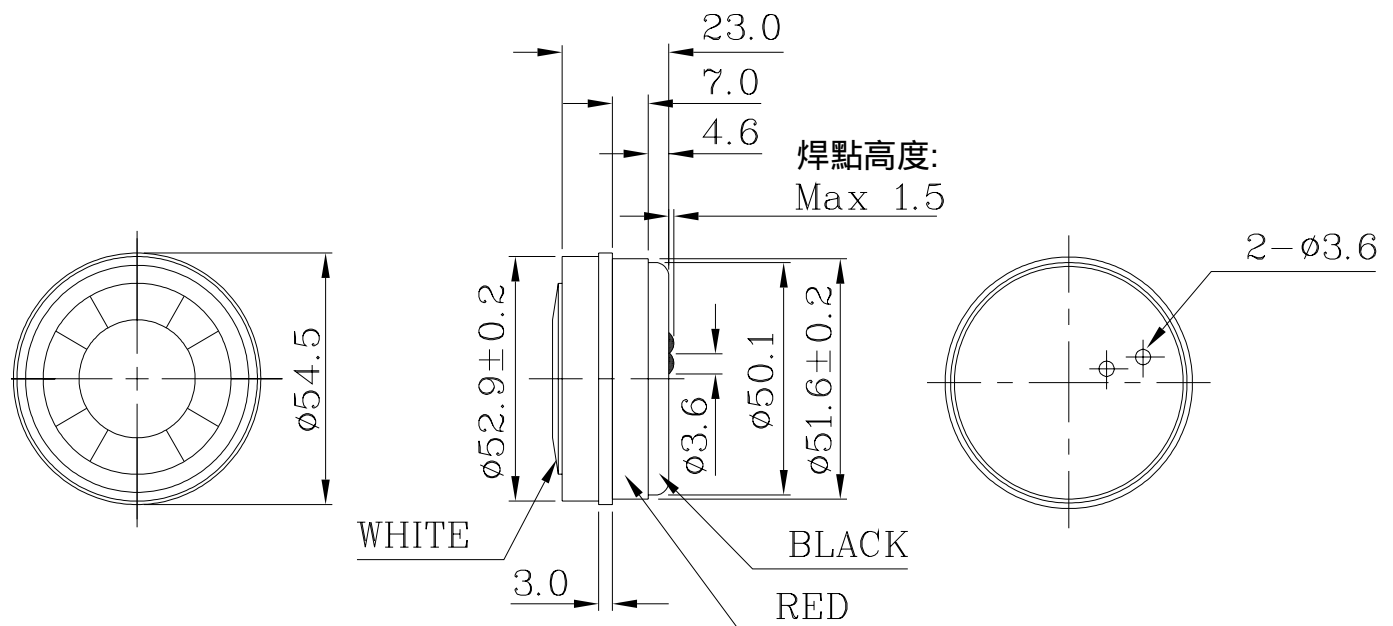

Tol : ± 0.5

Unit: mm

D. TYPICAL FREQUENCY RESPONSE CURVE 頻率響應曲線

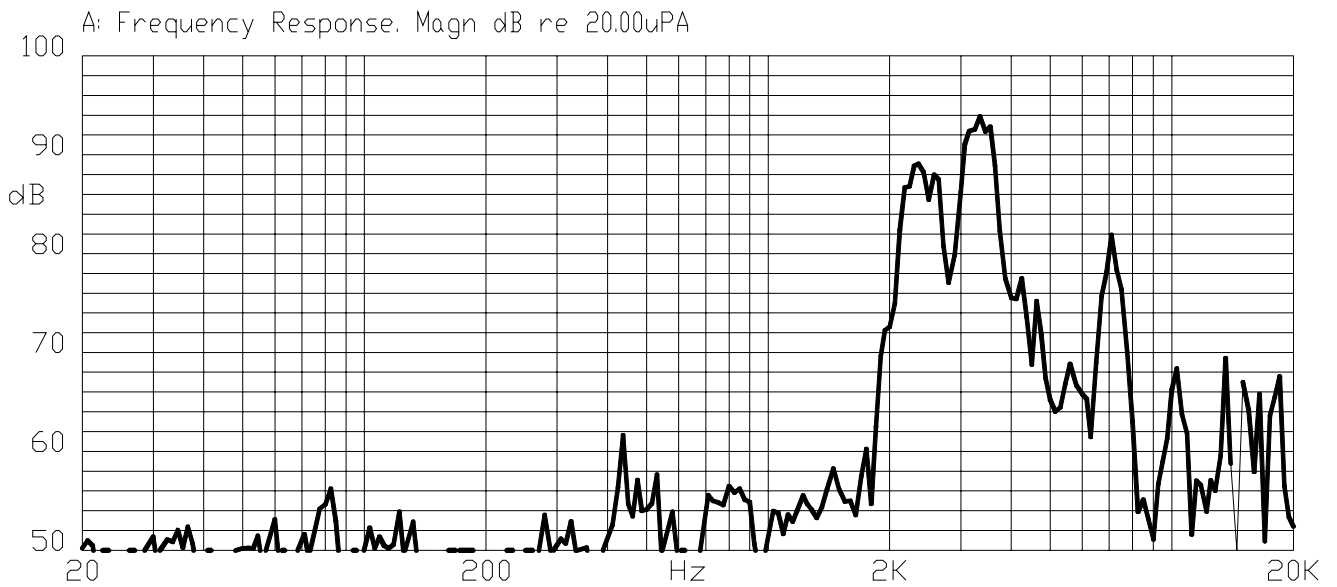

E. MEASURING METHOD 測量方法

S.P.L. Measuring Circuit 音壓測試接線圖

Input Signal: 90Vp-p, 3.5kHz, Sine Wave

輸入信號: 90Vp-p, 3.5kHz, 正弦波

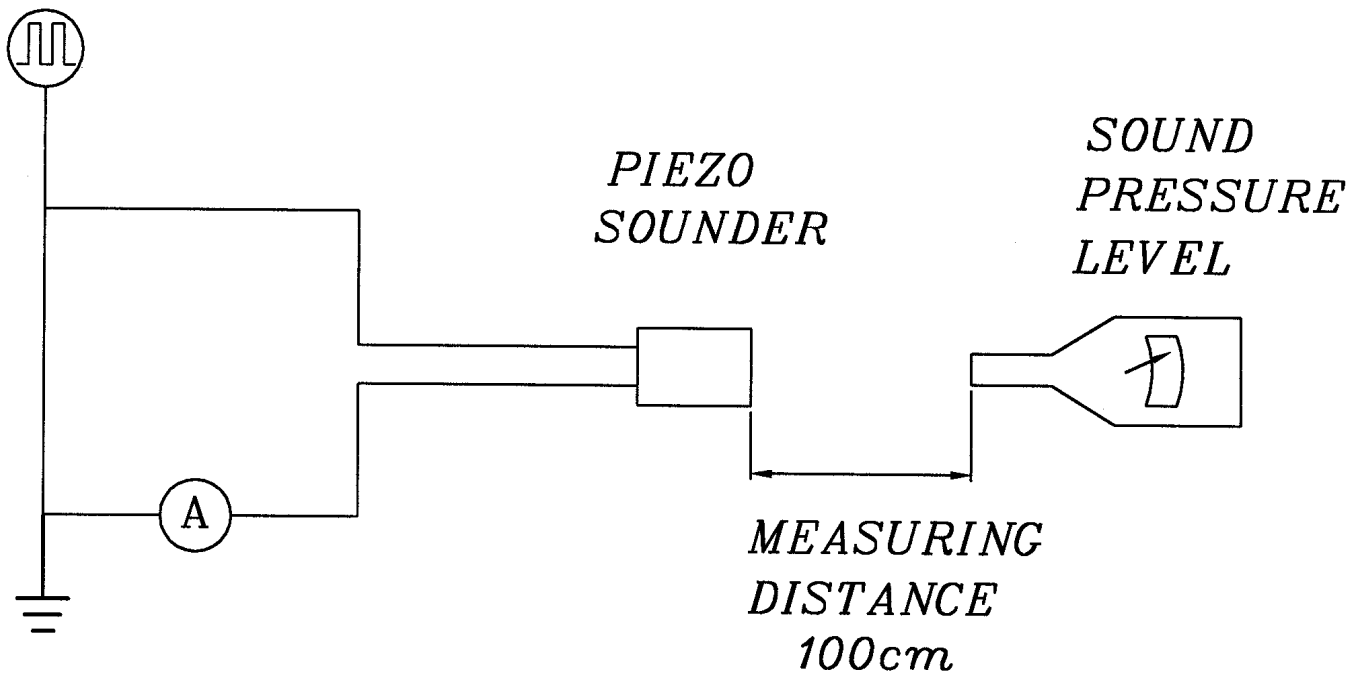

Mic : RION S.P.L meter UC30 or equivalent

Mic : RION 噪音計 UC30 或同等品

S.G : Hewlett Packard 33120A Function Generator or equivalent

S.G : Hewlett Packard 33120A 函數信號產生器或同等品

F. MECHANICAL CHARACTERISTICS 機械特性

No.	Item	Test Condition	Evaluation standard
1	Vibration 振動測試	Buzzer shall be measured after being applied vibration of amplitude of 1.5mm with 10 to 55hz band of vibration frequency to each of 3 per-pendicular directions for 2 hours. 振動週波數 10 ~ 55HZ、全振幅 1.5mm 於 X.Y.Z 3 個方向,各 2 小時	The value of oscillation frequency/ current consumption should be in $\pm 10\%$ compared with initial ones .The SPL should be in $\pm 10\text{dB}$ compared with initial one. 諧振頻率與消耗電流變化量須在 $\pm 10\%$ 內. 輸出音壓變化量須在 $\pm 10\text{dB}$ 內.
2	Drop test 落下測試	The part only shall be dropped from a height of 75cm onto a 40mm thick wooden board 3 times in 3 axes (X.Y.Z). (a total of 9 times). 單體從 75 公分高處, X.Y.Z.3 個方向,各 3 回,落於 40mm 厚木板上.	

G. ENVIRONMENT TEST 環境測試

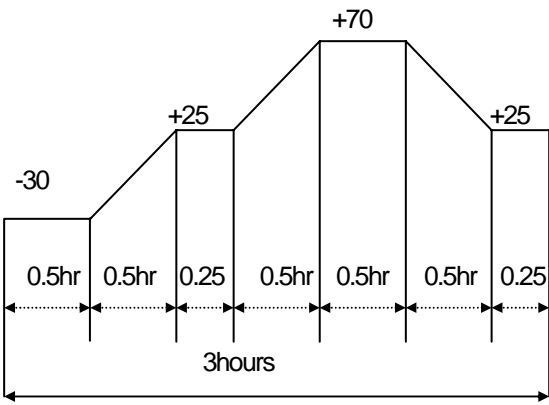
No.	Item	Test Condition	Evaluation standard
1	High temp. test 高溫測試	After being placed in a chamber at +70 for 240 hours 置於+70 環境中 240 小時	Being placed for 4 hours at +25 , buzzer shall be measured. The value of oscillation frequency/ current consumption should be in $\pm 10\%$ compared with initial ones .The SPL should be in $\pm 10\text{dB}$ compared with initial one. 經測試後, 靜置於+25 (室溫) 環境中 4 小時後, 諧振頻率與消耗電流變化量須在 $\pm 10\%$ 內. 輸出音壓變化量須在 $\pm 10\text{dB}$ 內.
2	Low temp. test 低溫測試	After being placed in a chamber at -30 for 240 hours 置於-30 環境中 240 小時	
3	Humidity test 相對濕度測試	After being placed in a chamber at +40 and 90 $\pm 5\%$ relative humidity for 240 hours 置於+40 , 相對濕度 90 $\pm 5\%$ 環境中 240 小時	
4	Temp. cycle test 溫度循環測試	The part shall be subjected to 5 cycles. One cycle shall be consist of: 單體承受溫度循環測試 5 次,其循環內容如圖示: 	

H. RELIABILITY TEST 信賴性測試

No.	Item	Test condition	Evaluation standard
1	Operating life test 壽命測試	1.Continuous life test 高溫壽命測試(連續) 48 hours continuous operation at +45 with rated voltage applied. 在+45 環境下,以額定電壓連續操作 48 小時 2.Intermittent life test 室溫壽命測試(間歇) A duty cycle of 1 minute on, 1 minutes off, a minimum of 5000 times at room temp.(+25 ± 2)and rated voltage applied 在室溫下(+25 ± 2), 以額定電壓操作, 通電 1 分鐘/斷電 1 分鐘,測試 5000 次循環.	Being placed for 4 hours at +25 , buzzer shall be measured. The value of oscillation frequency/ current consumption should be in $\pm 10\%$ compared with initial ones .The SPL should be in $\pm 10\text{dB}$ compared with initial one. 經測試後, 靜置於+25 (室溫) 環境中 4 小時後, 諧振頻率與消耗電流變化量須在 $\pm 10\%$ 內. 輸出音壓變化量須在 $\pm 10\text{dB}$ 內.

TEST CONDITION.

Standard Test Condition 一般測試條件	:	a) Temperature : +5 ~ +35	b) Humidity : 45-85%	c) Pressure : 860-1060mbar
Judgment Test Condition 爭議時測試條件	:	a) Temperature : +25 \pm 2	b) Humidity : 60-70%	c) Pressure : 860-1060mbar

I. PACKING STANDARD 包裝規格

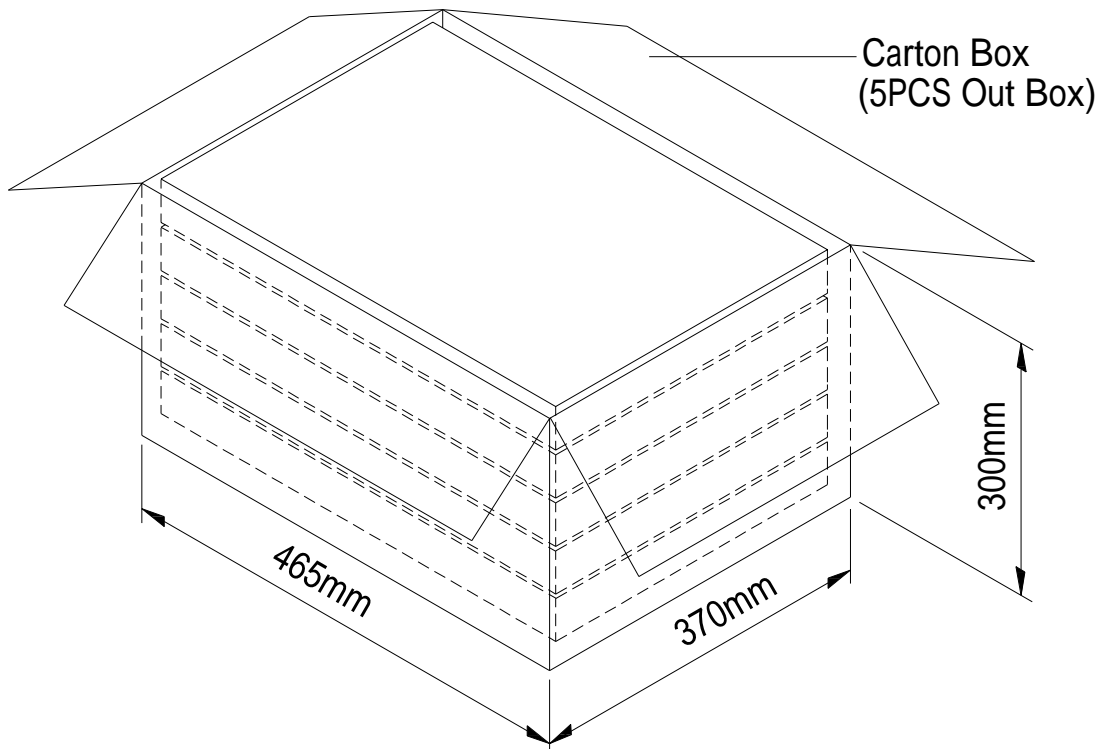
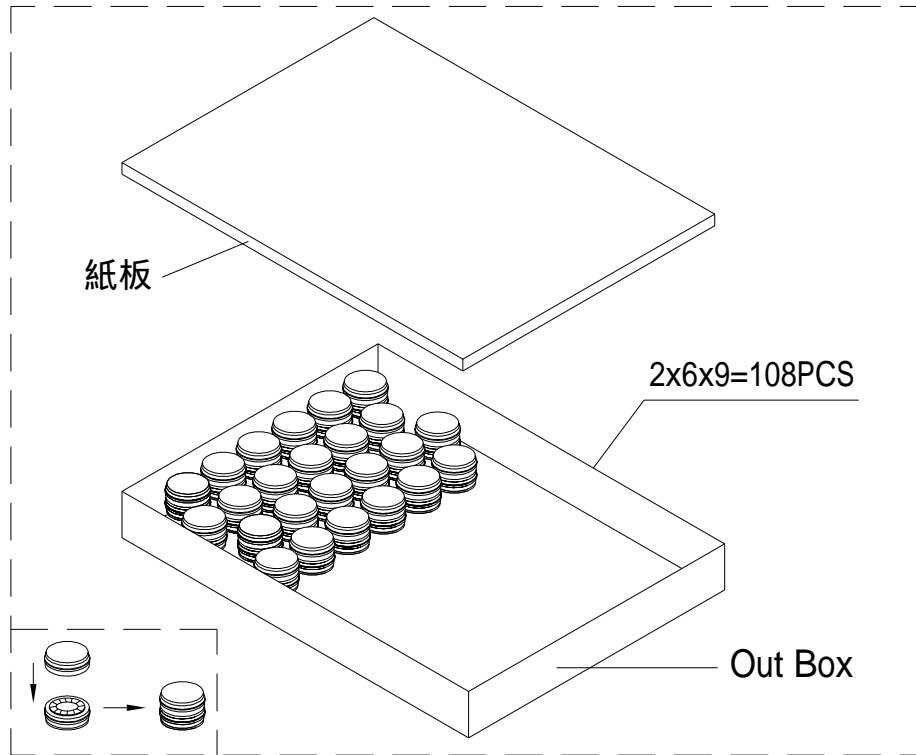

Out Box	450mmx350mmx50mm	1x108PCS=108PCS
Carton Box	455mmx365mmx300mm	108PCSx5=540PCS