

Video Encoder EI3 Extender Board Manual

an EZ-Extender® product

Revision 1.0, May 2012

Part Number
82-000252-01

Analog Devices, Inc.
One Technology Way
Norwood, Mass. 02062-9106



Copyright Information

©2012 Analog Devices, Inc., ALL RIGHTS RESERVED. This document may not be reproduced in any form without prior, express written consent from Analog Devices, Inc.

Printed in the USA.

Disclaimer

Analog Devices, Inc. reserves the right to change this product without prior notice. Information furnished by Analog Devices is believed to be accurate and reliable. However, no responsibility is assumed by Analog Devices for its use; nor for any infringement of patents or other rights of third parties which may result from its use. No license is granted by implication or otherwise under the patent rights of Analog Devices, Inc.

Trademark and Service Mark Notice

The Analog Devices logo, Blackfin, CrossCore, EngineerZone, EZ-Board, EZ-Extender, EZ-KIT Lite, and VisualDSP++ are registered trademarks of Analog Devices, Inc.

All other brand and product names are trademarks or service marks of their respective owners.

Regulatory Compliance

The Video Encoder EI3 Extender Board is designed to be used solely in a laboratory environment. The board is not intended for use as a consumer end product or as a portion of a consumer end product. The board is an open system design which does not include a shielded enclosure and therefore may cause interference to other electrical devices in close proximity. This board should not be used in or near any medical equipment or RF devices.

The Video Encoder EI3 Extender Board is in the process of being certified to comply with the essential requirements of the European EMC directive 89/336/EEC (inclusive 93/68/EEC) and, therefore, carries the “CE” mark.



The extender board contains ESD (electrostatic discharge) sensitive devices. Electrostatic charges readily accumulate on the human body and equipment and can discharge without detection. Permanent damage may occur on devices subjected to high-energy discharges. Proper ESD precautions are recommended to avoid performance degradation or loss of functionality. Store unused extender boards in the protective shipping package.



CONTENTS

PREFACE

Product Overview	ix
Purpose of This Manual	x
Intended Audience	xi
Manual Contents	xi
What's New in This Manual	xii
Technical Support	xii
Supported Products	xiii
Product Information	xiii
Analog Devices Web Site	xiii
EngineerZone	xiv
Related Documents	xv
Notation Conventions	xv

USING VIDEO ENCODER EI3 EXTENDER BOARD

Package Contents	1-2
Supported Operating Systems	1-2
System Requirements	1-3
Video Encoder EI3 Extender Board Installation	1-3

Contents

High Performance HDMI Transmitter (ADV7511)	1-4
Multi-Format Video Encoder (ADV7431)	1-5
Expansion Interface III	1-6
Example Programs	1-7
Board Design Database	1-8

VIDEO ENCODER EI3 EXTENDER BOARD HARDWARE REFERENCE

System Architecture	2-2
Software-Controlled Switches (SoftConfig)	2-3
Overview of SoftConfig	2-3
Programming SoftConfig	2-7
Video Encoder Mode Select	2-10
ADV7511_INT_GPIOx Signal	2-10
27MHZ_CLK_EN Signal	2-10
74MHZ_CLK_EN Signal	2-10
SPORT_ENABLE Signal	2-10
Connectors	2-11
Expansion III (EI3) Connectors (J4)	2-12
S-Video Connector (J2)	2-12
Component Connector (J14)	2-13
HDMI Connector (J5)	2-13
Composite Connector (J6)	2-14
Power Connector (P1)	2-14

LEDs	2-15
HDMI Detect LED (LED1)	2-15
Power LED (LED2)	2-15

VIDEO ENCODER EI3 EXTENDER BOARD BILL OF MATERIALS

VIDEO ENCODER EI3 EXTENDER BOARD SCHEMATIC

Title Page	B-1
EI3 Connector/GPIO Extender	B-2
Voltage Translators	B-3
Video Modes	B-4
ADV7511	B-5
ADV7341	B-6
Video Connectors	B-7
Power	B-8

INDEX

Contents

PREFACE

Thank you for purchasing the Video Encoder EI3 Extender Board, an EZ-Extender[®] product for EZ-KIT Lite[®]/EZ-Board[®] evaluation systems with the expansion interface 3 (EI3).

The EZ-KIT Lite/EZ-Board and Video Encoder EI3 Extender Board are designed to be used in conjunction with the CrossCore[®] Embedded Studio (CCES) development environment.

To learn more about Analog Devices development software, go to <http://www.analog.com/processors/tools>.

Product Overview

The Video Encoder EI3 Extender Board is a separately sold daughter board that plugs onto the expansion interface 3 (EI3) of an EZ-KIT Lite/EZ-Board evaluation system. The extender board aids the design and prototyping phases of embedded processor-targeted applications.

The board extends the capabilities of the evaluation system by providing a connection between the parallel peripheral interface (PPI) of the processor and the ADV7511 and ADV7341 video encoders. The SPORT is used for transmitting audio data. The two-wire interface (TWI) port of the processor is used to communicate to the video encoders and SoftConfig on the extender.

Purpose of This Manual

The following is a list of the Video Encoder EI3 Extender Board interfaces.

- Video interface
 - ADV7511 — 225 MHz, high performance HDMI transmitter with ARC
 - ADV7341— multi-format video encoder, six 12-bit noise-shaped video DACs
- Video connectors
 - One HDMI
 - One SVIDEO
 - One Component
 - One Composite
- No power supply required: derives power from the EZ-KIT Lite/EZ-Board
- CE certified
- Traditional mechanical switches and jumpers for changing the board's factory setup have been removed in favor of I²C-controlled software switches.

Purpose of This Manual

The *Video Encoder EI3 Extender Board Manual* provides instructions for installing the product hardware (board). The text describes operation and configuration of the board components and provides guidelines for running your own code on the Video Encoder EI3 Extender Board. Finally, a schematic and a bill of materials are provided for reference.

Intended Audience

The primary audience for this manual is a programmer who is familiar with Analog Devices processors. This manual assumes that the audience has a working knowledge of the appropriate processor architecture, instruction set, and C/C++ programming languages.

Programmers who are unfamiliar with Analog Devices processors can use this manual, but should supplement it with other texts that describe your target architecture and hardware development tools.

Programmers who are unfamiliar with the CrossCore Embedded Studio programming environment or the mating evaluation board, should refer to the CCES online help.

Manual Contents

The manual consists of:

- Chapter 1, [“Using Video Encoder EI3 Extender Board” on page 1-1](#)
Provides basic board information.
- Chapter 2, [“Video Encoder EI3 Extender Board Hardware Reference” on page 2-1](#)
Provides information about the product’s hardware components.
- Appendix A, [“Video Encoder EI3 Extender Board Bill Of Materials” on page A-1](#)
Provides a list of hardware components used to manufacture the extender board.
- Appendix B, [“Video Encoder EI3 Extender Board Schematic” on page B-1](#)
Provides all circuits on the extender board.

What's New in This Manual

This is the first revision of the *Video Encoder EI3 Extender Board Manual*.

Technical Support

You can reach Analog Devices processors and DSP technical support in the following ways:

- Post your questions in the processors and DSP support community at EngineerZone[®]:
<http://ez.analog.com/community/dsp>
- Submit your questions to technical support directly at:
<http://www.analog.com/support>
- E-mail your questions about processors, DSPs, and tools development software from **CrossCore Embedded Studio** or **VisualDSP++[®]**:

Choose **Help > Email Support**. This creates an e-mail to processor.tools.support@analog.com and automatically attaches your **CrossCore Embedded Studio** or **VisualDSP++** version information and `license.dat` file.

- E-mail your questions about processors and processor applications to:
processor.support@analog.com or
processor.china@analog.com (Greater China support)
- In the **USA only**, call 1-800-ANALOGD (1-800-262-5643)

- Contact your Analog Devices sales office or authorized distributor.
Locate one at:
www.analog.com/adi-sales
- Send questions by mail to:
Processors and DSP Technical Support
Analog Devices, Inc.
Three Technology Way
P.O. Box 9106
Norwood, MA 02062-9106
USA

Supported Products

This extender board supports EZ-KIT Lite/EZ-Board evaluation systems with the expansion interface 3.

Product Information

Product information can be obtained from the Analog Devices Web site and the CCES online help system.

Analog Devices Web Site

The Analog Devices Web site, www.analog.com, provides information about a broad range of products— analog integrated circuits, amplifiers, converters, and digital signal processors.

To access a complete technical library for each processor family, go to http://www.analog.com/processors/technical_library. The manuals selection opens a list of current manuals related to the product as well as a link to the previous revisions of the manuals. When locating your manual

Product Information

title, note a possible errata check mark next to the title that leads to the current correction report against the manual.

Also note, myAnalog.com is a free feature of the Analog Devices Web site that allows customization of a Web page to display only the latest information about products you are interested in. You can choose to receive weekly e-mail notifications containing updates to the Web pages that meet your interests, including documentation errata against all manuals. myAnalog.com provides access to books, application notes, data sheets, code examples, and more.

Visit myAnalog.com (found on the Analog Devices home page) to sign up. If you are a registered user, just log on. Your user name is your e-mail address.

EngineerZone

EngineerZone is a technical support forum from Analog Devices. It allows you direct access to ADI technical support engineers. You can search FAQs and technical information to get quick answers to your embedded processing and DSP design questions.

Use EngineerZone to connect with other DSP developers who face similar design challenges. You can also use this open forum to share knowledge and collaborate with the ADI support team and your peers. Visit <http://ez.analog.com> to sign up.

Related Documents

For additional information about the product, refer to the following publications.

Table 1. Related Processor Publications



Title	Description
<i>Processor Data Sheet</i>	General functional description, pinout, and timing of the processor
<i>Processor Hardware Reference</i>	Description of the internal processor architecture and all register functions
<i>Blackfin® Processor Programming Reference</i>	Description of all allowed processor assembly instructions

Notation Conventions

Text conventions used in this manual are identified and described as follows. Additional conventions, which apply only to specific chapters, may appear throughout this document.

Example	Description
Close command (File menu)	Titles in reference sections indicate the location of an item within the CCES environment's menu system (for example, the Close command appears on the File menu).
{this that}	Alternative required items in syntax descriptions appear within curly brackets and separated by vertical bars; read the example as <i>this</i> or <i>that</i> . One or the other is required.
[this that]	Optional items in syntax descriptions appear within brackets and separated by vertical bars; read the example as an optional <i>this</i> or <i>that</i> .
[this,...]	Optional item lists in syntax descriptions appear within brackets delimited by commas and terminated with an ellipsis; read the example as an optional comma-separated list of <i>this</i> .

Notation Conventions

Example	Description
.SECTION	Commands, directives, keywords, and feature names are in text with letter gothic font.
<i>filename</i>	Non-keyword placeholders appear in text with italic style format.
	Note: For correct operation, ... A Note provides supplementary information on a related topic. In the online version of this book, the word Note appears instead of this symbol.
	Caution: Incorrect device operation may result if ... Caution: Device damage may result if ... A Caution identifies conditions or inappropriate usage of the product that could lead to undesirable results or product damage. In the online version of this book, the word Caution appears instead of this symbol.
	Warning: Injury to device users may result if ... A Warning identifies conditions or inappropriate usage of the product that could lead to conditions that are potentially hazardous for the devices users. In the online version of this book, the word Warning appears instead of this symbol.

1 USING VIDEO ENCODER EI3 EXTENDER BOARD

This chapter provides the setup procedure for the Video Encoder EI3 Extender Board and describes the interfaces the extender supports.

The information is presented in the following order.

- “Package Contents” on page 1-2
- “Supported Operating Systems” on page 1-2
- “System Requirements” on page 1-3
- “Video Encoder EI3 Extender Board Installation” on page 1-3
- “High Performance HDMI Transmitter (ADV7511)” on page 1-4
- “Multi-Format Video Encoder (ADV7431)” on page 1-5
- “Expansion Interface III” on page 1-6
- “Example Programs” on page 1-7
- “Board Design Database” on page 1-8

Package Contents

Your Video Encoder EI3 Extender Board package contains the following items.

- Video Encoder EI3 Extender Board
- A bag containing hardware for securing the extender board on the EZ-KIT Lite/EZ-Board
- Video cables – one HDMI and one component
- Release note containing information about the product download

Contact the vendor where you purchased your extender board or contact Analog Devices, Inc. if any item is missing.

Supported Operating Systems

CCES is supported on the following operating systems:

- Windows[®] XP Professional SP3 (32-bit only)
- Windows Vista[™] Business, Enterprise, or Ultimate SP2 (32-bit only)
- Windows 7 Professional, Enterprise, or Ultimate (32- and 64-bit)



Windows Vista and Windows 7 users may experience User Access Control (UAC) related errors if the software is installed into a protected location, such as Program Files or Program Files (x86). We recommend installing the software in a non-UAC-protected location.

System Requirements

Verify that your PC has these minimum requirements for the CCSE installation:

- 2 GHz single-core processor
- 1 GB RAM
- 8 GB available disk space
- One open USB port



A faster disk drive decreases the build time, especially for a large amount of source files .

Video Encoder EI3 Extender Board Installation

Follow these instructions to ensure correct operation of the product hardware and software.

1. Attach the extender board to the EZ-KIT Lite/EZ-Board.

The J1 connector on the extender board can be connected to the P1A, P2A, or P3A connector on the EZ-KIT Lite/EZ-Board. Refer to the example program for a reference to the proper connector

2. Use the provided hardware to secure the extender to the EZ-KIT Lite/EZ-Board. See [Figure 1-1](#).
3. Refer to the EZ-KIT Lite/EZ-Board manual for information on connecting to a personal computer (PC) and running CCES.

High Performance HDMI Transmitter (ADV7511)

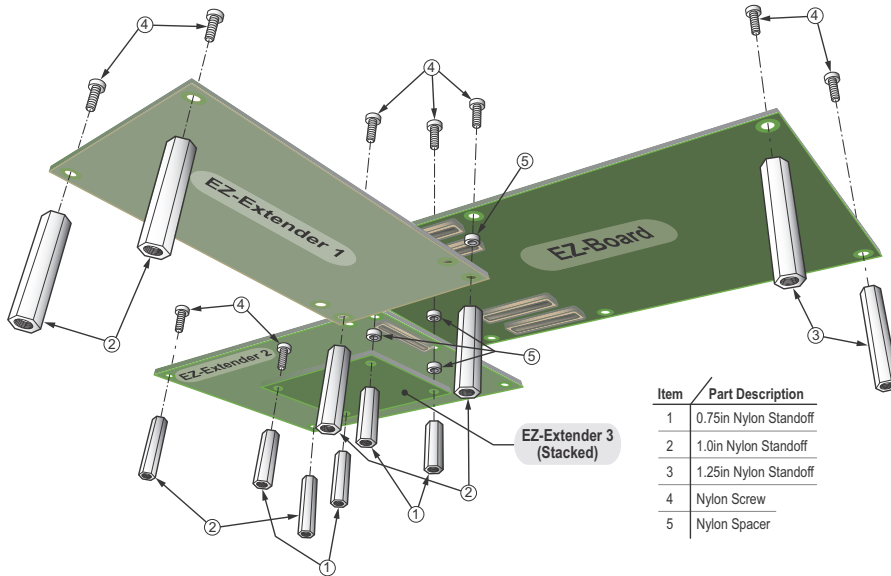

Figure 1-1. Assembled Board Diagram

High Performance HDMI Transmitter (ADV7511)

The ADV7511 is a 225 MHz high-definition multimedia interface (HDMI) transmitter, which is ideal for home entertainment products including DVD players/receivers, digital set top boxes, A/V receivers, gaming consoles and PCs.

The digital video interface contains an HDMI v1.4 and a DVI v1.0 compatible transmitter and supports all HDTV formats (including 1080p with 12-bit Deep Color). The ADV7511 supports the HDMI v1.4 specific features, HEAC (ARC), and 3D video. In addition, the ADV7511

supports x.v.Color, high bit rate audio and programmable AVI Info Frames features. With the inclusion of HDCP, the ADV7511 allows the secure transmission of protected content as specified by the HDCP v1.4 protocol.

The ADV7511 high-performance HDMI transmitter with ARC connects to the PPI, SPORT, TWI and GPIO of the processor. This device supports up to 1080p.

The ADV7511 can be configured to generate an interrupt based on various events. The TWI port is used for communication between the transmitter and processor. The PPI is used for transmitting video data. The SPORT is used for transmitting audio data. An interrupt signal from the transmitter is connected to a GPIO signal on the processor. The GPIO signal is configured via a software switch. Refer to “[Software-Controlled Switches \(SoftConfig\)](#)” on page 2-3 for more information.

For more information about the ADV7511, go to www.analog.com and search for ADV7511.

An example program demonstrating capabilities of the ADV7511 is available by installing the Video Encoder EI3 Extender Board Support Package (BSP).

Multi-Format Video Encoder (ADV7431)

The ADV7341 is a high speed, digital-to-analog video encoder. Six high speed, NSV, 3.3V, 12-bit video DACs provide support for composite (CVBS), S-Video (Y-C), and component (YPrPb/RGB) analog outputs in standard definition (SD), enhanced definition (ED), or high definition (HD) video formats.

The ADV7341 has a 30-bit pixel input port that can be configured in a variety of ways. SD video formats are supported over an SDR interface

Expansion Interface III

and ED/HD video formats are supported over SDR and DDR interfaces. Pixel data can be supplied in either the YCrCb or RGB color space.

The part also supports embedded EAV/SAV timing codes, external video synchronization signals, and I²C communication protocol.

In addition, simultaneous SD and ED/HD input and output are supported. Full-drive DACs ensure that external output buffering is not required, while 216 MHz (SD and ED) and 297 MHz (HD) oversampling ensures that external output filtering is not required.

The ADV7341 multi-format video encoder connects to the PPI and TWI of the processor. This device supports up to 1080i/720p.

The TWI port is used for communications between the encoder and processor. The PPI is used for transmitting video data. Refer to [“Software-Controlled Switches \(SoftConfig\)” on page 2-3](#) for more information.

For more information about the ADV7341, go to www.analog.com and search for ADV7341.

An example program demonstrating capabilities of the ADV7341 is available by installing the Video Encoder EI3 Extender Board Support Package (BSP).

Expansion Interface III

The Expansion Interface III (EI3) allows an extender board to be tested across various hardware platforms that have the same expansion interface connectors.

The EI3 implemented on the Video Encoder EI3 Expander Board contains the PPI, SPORT, TWI and GPIO ports. These signals are used for the peripherals on the extender. For pinout information, go to [Appendix B, “Video Encoder EI3 Extender Board Schematic”](#). The

Using Video Encoder EI3 Extender Board

mechanical dimensions of the expansion connectors can be obtained by contacting “[Technical Support](#)”.

The Video Encoder EI3 Extender Board supports interfacing with EZ-Boards which are operating at an IO voltage of 3.3V. Other IO voltages are not supported.

The Video Encoder EI3 Extender Board supports being powered from either the EZ-Board or through the on board 5V power connector (P1).

For more information about other daughter boards, visit the Analog Devices Web site.

Limits to current and interface speed must be taken into consideration when using the EI3. Current for the EI3 can be sourced from the EZ-KIT Lite/EZ-Board; therefore, the current should be limited to 200 mA for 5V and 300 mA for the 3.3V planes. If more current is required, then a separate power connector and a regulator must be designed on the daughter card. Additional circuitry can add extra loading to signals, decreasing their maximum effective speed.



Analog Devices does not support and is not responsible for the effects of additional circuitry.

Example Programs

Example programs are included with the Video Encoder EI3 Extender Board Support Package (BSP). Example programs demonstrate various capabilities of the product. The support package is installed on top of CrossCore Embedded Studio. Once installed, the example programs can be found in the following directory:

```
<install_path>\Video_Encoder_EI3_Extender_Board-RelX.X.X\Video_Encoder_EI3
```

where *X.X.X* denotes the support package release number.

Board Design Database

A .zip file containing all of the electronic information required for the design, layout, fabrication, and assembly of the product is available for download from the Analog Devices board design database at:

<http://www.analog.com/en/processors-dsp/blackfin/processors/board-design-database/resources/index.html>.

2 VIDEO ENCODER EI3 EXTENDER BOARD HARDWARE REFERENCE

This chapter describes the hardware design of the Video Encoder EI3 Extender Board.

The following topics are covered.

- [“System Architecture” on page 2-2](#)
Describes the daughter board configuration and explains how the board components interface with the processor and EZ-KIT Lite.
- [“Software-Controlled Switches \(SoftConfig\)” on page 2-3](#)
Lists and describes the software-controlled switches.
- [“Connectors” on page 2-11](#)
Shows the locations and provides part numbers for the on-board connectors. In addition, the manufacturer and part number information is provided for the mating parts.
- [“LEDs” on page 2-15](#)
Describes the on-board LEDs.

System Architecture

A block diagram of the Video Encoder EI3 Extender Board is shown in Figure 2-1.

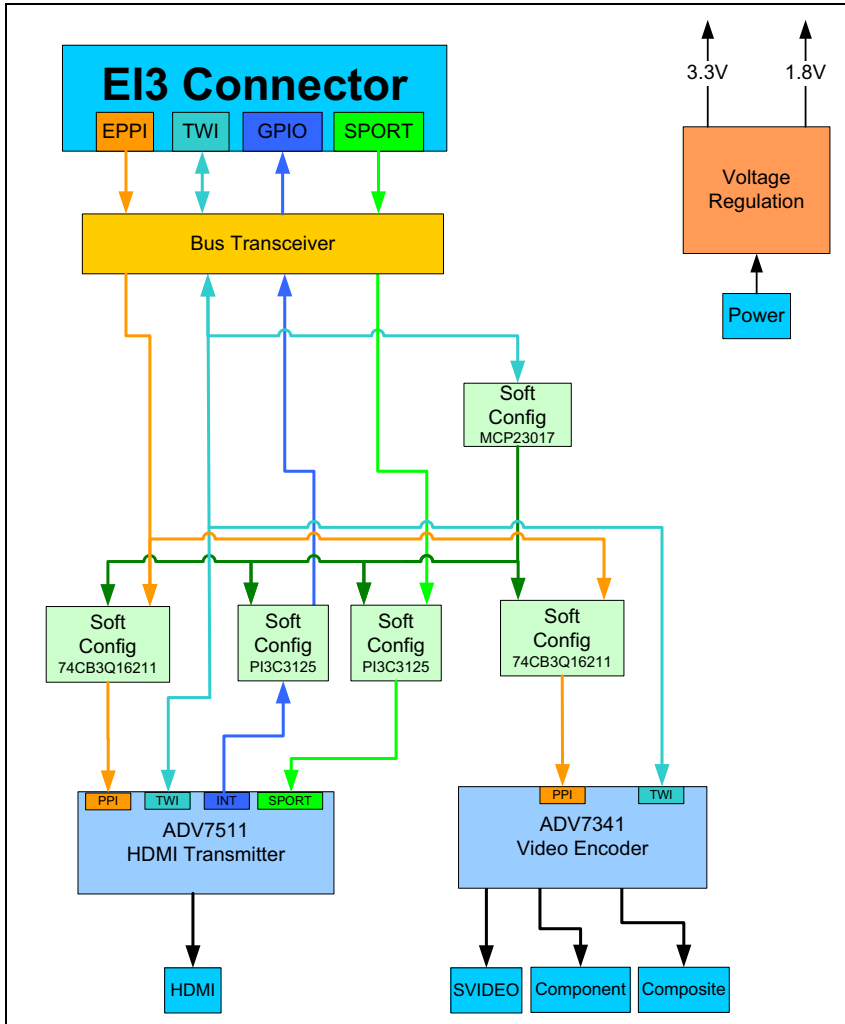



Figure 2-1. Video Encoder EI3 Extender Board Block Diagram

Software-Controlled Switches (SoftConfig)

On the Video Encoder EI3 Extender Board, all of the traditional mechanical switches/jumpers have been replaced by I²C software-controlled switches. Refer to any `SoftConfig*.c` file found in the installation directory of CCES for an example of how to set up the SoftConfig feature of the product through software.

The SoftConfig section of this manual serves as a reference to any user that intends to modify an existing software example. If software provided by ADI is used, there should be little need to reference this section.

 Care should be taken when changing SoftConfig settings not to create a conflict with interfaces. The same GPIO signal and SPICS should not be configured for more than one interface.

Overview of SoftConfig

In order to further clarify the use of electronic single FET switches and multi-channel bus switches, an example of each is illustrated and compared to a traditional mechanical switching solution. This is a generic example. After this generic discussion there is a detailed explanation of the SoftConfig interface specific to the extender.

[Figure 2-2](#) shows two individual FET switches (Pericom PI3A125CEX) with reference designators UA and UB. Net names `ENABLE_A` and `ENABLE_B` control UA and UB. The default FET switch enable settings in this example are controlled by resistors RA and RB which pull the enable pin 1 of UA and UB to ground (low). In a real example, these enable signals are controlled by the Microchip IO expander. The default pull-down resistors connect the signals `EXAMPLE_SIGNAL_A` and `EXAMPLE_SIGNAL_B` and also connect signals `EXAMPLE_SIGNAL_C` and `EXAMPLE_SIGNAL_D`. To disconnect `EXAMPLE_SIGNAL_A` from `EXAMPLE_SIGNAL_B`, the Microchip IO expander is

Software-Controlled Switches (SoftConfig)

used to change `ENABLE_A` to a logic 1 through software that interfaces with the Microchip. The same procedure for `ENABLE_B` would disconnect `EXAMPLE_SIGNAL_C` from `EXAMPLE_SIGNAL_D`.

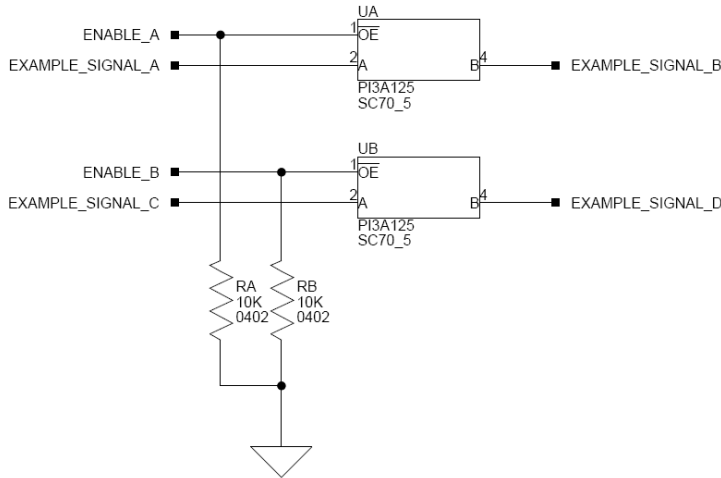

Figure 2-2. Example of Individual FET Switches

Figure 2-3 shows the equivalent circuit to Figure 2-2 but utilizes mechanical switches that are in the same package. The default is shown by black boxes located closer to the ON label of the switches. In order to disconnect these switches, physically move the switch to the OFF position.

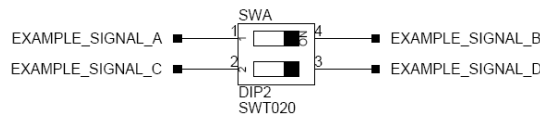

Figure 2-3. Example of Mechanical Switch Equivalent to Figure 2-2

Video Encoder EI3 Extender Board Hardware Reference

Figure 2-4 shows a bus switch example, reference designator UC (Pericom PI3LVD512ZHE), selecting between lettered functionality and numbered functionality. The signals on the left side are multiplexed signals with naming convention letter_number. The signals on the right side are separated into letter and number, with the number on the lower group (eg. 0B1) and the letter on the upper group (eg. 0B2). The default setting is controlled by the signal CONTROL_LETTER_NUMBER which is pulled low. This selects the number signals on the right to be connected to the multiplexed signals on the left by

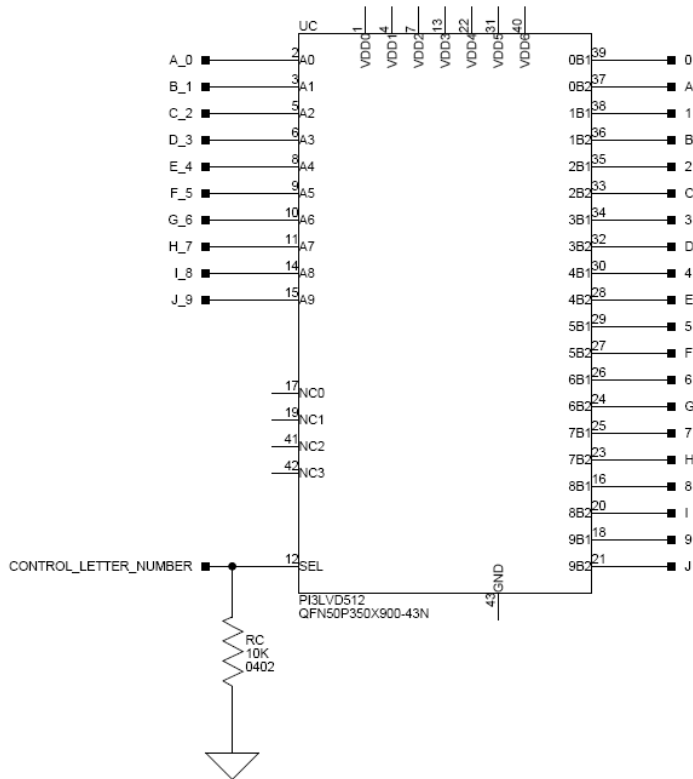

Figure 2-4. Example of Bus Switch

The right side of the circuit shows the signals separated into letter and number, with the number on the lower group (eg. 0B1) and the letter on the upper group (eg. 0B2). The default setting is controlled by the signal CONTROL_LETTER_NUMBER which is pulled low. This selects the number signals on the right to be connected to the multiplexed signals on the left by

Software-Controlled Switches (SoftConfig)

default. In this example, the Microchip IO expander is not shown but controls the signal `CONTROL_LETTER_NUMBER` and allows the user to change the selection through software.

Figure 2-5 shows the equivalent circuit to Figure 2-4 but utilizes mechanical switches. Notice the default for reference designators `SWC` and `SWD` is illustrated by black boxes located closer to the `ON` label of the switches to enable the number signals by default. Note the default setting for reference designators `SWE` and `SWF` is `OFF`. In order to connect the letters instead of the numbers, the user physically changes all switches on `SWC` and `SWD` to the `OFF` position and all switches on `SWE` and `SWF` to the `ON` position.

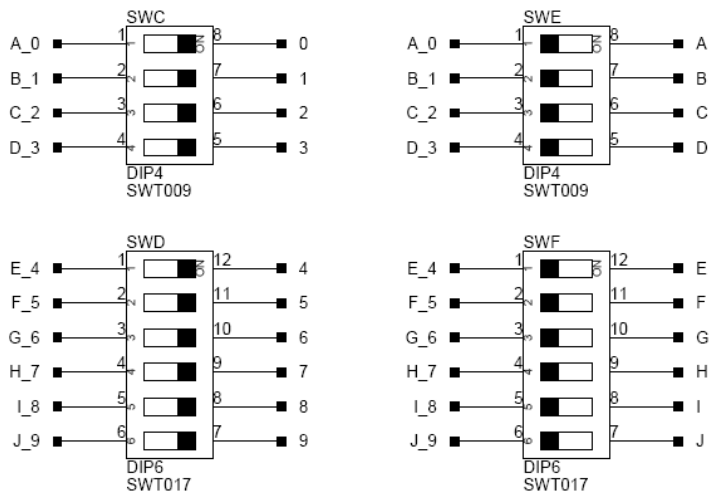

Figure 2-5. Example of Mechanical Switch Equivalent to Figure 2-4

Programming SoftConfig

On the Video Encoder EI3 Extender Board, a single Microchip MCP23017 device controls individual and electronic bus switches via TWI. The device has the following programming characteristics:

- There are two programmable GPIO registers.

GPIO Register	Register Address
GPIOA	0x12
GPIOB	0x13

- Each GPIO register controls eight signals (software switches).
- By default, the GPIO signals function as input signals; therefore, all electronic switches are in the OFF state.

The signals must be programmed as output signals to override their default values. The following table shows the Microchip register addresses and values that must be written to them to program the signals as output signals.

IODIR Register	IODIR Register Address	Value to be Written to Program Signals as Outputs
IODIRA	0x00	0
IODIRB	0x01	0

Software-Controlled Switches (SoftConfig)

Each example in Cross Core Embedded Studio includes source files that program the soft switches, even if the default settings are being used. The README for each example identifies only the signals that are being changed from their default values. The code that programs the soft switches is located in two files:

- `SoftConfig_Encoder.c` for configuring the extender board
- `SoftConfig_xxx.c` for configuring the EZ-KIT Lite/EZ-Board; `xxx` identifies the EZ-KIT Lite/EZ-Board file in each example.

Page 2 of [Appendix B, “Video Encoder EI3 Extender Board Schematic”](#) shows how the GPIO signals are connected to the board’s ICs.

U13 and U10-U13 are 24-bit bus switches. They are used to select how the transmitter/encoder is connected to the processor. You can select an 8-bit, 16-bit, or 24-bit interface.

U8-U9 are 2-port bus switches. They are used for selecting which GPIO signals to use as the interrupt.

U18 is an 8-port bus switch. It is used to connect/disconnect the SPORT to the ADV7511.

[Table 2-1](#) and [Table 2-2](#) show the output signals of the GPIO expander (U10) with a TWI address of 0100 101X, where X represents the read or write bit. The signals that control an individual FET have an entry under the **FET** column. The **Component Connected** column shows the board IC that is connected if the FET is enabled.

Video Encoder EI3 Extender Board Hardware Reference

Table 2-1. Output Signals of GPIO Expander (U19 Port A)

Bit	Signal Name	Description	FET	Component Connected	Default
0	$\overline{24_BIT_ADV7511}$	24-bit video mode	U10	U14	Off
1	$\overline{24_BIT_ADV7341}$	24-bit video mode	U11	U2	Off
2	$\overline{16_BIT_ADV7511}$	16-bit video mode	U13	U14	Off
3	$\overline{16_BIT_ADV7341}$	16-bit video mode	U12	U2	Off
4	$\overline{27MHZ_CLK_EN}$	Enable 27 MHz oscillator		U15	Off
5	$\overline{74MHZ_CLK_EN}$	Enable 74 MHz oscillator		U14	Off
6	$\overline{8_BIT_ADV7341}$	8-bit video mode	U3	U2	Off
7	SPORT_ENABLE	Enable SPORT interface	U18	U14	Off

Table 2-2. Output Signals of GPIO Expander (U19 Port B)

Bit	Signal Name	Description	FET	Component Connected	Default
0	$\overline{ADV7511_INT_GPIO0}$	Transmitter interrupt	U9	U14	Off
1	$\overline{ADV7511_INT_GPIO1}$	Transmitter interrupt	U9	U14	Off
2	$\overline{ADV7511_INT_GPIO2}$	Transmitter interrupt	U19	U14	Off
3	$\overline{ADV7511_INT_GPIO3}$	Transmitter interrupt	U9	U14	Off
4	$\overline{ADV7511_INT_GPIO4}$	Transmitter interrupt	U8	U14	Off
5	$\overline{ADV7511_INT_GPIO5}$	Transmitter interrupt	U8	U14	Off
6	$\overline{ADV7511_INT_GPIO6}$	Transmitter interrupt	U8	U14	Off
7	$\overline{ADV7511_INT_GPIO7}$	Transmitter interrupt	U8	U14	Off

Video Encoder Mode Select

The Video Encoder Mode Select determines whether the interface to the processors PPI is 8, 16 or 24 bits. The Video Encoder Mode select is chosen by driving low either the $\overline{24_BIT_ADV7511}$, $\overline{16_BIT_ADV7511}$, $\overline{24_BIT_ADV7341}$, $\overline{16_BIT_ADV7341}$ or $\overline{8_BIT_ADV7341}$ signal (U20 ports GPA0-GPA3, GPA6). Driving one of these signals low enables the appropriate bus switches (U10-U13 and U3).

ADV7511_INT_GPIOX Signal

The $\overline{ADV7511_INT_GPIOx}$ signal connects the interrupt signal of the ADV7511 to one of eight GPIO pins of the processor. U20 ports GPB0-GPB7 are used to select the connection to the appropriate GPIO signal via the U8 and U9 bus switch.

27MHZ_CLK_EN Signal

The $\overline{27MHZ_CLK_EN}$ signal is used to enable the onboard 27 MHz oscillator which connects to the ADV7511 and ADV7341. U20 port GPA4 is used to enable and disable the oscillator. The default is disabled.

74MHZ_CLK_EN Signal

The $\overline{74MHZ_CLK_EN}$ signal is used to enable the onboard 74.25 MHz oscillator which connects to the ADV7511 and ADV7341. U20 port GPA5 is used to enable and disable the oscillator. The default is disabled.

SPORT_ENABLE Signal

The $\overline{SPORT_ENABLE}$ signal connects the audio signal of the ADV7511 to the SPORT interface of the processor. U20 port GPA7 is used to enable or disable the connection via the U18 bus switch. The default is disabled.

Connectors

This section describes connector functionality and provides information about mating connectors. [Figure 2-6](#) shows the locations of all connectors on the Video Encoder EI3 Extender Board.

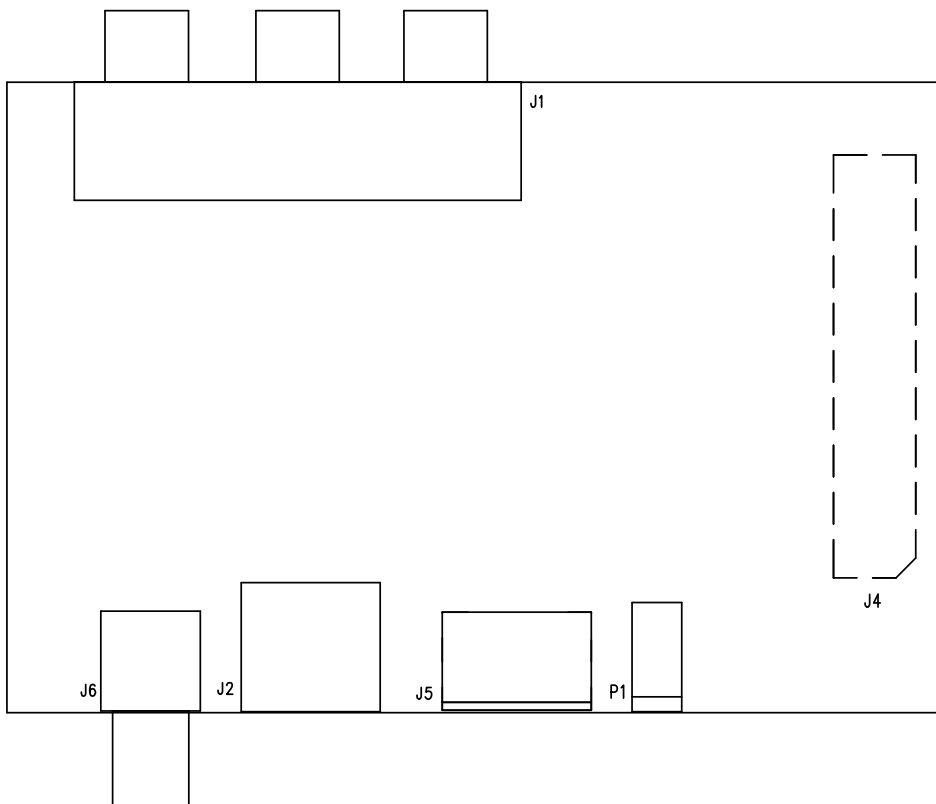

Figure 2-6. Connector Locations

i Connectors denoted by a dotted line are located on the opposite side of the board.

Connectors

Expansion III (EI3) Connectors (J4)

One board-to-board connectors (J4) provide signals from the PPI, SPORT, TWI, and GPIO interfaces of the processor. The connector is located on the bottom side of the board.

Part Description	Manufacturer	Part Number
120-pin, 0.6 mm	HIROSE	FX8-120S-SV(21)
Mating Connector		
120-pin, 0.6 mm	HIROSE	FX8-120P-SV1(91)

S-Video Connector (J2)

The S-Video connector (J2) is a DIN connector which connects to the ADV7341. This connector can be used for Y-C mode and supports SD, ED, and HD video modes.

Part Description	Manufacturer	Part Number
S-Video	CUI	MD-40SM
Mating Cable		
S-Video Cable	Belkin	F8V308-06

Component Connector (J14)

The Component connector (J14) is a group of three RCA jacks which connect to the ADV7341. This connector can be used for YPrPb and RGB modes and supports SD, ED, and HD video modes.

Part Description	Manufacturer	Part Number
Component (3x1 RCA)	CUI	RCJ-32265
Mating Cable		
Component Cable	Belkin	AV21000-06

HDMI Connector (J5)

The HDMI connector (J5) is an HDMI receptacle that is connected to the ADV7511. This connector can be used for YCbCr and RGB modes and supports SD, ED, and HD video modes. It supports ARC and is v.1.4 compliant.

Part Description	Manufacturer	Part Number
HDMI	FCI	10029449-002TLF
Mating Cable		
HDMI Cable	Mediabridge	91-02X-06B

Connectors

Composite Connector (J6)

The Composite connector (J6) is a single RCA jack which connects to the ADV7341. This connector can be used for CVBS and supports SD, ED, and HD video modes.

Part Description	Manufacturer	Part Number
Composite (1 RCA)	Switchcraft	PJ1RAN1X1U01X
Mating Cable		
Composite Cable	Kobiconn	17FH101

Power Connector (P1)

Under normal circumstances the power connector is not needed because the Video Encoder EI3 Extender Board derives its power from the EZ-KIT Lite/EZ-Board. If the EZ-KIT Lite/Video Encoder EI3 Extender Board is not able to supply enough power to the Video Encoder EI3 Extender Board, then an external power supply can be connected to P14 which will power the Video Encoder EI3 Extender Board and EZ-KIT Lite/EZ-Board.

Part Description	Manufacturer	Part Number
0.65 mm power jack	CUI	045-0883R
Mating Cable		
5.0VDC@3.6A power supply	GLOBETEK	GS-1750(R)

LEDs

This section describes the on-board LEDs.

HDMI Detect LED (LED1)

When LED1 is lit solid (yellow), it indicates that an HDMI device has been detected (connected to the HDMI connector (J5)).

Power LED (LED2)

When LED2 is lit solid (green), it indicates that power is being supplied to the board properly.

LEDs

A VIDEO ENCODER EI3 EXTENDER BOARD BILL OF MATERIALS

The bill of materials corresponds to [“Video Encoder EI3 Extender Board Schematic”](#) on page B-1.

Ref.	Qty.	Description	Reference Designator	Manufacturer	Part Number
1	1	SN74LVC1G125 SOT23-5	U22	TI	74LVC1G125DBVRE4
2	2	SN74LVC1G04 SOT23-5	U4-U5	TI	SN74LVC1G04DBVT
3	1	27MHZ OSC003	U15	EPSON	SG-8002CA-MP
4	5	SN74CB3Q16211 TSSOP56	U3,U10-U13	DIGI-KEY	296-17629-1-ND
5	1	SN74AVC4T245 SOIC16	U1	DIGI-KEY	296-17930-1-ND
6	1	SN74AVC8T245 TSSOP24	U18	TI	SN74AVC8T245PW
7	1	12MHZ OSC015	U17	DIGI-KEY	535-9413-2-ND
8	1	MCP23017 QFN65P600X600-29N	U19	DIGI-KEY	MCP23017-E/ML-ND
9	3	PI3C3125 TSSOP14	U7-U9	PERICOM	PI3C3125
10	1	74.25MHZ OSC003	U16	CTS	CB3LV-3I-74M2500
11	1	74AVC24T245 LFBGA84	U6	DIGI-KEY	296-17662-1-ND
12	1	ADV7341BSTZ LQFP64	U2	ADI	ADV7341BSTZ
13	3	ADA4430 SC70_6	U23-U25	ADI	ADA4430-1YKSZ-R2
14	1	ADP1706-1.8V LFCSP8	VR2	ADI	ADP1706ACPZ-1.8-R7
15	1	ADP1706-3.3V LFCSP8	VR1	ADI	ADP1706ACPZ-3.3-R7
16	1	10MA AD1580BRTZ SOT23D	D7	ADI	AD1580BRTZ-R2

Ref.	Qty.	Description	Reference Designator	Manufacturer	Part Number
17	1	ADV7511KSTZ LQFP100	U14	ADI	ADV7511KSTZ
18	1	RCA 1X1 CON012	J6	SWITCH-CRAFT	PJ1RAN1X1U01X
19	1	PWR .65MM CON027	P1	DIGI-KEY	CP1-022PJCT-ND
20	1	1A RESETABLE 1206	F1	RAYCHEM	NANOSMDC110F-2
21	1	HDMI 19P FCI_10029449-002TLF	J5	FCI	10029449-002LF
22	1	RCA 3X1 CUI-STACK_RCJ-32265	J1	DIGI-KEY	CP-1446-ND
23	1	MINI-DIN 4PIN CUI-STACK_MD-40SM	J2	DIGI-KEY	CP-2240-ND
24	1	.6MM 120PIN HIROSE_FX8-120S-SV(21)	J4	HIROSE	FX8-120S-SV(21)
25	1	YELLOW LED001	LED1	DIGI-KEY	P512TR-ND
26	3	10K 1/10W 5% 0805	R5,R7,R9	VISHAY	CRCW080510K0JNEA
27	3	10K 1/10W 5% 0805	R6,R8,R10	VISHAY	CRCW080510K0JNEA
28	2	10K 31MW 5% RNET8	RN1-RN2	CTS	746X101103JP
29	9	10UH 10% 1008	L1-L9	PANASONIC	ELJ-FC100KF
30	9	10UF 6.3V 10% 0805	C22,C49,C58, C66,C68, C84-C85,C92, C95	AVX	08056D106KAT2A

Video Encoder EI3 Extender Board Bill Of Materials

Ref.	Qty.	Description	Reference Designator	Manufacturer	Part Number
31	45	0.1UF 10V 10% 0402	C1-C4,C7-C12, C14-C19,C23, C26,C29-C30, C35-C37,C40, C43-C44,C51, C53-C54,C57, C60-C62,C64, C70,C72-C73, C76-C77,C80, C82,C87,C90, C93,C96	AVX	0402ZD104KAT2A
32	19	0.01UF 16V 10% 0402	C41-C42,C45, C48,C50,C52, C55-C56,C59, C65,C69,C71, C74-C75,C81, C83,C86,C91, C94	AVX	0402YC103KAT2A
33	12	10K 1/16W 5% 0402	R3-R4, R14-R16,R18, R25,R28-R29, R40,R43,R46	VISHAY	CRCW040210K0FKED
34	2	4.7K 1/16W 5% 0402	R30,R38	VISHAY	CRCW04024K70JNED
35	2	0 1/16W 5% 0402	R57-R58	PANASONIC	ERJ-2GE0R00X
36	7	0 1/16W 5% 0402	R11,R13, R26-R27,R49-R 51	PANASONIC	ERJ-2GE0R00X
37	5	33 1/16W 5% 0402	R1-R2,R12, R17,R56	VISHAY	CRCW040233R0JNEA
38	2	2.2UF 10V 10% 0805	C38-C39	AVX	0805ZD225KAT2A
39	4	4.7UF 6.3V 20% 0603	C46-C47,C63, C67	AVX	06036D475MAT2A
40	6	75.0 1/10W 1% 0603	R41-R42, R47-R48, R52-R53	DALE	CRCW060375R0FKEA

Ref.	Qty.	Description	Reference Designator	Manufacturer	Part Number
41	2	1UF 6.3V 20% 0402	C20-C21	PANASONIC	ECJ-0EB0J105M
42	1	GREEN LED001	LED2	PANASONIC	LN1361CTR
43	1	1.1K 1/16W 1% 0402	R37	PANASONIC	ERJ-2RKF1101X
44	2	430 1/16W 1% 0402	R19,R54	DIGI-KEY	311-430LRCT-ND
45	1	VARISTOR V5.5MLA 30A 0603	R55	LITTLE-FUSE	V5.5MLA0603
46	2	0.15UF 10V 10% 0603	C31,C33	AVX	0603ZC154KAT2A
47	3	1A MBR130LSFT1G SOD-123FL	D4-D6	ON SEMI	MBR130LSFT1G
48	1	27K 1/16W 5% 0402	R20	PANASONIC	ERJ-2GEJ273X
49	8	4700PF XXX 2A FIL_NFE61PT	FER1-FER8	DIGI-KEY	490-2554-2-ND
50	1	887 1/10W 1% 0603	R32	DIGI-KEY	311-887HRTR-ND
51	3	5A RCLAMP0524 DIO_RCLAMP0524	D9-D11	SEMTECH	RCLAMP0524P.TCT
52	1	30MA DB3X314 DIO_DB3X314	D8	PANASONIC	DB3X314K0L
53	2	49.9 1/16W 1% 0402	R23-R24	STACKPOLE	RMCF0402FT49R9
54	3	2.0K 1/10W 1% 0402	R21-R22,R31	PANASONIC	ERJ-2RKF2001X
55	1	4.12K 1/10W 1% 0402	R33	PANASONIC	ERJ-2RKF4121X
56	2	0.012UF 10V 10% 0402	C32,C34	DIGI-KEY	399-3009-2-ND
57	2	169.0 1/10W 1% 0402	R35-R36	PANASONIC	ERJ-2RKF1690X
58	1	510.0 1/10W 1% 0402	R34	PANASONIC	ERJ-2RKF5100X
59	3	300.0 1/10W 1% 0402	R39,R44-R45	PANASONIC	ERJ-2RKF3000X
61	3	100MA BAT54S SOT23D	D1-D3	FAIRCHILD	BAT54S

Video Encoder EI3 Extender Board Schematic

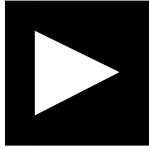
	ANALOG DEVICES	20 Cotton Road Nashua, NH 03063 PH: 1-800-ANALOGD
Title	Video Encoder EI3 Extender Board Title Sheet	
Size C	Board No. A0252-2010	Rev 1.0
Date	3/6/12	Sheet 1 of 8

A

B

C

D

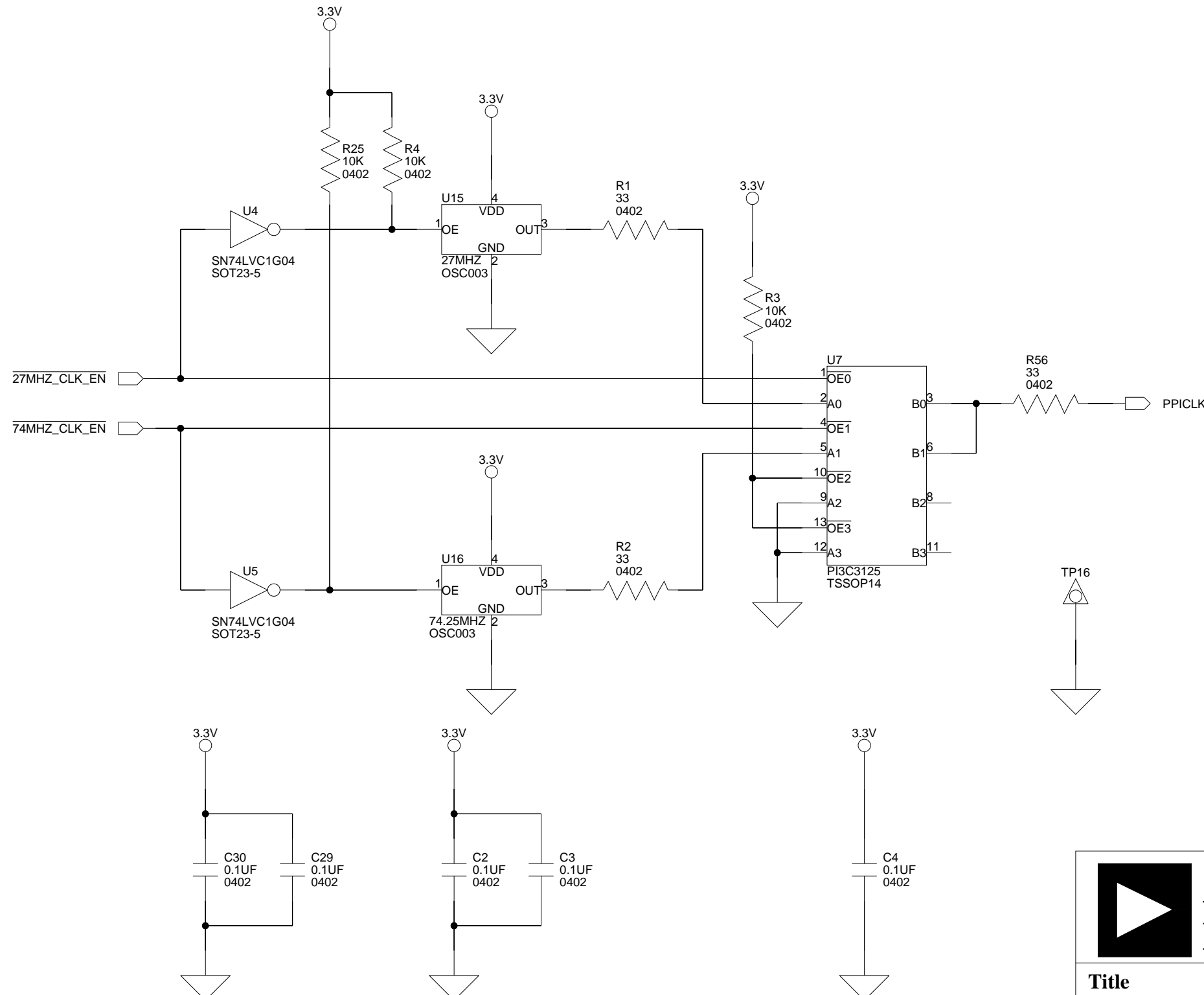
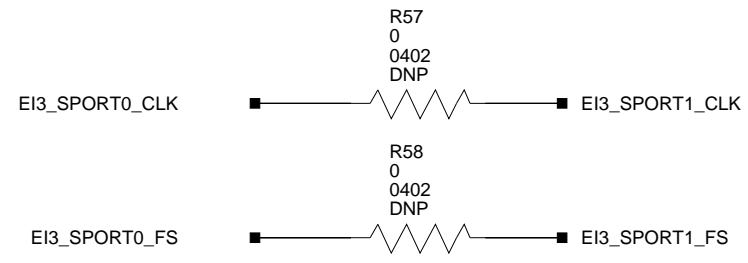
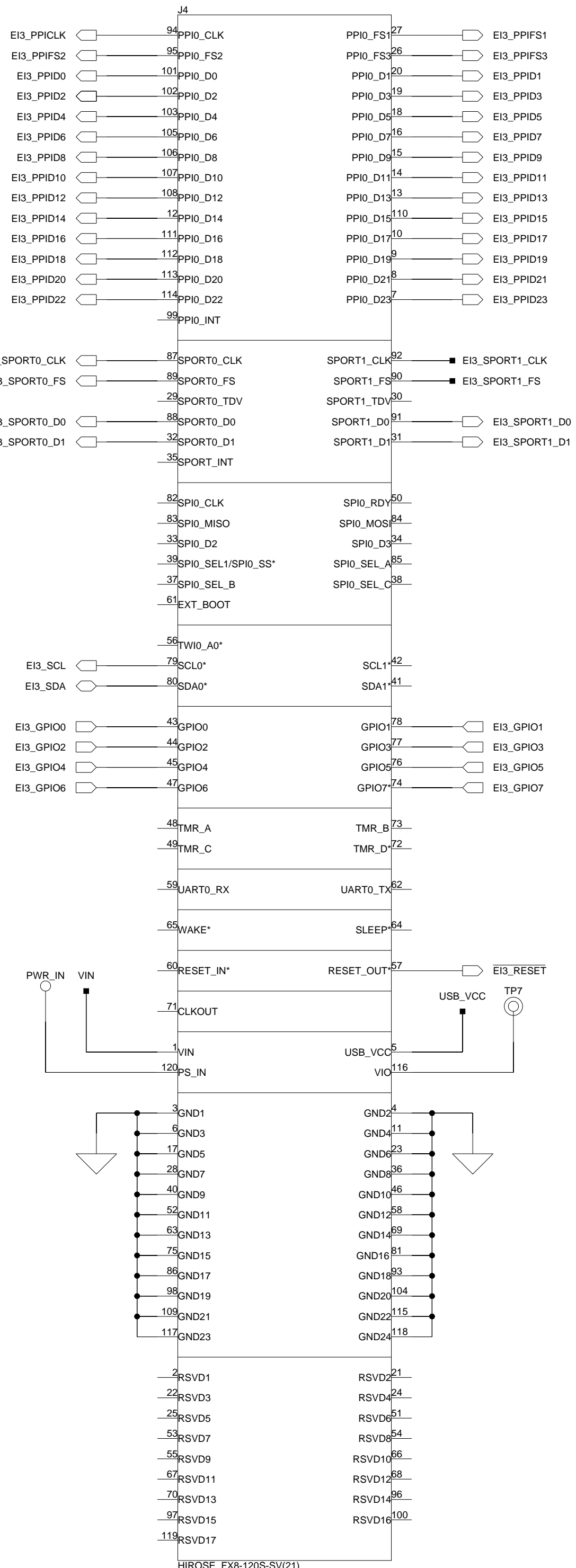

TWI Address 0100 101x
x is the R/W bit. Read - 1, Write - 0

SoftConfig control signals

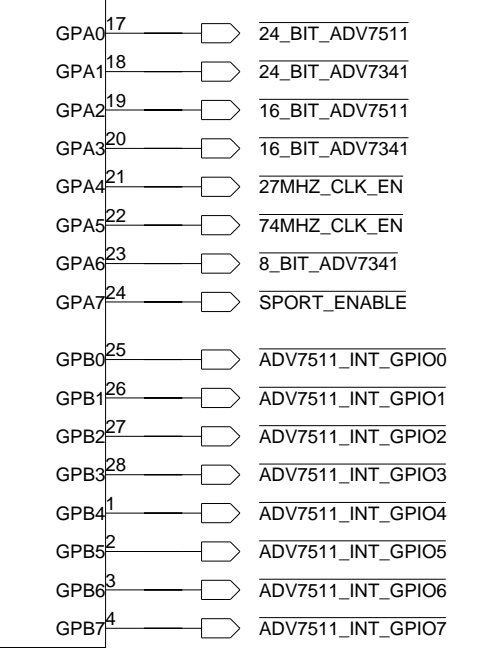
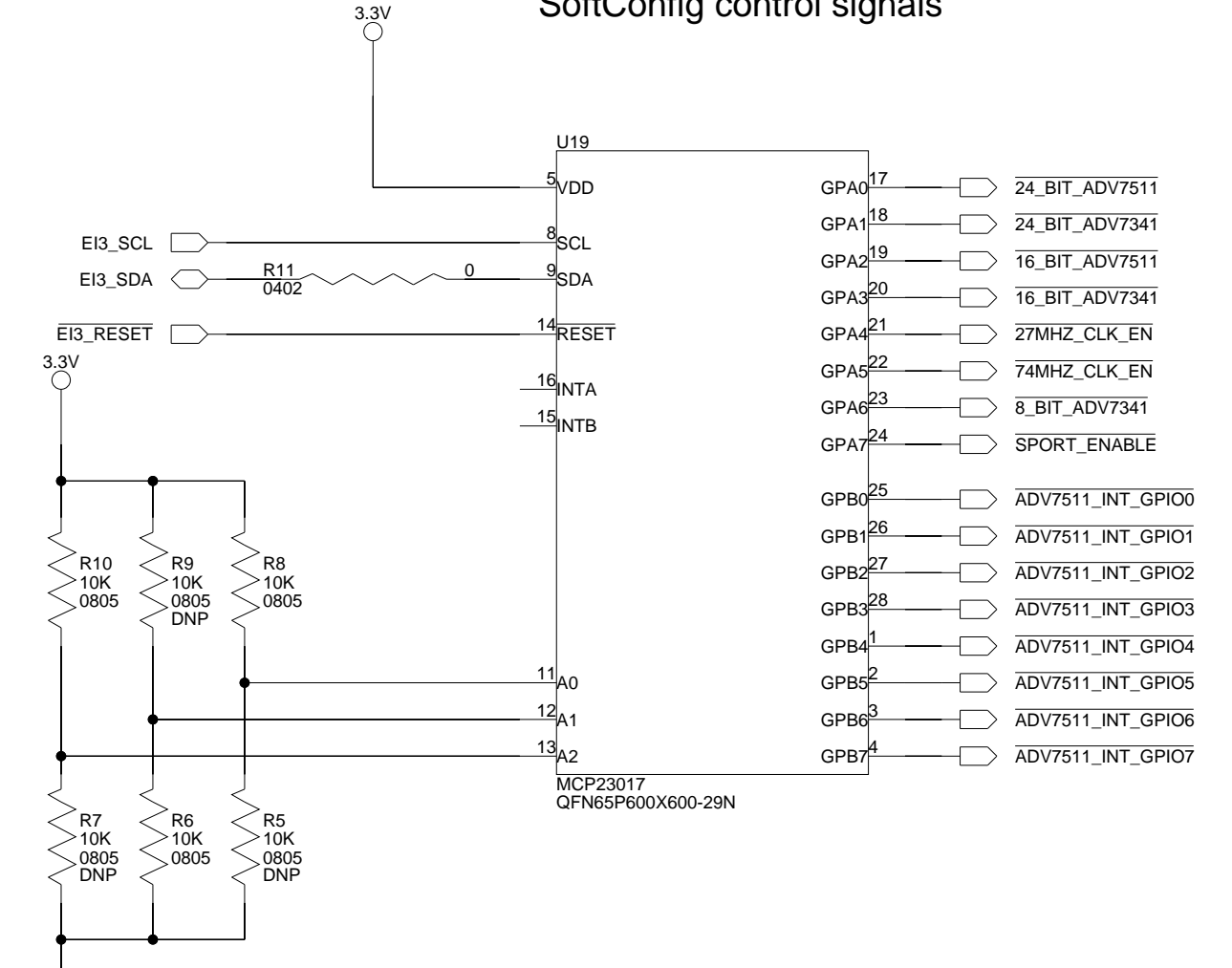

		20 Cotton Road Nashua, NH 03063 PH: 1-800-ANALOGD	
		Title Video Encoder EI3 Extender Board EI3 Connector/GPIO Extender	
Size C	Board No. A0252-2010	Rev 1.0	
Date 3/6/12	Sheet 2 of 8		

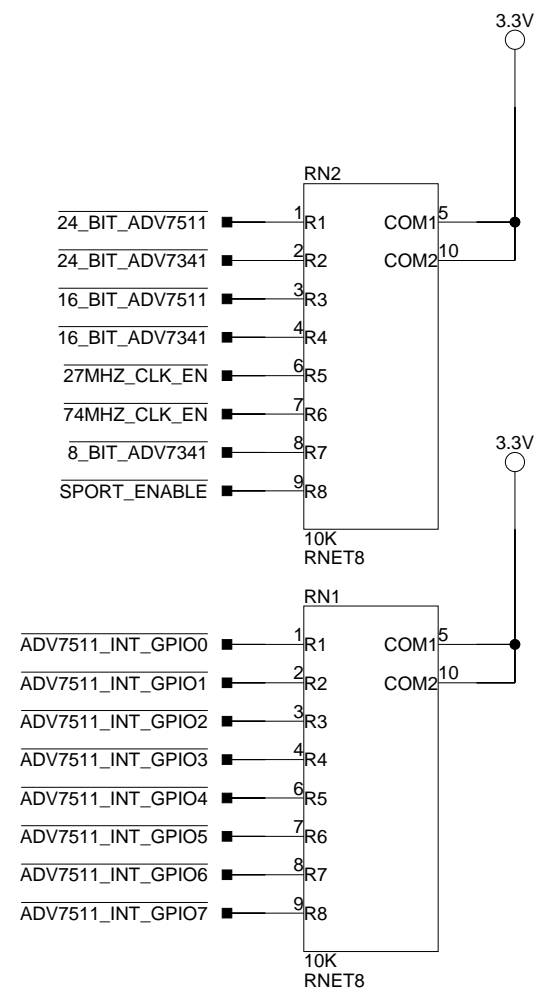
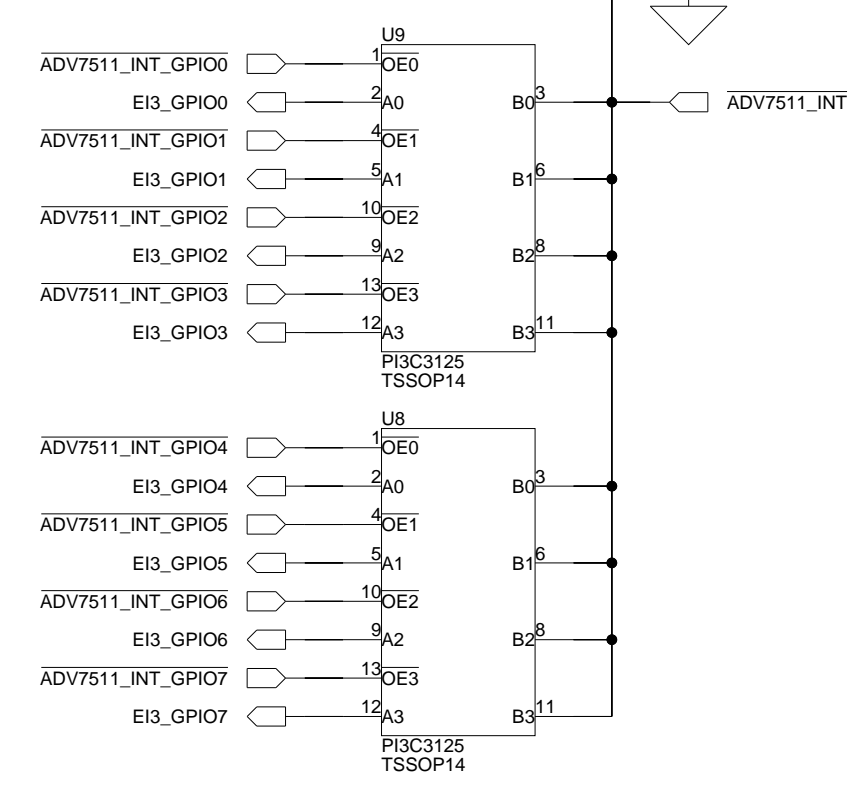
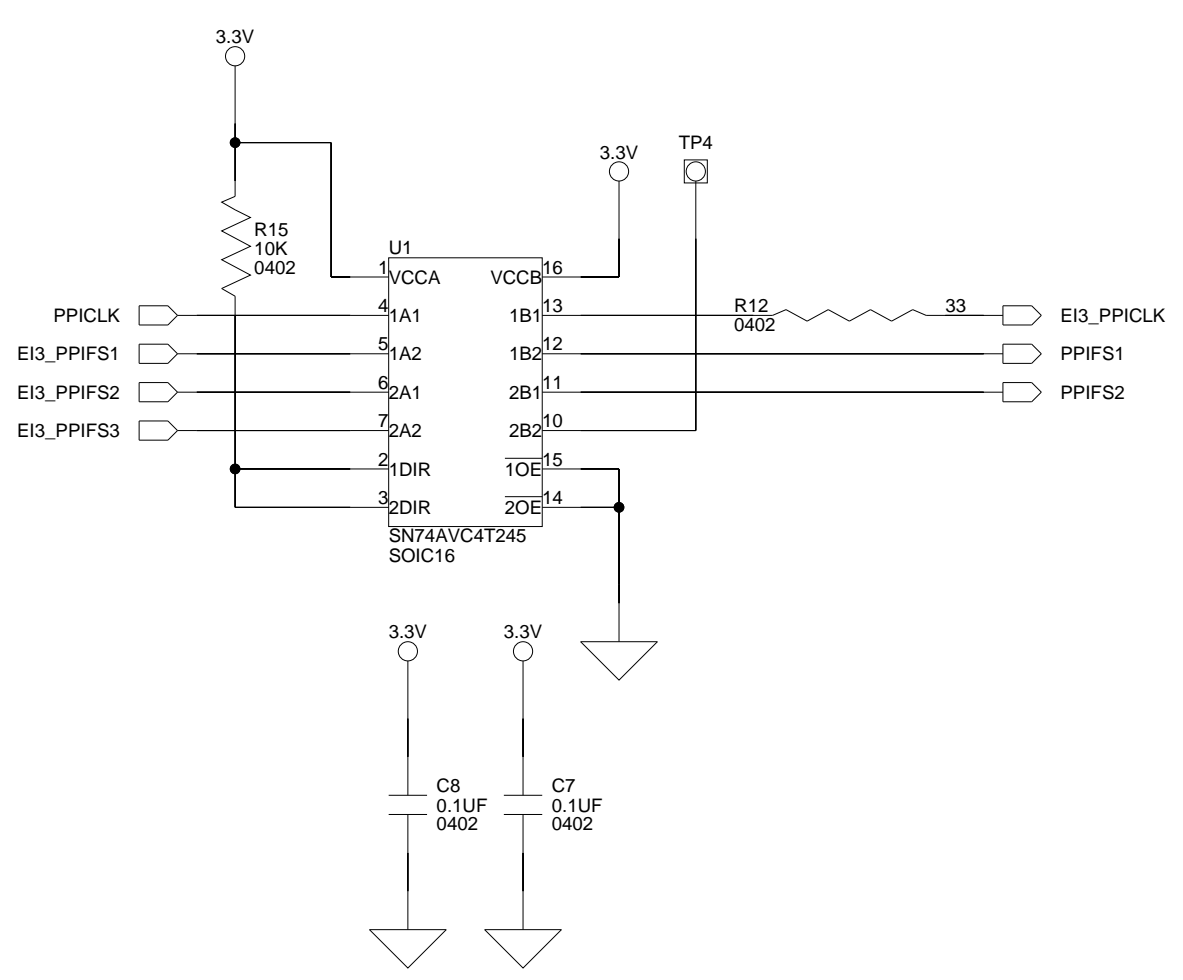
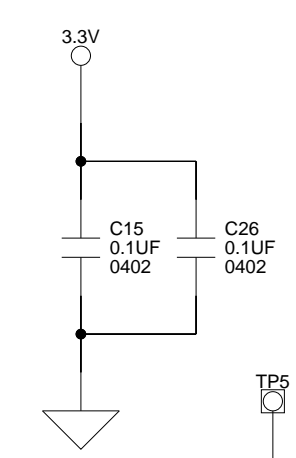
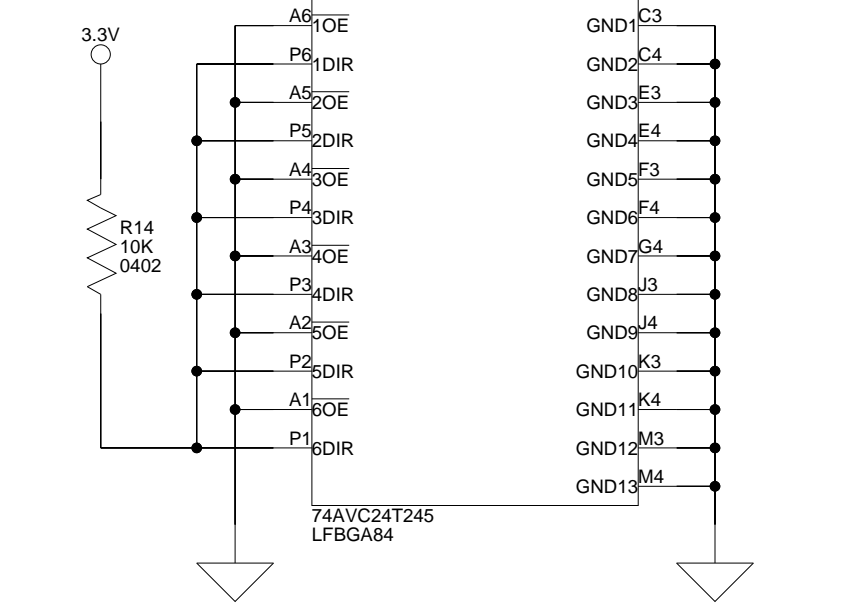
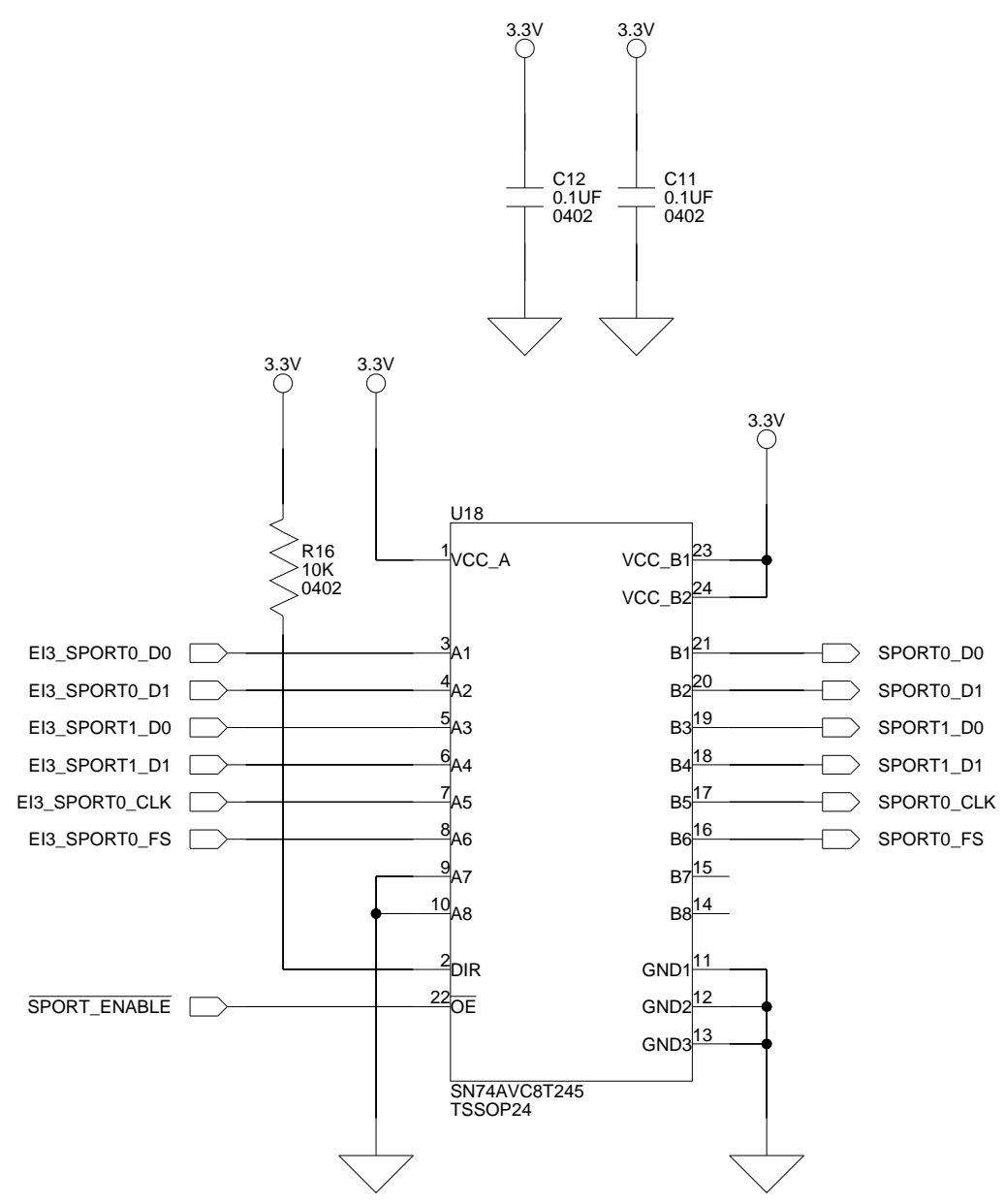
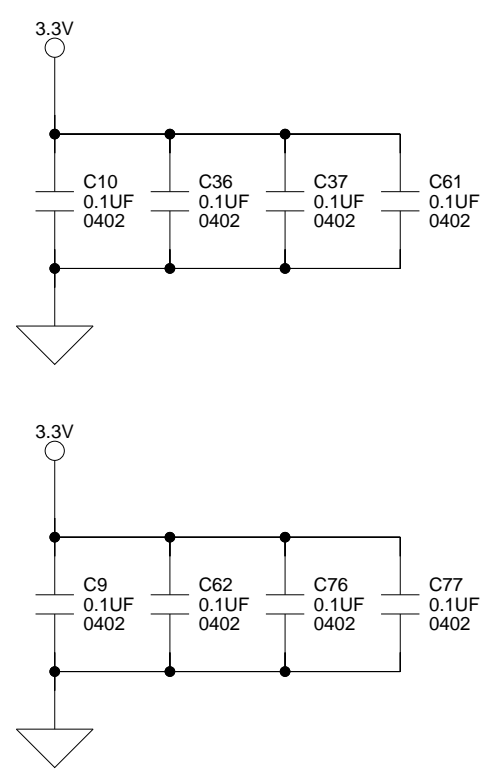
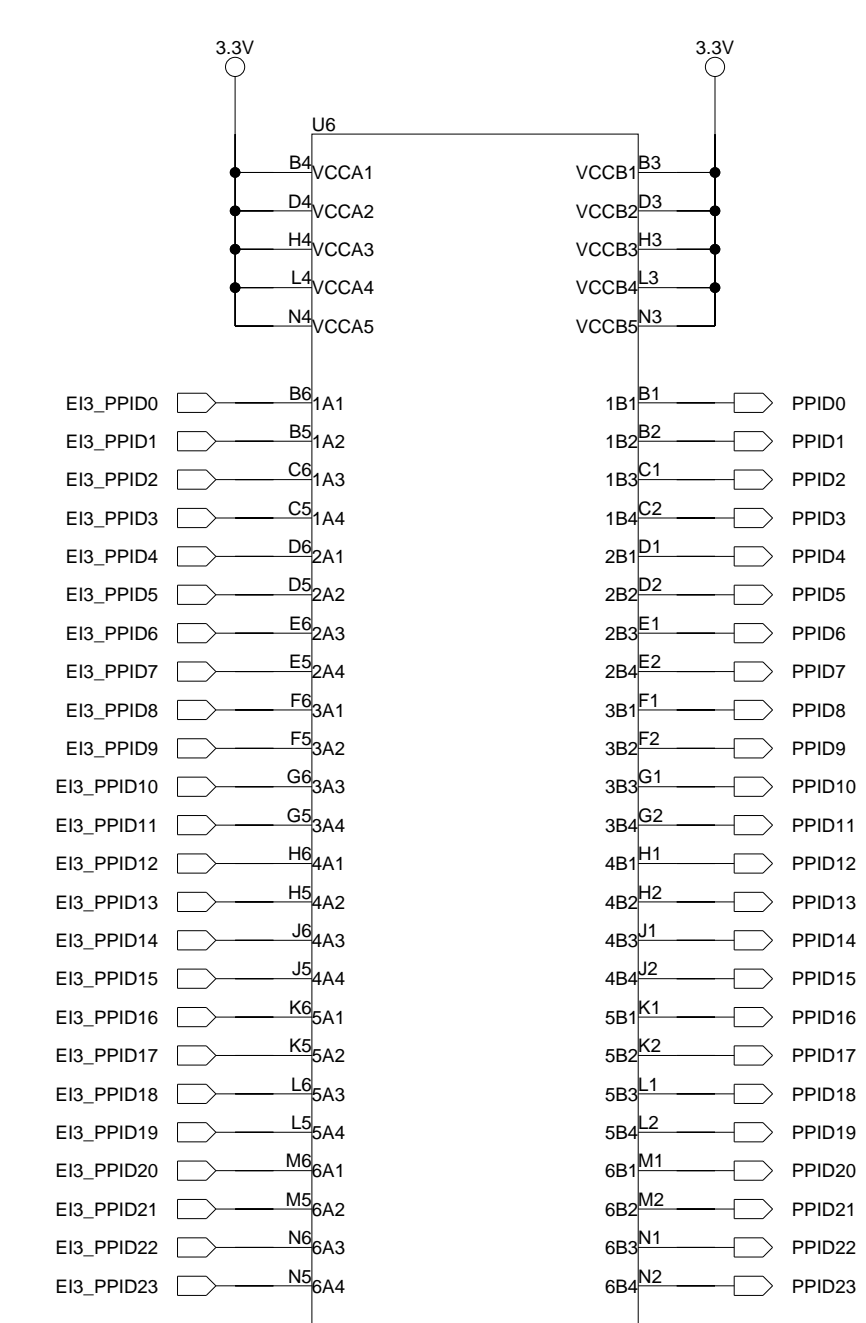

ANALOG DEVICES

20 Cotton Road
Nashua, NH 03063
PH: 1-800-ANALOGD

Title Video Encoder EI3 Extender Board Voltage Translators		
Size C	Board No. A0252-2010	Rev 1.0
Date	3/6/12	Sheet 3 of 8

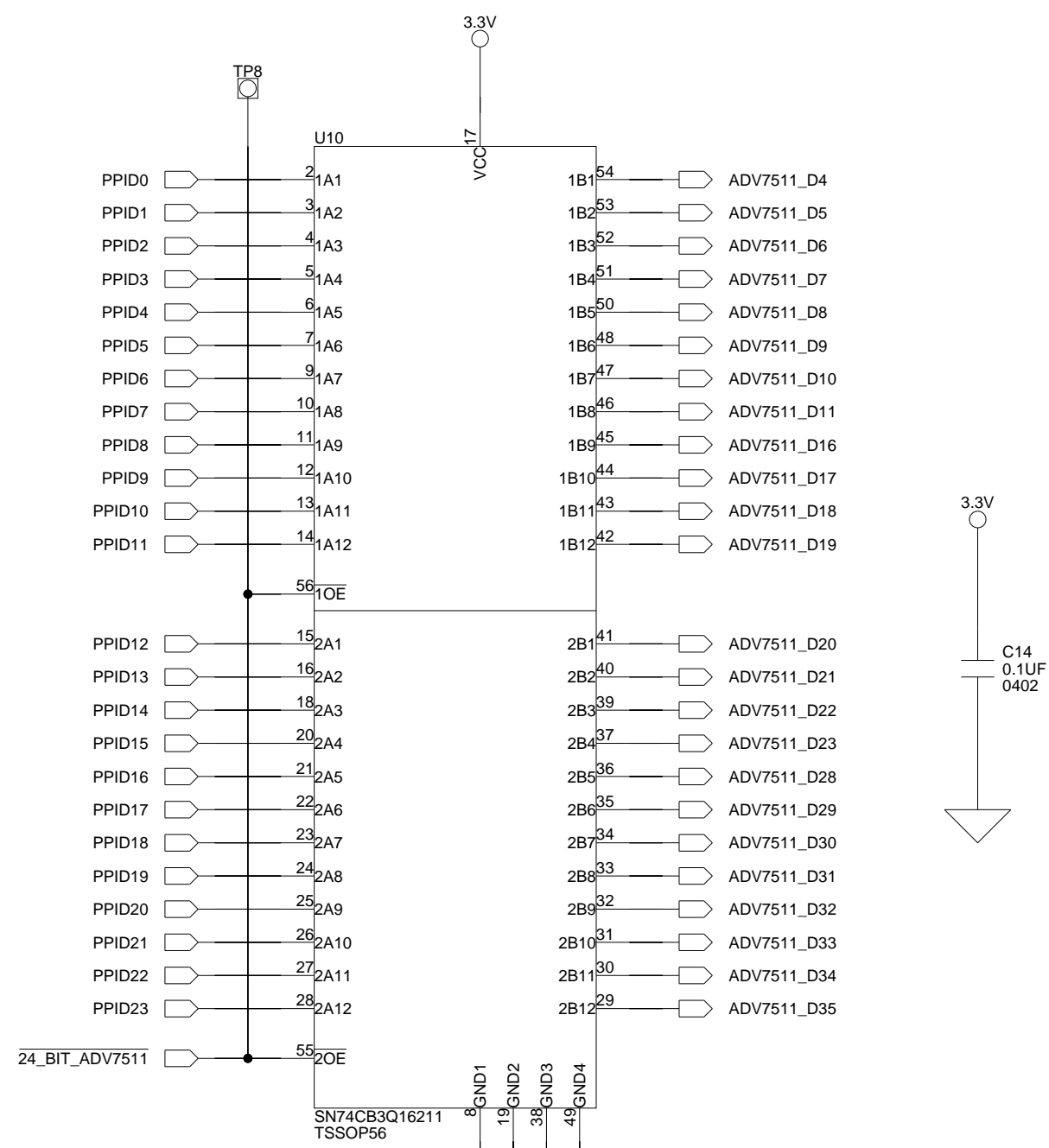

24-Bit Mode
RGB 4:4:4

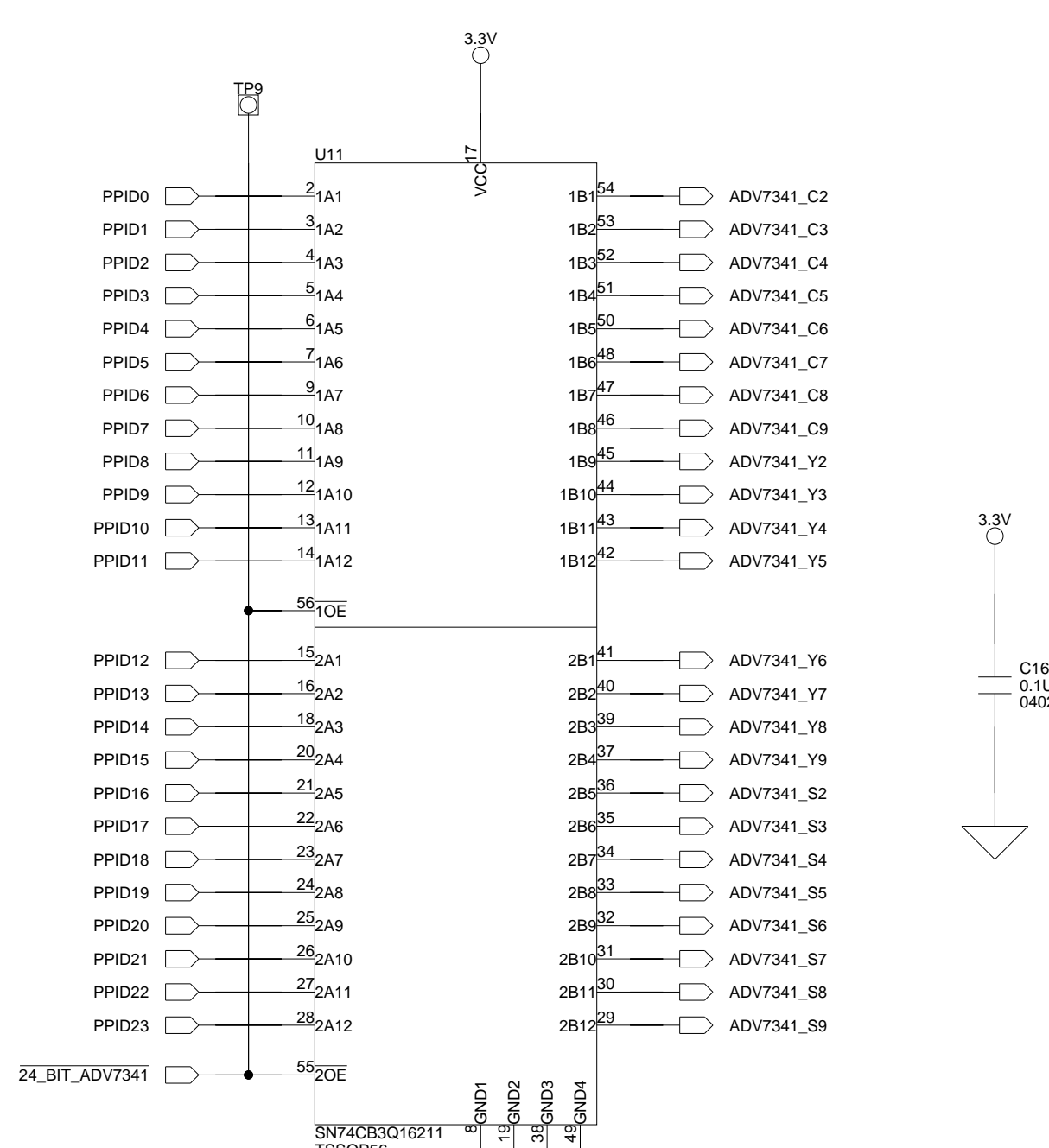

24-Bit Mode
RGB 4:4:4

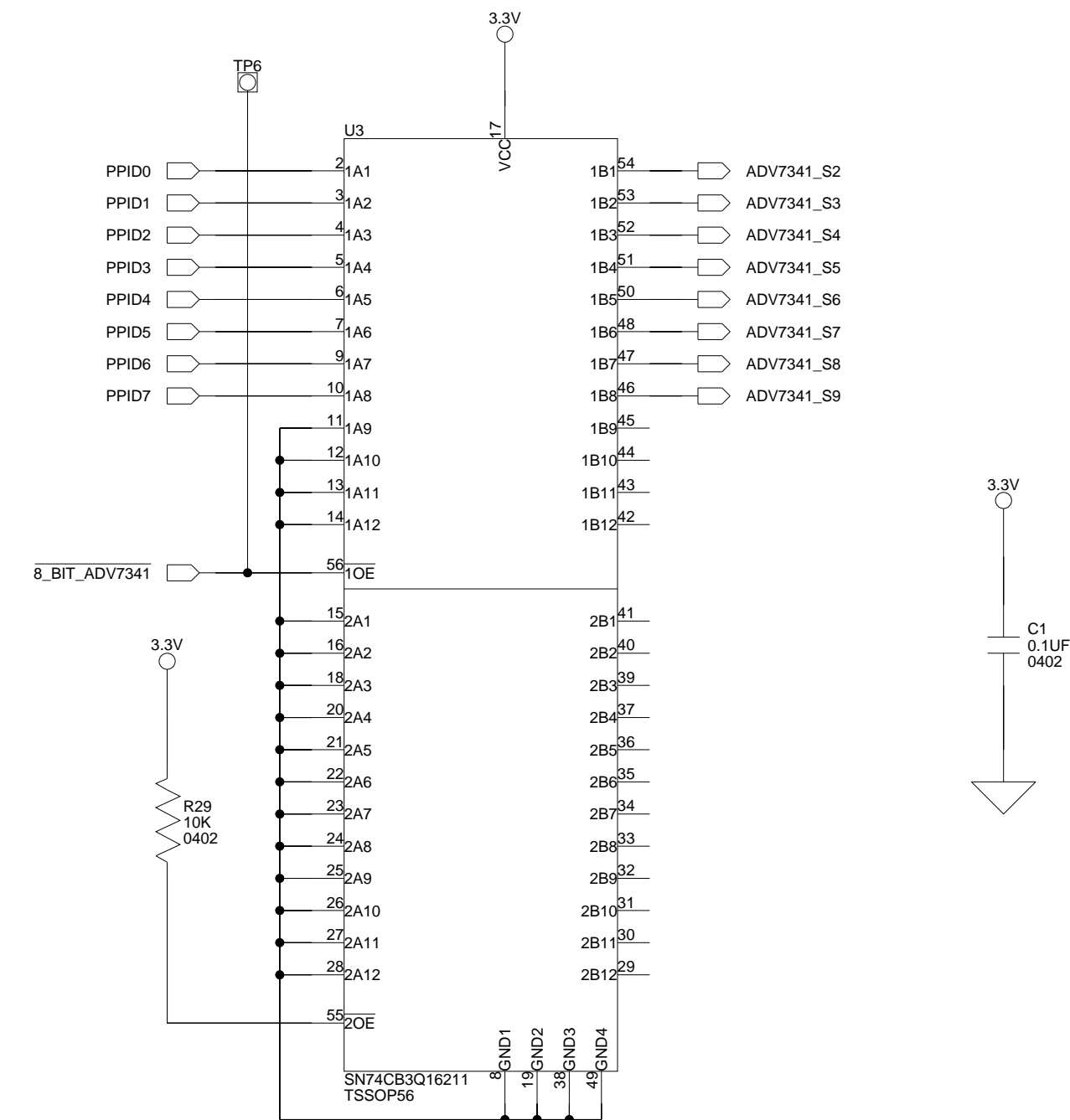

8-Bit Mode
YCbCr 4:2:2

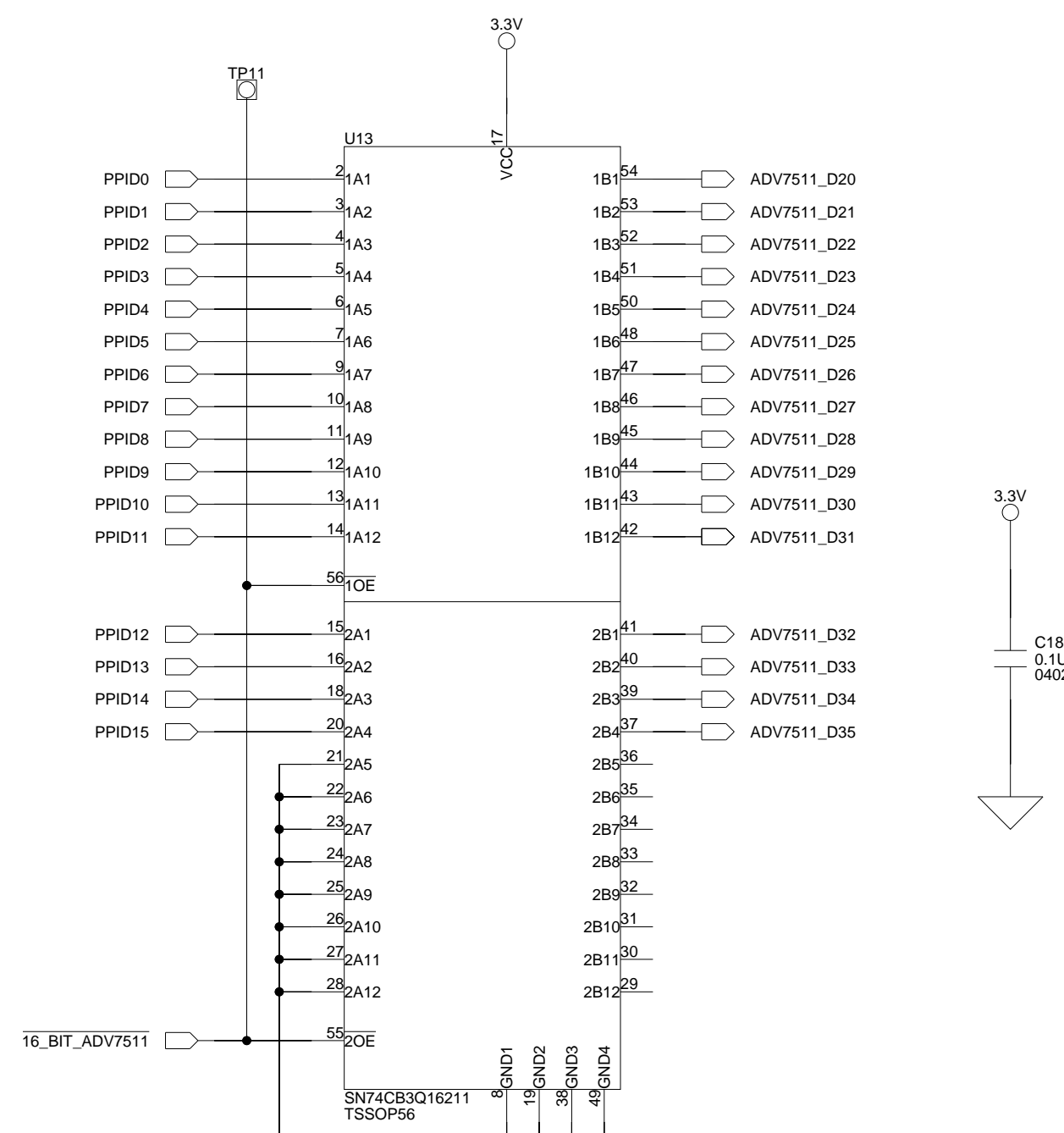

16-Bit Mode
YCbCr 4:2:2

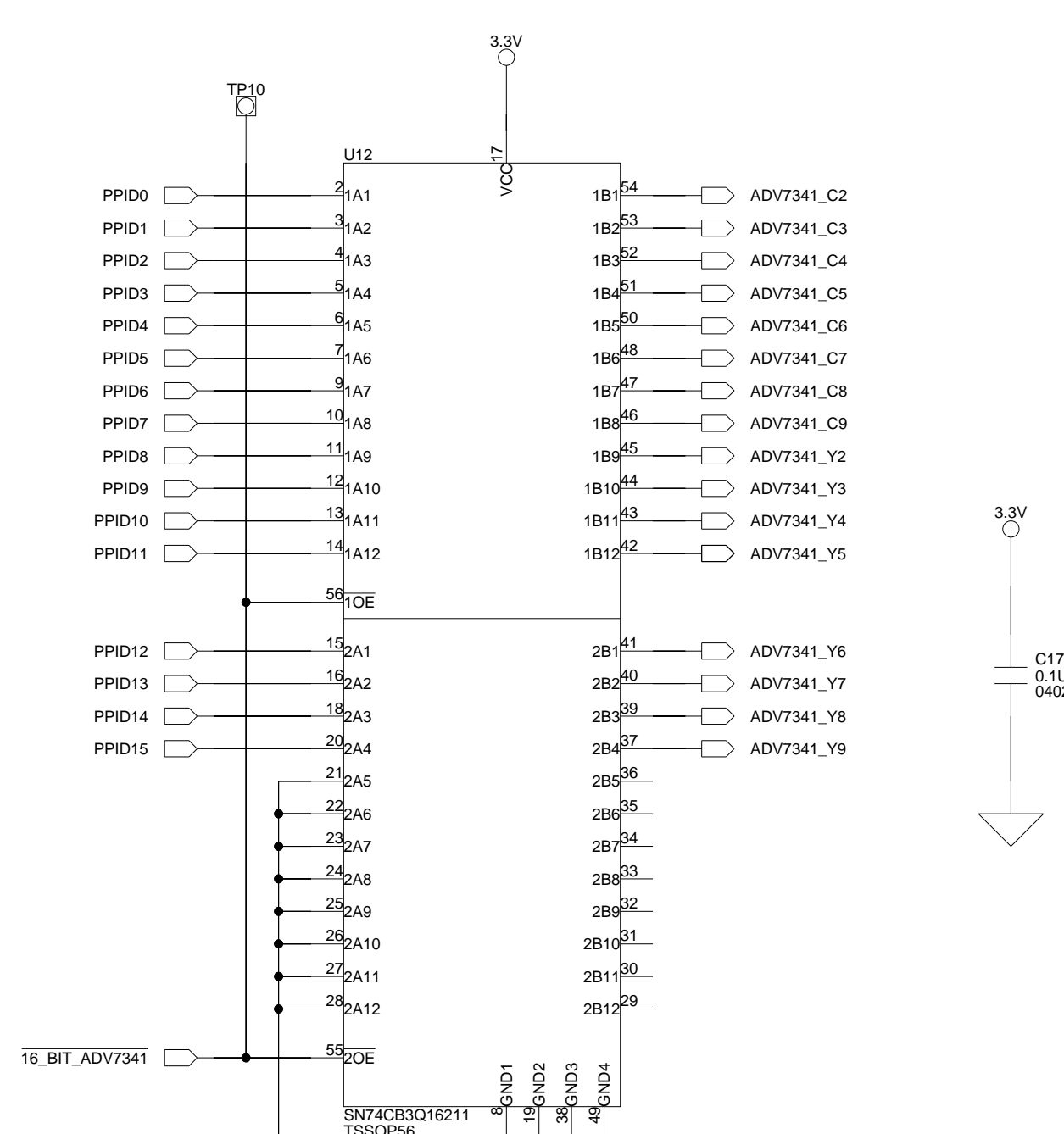

16-Bit Mode
YCbCr 4:2:2

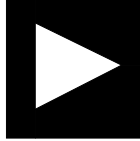
 ANALOG DEVICES		20 Cotton Road Nashua, NH 03063 PH: 1-800-ANALOGD	
		Title Video Encoder EI3 Extender Board Video Modes	
Size C	Board No.	A0252-2010	
Date	3/6/12	Sheet	4 of 8
		Rev	1.0

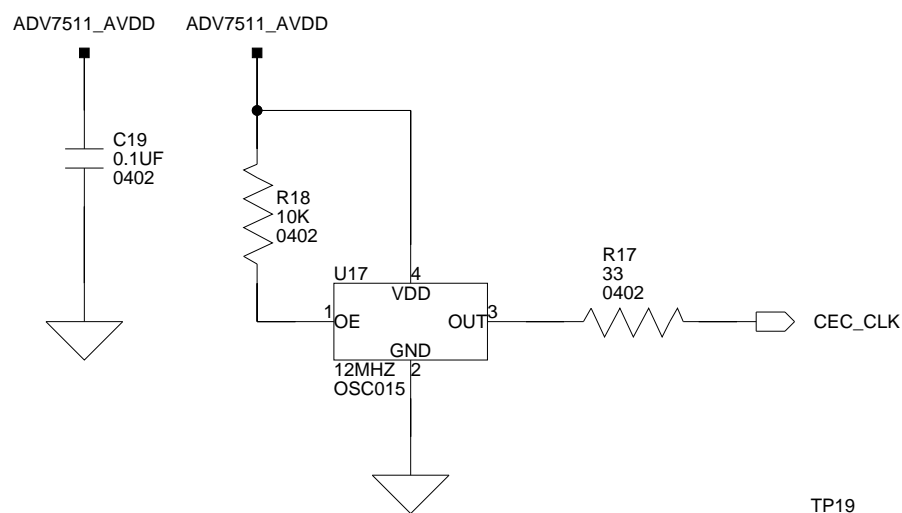

TWI Address 0111 001x
 x is the R/W bit. Read - 1, Write - 0

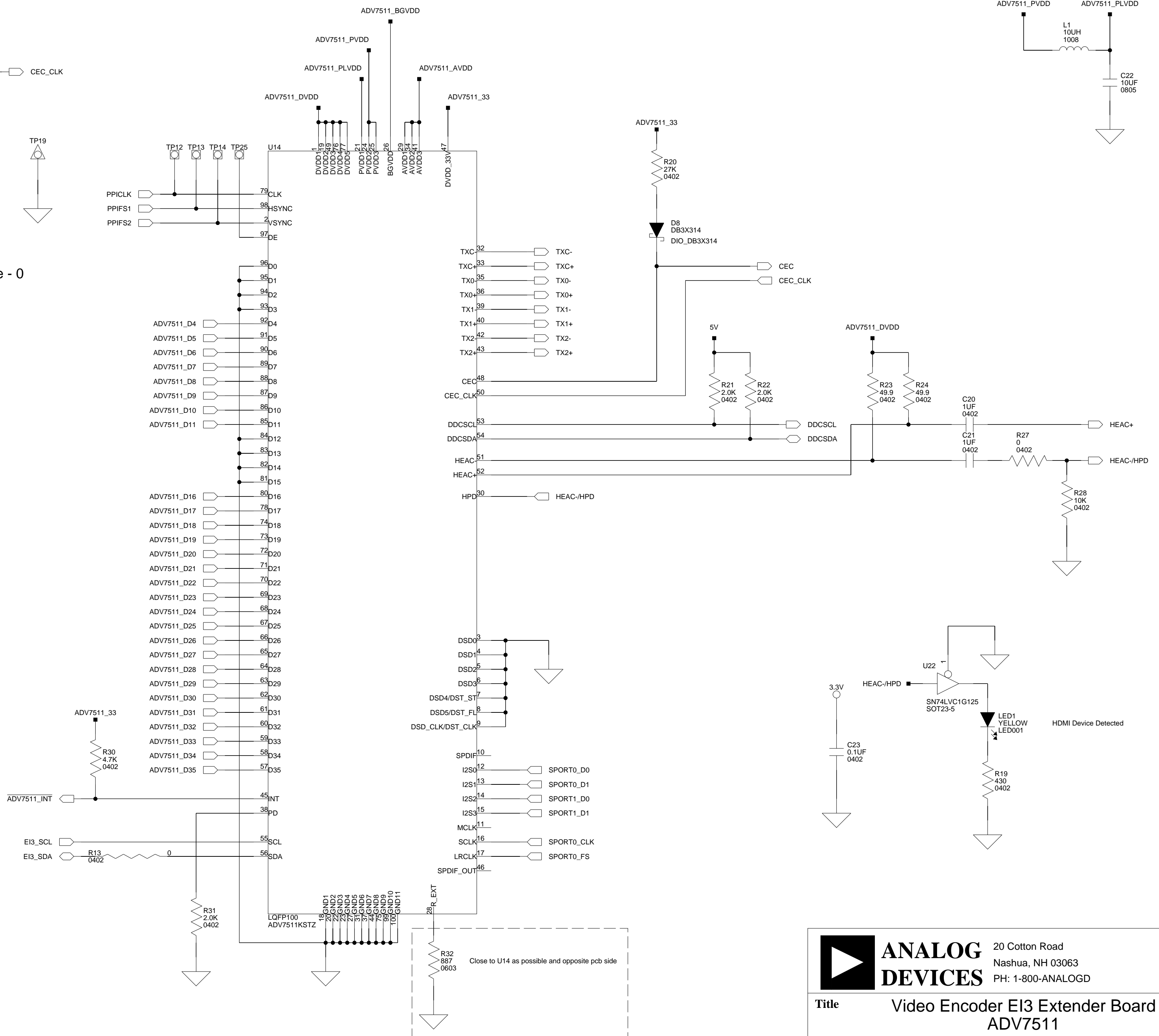

		20 Cotton Road Nashua, NH 03063 PH: 1-800-ANALOGD	
		Title Video Encoder EI3 Extender Board ADV7511	
Size C	Board No. A0252-2010	Rev 1.0	
Date 3/6/12	Sheet 5		of 8

TWI Address 0101 011x
 x is the R/W bit. Read - 1, Write - 0

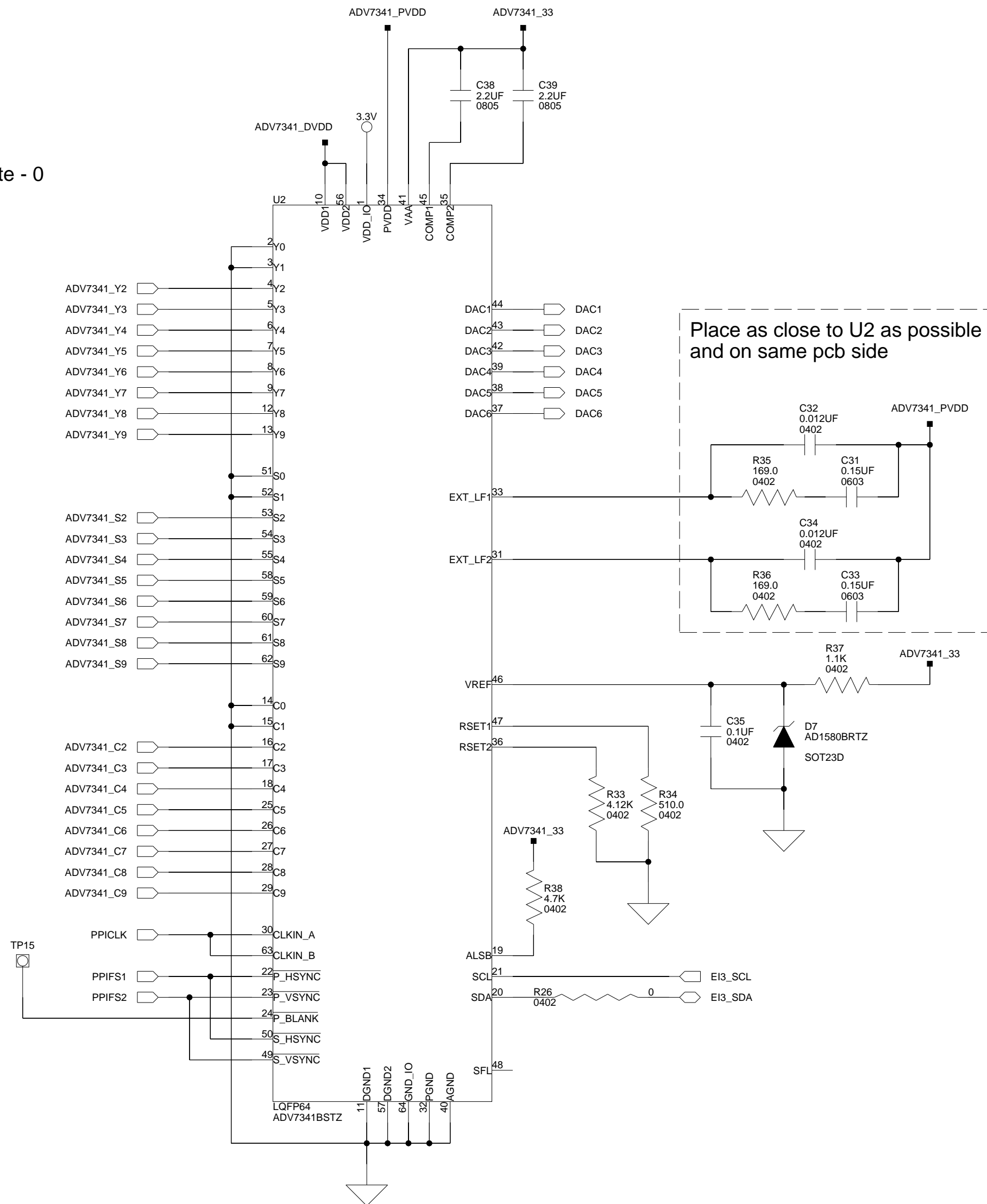

Place as close to U2 as possible
 and on same pcb side

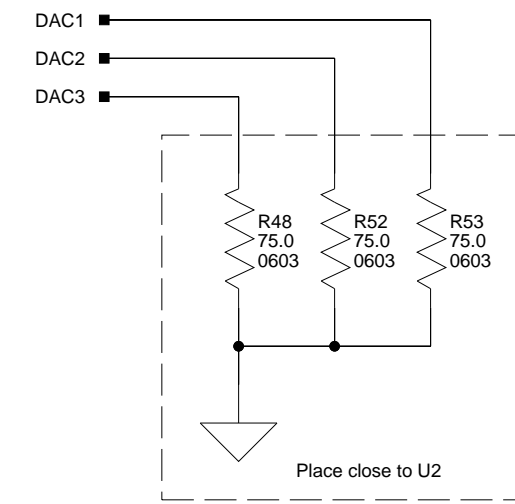

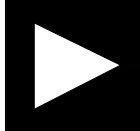
 ANALOG DEVICES		20 Cotton Road Nashua, NH 03063 PH: 1-800-ANALOGD	
		Title Video Encoder EI3 Extender Board ADV7341	
Size C	Board No. A0252-2010	Rev 1.0	
Date 3/6/12	Sheet 6		of 8

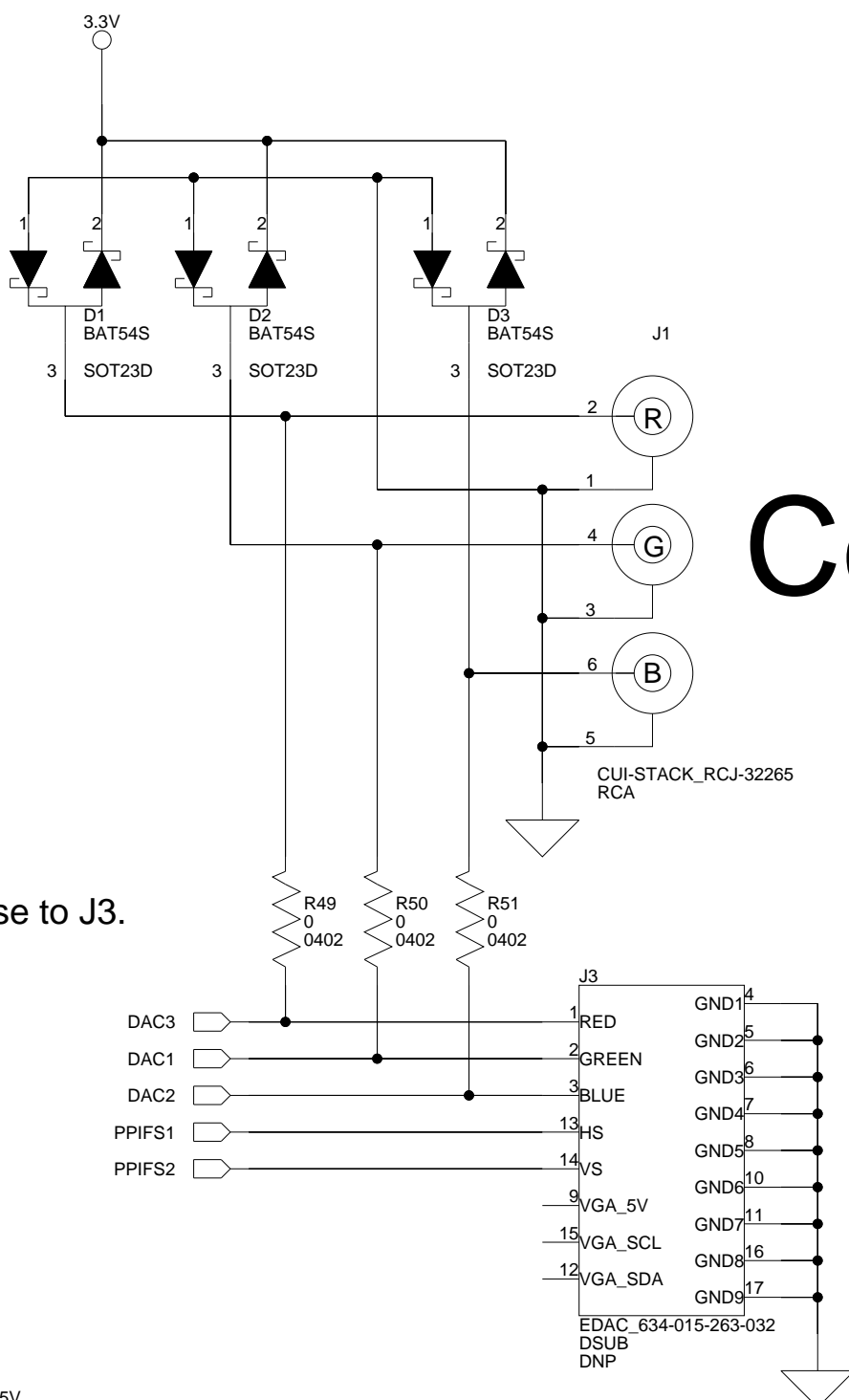

Component

VGA

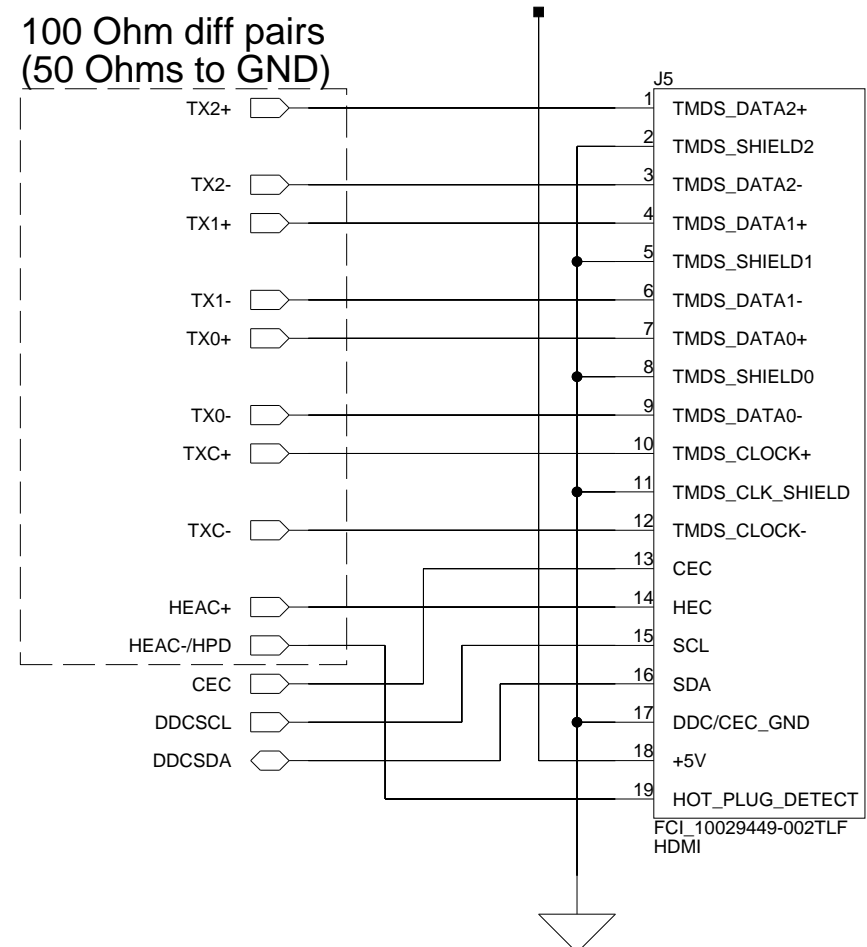

HDMI

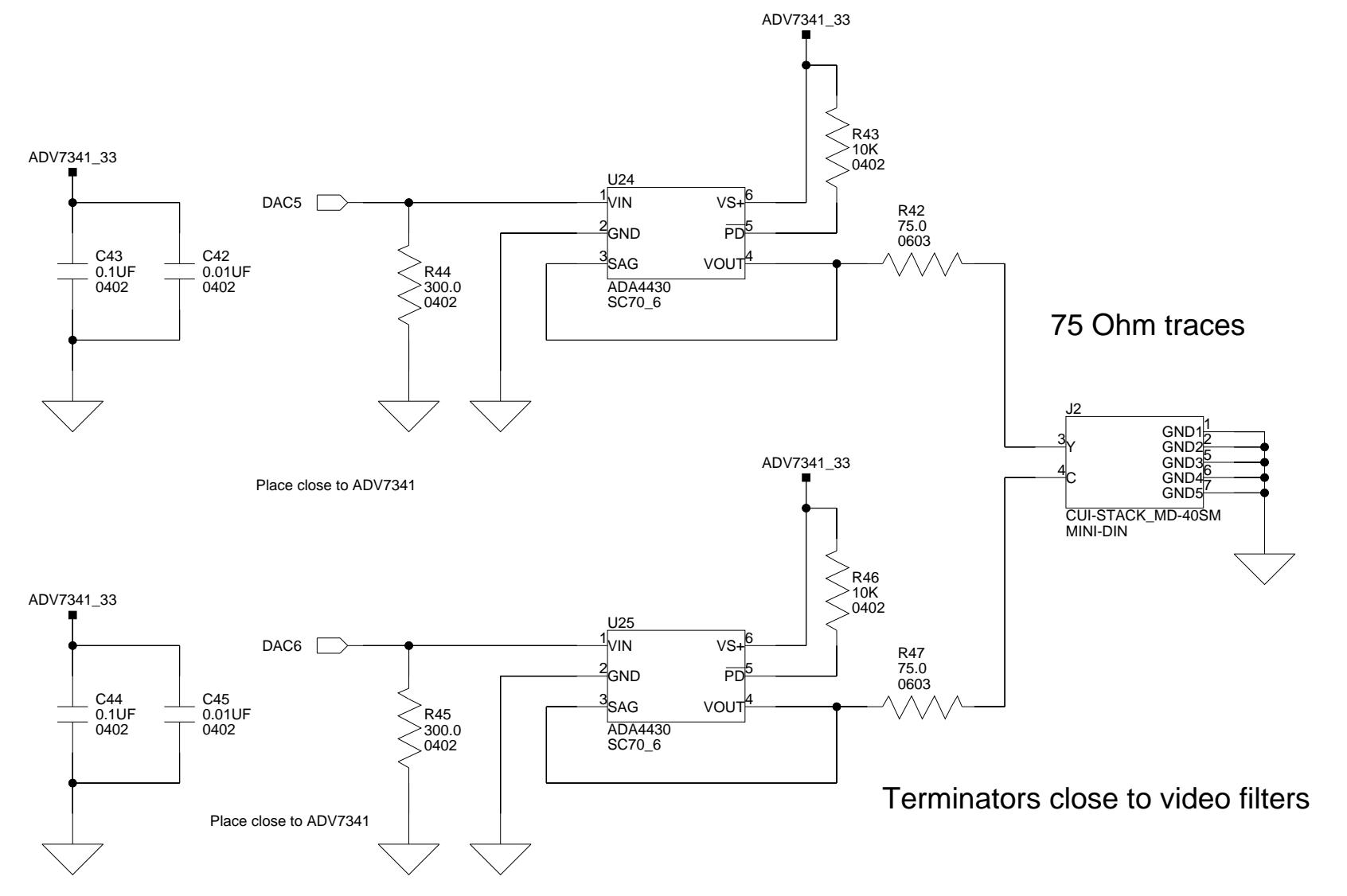
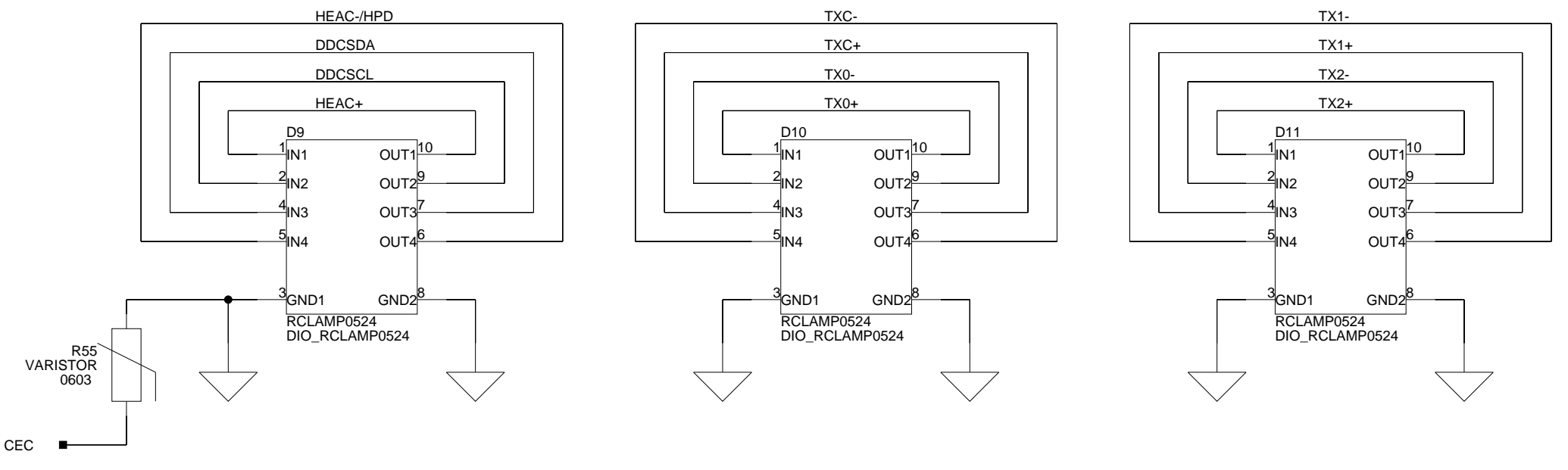

S-Video

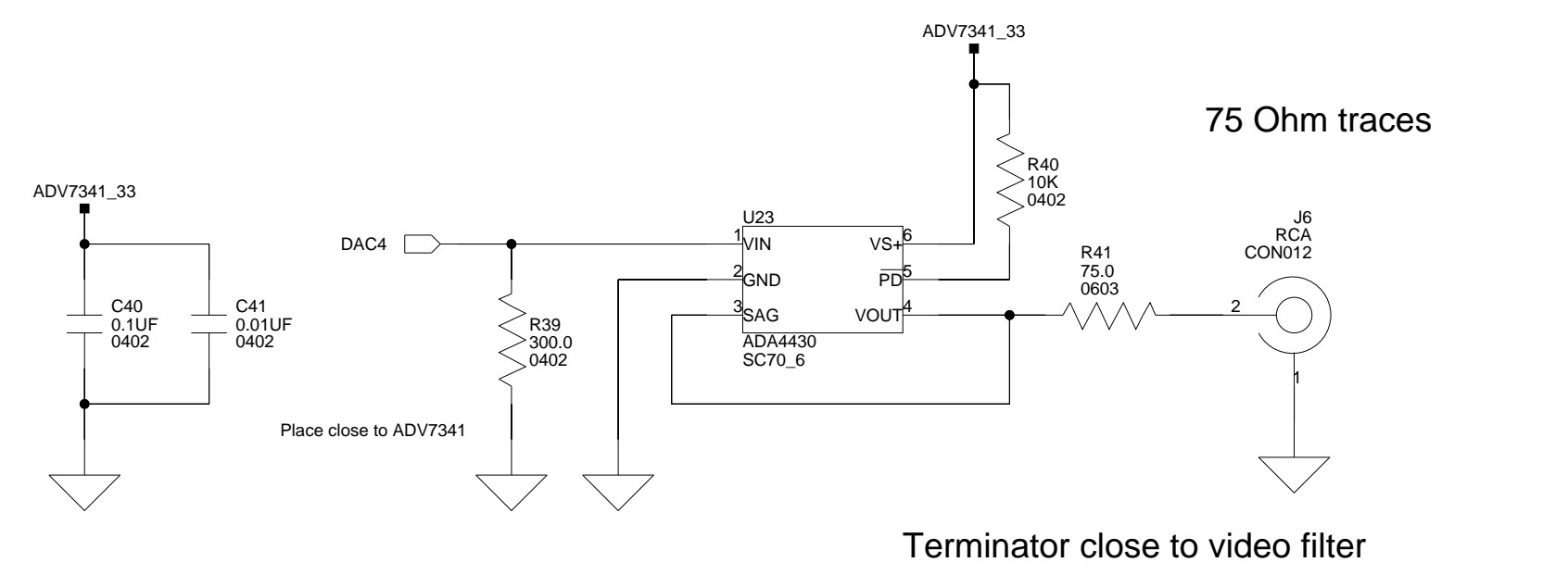

Composite

		20 Cotton Road Nashua, NH 03063 PH: 1-800-ANALOGD	
		Title Video Encoder E13 Extender Board Video Connectors	
Size C	Board No. A0252-2010	Rev 1.0	
Date 3/6/12	Sheet 7		of 8

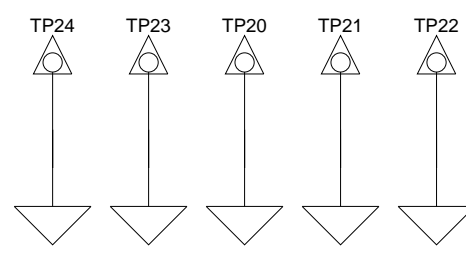
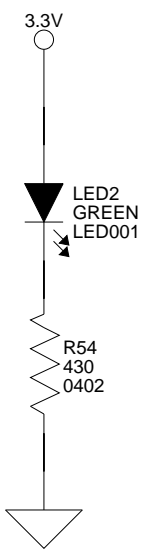

1.8V @ 1A

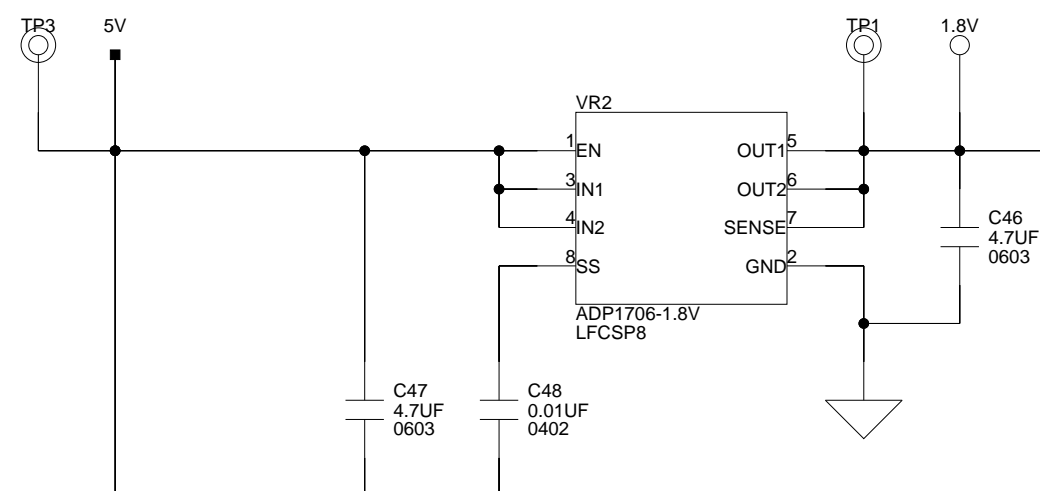

3.3V @ 1A

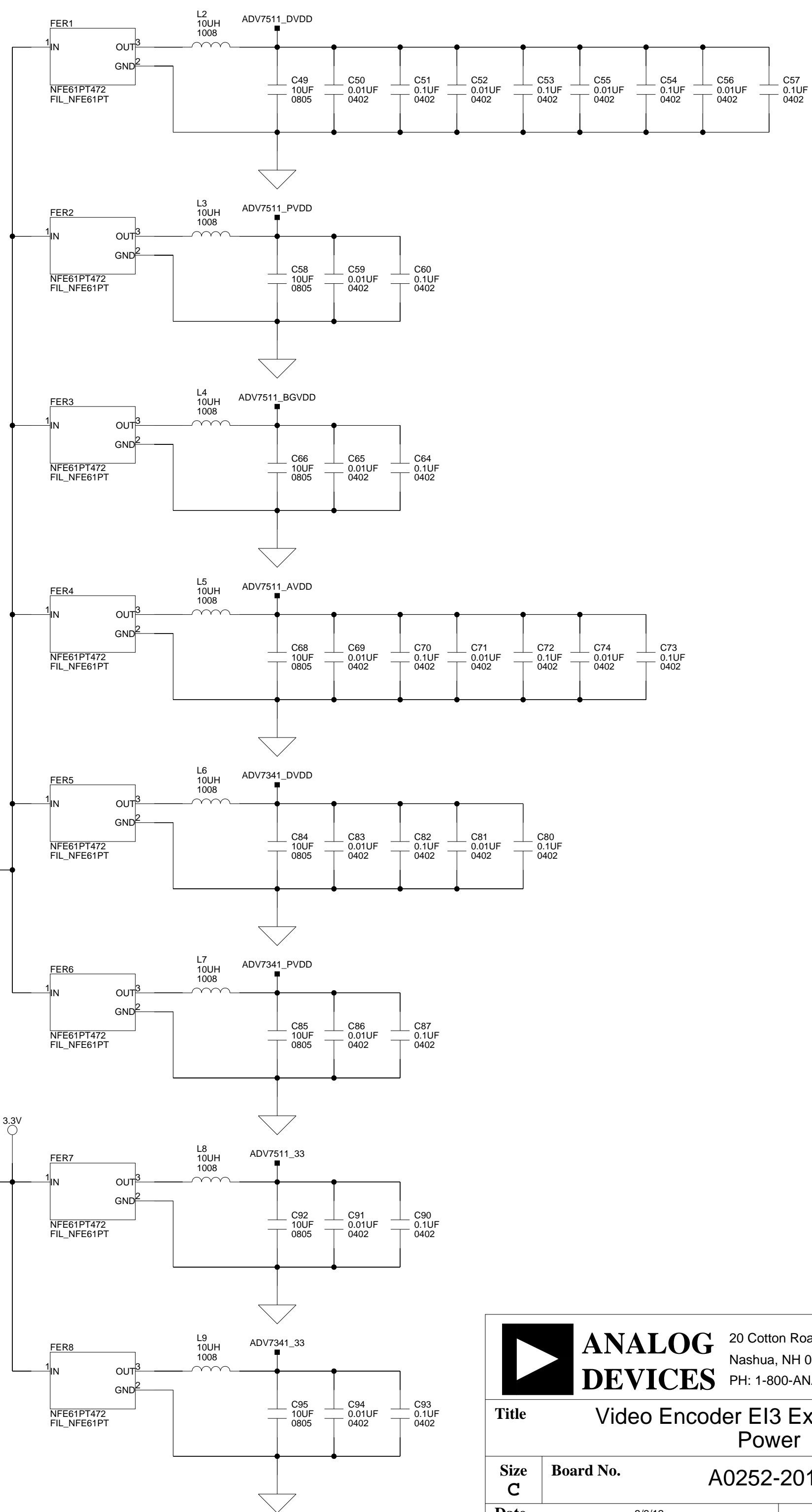
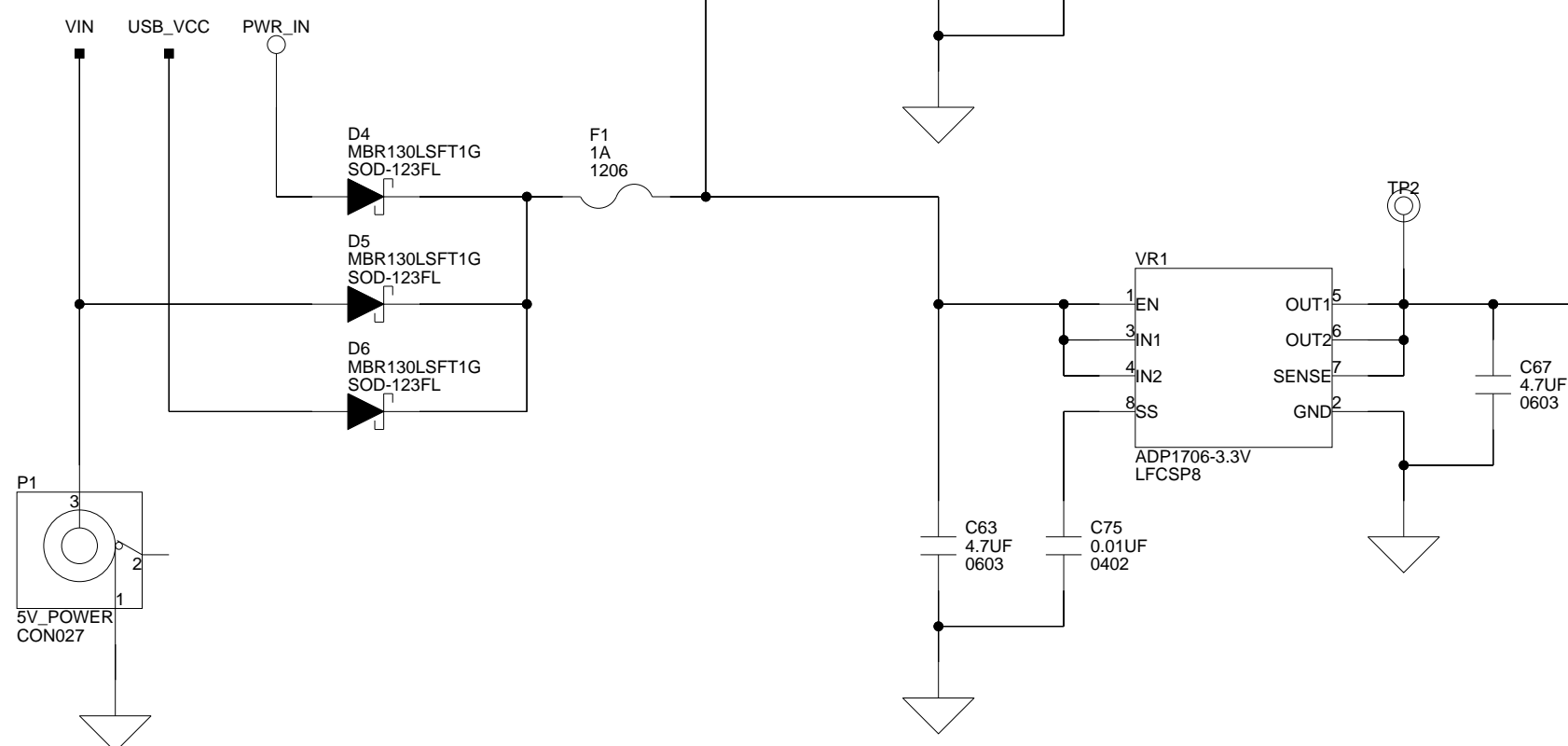

		20 Cotton Road Nashua, NH 03063 PH: 1-800-ANALOGD	
		Title Video Encoder EI3 Extender Board Power	
Size C	Board No. A0252-2010	Rev 1.0	
Date 3/6/12	Sheet 8		of 8

I INDEX

Numerics

27MHZ_CLK_EN signal, [2-10](#)

74MHZ_CLK_EN signal, [2-10](#)

A

ADV7341 video encoder, [ix](#)

ADV7511_INT_GPIOx signal, [2-10](#)

ADV7511 video encoder, [ix](#)

architecture, of Video Encoder EI3 Extender Board, [2-2](#)

B

bill of materials, [A-1](#)

block diagram of Video Encoder EI3 Extender Board, [2-2](#)

board design database, [1-8](#)

board schematic (Video Encoder EI3 Extender Board), [B-1](#)

bus switch, [2-5](#)

example, [2-5](#)

C

component connector (J14), [2-13](#)

composite connector (J6), [2-14](#)

configuration, of Video Encoder EI3 Extender Board, [1-3](#)

connector locations, [2-11](#)

connectors

120-pin 0.6 mm pitch, [2-12](#)

component (J14), [2-13](#)

composite (J6), [2-14](#)

expansion III (EI3) (J4), [2-12](#)

HDMI (J5), [2-13](#)

power (P1), [2-14](#)

single RCA jack, [2-14](#)

S-video DIN (J2), [2-12](#)

triple RCA jack (J4), [2-13](#)

contents, of this extender board package, [1-2](#)

D

design reference info, [1-8](#)

E

EngineerZone, [xiv](#)

expansion III (EI3) connectors (J4), [2-12](#)

extender board block diagram, [2-2](#)

F

FET switches, [2-3](#)

example, [2-4](#)

H

HDMI connector (J5), [2-13](#)

HDMI Detect LED (LED1), [2-15](#)

Index

I

installation, of Video Encoder EI3
Extender Board, [1-3](#)
interfaces, [x](#)

L

LEDs, [2-15](#)
HDMI Detect (LED1), [2-15](#)
power (LED2), [2-15](#)

M

mechanical switch, [2-4](#), [2-6](#)

N

notation conventions, [xv](#)

O

operating systems, supported, [1-2](#)

P

package contents, [1-2](#)
power connector (P1), [2-14](#)
power LED (LED2), [2-15](#)
product information, [xiii](#)
product overview, [ix](#)

R

related documents, [xv](#)
related processor publications, [xv](#)

S

schematic, of Video Encoder EI3 Extender
Board, [B-1](#)
signals
 $\overline{27\text{MHZ_CLK_EN}}$, [2-10](#)
 $\overline{74\text{MHZ_CLK_EN}}$, [2-10](#)
 $\overline{\text{ADV7511_INT_GPIOx}}$, [2-10](#)
 $\overline{\text{SPORT_ENABLE}}$, [2-10](#)
video encoder mode select, [2-10](#)
SoftConfig, [2-3](#)
overview, [2-3](#)
programming switches, [2-7](#)
software-controlled switches (SoftConfig),
[2-3](#)
 $\overline{\text{SPORT_ENABLE}}$ signal, [2-10](#)
supported operating systems, [1-2](#)
supported products, [xiii](#)
S-video connector (J2), [2-12](#)
switches
programming SoftConfig, [2-7](#)
system architecture, [2-2](#)
system requirements, [1-3](#)

T

technical support, [xii](#)

V

video connectors, [x](#)
Video Encoder EI3 Extender Board
interfaces, [x](#)
video encoder mode select, [2-10](#)
video interface, [x](#)
ADV7341, [x](#)
ADV7511, [x](#)