



Q406-A000 (1 input; 1 output)  
Q406-A001 (1 input; 1 output with Excitation Source)  
Q406-A002 (signal splitter: 1 input; 2 output)  
Q406-A003 (1 input; 2 output with Excitation Source)  
Q406-A004 (2 input; 2 output)

# ACTIONI/Q® Q406

## AC Powered DC Input Multi-Channel Isolator

Provides 1 or 2 Fully Isolated DC Output Signals  
in Proportion to 1 or 2 DC Inputs



- Field Configurable Input Ranges
- Field Configurable Output Ranges
- 1800VAC Isolation
- TouchCAL™ Technology
- High Density DIN Rail Mounting
- Universal AC Power 85 to 265 VAC
- SnapLoc™ Plug-in Terminals

### Description

The model Q406 is an AC powered, DIN rail mount, DC input signal conditioner, with 1800V isolation between input, output and power. The field configurable input and output feature offers flexible, wide ranging capability for DC current and voltage signals.

The Q406 is available as a single channel signal conditioner (1 input/1 output) or as a multi-channel signal conditioner (1 input/2 outputs, or 2 inputs/2 outputs). All models maintain the high 1800V isolation level from channel to channel, as well as input to output to power.

### TouchCAL Technology

Action has simplified setpoint calibration. Using a pushbutton instead of potentiometers, improvements in calibration resolution and reliability are realized due to the elimination of the potentiometers' mechanical variability. The thermal drift and mechanical variability of the potentiometers has been removed and replaced with a digitally stable circuit. Additionally, the inherent zero and span interactivity of analog amplifier circuitry is removed, providing 100% non-interactive adjustment.

The Q406 can be field configured for virtually any DC input to DC output within the limits specified. Calibration utilizes "TouchCAL" technology where the user simply configures the input for the current or voltage range via switches, then follows the Calibration Flow Chart. The output is set by adjusting the input until the desired output is present and then pressing the CAL button to store the output level.

Optionally available is a 24VDC excitation source (20mA max.) common to the input and isolated from AC power, which can be used to power a two- or three-wire transducer.

### Diagnostic LEDs

The Q406 has three diagnostic LEDs. The green (RUN) LED is used for diagnostics to indicate that power is on. It will flash quickly if the input signal is above the calibrated range or slowly if the input signal is below range. It is on continuously when the unit is functioning within the calibrated range.

The yellow (IN) LED is on while calibrating the input and the red (OUT) LED is on while calibrating the output.

### Configuration

The Q406 can be configured for input ranges from 10mV to 100V or 1mA to 100mA, with >90% input offset or will adjust down to <10% of full scale input span (except on 20mV/2mA range where maximum offset or gain adjustment is 50%). Unless a specific custom calibration is specified, the factory presets the Model Q406 as follows:

Input Range: 20mA (Current on)  
Input Configuration: Unipolar  
Calibrated Input: 4-20mA  
Operation: Direct (Reverse off)  
Calibrated Output: 4-20mA

For other I/O ranges, refer to the tables below.

**WARNING:** Do not change switch settings with power applied. Severe damage will result!

1. With power off, snap off the faceplate by lifting the right edge away from the heatsink. Slide the heatsink forward and off the module.
2. The single channel module has two eight position switch blocks, one for input and one for output. The dual output modules have a second board behind the heatsink. Gently lift this board away from the main board, rocking it back while lifting. The one input, two output module has one ten position switch block for input and channel 1 output, along with a two position switch for the second output. The two input, two output module has two ten position switch blocks, one for each channel.
3. For single channel modules, choose the desired input, function and output range from Table 1, 2, and 3. For multi-channel modules, use Table 4. Set the dip switches for the desired I/O.

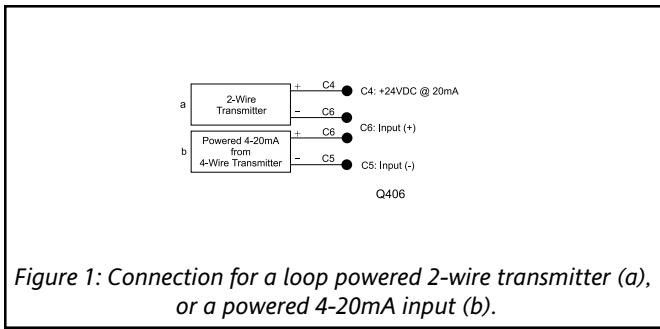

Figure 1: Connection for a loop powered 2-wire transmitter (a), or a powered 4-20mA input (b).

### Calibration

Note: For best results, calibration should be performed with the intended output load, in the operating environment, mounted on a DIN rail, allowing at least one hour for thermal equilibrium of the system.

1. Install the module on to a piece of DIN rail and the I/Q Rail mounting combination. See the I/Q Rail Data sheet for details.

Note: An I/Q Rail is required to deliver power to the modules. See ordering information.

2. Connect the input to a calibrated DC source and the output to a voltage or current meter. Apply power and allow the system to reach thermal equilibrium (approx. 20 minutes).

3. Adjust the input signal to the desired maximum and observe that the green LED is on or flashing. Push the CAL button and hold it down for more than 5 seconds (until the yellow and Green LEDs are flashing).

Table 1: Input Range Settings for Single Channel Modules

| Ranges  |         | Selector SW1 |   |   |   |
|---------|---------|--------------|---|---|---|
| Voltage | Current | 1            | 2 | 3 | 4 |
| 20mV    | 2mA     |              |   | ■ | ■ |
| 50mV    | 5mA     |              | ■ |   |   |
| 100mV   | 10mA    |              | ■ |   | ■ |
| 200mV   | 20mA    |              | ■ | ■ |   |
| 500mV   | 50mA    |              | ■ | ■ | ■ |
| 1V      | 100mA   | ■            |   |   |   |
| 2V      |         | ■            |   |   | ■ |
| 5V      |         | ■            |   | ■ | ■ |
| 10V     |         | ■            | ■ |   |   |
| 25V     |         | ■            | ■ | ■ | ■ |
| 50V     |         | ■            | ■ | ■ | ■ |
| 100V    |         | ■            | ■ | ■ | ■ |

Key: ■ = 1 = ON or Closed

Table 2: Input Function Settings for Single Channel Modules

| Type     | Selector SW1 |   |   |   |
|----------|--------------|---|---|---|
|          | 5            | 6 | 7 | 8 |
| Unipolar | ■            | - | - | - |
| Bipolar  | -            | - | - | - |
| Reverse  | -            | ■ | - | - |
| Direct   | -            | - | - | - |
| Current  | -            | - | - | ■ |
| Voltage  | -            | - | - | ■ |

Key: ■ = 1 = ON or Closed; - = n/a

4. When the yellow and green LEDs stop flashing, the yellow and red LEDs will be on. Push the CAL button momentarily (the yellow and green LEDs will be on).

Note: To quit the calibration mode and reset the unit, push the CAL button and hold for more than 5 seconds. Or, wait for more than two minutes and the unit will timeout and reset itself to the previously stored calibration.

5. Apply the maximum input signal level desired, and push the CAL button to store (the yellow LED will be on).

6. Apply the minimum input signal level desired, and push the CAL button to store (the green and red LED will be on).

7. Adjust the input signal while monitoring the output signal until the output is at the desired maximum level (e.g. 20.00mA), then push the CAL button to store (the red LED will be on).

8. Adjust the input signal while monitoring the output signal until the output is at the desired minimum level (e.g. 4.00mA), then push the CAL button to store (the yellow, green and red LEDs will be on).

9. Push the CAL button one final time to store the calibration data. The green LED will be on if the input is within the calibrated range.

Table 3: Output Range Settings for Single Channel Modules

| Ranges    | Selector SW2 |   |   |   |   |   |   |   |
|-----------|--------------|---|---|---|---|---|---|---|
|           | 1            | 2 | 3 | 4 | 5 | 6 | 7 | 8 |
| 0 to 5V   | ■            | ■ | ■ | ■ |   |   |   |   |
| 0 to 10V  | ■            | ■ | ■ | ■ |   |   |   |   |
| 0 to 1mA  |              |   | ■ | ■ |   |   |   |   |
| 4 to 20mA |              |   |   |   |   | ■ | ■ | ■ |
| 0 to 20mA | ■            | ■ |   |   |   | ■ | ■ | ■ |

Key: ■ = 1 = ON or Closed

Table 4: I/O Range & Function Settings for Dual Channel Modules

| Ranges    |         | Selector SW1 or SW2* |   |   |   |   |   |   |   |   |    | SW2** |   |
|-----------|---------|----------------------|---|---|---|---|---|---|---|---|----|-------|---|
| Voltage   | Current | 1                    | 2 | 3 | 4 | 5 | 6 | 7 | 8 | 9 | 10 | 1     | 2 |
| 20mV      | 2mA     |                      |   | ■ | ■ |   |   |   |   |   |    |       |   |
| 50mV      | 5mA     |                      | ■ |   |   |   |   |   |   |   |    |       |   |
| 100mV     | 10mA    |                      | ■ | ■ |   |   |   |   |   |   |    |       |   |
| 200mV     | 20mA    |                      | ■ | ■ |   |   |   |   |   |   |    |       |   |
| 500mV     | 50mA    |                      | ■ | ■ | ■ |   |   |   |   |   |    |       |   |
| 1V        | 100mA   | ■                    |   |   |   |   |   |   |   |   |    |       |   |
| 2V        |         | ■                    |   |   | ■ |   |   |   |   |   |    |       |   |
| 5V        |         | ■                    |   | ■ | ■ |   |   |   |   |   |    |       |   |
| 10V       |         | ■                    | ■ |   |   |   |   |   |   |   |    |       |   |
| 25V       |         | ■                    | ■ | ■ |   |   |   |   |   |   |    |       |   |
| 50V       |         | ■                    | ■ | ■ | ■ |   |   |   |   |   |    |       |   |
| 100V      |         | ■                    | ■ | ■ | ■ |   |   |   |   |   |    |       |   |
| Unipolar  |         |                      |   |   | ■ |   |   |   |   |   |    |       |   |
| Voltage   |         |                      |   |   |   |   | ■ |   |   |   |    |       |   |
| Current   |         |                      |   |   |   |   |   | ■ |   |   |    |       |   |
| Output    |         | 1                    | 2 | 3 | 4 | 5 | 6 | 7 | 8 | 9 | 10 | 1     | 2 |
| 0 to 5V   |         |                      |   |   |   |   |   |   |   | ■ | ■  | ■     | ■ |
| 0 to 10V  |         |                      |   |   |   |   |   |   |   | ■ | ■  |       |   |
| 0 to 1mA  |         |                      |   |   |   |   |   |   |   |   | ■  | ■     |   |
| 4 to 20mA |         |                      |   |   |   |   |   |   |   |   |    |       |   |

Key: ■ = 1 = ON or Closed  
 \*Applies to dual channel model  
 \*\*SW2, two position switch applies only to 1 input, 2 output module

Note that 0-20mA output is NOT available on multichannel units. Note also that Reverse Action is NOT available on multichannel units.

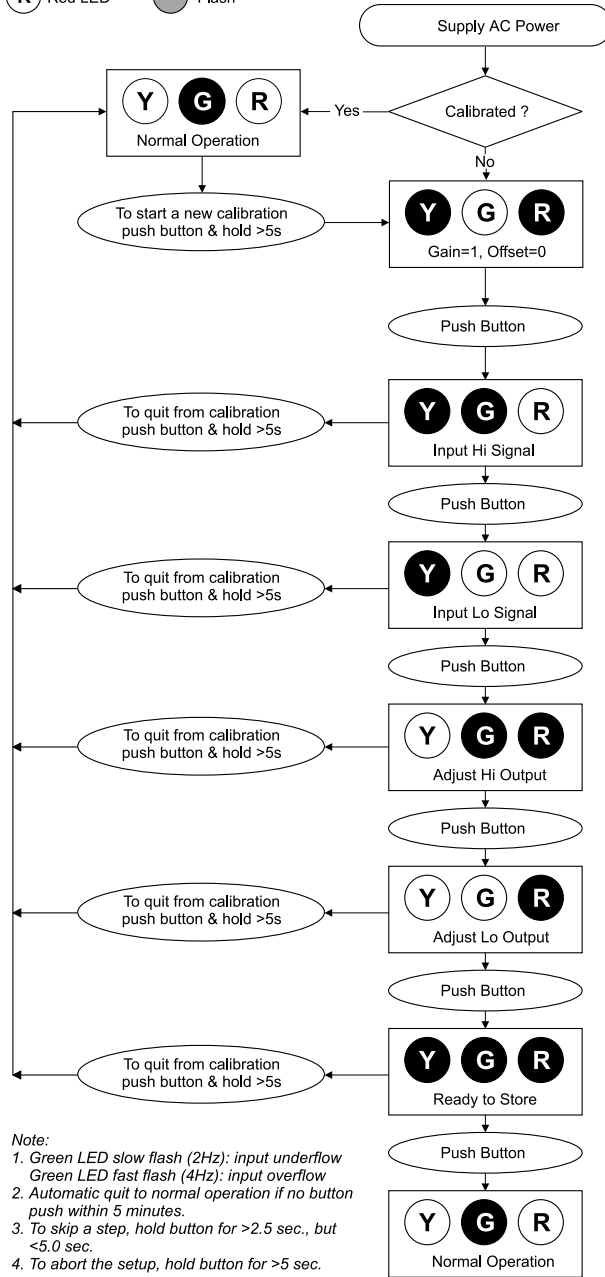
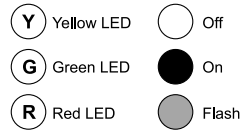

Figure 2: Q406 Calibration Flow Chart

## Specifications

### Inputs:

- Voltage:
  - Range Limits: 10mV to 100V (see Table 1)
  - Impedance:  $\geq 100k$  ohms
  - Overvoltage: 200V continuous
- Current Input:
  - Range Limits: 1mA to 100mA
  - Impedance: 20 ohms typical
  - Overcurrent: 170mA, protected by self resetting fuse
  - Overvoltage: 60V
- Pushbutton Adjustment (inputs > 10mV)
  - Effective zero offset:  $\geq 90\%$
  - Effective span turn down:  $\geq 90\%$  except 20mV/2mA range in which 50% is max. zero offset and span turndown

### Outputs:

- Voltage:
  - Output: 0-5V, 0-10V
  - Source Impedance: < 10 ohms
  - Drive: 10mA max.
- Current:
  - Output: 4-20mA, 0-1mA (0-20mA on single channel versions only)
  - Source Impedance: > 100k ohms
- Compliance:
  - 0-1mA: 7.5V max. (7.5k ohms)
  - 4-20mA: 12V max. (600 ohms)\*
  - 0-20mA: 12V max. (600 ohms)
  - \*10V max. (500 ohms) on dual out versions

### Output Ripple:

- < 50% offset or span adjust: < 0.1% off full scale span or 25mV RMS, whichever is greater
- > 50% offset or span adjust: < 0.2% of full scale span or 50mV RMS, whichever is greater.

## Ordering Information

### Models & Accessories

#### Specify:

1. Model:
  - Q406-A000**: one input, one output DC Isolator
  - Q406-A001**: one input, one output DC Isolator with 24VDC excitation source
  - Q406-A002**: one input, two output DC Isolator with 24VDC excitation source
  - Q406-A003**: one input, two output DC Isolator with 24VDC excitation source
  - Q406-A004**: two input, two output DC Isolator
2. Specify I/Q Rail type and quantity (required)
3. Custom Calibration: **C620** - calibrates units to a customer specified range.
4. Accessories: (see Accessories)

### Accessories

Action/I/Q modules mount on standard TS32 (model MD02) or TS35 (model MD03) DIN rail. In addition the following accessories are available:

- MD02** TS32 DIN rail
- MD03** TS35 x 7.5 DIN rail
- IQRL-2002** 2 Position I/Q Rail & DIN rail
- IQRL-2004** 4 Position I/Q Rail & DIN rail
- IQRL-2008** 8 Position I/Q Rail & DIN rail

## Output Accuracy:

- > 2mA / > 20mV input spans:
  - $\pm 0.1\%$  of full-scale input typical,  $\pm 0.2\%$  maximum
- < 2mA / < 20mV input spans:
  - $\pm 0.35\%$  of fullscale input typical,  $\pm 0.5\%$  maximum; including linearity, repeatability and hysteresis @ 23C.

## Response Time: 200mSec, typical

**Stability:**  $\pm 0.025\%$  of full scale /C, maximum for fullscale and zero

**Excitation Voltage (optional):** 24VDC, 20mA maximum

**Common Mode Rejection:** 120dB at DC, > 90dB at 60Hz

**Isolation:**  $\geq 1800$ VDC or peak AC between input, output, power and channel to channel

**ESD Susceptibility:** Capable of meeting IEC 801-2 level 3(8kV)

## Humidity (non-condensing):

- Operating: 15 to 95% RH @ 45°C
- Soak: 90% RH for 24 hours @ 60°C

## Temperature:

- Operating: 0 to 55°C (32 to 131°F)
- Storage: -25 to 70°C (-13 to 158°F)

**Power:** 2.5W max; 100 to 240VAC,  $\pm 10\%$ , 50 to 400Hz

**Wire Terminals:** Socketed screw terminals for 12-22 AWG

## Agency Approvals:

- UL recognized per standard UL508 (File No. E99775).
- CE compliance per EMC directive 89/336/EEC and low voltage 73/23/EEC.

| Terminal | Connection        | Terminal | Connection              |
|----------|-------------------|----------|-------------------------|
| B1       | Channel 1 Out (+) | C4       | Voltage Supply (+24VDC) |
| B2       | Channel 1 Out (-) | C5       | Channel 1 In (-)        |
| B3       | Channel 2 Out (+) | C6       | Channel 1 In (+)        |
| B4       | Channel 2 Out (-) | P1       | AC Power (Hot)          |
| C1       | Channel 2 In (-)  | P2       | Not Used                |
| C2       | Channel 2 In (+)  | P3       | Not Used                |
| C3       | Not Connected     | P4       | AC Power (Neutral)      |

## Dimensions

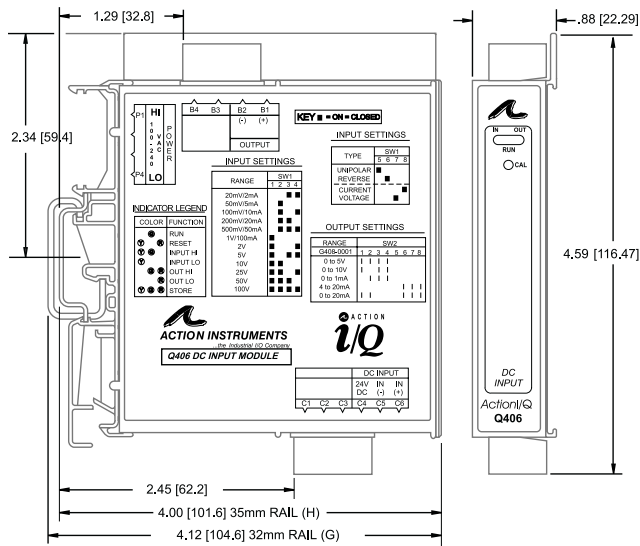

Printed on recycled paper

## Factory Assistance

For additional information on calibration, operation and installation contact our Technical Services Group:

**703-669-1318**

[actionsupport@eurotherm.com](mailto:actionsupport@eurotherm.com)

721-0664-00-1 02/09 Copyright© Eurotherm, Inc 2009

## Eurotherm, Inc

741-F Miller Drive  
Leesburg, VA 20175-8993  
703-443-0000

[info@eurotherm.com](mailto:info@eurotherm.com) or [www.eurotherm.com/actionio](http://www.eurotherm.com/actionio)