

DC Brushless Fan

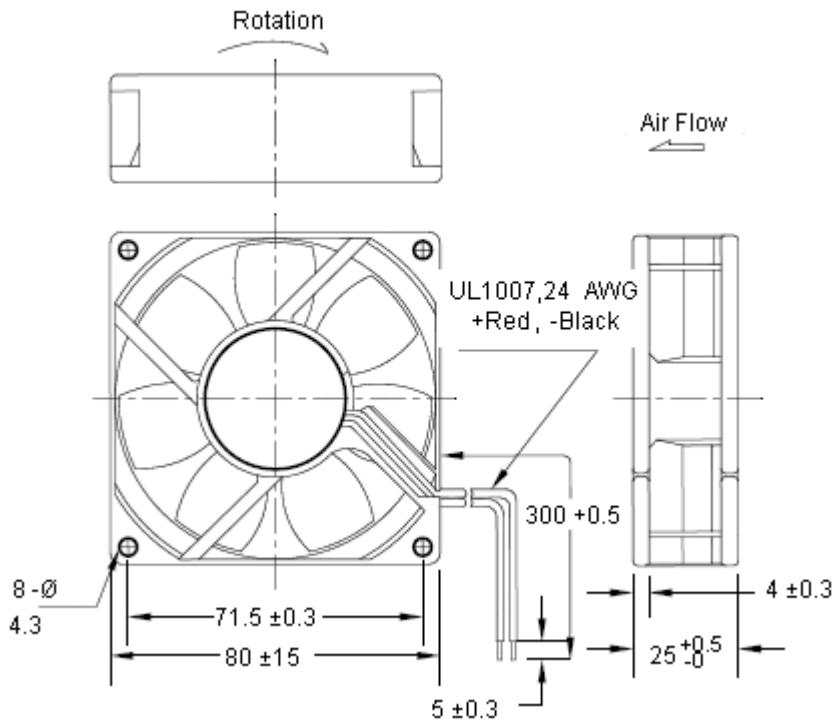

Material:

Frame	: Thermoplastic PBT of UL 94V-0
Impeller	: Thermoplastic PBT of UL 94V-0
Bobbin	: Thermoplastic PBT UL 94V-0
Lead Wire	: UL1007, 24 AWG, +Red, -Black



Dimensions : Millimetres

1. Air flow direction : toward label side
2. Best mounting direction : any orientation

Characteristics:

Motor Design	: DC brushless 4 pole motor design
Insulation Resistance	: More 10 MΩ between internal stator and lead wire (+) measured at 500 V dc
Dielectric Strength	: Applied 500 V ac for one minute or 600 V ac for 2 seconds between housing and lead wire (+)
Noise Level	: Measured in a semi-anechoic chamber with background noise level below 15 dB (A). The fan is running in free air with the microphone at a distance of one meter from the fan intake
Input Power, Current and Speed	: Measured after continuous 10 minute operation at rated voltage in clean air, and at ambient temperature of 25°C
Tolerance	: ±15% on rated power and current
Air Performance	: Measured by a double chamber. The values are recorded when the fan speed has stabilized at rated voltage

DC Brushless Fan



Specifications:

Rated Voltage	: 48 V dc
Operating Voltage Range	: 24 to 56 V dc
Starting Voltage	: 24 V dc (25°C power on / off)
Rated Speed	: 4,700 RPM \pm 10%
Air Delivery	: 60 CFM
Static Pressure	: 0.43 inch-H ₂ O
Rated Current	: 0.13 A
Rated Power	: 6.2 W
Noise Level	: 47 dB (A)
Direction of Rotation	: Counter-Clockwise viewed from of fan blade
Operating Temperature	: -10 to +70°C
Storage Temperature	: -40 to +70°C
Bearing System	: Precision ball bearing system
Weight	: 100 g
Safety	: UL / CUR approvals
Vibration	: Vibration of acceleration 1.5 G and frequency 5 to 50 to 5 Hz is applied in all 3 directions (X,Y,Z), in cycles of 1 minute each, for a total vibration time of 30 minutes
Locked Rotor Protection	: Automatic restart capability Note : In a situation where the fan is locked by an external force while the electricity is on, an increase in coil temperature will be prevented by temporarily turning off the electrical power to the motor. The fan will automatically restart when the locked rotor is condition released

Performance Curves

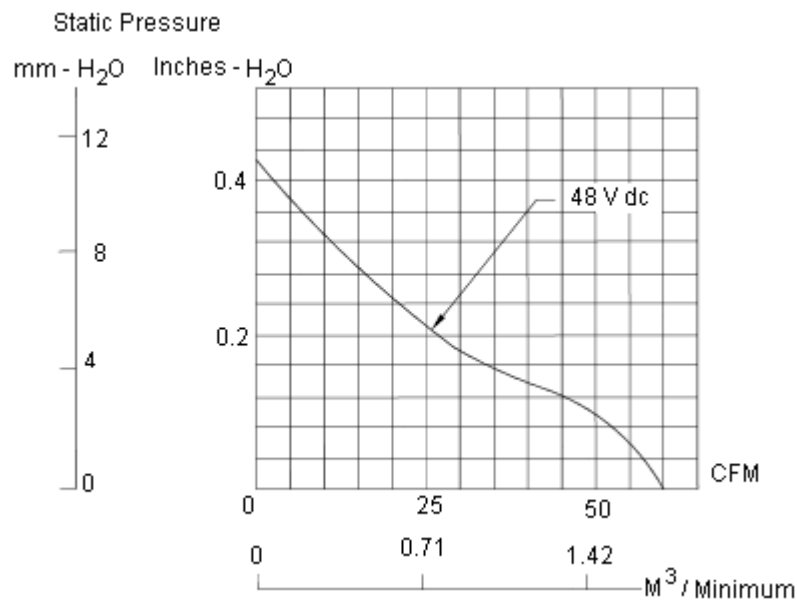

Part Number Table

Description	Part Number
Fan, Axial, 48 DC, 0.13 A, 80 mm	MC21698

Important Notice : This data sheet and its contents (the "Information") belong to the members of the Premier Farnell group of companies (the "Group") or are licensed to it. No licence is granted for the use of it other than for information purposes in connection with the products to which it relates. No licence of any intellectual property rights is granted. The Information is subject to change without notice and replaces all data sheets previously supplied. The Information supplied is believed to be accurate but the Group assumes no responsibility for its accuracy or completeness, any error in or omission from it or for any use made of it. Users of this data sheet should check for themselves the Information and the suitability of the products for their purpose and not make any assumptions based on information included or omitted. Liability for loss or damage resulting from any reliance on the Information or use of it (including liability resulting from negligence or where the Group was aware of the possibility of such loss or damage arising) is excluded. This will not operate to limit or restrict the Group's liability for death or personal injury resulting from its negligence. Multicomp is the registered trademark of the Group. © Premier Farnell plc 2012.