



Address: Midas Components Limited, Electra House, 32 Southdown Road, Great Yarmouth, Norfolk, NR31 0DU  
Telephone: +44 (0)1493 602602  
Fax: +44 (0)1493 665111  
Email: [sales@midascomponents.co.uk](mailto:sales@midascomponents.co.uk)  
Website: [www.midascomponents.co.uk](http://www.midascomponents.co.uk)

# Specification

MCCOG240064C6W-FPTLW

A large, faded version of the MIDAS logo is centered on the page. It consists of the word "MIDAS" in a yellow, sans-serif font, set against a light blue, oval-shaped background with a wavy, textured pattern.

## DOCUMENT REVISION HISTORY

<b>Version</b>	<b>DATE</b>	<b>DESCRIPTION</b>	<b>CHANGED BY</b>
00	Mar-11-2010	First issue	

A large, semi-transparent watermark of the word "MIDAS" in a bold, yellow, serif font is centered across the middle of the page, overlapping the table's description and changed by columns.

## Midas LCD Part Number System

**MC COG 132033 A \* 6 W \* \* - S N T L W \* \***  
 1 2 3 4 5 6 7 8 9 - 10 11 12 13 14 15 16

- 1 = **MC:** Midas Components
- 2 = **Blank:** COB (chip on board) **COG:** chip on glass
- 3 = **No of dots** (e.g. 240064 = 240 x 64 dots) (e.g. 21605 = 2 x 16 5mm C.H.)
- 4 = **Series**
- 5 = **Series Variant:** A to Z – **see addendum**
- 6 = **3:** 3 o'clock **6:** 6 o'clock **9:** 9 o'clock **12:** 12 o'clock
- 7 = **S:** Normal (0 to + 50 deg C) **W:** Wide temp. (-20 to + 70 deg C) **X:** Extended temp (-30 + 80 Deg C)
- 8 = **Character Set**  
**Blank:** Standard (English/Japanese)  
**C:** Chinese Simplified (Graphic Displays only)  
**CB:** Chinese Big 5 (Graphic Displays only)  
**H:** Hebrew  
**K:** European (std) (English/German/French/Greek)  
**L:** English/Japanese (special)  
**M:** European (English/Scandinavian)  
**R:** Cyrillic  
**W:** European (English/Greek)  
**U:** European (English/Scandinavian/Icelandic)
- 9 = **Bezel Height** (where applicable / available)

	Top of Bezel to Top of PCB	Common (via pins 1 and 2)	Array or Edge Lit
<b>Blank</b>	9.5mm / not applicable	Common	Array
<b>2</b>	8.9 mm	Common	Array
<b>3</b>	7.8 mm	Separate	Array
<b>4</b>	7.8 mm	Common	Array
<b>5</b>	9.5 mm	Separate	Array
<b>6</b>	7 mm	Common	Array
<b>7</b>	7 mm	Separate	Array
<b>8</b>	6.4 mm	Common	Edge
<b>9</b>	6.4 mm	Separate	Edge
<b>A</b>	5.5 mm	Common	Edge
<b>B</b>	5.5 mm	Separate	Edge
<b>D</b>	6.0mm	Separate	Edge
<b>E</b>	5.0mm	Separate	Edge
<b>F</b>	4.7mm	Common	Edge
<b>G</b>	3.7mm	Separate	EL

- 10 = **T:** TN **S:** STN **B:** STN Blue **G:** STN Grey **F:** FSTN **F2:** FFSTN
- 11 = **P:** Positive **N:** Negative
- 12 = **R:** Reflective **M:** Transmissive **T:** Transflective
- 13 = **Backlight:** **Blank:** Reflective **L:** LED
- 14 = **Backlight Colour:** **Y:** Yellow-Green **W:** White **B:** Blue **R:** Red **A:** Amber **O:** Orange **G:** Green **RGB:** R.G.B.
- 15 = **Driver Chip:** **Blank:** Standard **I:** I<sup>2</sup>C **T:** Toshiba T6963C **A:** Avant SAP1024B **R:** Raio RA8835
- 16 = **Voltage Variant:** e.g. **3** = 3v

## CONTENTS

<b>1. Functions &amp; Features</b>	<b>2</b>
<b>2. Mechanical specifications</b>	<b>2</b>
<b>3. Block diagram</b>	<b>2</b>
<b>4. Dimensional Outline</b>	<b>3</b>
<b>5. Pin description</b>	<b>4</b>
<b>6. Maximum absolute limit</b>	<b>4</b>
<b>7. Electrical characteristics</b>	<b>5~7</b>
<b>8. Reset Timing</b>	<b>7</b>
<b>9. Control and display command</b>	<b>8</b>
<b>10. Backlight Specification</b>	<b>9</b>
<b>11. Electro-Optical characteristics</b>	<b>9</b>
<b>12. Precaution for using LCD/LCM</b>	<b>10~11</b>
<b>13. LCM test criteria</b>	<b>12~21</b>

## **1. FUNCTIONS & FEATURES**

1.1. Format	: 240x64 dots
1.2. LCD mode	: FSTN /Positive /Transflective
1.3. Viewing direction	: 6 o'clock
1.4. Driving scheme	: 1/96 Duty, 1/10.7 Bias
1.5. Power operation	: 3.3V
1.6. VLCD adjustable for best contrast	: 14.1V(Reference voltage)
1.7. Operation temp	: -20~70°C
1.8. Storage temp	: -30~80°C
1.9. Backlight color	: White
1.10. RoHS standard	

## **2. MECHANICAL SPECIFICATIONS**

2.1. Module size	: 134.6mm(L)*55.1+50.0(FPC length)mm(W)*5.8mm(H)
2.2. Viewing area	: 111.0mm(L)*37.0mm(W)
2.3. Dot pitch	: 0.44mm(L)*0.50mm(W)
2.4. Dot size	: 0.41mm(L)*0.47mm(W)
2.5. Weight	: Approx.

## **3. BLOCK DIAGRAM**

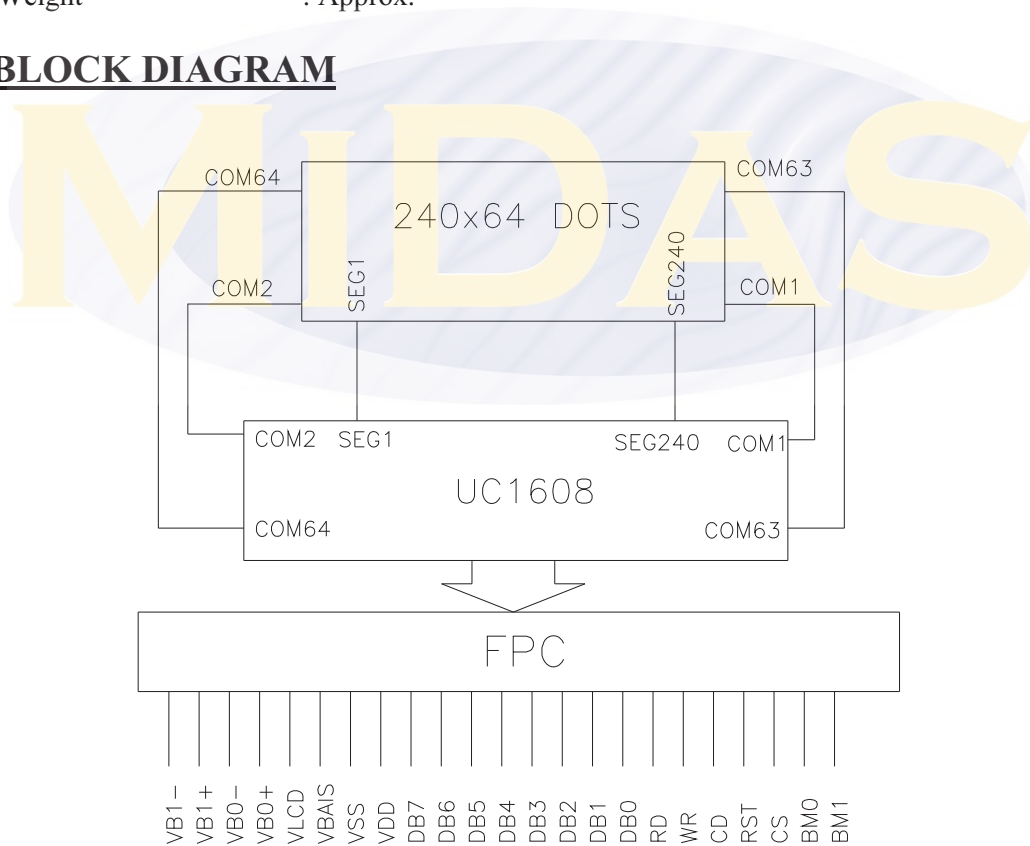

Figure 1. Block diagram

# 4. DIMENSIONAL OUTLINE

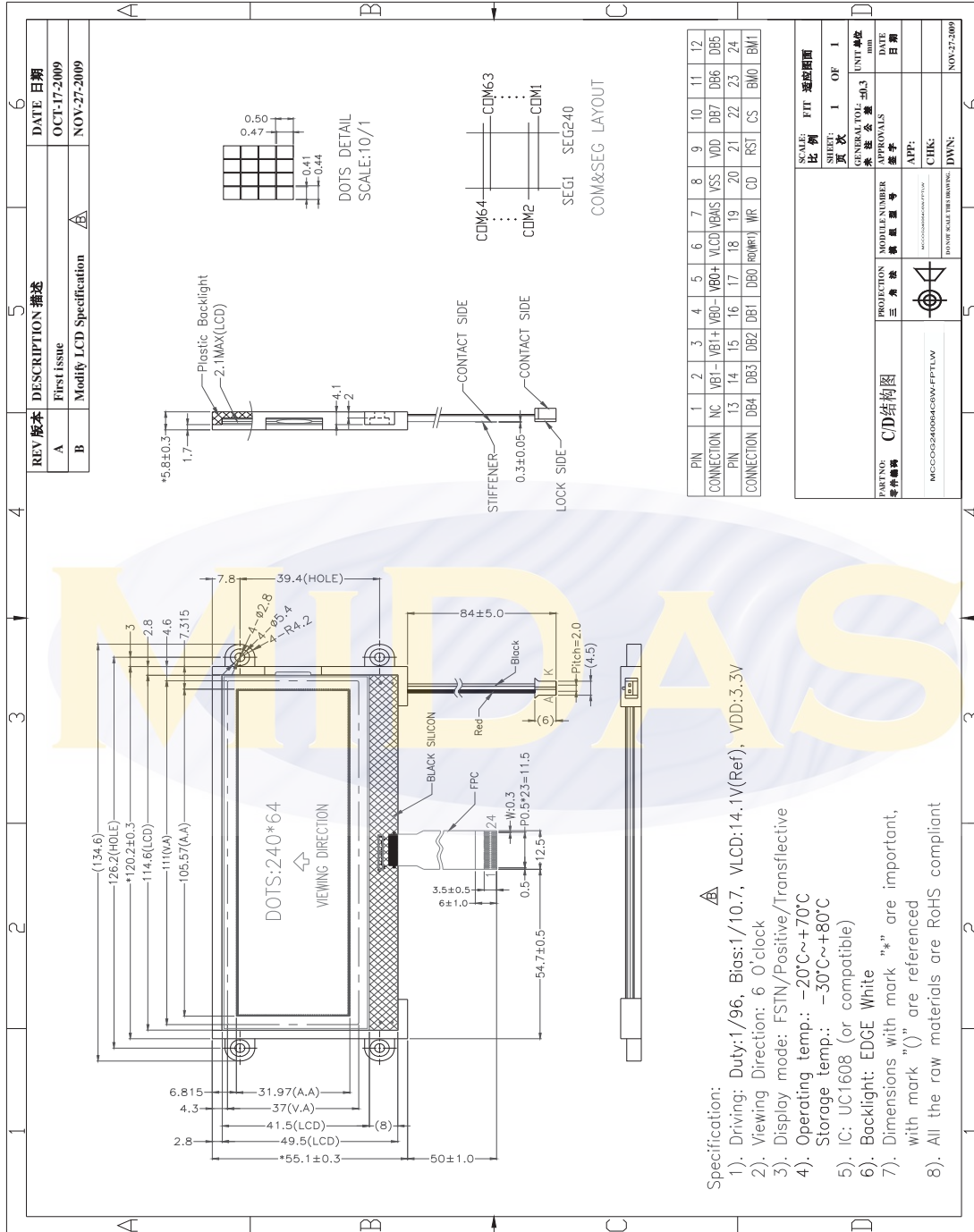

Figure 2. Dimensional outline

## 5. PIN DESCRIPTION

No.	Symbol	Function
1	NC	No connection
2	VB1-	LCD Bias Voltages.
3	VB1+	
4	VB0-	
5	VB0+	
6	VLCD	Main LCD Power Supply.
7	VBAIS	This is the reference voltage to generate the actual SEG driving voltage
8	VSS	Ground(0V)
9	VDD	Power supply for logic (+3.3V)
10~17	DB7~DB0	Bi-directional bus for both serial and parallel host interfaces.
18	RD(WR1)	WR[1:0] controls the read/write operation of the host interface.
19	WR	
20	CD	Select Command or Display Data for read/write operation. "L": Command "H": Display data
21	RST	Reset input pin
22	CS	Chip Select. The chip is selected when CS="H".
23	BM0	Parallel/Serial. 4-bit bus modes: "LL": 8080 "LH": 6800 8-bit bus modes: "HL": 8080 "HH": 6800
24	BM1	

## 6. MAXIMUM ABSOLUTE LIMIT

For IC (UC1608):

Symbol	Parameter	Min.	Max.	Unit
V <sub>DD</sub>	Logic Supply voltage	-0.3	+4.0	V
V <sub>DD2</sub>	LCD Generator Supply voltage	-0.3	+4.0	V
V <sub>DD3</sub>	Analog Circuit Supply voltage	-0.3	+4.0	V
V <sub>LCD</sub>	LCD Generated voltage (-30°C ~ +80°C)	-0.3	+17.0	V
V <sub>IN</sub>	Any input voltage	-0.4	V <sub>DD</sub> + 0.5	V
T <sub>OPR</sub>	Operating temperature range	-30	+85	°C
T <sub>STR</sub>	Storage temperature	-55	+125	°C

### Notes

- VDD based on VSS = 0V
- Stress values listed above may cause permanent damages to the device.

## 7. ELECTRICAL CHARACTERISTICS

### 7.1. DC CHARACTERISTICS

Symbol	Parameter	Conditions	Min.	Typ.	Max.	Unit
$V_{DD}$	Supply for digital circuit		2.4	2.8	3.6	V
$V_{DD2/3}$	Supply for bias & pump		2.4	2.8	3.6	V
$V_{LCD}$	Charge pump output	$V_{DD2/3} \geq 2.4V, 25^{\circ}C$		12.5	15	V
$V_D$	LCD data voltage	$V_{DD2/3} \geq 2.4V, 25^{\circ}C$			1.2	V
$V_{IL}$	Input logic LOW				$0.2V_{DD}$	V
$V_{IH}$	Input logic HIGH		$0.8V_{DD}$			V
$V_{OL}$	Output logic LOW				$0.2V_{DD}$	V
$V_{OH}$	Output logic HIGH		$0.8V_{DD}$			V
$I_{IL}$	Input leakage current				1.5	$\mu A$
$C_{IN}$	Input capacitance			5	10	PF
$C_{OUT}$	Output capacitance			5	10	PF
$R_{O(SEG)}$	SEG output impedance	$V_{LCD} = 12.5V$		1.5	3	$k\Omega$
$R_{O(COM)}$	COM output impedance	$V_{LCD} = 12.5V$		1.5	3	$k\Omega$
$f_{LINE}$	Average frame rate			90		Hz

### 7.2. AC CHARACTERISTICS

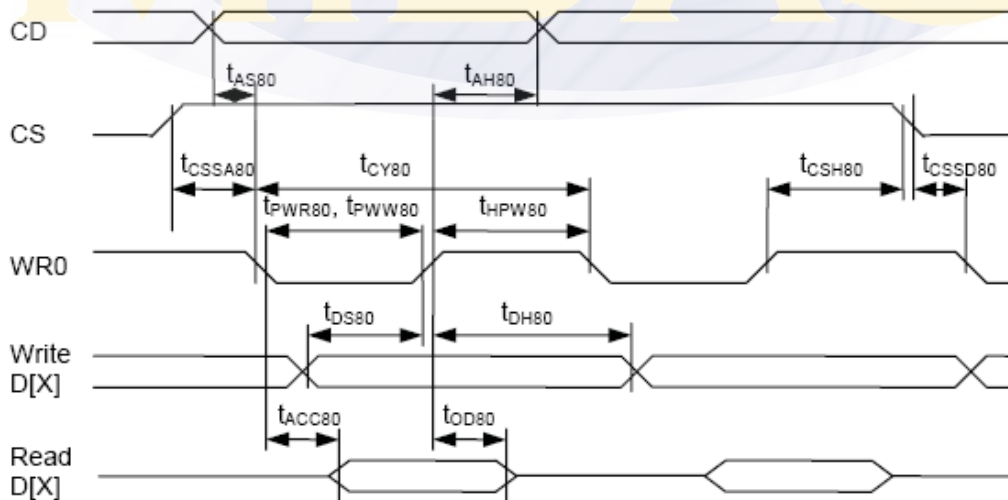

Parallel Bus Timing Characteristics (for 8080 MCU)



(VDD=2.4V to 3.3V, Ta= -30 to +85°C)

Symbol	Signal	Description	Condition	Min.	Max.	Units
$t_{AS80}$ $t_{AH80}$	CD	Address setup time Address hold time		0 10	-	ns
$t_{CY80}$		System cycle time 8 bits bus (read) (write) 4 bits bus (read) (write)		140 140 80 80	-	ns
$t_{PWR80}$	WR1	Pulse width 8 bits (read) 4 bits		65 35	-	ns
$t_{PWW80}$	WR0	Pulse width 8 bits (write) 4 bits		65 35	-	ns
$t_{HPW80}$	WR0, WR1	High pulse width 8 bits bus (read) (write) 4 bits bus (read) (write)		65 65 35 35	-	ns
$t_{DS80}$ $t_{DH80}$	D0~D7	Data setup time Data hold time		30 10	-	ns
$t_{ACC80}$ $t_{OD80}$		Read access time Output disable time	$C_L = 100pF$	- 10	50 50	ns
$t_{CSSA80}$ $t_{CSSD80}$ $t_{CSH80}$	CS	Chip select setup time		10 10 20		ns

### High-Voltage Mixed-Signal IC

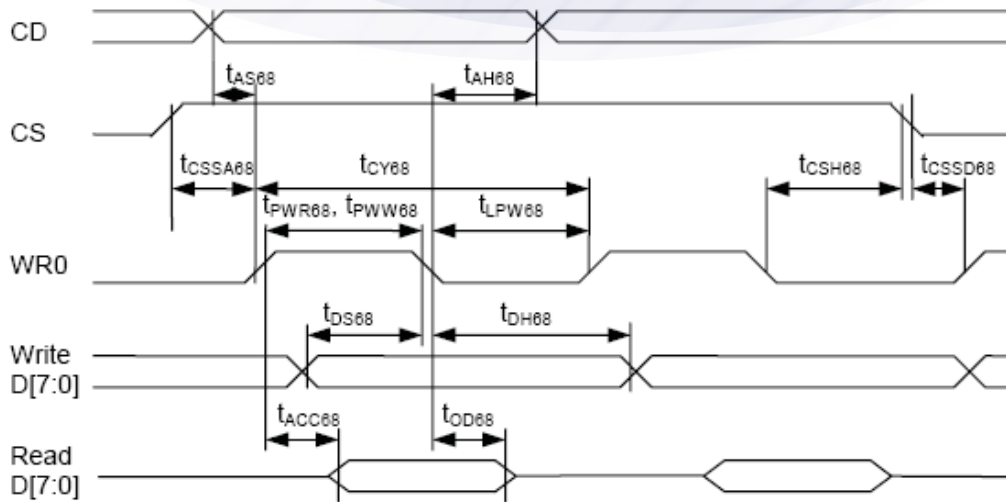

Parallel Bus Timing Characteristics (for 6800 MCU)

(VDD=2.4V to 3.3V, Ta= -30 to +85°C)

Symbol	Signal	Description	Condition	Min.	Max.	Units
$t_{AS08}$ $t_{AH08}$	CD	Address setup time Address hold time		0 10	–	ns
$t_{CY08}$		System cycle time 8 bits bus (read) (write) 4 bits bus (read) (write)		140 140 80 80	–	ns
$t_{PWR08}$	WR1	Pulse width 8 bits (read) 4 bits		65 35	–	ns
$t_{PWW08}$		Pulse width 8 bits (write) 4 bits		65 35	–	ns
$t_{LPW08}$		Low pulse width 8 bits bus (read) (write) 4 bits bus (read) (write)		65 65 35 35	–	ns
$t_{DS08}$ $t_{DH08}$	D0~D7	Data setup time Data hold time		30 10	–	ns
$t_{ACC08}$ $t_{OD08}$		Read access time Output disable time	$C_L = 100\text{pF}$	– 10	50 50	ns
$T_{CSSA08}$ $T_{CSSD08}$ $T_{CSH08}$	CS	Chip select setup time		10 10 20	–	ns

## 8. Reset Timing

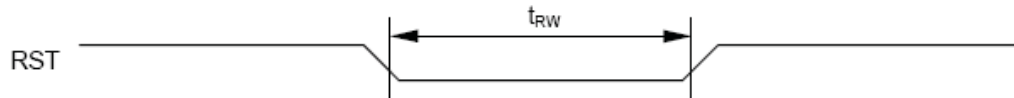

(VDD=2.4V to 3.3V, Ta= -30 to +85°C)

Symbol	Signal	Description	Condition	Min.	Max.	Units
$t_{RW}$	RST	Reset low pulse width		1000	–	ns

## 9. CONTROL AND DISPLAY INSTRUCTION

The following is a list of host commands supported by UC1608

C/D: 0: Control, 1: Data  
W/R: 0: Write Cycle, 1: Read Cycle

# Useful Data bits  
- Don't Care

	Command	C/D	W/R	D7	D6	D5	D4	D3	D2	D1	D0	Action	Default value
1	Write Data Byte	1	0	#	#	#	#	#	#	#	#	Write 1 byte	N/A
2	Read Data Byte	1	1	#	#	#	#	#	#	#	#	Read 1 byte	N/A
3	Get Status	0	1	BZ	MX	DE	RS	WA	GN1	GN0	1	Get Status	N/A
4	Set Column Address LSB	0	0	0	0	0	0	#	#	#	#	Set CA[3:0]	0
	Set Column Address MSB	0	0	0	0	0	1	#	#	#	#	Set CA[7:4]	0
5	Set Mux Rate and temperature compensation.	0	0	0	0	1	0	0	#	#	#	Set {MR, TC[1:0]}	MR: 1 TC: 0
6	Set Power Control	0	0	0	0	1	0	1	#	#	#	Set PC[2:0]	111b
7	Set Adv. Product Config. (double byte command)	0	0	0	0	1	1	0	0	0	R	For UltraChip only. Do not use.	N/A
		0	0	#	#	#	#	#	#	#	#		
8	Set Start Line	0	0	0	1	#	#	#	#	#	#	Set SL[5:0]	0
9	Set Gain and Potentiometer (double-byte command)	0	0	1	0	0	0	0	0	0	1	Set {GN[1:0], PM[5:0]}	GN=3 PM=0
		0	0	#	#	#	#	#	#	#	#		
10	Set RAM Address Control	0	0	1	0	0	0	1	#	#	#	Set AC[2:0]	000b
11	Set All-Pixel-ON	0	0	1	0	1	0	0	1	0	#	Set DC[1]	0=disable
12	Set Inverse Display	0	0	1	0	1	0	0	1	1	#	Set DC[0]	0=disable
13	Set Display Enable	0	0	1	0	1	0	1	1	1	#	Set DC[2]	0=disable
14	Set Page Address	0	0	1	0	1	1	#	#	#	#	Set PA[3:0]	0
15	Set LCD Mapping Control	0	0	1	1	0	0	#	#	#	#	Set LC[3:0]	0
16	System Reset	0	0	1	1	1	0	0	0	1	0	System Reset	N/A
17	NOP	0	0	1	1	1	0	0	0	1	1	No operation	N/A
18	Set LCD Bias Ratio	0	0	1	1	1	0	1	0	#	#	Set BR[1:0]	10b=12
19	Reset Cursor Mode	0	0	1	1	1	0	1	1	1	0	AC[3]=0, CA=CR	N/A
20	Set Cursor Mode	0	0	1	1	1	0	1	1	1	1	AC[3]=1, CR=CA	N/A
21	Set Test Control (double byte command)	0	0	1	1	1	0	0	1	TT		For UltraChip only. Do not use.	N/A
		0	0	#	#	#	#	#	#	#	#		

\* Other than commands listed above, all other bit patterns may result in undefined behavior.

## 10. BACKLIGHT SPECIFICATION

LCD Module with Edge White LED Backlight

**ELECTRICAL RATINGS.** Ta = 25°C

Item	Symbol	Condition	Min	Typ	Max	Unit
Forward Voltage	VF	IF=90mA	2.9	---	3.3	V
Reverse Current	IR	VR=0.8V	---	20	---	mA
Luminous Intensity(Without LCD)	Lv	IF=90mA	350	400	---	cd/m2
Color coordinates	X Y	IF=90mA	0.26 0.26	---	0.30 0.30	
Color	White					

Note:

when the temperature exceed 25°C, the approved current decrease rate for Backlight change as the temperature increase is: -0.36x6mA/°C (below 25°C, the current refer to constant, which would not change with temperature ).

## 11.ELECTRO-OPTICAL CHARACTERISTICS

(V<sub>DD</sub> = 3.3V, Ta = 25°C)

Item	Symbol	Condition	Min	Typ	Max	Unit
Operating Voltage for LCD	Vop	Ta = -20°C	14.2	14.5	14.7	V
		Ta = 25°C	13.8	14.1	14.4	
		Ta = 70°C	13.4	13.7	14.0	
Response time	Tr	Ta = 25°C	---	250	500	ms
	Tf		---	300	600	ms
Contrast	Cr	Ta = 25°C	---	12	---	---
Viewing angle range	θ	Cr ≥ 2	-35	---	+35	deg
	Φ		-35	---	+40	deg

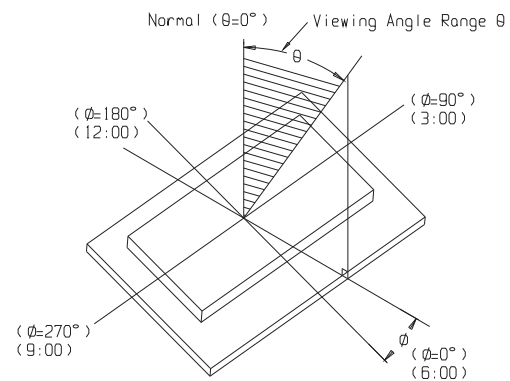
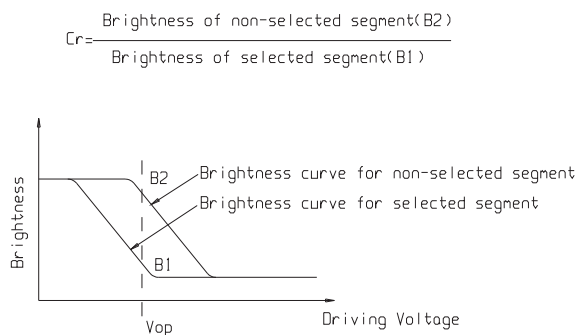

## **12. PRECAUTION FOR USING LCD/LCM**

After reliability test, recovery time should be 24 hours minimum. Moreover, functions, performance and appearance shall be free from remarkable deterioration within 50,000 hours (average) under ordinary operating and storage conditions room temperature ( $20\pm 8^{\circ}\text{C}$ ), normal humidity (below 65% RH), and in the area not exposed to direct sun light. Using LCM beyond these conditions will shorten the life time.

### Precaution for using LCD/LCM

LCD/LCM is assembled and adjusted with a high degree of precision. Do not attempt to make any alteration or modification. The followings should be noted.

#### **General Precautions:**

1. LCD panel is made of glass. Avoid excessive mechanical shock or applying strong pressure onto the surface of display area.
2. The polarizer used on the display surface is easily scratched and damaged. Extreme care should be taken when handling. To clean dust or dirt off the display surface, wipe gently with cotton, or other soft material soaked with isopropyl alcohol, ethyl alcohol or trichlorotrifluoroethane, do not use water, ketone or aromatics and never scrub hard.
3. Do not tamper in any way with the tabs on the metal frame.
4. Do not make any modification on the PCB without consulting Midas.
5. When mounting a LCM, make sure that the PCB is not under any stress such as bending or twisting. Elastomer contacts are very delicate and missing pixels could result from slight dislocation of any of the elements.
6. Avoid pressing on the metal bezel, otherwise the elastomer connector could be deformed and lose contact, resulting in missing pixels and also cause rainbow on the display.
7. Be careful not to touch or swallow liquid crystal that might leak from a damaged cell. Any liquid crystal adheres to skin or clothes, wash it off immediately with soap and water.

#### **Static Electricity Precautions:**

1. CMOS-LSI is used for the module circuit; therefore operators should be grounded whenever he/she comes into contact with the module.
2. Do not touch any of the conductive parts such as the LSI pads; the copper leads on the PCB and the interface terminals with any parts of the human body.
3. Do not touch the connection terminals of the display with bare hand; it will cause disconnection or defective insulation of terminals.
4. The modules should be kept in anti-static bags or other containers resistant to static for storage.
5. Only properly grounded soldering irons should be used.

6. If an electric screwdriver is used, it should be grounded and shielded to prevent sparks.
7. The normal static prevention measures should be observed for work clothes and working benches.
8. Since dry air is inductive to static, a relative humidity of 50-60% is recommended.

#### **Soldering Precautions:**

1. Soldering should be performed only on the I/O terminals.
2. Use soldering irons with proper grounding and no leakage.
3. Soldering temperature:  $350^{\circ}\text{C}\pm 10^{\circ}\text{C}$
4. Soldering time: 3 to 4 second.
5. Use eutectic solder with resin flux filling.
6. If flux is used, the LCD surface should be protected to avoid spattering flux.
7. Flux residue should be removed.

#### **Operation Precautions:**

1. The viewing angle can be adjusted by varying the LCD driving voltage  $V_o$ .
2. Since applied DC voltage causes electro-chemical reactions, which deteriorate the display, the applied pulse waveform should be a symmetric waveform such that no DC component remains. Be sure to use the specified operating voltage.
3. Driving voltage should be kept within specified range; excess voltage will shorten display life.
4. Response time increases with decrease in temperature.
5. Display color may be affected at temperatures above its operational range.
6. Keep the temperature within the specified range usage and storage. Excessive temperature and humidity could cause polarization degradation, polarizer peel-off or generate bubbles.
7. For long-term storage over  $40^{\circ}\text{C}$  is required, the relative humidity should be kept below 60%, and avoid direct sunlight.

#### **Limited Warranty**

MidasLCDs and modules are not consumer products, but may be incorporated by Midas' customers into consumer products or components thereof, Midas does not warrant that its LCDs and components are fit for any such particular purpose.

1. The liability of Midas is limited to repair or replacement on the terms set forth below. Midas will not be responsible for any subsequent or consequential events or injury or damage to any personnel or user including third party personnel and/or user. Unless otherwise agreed in writing between Midas and the customer, Midas will only replace or repair any of its LCD which is found defective electrically or visually when inspected in accordance with Midas general LCD inspection standard . (Copies available on request)
2. No warranty can be granted if any of the precautions state in handling liquid crystal display above has been disregarded. Broken glass, scratches on polarizer mechanical damages as well as defects that are caused accelerated environment tests are excluded from warranty.
3. In returning the LCD/LCM, they must be properly packaged; there should be detailed description of the failures or defect.

## **13. LCM test criteria**

### **1. Objective**

The criteria is applied for consolidating the LCM quality standard between Midas and customer in finished products acceptance inspection and shipment, to guarantee the products quality to meet with customer's demand.

### **2. Scope**

2.1 This criteria is applicable to all the LCM products produced by Midas.

### **3. Inspection equipment**

Function Tester、 Vernier Calipers、 Microscope、 Magnifier、 ESD Wrist Strap、 Finger Cover、 Labels、 High-Low Temperature Oven、 Refrigerator、 Constant Voltage Power Supply ( DC ) , Desk Lamp, etc.

### **4. Sampling Plan and Reference Standard**

4.1.1 According to GB/T 2828.1---2003/ISO2859-1:1999, single sampling under normal inspection, general inspection level II.

Item of Inspection	Times of Sampling	AQL Judgment
Cosmetic	II Single Sampling	MA=0.4 MI=1.5
Mechanical	N=3	C=0
Functional	II Single Sampling	MA=0.4 MI=1.5

4.1.2 GB/T 2828.1---2003/ISO2859-1:1999 Counting and sampling procedures and sampling table for Batch-to-Batch Inspection.

4.1.3 GB/T 1619.96 Test method for TN LCD.

4.1.4 GB/T 12848.91 General Specification for STN LCD.

4.1.5 GB2421-89 Basic Environmental Test Procedures for Electrical and Electronic Products

4.1.6 IPC-A-610C Acceptance Condition for Electrical Assemblies.

### **5. Inspection Condition and Inspection Reference**

5.1 The ambient temperature and humidity are  $25 \pm 5^{\circ}\text{C}$  and  $45 \pm 20\%\text{RH}$  respectively, and the ambient luminance should be more than  $300\text{cd}/\text{cm}^2$ . The distance between inspector's eyes and the LCD panel should be 30cm away. Normally we inspect products with reflected light, when we inspect the LCD produces with backlight turned on, the ambient luminance should be less than  $100\text{cd}/\text{cm}^2$ .

5.2 The LCD should be test with  $45^{\circ}$  both left and right side,  $0-45^{\circ}$  both upside

and downside (if for STN product,  $-20-55^{\circ}$  is needed) .

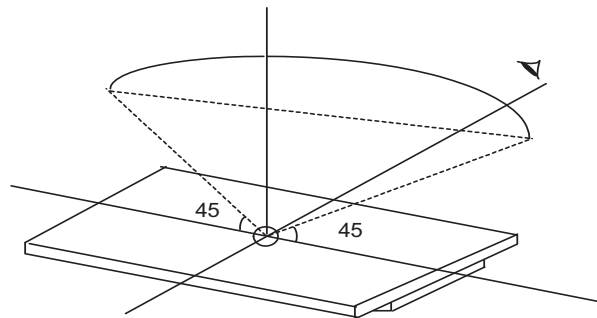

### 5.3 Definition of VA

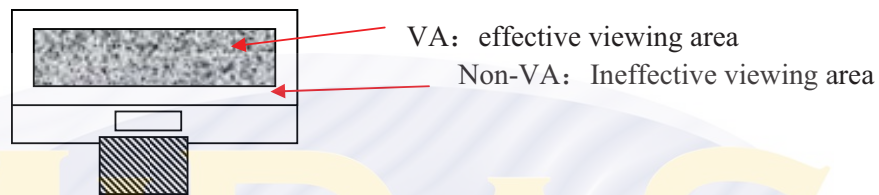

5.4 Inspection with viewed eyes (not including defect size measure by magnifiers) .

### 5.5 Electrical property

Inspect with the test jig to meet with the requirement indicated in the approved documents, including the pattern design and the display performance.

#### 5.5.1 Testing voltage (V)

5.5.1.1 According to the inspection of test jig and production specification the test voltage setting is  $V_{op} \pm 0.3V$  when the  $V_{op}$  is under  $9.0V$ , and  $V_{op} \pm 3\%V_{op}$  when the  $V_{op}$  is above  $9.0V$ .

5.5.1.2 As per the product with the fixed voltage the test voltage setting is same as  $V_{op}$  and keeps the constant voltage through the internal circuit. And the limited sample on the voltage range is needed if necessary.



5.5.2 Current Consumption (I) : refer to product document and approval drawing to confirm it.

## 6. Inspection Item and Acceptance Standard

6.1 Outer dimension: For the outer dimension and the sizes which could influence the assembly at the customer's side, it should be in accordance to the approval drawing, and it belongs to the major defect.

6.2 Functional Test:



No.	Item	Description	MAJ	MIN	Accept standard
6.2.1	Missing Segment	Any missing segment caused by an open circuit; Any missing COM, pattern, dot or segment caused by an open circuit or poor crossover contact 	✓		Rejected
6.2.3	No display/no action	No segment is displayed when the product is connected correctly.	✓		Rejected
6.2.4	Display error/abnormal	The display pattern and display order is not as required under the normal scanning procedure.	✓		Rejected
6.2.5	Viewing angle wrong	The direction with the best display of patterns should be as customer required (or refer to the approval samples)	✓		Rejected
6.2.6	Display dim/dark	The contrast of LCD is too dark or too dim under normal operation	✓		Beyond the voltage tolerance, Rejected
6.2.7	Slow response	Response of some segments is different with others when turned on or off the LCD	✓		Rejected
6.2.8	Extra segment	Display of wiring, or extra pattern, caused by wrong alignment or insufficient corrosion..		✓	refer to spot/line standard
6.2.9	Dim segment	Under the normal voltage, the contrast of segment are uneven		✓	Reject or refer to samples
6.2.10	PI black/white spot	Partial black and white spot are visible while changing display content due to the PI layer defective		✓	refer to the spot/line criteria for the visible spots when display image stopped, others O
6.2.11	pinhole/white spot	The phenomena of missing patterns when turned on caused by missing of ITO fragment.  $d = (X+Y)/2$		✓	refer to spot/line standard

6.2.12	Pattern distortion	Width of pattern displayed is wider , narrower or deformed from the specifications caused by wrong alignment, i.e. extra heave or missing: $ Ia-Ib  \leq 1/4W$ (W is the normal width)		✓	Acceptable $ Ia-Ib  > 1/4W$ , rejected
6.2.13	High current	the current is bigger than regulated value.		✓	Rejected

### 6.3 LCD Visual Defect

#### 6.3.1 Dot defect(defined within VA, out of VA spots not accounted)

Defect item	Average diameter (d)	Accept numbers	MAJ	MIN
Spot defect (black spot, foreign material, nick, scratches, LC defect)	$d \leq 0.2$	3		✓
	$0.2 < d \leq 0.25$	2		
	$0.25 < d \leq 0.30$	1		

#### 6.3.2 Line defect(defined within VA, out of VA spots not accounted)

Defective item	length(L)	width(W)	Accept numbers	MAJ	MIN
line defect (scratch, liner foreign material) 	$\leq 5.0$	$\leq 0.02$	3		✓
	$\leq 3.0$	$\leq 0.03$	3		
	$\leq 3.0$	$\leq 0.05$	1		

note: 1. If the width is bigger than 0.1mm, it can be treated as spot defect.

#### 6.3.3 Polarizer Air Bubble (defined within VA, out of VA spots not accounted)

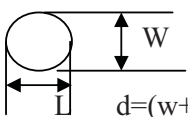
Defective item	Average diameter (d)	Accept numbers	MAJ	MIN
polarizer Air Bubble、Concave-Convex Dot 	$d \leq 0.3$	3		✓
	$0.3 < d \leq 0.5$	2		
	$0.5 < d \leq 0.8$	1		

#### 6.3.4 Damaged(For the products with LCD edge expose to outside without mental frame, including products in COG, with H/S or assembled with backlight)

No.	Item	Acceptance Standard	MAJ	MIN
-----	------	---------------------	-----	-----

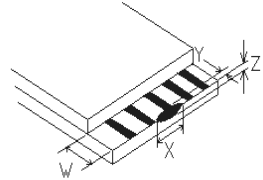
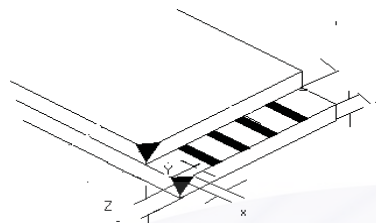
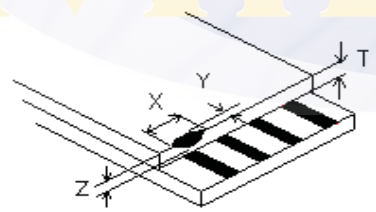
6.3.4.1			(mm)		√
		X	≤1/8L		
		Y	≤1/3W		
		Z	≤1/2t		
		Accept number	2		
When Y ≤ 0.2mm, neglect the length of X, chip on the side without lead, and not perforated, when X ≤ 1/10L, Y ≤ 1/2W max, accept.					
6.3.4.2			(mm)	MAJ	MIN
		X	Not enter into frame epoxy and touch the lead		√
		Y			
		Z	≤t		
Accept numbers	2				
Chips on corner refer to 6.3.4.3 and must be out of the frame epoxy. If chips on lead, refer to 6.3.4.1					
6.3.4.3			(mm)	MAJ	MIN
		X	≤1/8 L		√
		Y	≤1/2H		
		z	≤1/2t		
		Accept numbers	2		
The standard for inner chip on sealed area is same as the standard for outer. If chip on the opposite side of ITO lead, the value Y refer to 6.3.4.1 for the chip on the side without lead.					
note: t---glass thickness, L---length, H---The distance between the LCD edge to the inner of LCD frame epoxy. W---The width of ITO lead					

### 6.3.5 Others

No.	Item	Description	MAJ	MIN	Accept standard
6.3.5.1	Newton/B/G color uniformity not good	There exists more than one color on one product or same batch.		√	Reject or refer to limited sample
6.3.5.2	Leakage(LC)	/	√		Rejected
6.3.5.3	No	/		√	Rejected

	protective film				
--	-----------------	--	--	--	--

6.4 Backlight components

No.	Item	Description	MAJ	MIN	Accept standard
6.4.1	Backlight not work, wrong color	/	√		Rejected
6.4.2	Color deviation	Turn backlight, the color differ from the sample, do not match the drawing after testing		√	Refer to sample and drawing
6.4.3	Brightness deviation	Turn on backlight, the brightness is differ from the sample, or do not match the drawing after testing, or over $\pm 30\%$ compare with sample if drawing not specified.		√	Refer to sample and drawing
6.4.4	Uneven brightness	Turn on the backlight, the brightness is uneven on the same LED and beyond the specification of drawing.		√	Refer to sample and drawing
6.4.5	Spot/line scratch	There is stain, scratches on backlight when turn on.		√	Refer to 6.3.1/6.3.2

6.5 Mental frame

No.	Item	Description	MAJ	MIN	Accept standard
6.5.1	material/surface	Mental frame/surface approach inconsistent with specification.	√		Rejected
6.5.2	Twist not qualified/without twisting	Twist method/direction wrong, not twist as required	√		Rejected
6.5.3	Oxidized steak, paint stripped, color changed, dented mark, scratches	1.Oxidized steak on the surface of the metal frame;2. front surface paint scratch to substrate, the stripped spot $\leq 0.8\text{mm}$ and exceed 3 areas;3.line defect in length $\leq 5.0\text{mm}$ and width $\leq 0.05\text{mm}$ exceed 2 areas, front dent, bubble and side surface have paint stripping to substrate $\leq 1.0\text{mm}$ exceed 3 areas, line defect in width $\leq 0.05\text{mm}$ exceed 3 areas.		√	Rejected
6.5.4	Burred	Burr is too long, enter into viewing area		√	Rejected

6.6 PCB/COB

No.	Item	Description	MAJ	MIN	Accept standard
-----	------	-------------	-----	-----	-----------------

6.6.1	Epoxy Cover Improper	<ol style="list-style-type: none"> <li>1. The Pad within the round white mark is exposed to outside.</li> <li>2. The height of epoxy covers beyond document /drawing specification.</li> <li>3. The epoxy should be covered within the white round mark and the maximum overage is 2mm more than the radius of white mark.</li> <li>4. Clear liner mark on COB surface or pinhole that it is possible to penetrate through the epoxy to chip.</li> <li>5. The pinhole diameter over 0.25mm or other material on COB surface.</li> </ol>		√	Rejected
6.6.2	PCB cosmetic defect	<ol style="list-style-type: none"> <li>1. PCB pad surface can not be oxidized or contaminated.</li> <li>2. PCB can not appear bubbles after through the reflow oven.</li> <li>3. Copper lead due to the PCB green oil drop or scratches. If repaired by adding the green oil, circuit diameter <math>\Phi</math> can not over 1.3mm, other diameter <math>\Phi</math> can not over 2.6mm, total less than 10 areas. Otherwise reject.</li> </ol>		√	Rejected
6.6.3	Components error	<ol style="list-style-type: none"> <li>1. PCB components inconsistent with drawing. Wrong components, more or less pa, polar reverse (The bias circuit of LCD voltage or BL limit current value adjustment is not controlled if not special specified.)</li> <li>2. The JUMP short of PCB should be consistent of the mechanical drawing.</li> <li>3. The components is specially required by the customers and specified in mechanical drawing / technical documents, the components specification should be conformed to technique demand. Otherwise rejected</li> </ol>		√	Rejected

6.7 SMT part (Refer to IPC-A-610C if not specified)

No.	Item	Description	MAJ	MIN	Accept standard
6.7.1	Soldering defect	Cold soldering, false solder, missing solder, tin crack, tin un-dissolved happened with soldering.		√	Rejected
6.7.2	Solder	Solder ball/tin dross drop lead to solder		√	Rejected

	ball/splash	short.			
6.7.3	DIP parts	DIP parts, keypad, connection appear floating and tilted.		√	Rejected
6.7.4	Spot weld shape	The spot weld should be inner dent, can not form to cover solder or less solder or icicle, otherwise reject		√	Rejected
6.7.5	Component foot exposed	For the DIP type components, after soldered, 0.5~2mm component foot must be remained, and should not damage the solder surface nor fully covered the component foot. Otherwise rejected.		√	Rejected
6.7.6	Appearance poor	After soldering, the solder residues appear brown or black. PCB solder spot remained white mist residues after clean.		√	Rejected

6.8 Heating pressure part (including H/S, FPC, etc.)

No.	Item	Description	MAJ	MIN	Accept standard
6.8.1	Out of specification		√		Rejected
6.8.2	Size/position	The size of heating material should be within the specification of the drawing, the contact area of conducted material should be attached more than 1/2 of the body (ITO, PDA, etc)		√	Acceptable
6.8.3	Heat pressure dirty	The obstacle existed in non-conductive heating area and not lead to short, or existed in conductive area but the obstacle is less than 50% of pressure area, it is acceptable.		√	Acceptable
6.8.4	Folding defect			√	Refer to limited sample

6.9 Connector and other parts

No.	Item	Description	MAJ	MIN	Accept standard
6.9.1	Specification improper	The specification of connector and other components do not conform to the drawing as required.	√		Rejected
6.9.2	Position and order	Solder position and Pin 1 should be consistent with the drawing.		√	Rejected

6.9.3	Cosmetic	1. The body of outer component and the PIN has flux. 2. The deformation bigger of PIN connector is bigger than 1/2 of PIN width.		√	Rejected
-------	----------	---	--	---	----------

6.10 General cosmetic

No.	Item	Description	MAJ	MIN	Accept standard
6.10.1	Connection material	Copper lead on FPC pad or the pin terminal of H/S, FFC and damaged. FPC,FFC, COF,H/S connected material curved (except for original) . FPC、PCB pad is bigger than 1PIN width. FPC/FFC material segment, crease exceed the specification.		√	Rejected
6.10.2	Stiffing type defect	Stiffening tape is not covered or fully covered the product's circuit needs to be protected. (Like H/S, FFC, FPC) or cover to the output pin.		√	Rejected
6.10.3	Visual dirty	Dirty on surface of finished products, residual glue, solder spatter or solder ball remain on non-soldered area of PCB/COB. The defective mark or label on product does not remove.		√	Rejected
6.10.4	Assembly black spot	The spot or black dots found after assembly the products with backlight or diffuser.		√	Refer to 6.3.1
6.10.5	Product mark	Part number and batch mark is not conformed with the technical requirement and position, not clear or without mark.		√	Rejected
6.10.6	Inner packing	Packing is inconsistent with requirement, short or over load, Packing is inconsistent with shipment mark/ order demand.		√	Rejected

## 7. Reality test

Note: ①The customer should inform the special requirements on the reliability test to Midas when

Test item	Condition	Time(hrs)	Accept standard
High Temp Storage	80°C	120	No abnormalities in functions and appearance
High Temp Operating	70°C	120	
Low Temp Storage	-30°C	120	
Low Temp Operating	-20°C	120	
Temp& Humidity Test	40°C/90%RH	120	
Temp Shock	-20°C ← 25°C → +70°C (30 min ← 5 min → 30min)	10 cycles	

starting the project.

②For high/low temperature test under both storage and operating condition, the temperature is referer to the product specification.

③For temperature test  $\pm 5^{\circ}\text{C}$  deviation could be accepted.

## 8. Packing

8.1 Product packing must meet the requirement of packing design. The label should be qualified by QA department and it includes the Item No., specification sheet, quantity and production date. Incomplete or mistake is regarded as not qualified.

8.2 When the safety of the packing exist the problems, including shock resistance, moisture resistance, anti-ESD and press resistance, it is regarded as not qualified.

8.3 When customer has special requirement on packing, which is confirmed and accepted by Midas, inspect and release the products as customer required.

8.4 For RoHS or non-RoHS products it should be distinguished with obvious label. Currently we adopt the “RoHS” label for all the products meet the RoHS compliance, or using the labels / marks as the customer required.

## 9. Others

9.1 For unregulated and compromised items, reference shall be taken to mutual agreements and limit samples.