



Address: Midas Components Limited, Electra House, 32 Southdown Road, Great Yarmouth, Norfolk, NR31 0DU
Telephone: +44 (0)1493 602602
Fax: +44 (0)1493 665111
Email: sales@midascomponents.co.uk
Website: www.midascomponents.co.uk

Specification

MCT043G6TW480272LMMLC

A large, faded version of the MIDAS logo is centered on the page. It consists of the word "MIDAS" in a yellow, sans-serif font, set within a light blue oval with a wavy, textured background.

DOCUMENT REVISION HISTORY

VERSION	DATE	DESCRIPTION	CHANGED BY
00	9-28-2010	First issue	Paul
01	12-20-2010	Add 16 data port	Paul

A large, semi-transparent watermark of the word "MIDAS" in a bold, yellow, sans-serif font is centered across the middle of the page, overlapping the table and the rest of the document.

CONTENTS

1	Functions Features	4
2	Mechanical Specifications	4
3	Outline Drawing	5
4	PIN Description	6
5	Electrical Characteristics	6
6	Electro-optical Characteristics	7
7	Control Instruction	8
7.1	Instruction	8
7.2	8080 mode write cycle	8
8	Reliability of LCM	9
9	Application Example	9
10	Program initialization Example	10
10.1	M7_BUS.H File	10
10.2	M7_BUS.C File	14
11	Package Specification	22

Summary

This product is the TFT interface control module 8080

User can choose 8-bit data bus and 16-bit data bus work from different interfaces CON1, CON2

You can choose the color mode for the 565 format 16-bit color input (only support 16-bit data bus input), 24-bit color (8-bits, 16-bit data bus input), according to the initialization parameters of different configuration options (specific settings please refer to M7_Bus.h)

Interface	Cycle	D[23]	D[22]	D[21]	D[20]	D[19]	D[18]	D[17]	D[16]	D[15]	D[14]	D[13]	D[12]	D[11]	D[10]	D[9]	D[8]	D[7]	D[6]	D[5]	D[4]	D[3]	D[2]	D[1]	D[0]
16 bits (565 format)	1 st									R5	R4	R3	R2	R1	G5	G4	G3	G2	G1	G0	B5	B4	B3	B2	B1
16 bits	1 st									R5	R4	R3	R2	R1	R0	X	X	G5	G4	G3	G2	G1	G0	X	X
	2 nd									B5	B4	B3	B2	B1	B0	X	X	R5	R4	R3	R2	R1	R0	X	X
	3 rd									G5	G4	G3	G2	G1	G0	X	X	B5	B4	B3	B2	B1	B0	X	X
8 bits	1 st																	R5	R4	R3	R2	R1	R0	X	X
	2 nd																	G5	G4	G3	G2	G1	G0	X	X
	3 rd																	B5	B4	B3	B2	B1	B0	X	X

1. Functions & Features

- 1.1. Format : 480*272Dots
- 1.2. LCD mode : Transmissive
- 1.3. Viewing direction : 6 O'clock
- 1.4. Display color : Up to 1670K color
- 1.5. Operation temp : -20--70°C
- 1.6. Storage temp : -30--80°C
- 1.7. Power supply voltage (VDD) : 5.0V
- 1.9. Backlight color : White(LED)
- 1.8 LCM Contrast ratio : 500:1
- 1.9 LCM Birghtness : 260cd/m²(type)
- 1.10.RoHS standard
- 1.11.LCM work in 8080 Mode

2. Mechanical Specifications

- 2.1. Module size : 122.0mm(L)*75.0mm(W)*16.0max mm (H)
- 2.2. Viewing area : 97.6mm(L)*57.0mm(W)
- 2.3. Dot pitch : 0.198(W)*0.198(H) mm
- 2.4. Weight : Approx.

3. Outline Drawing

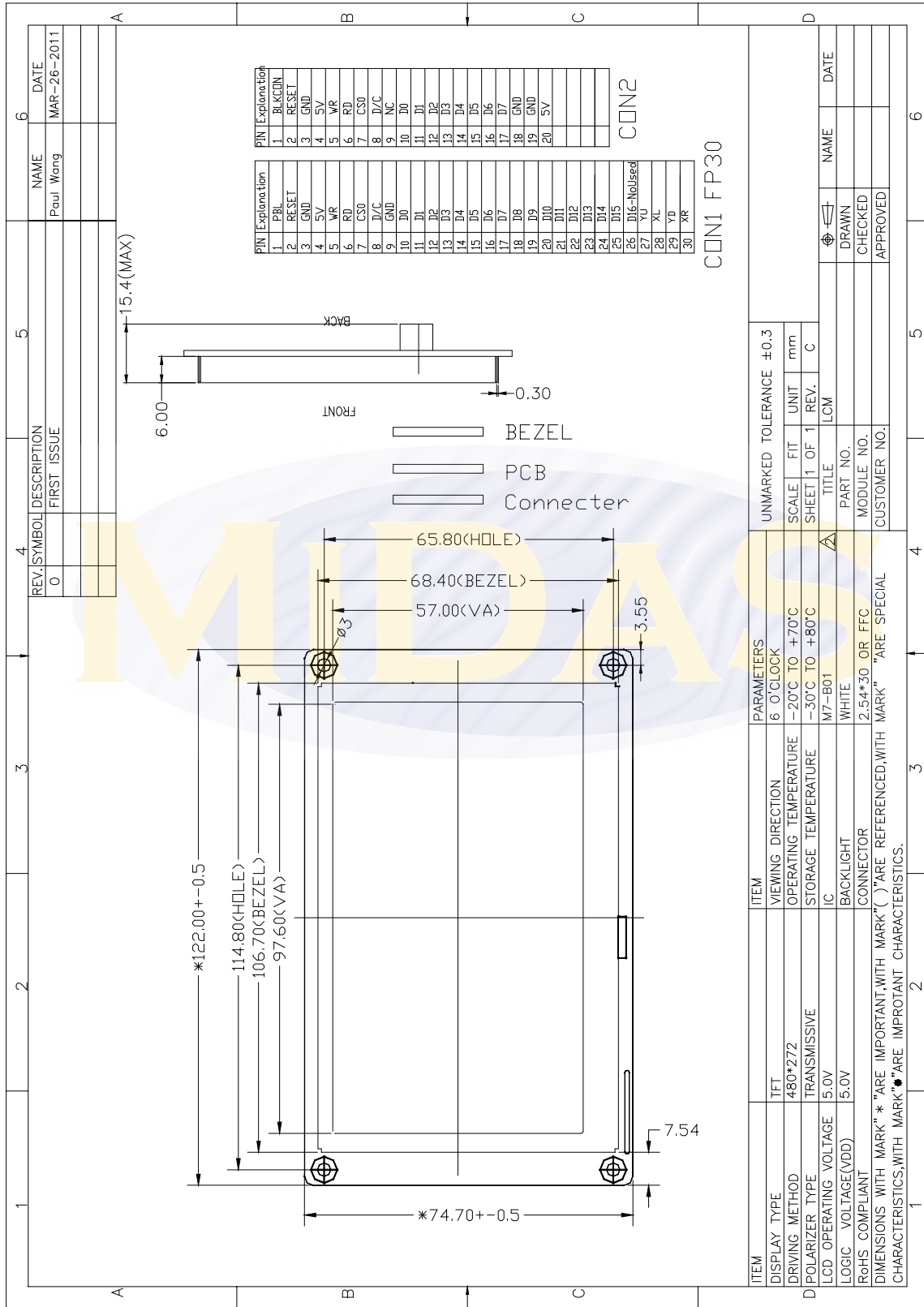

4. PIN Description

(1) CON2

No.	Symbol	Function
1	PBL	BackLight Control.(H: BackLight On, L: BackLight Off)
2	RESET	RESET
3,18,19	GND	GND
4,20	5V	POWER Supply
5	/WR	TFT Write Signal(Low Active)
6	/RD	TFT Read Signal(Low Active)
7	/CS0	TFT Control Chip enable signal
8	D/C	TFT Data Or Command selection(H:Data L: Command)
9	NC	No USE
10-17	DB0-DB7	Data bus line (TFT)

(2) CON1 FP30

No.	Symbol	Function
1	PBL	BackLight Control.(H: BackLight On, L: BackLight Off)
2	RESET	RESET
3	GND	GND
4	5V	POWER Supply
5	/WR	TFT Write Signal(Low Active)
6	/RD	TFT Read Signal(Low Active)
7	/CS0	TFT Control Chip enable signal
8	D/C	TFT Data Or Command selection(H:Data L: Command)
9	GND	GND
10-26	DB0-DB16	The parallel MCU interface (TFT) (DB16 No Used)

5. Electrical Characteristics

Item	Symbol	MIN	MAX	Unit
Supply Voltage for Logic	VDD	4.8	5.0	V
Supply Current		140	160	mA

6. Electro-optical Characteristics

(VDD=3.3V, Vled=5.0V, Ta = 25°C)

Item	Symbol	Condition	Min	Typ	Max	Unit
Viewing angle (CP 10)	0L	=180(9 o'clock)	60	70	---	degree
	0P	=00(3 o'clock)	60	70	---	
	0T	=90(12 o'clock)	40	50	---	
	0B	=270(6 o'clock)	60	70	---	
Response time	Ton	Normal 0=00	---	10	20	ms
	Toff		---	15	30	ms
Contrast ratio	Cr		450	500	---	---
Luminance	L1		150	250		Cd/m2

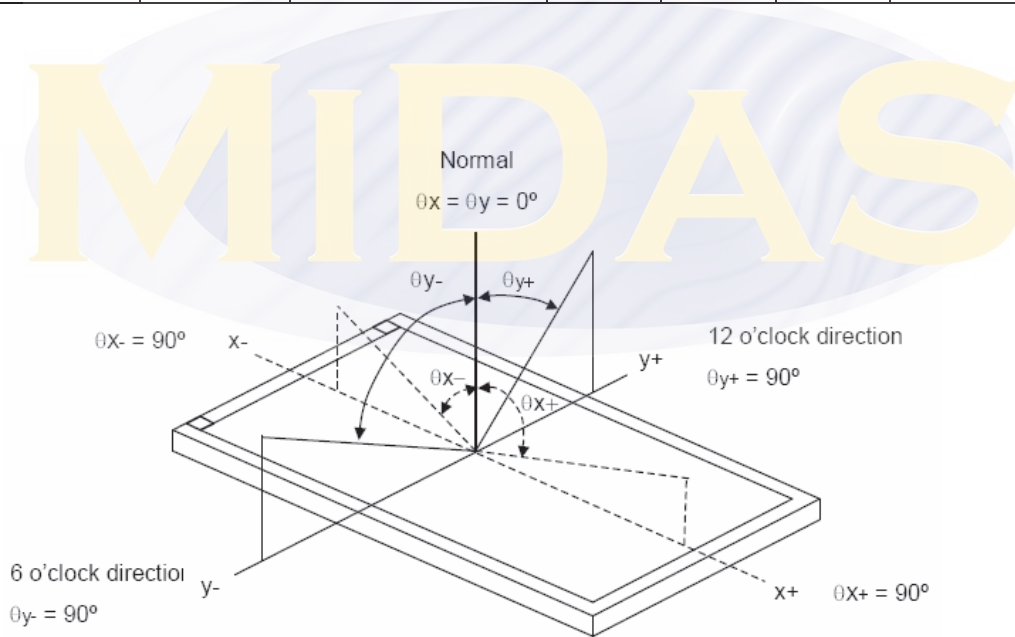

7. Control Instruction

7.1 Instruction

Table : Instruction

/CS0	D/C	/WR	/RD	DB0=DB7
H	H/L	H/L	H/L	Command non-active
L	L	L	H	Write Data
L	H	L	H	Write Command (Used DB0=DB7)
L	L	H	L	Command non-active
L	H	H	L	Read Data

7.2 8080 Mode Write Cycle

Table : 8080 Mode Timing

Symbol	Parameter	Min	Typ	Max	Unit
t _{cyc}	Reference Clock Cycle Time	9	-	-	ns
t _{PWCSL}	Pulse width CS# low	1	-	-	t _{CYC}
t _{PWCSH}	Pulse width CS# high	1	-	-	t _{CYC}
t _{FDRD}	First Read Data Delay	5	-	-	t _{CYC}
t _{AS}	Address Setup Time	1	-	-	ns
t _{AH}	Address Hold Time	1	-	-	ns
t _{DSW}	Data Setup Time	4	-	-	ns
t _{DHW}	Data Hold Time	1	-	-	ns
t _{DSR}	Data Access Time	-	-	5	ns
t _{DHR}	Output Hold time	1	-	-	ns

8. Reliability of LCM

Reliability test condition:

Item	Condition	Time (hrs)	Assessment
High temp. Storage	80°C	48	No abnormalities in functions and appearance
High temp. Operating	70°C	48	
Low temp. Storage	-30°C	48	
Low temp. Operating	-20°C	48	
Humidity	40°C! 90%RH	48	
Temp. Cycle	-20°C — 25°C 70°C	10cycles	

Recovery time should be 24 hours minimum. Moreover, functions, performance and appearance ,etc. shall be free from remarkable deterioration within 50,000 hours under ordinary operating and storage conditions room temperature (20°C), normal humidity (20% RH), and in the area not exposed to direct sun light. The life time is not content the life time of the LED (for the life time of LED which decay only 50%,in the industry the experience value is 50000 hours, but there are notany experimentation data to support this).

9. Application Example

Figure : APPLICATION CIRCUIT FOR M7-BUS

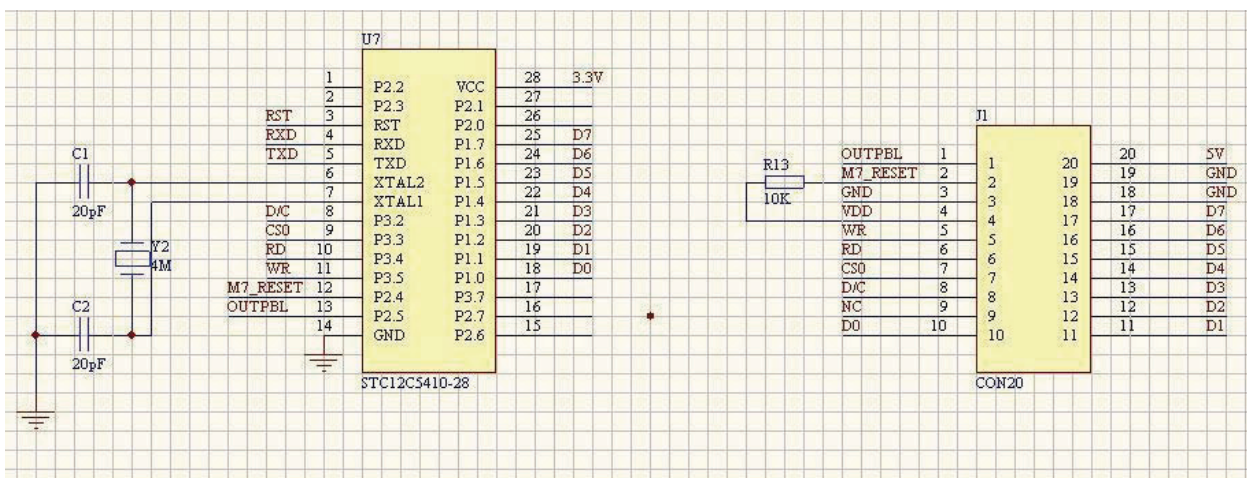

10. Program initialization Example

(1) M7_Bus.h File

```
/*
// Defines the data bus width
*****/
#define LCD_DATA_BUS_WIDTH 8 // Definition 8-bit data bus
#define LCD_DATA_BUS_WIDTH 16 // Definition 16-bit data bus
#define COLOR_MODULE 16 // Only support 16-bit bus
#define COLOR_MODULE 24 // support 16-bit bus
*****/
Define data port
*****/
#define DATA_PORTL P1
#define DATA_PORTH P2

#define LCD_SCREEN 500
/*
// Define the size of the LCD Resolution
*****/
#if LCD_SCREEN==320
#define LCD_320
#elif LCD_SCREEN==430
#define LCD_430
#elif LCD_SCREEN==500
#define LCD_500
#elif LCD_SCREEN==560
#define LCD_560
#elif LCD_SCREEN==700
#define LCD_700
#else
#define LCD_320
#endif
/*
above all of that is config for LCD Screen
*/
void ClearScreen(uint color);
*****/
M7_BUS IC /128PIN, Used to control read and write the way, if set 0, with 6800 bus MODE ,If set1,
for the 8080 bus mode. The following definition is 8080 mode

*****/

void M7_BUS_Instruction_Command_8(uchar cmd);
void M7_BUS_Instruction_Data_8(uchar sdata);
```

```

void M7_BUS_Data_Input(uint color);
void StartScroll(uint start);

void SetPixel(uint Col,uint Page,uint color); // Shows a phase factor point
uint GetPixel(uint Col,uint Page);// Get a pixel
void M7_BUSInit();

void GrayDisplay();
void ReadM7_BUSSet();
    // Io Config
    #define SetM7_BUSRD() SetBit(P3,4)
    #define ClrM7_BUSRD() ClrBit(P3,4)

    #define SetM7_BUSWR() SetBit(P3,5)
    #define ClrM7_BUSWR() ClrBit(P3,5)

    #define SetM7_BUSCS() SetBit(P3,3)
    #define ClrM7_BUSCS() ClrBit(P3,3)

    #define SetM7_BUSDC() SetBit(P3,2)
    #define ClrM7_BUSDC() ClrBit(P3,2)
    //HS,VS,PCLK and the dot clock pulse polarity    Setting
#ifdef LCD_350
    //LCD    Shift Clock Polarity - Set LCD shift clock active edge polarity, negative edge.
    #define CLKPOL                (1<<2)
    //6.4MHZ*1024*1024 = 100MHZ * PCLK_VALUE
    #define PCLK_VALUE                0x10624
    #define DISP_HOR_RESOLUTION        320L
    #define DISP_VER_RESOLUTION        240L

    #define DISP_HOR_PULSE_WIDTH        30
    #define DISP_HOR_BACK_PORCH        38
    #define DISP_HOR_FRONT_PORCH        8

    #define DISP_VER_PULSE_WIDTH        3
    #define DISP_VER_BACK_PORCH        15
    #define DISP_VER_FRONT_PORCH        4

    #define                                HT
(DISP_HOR_RESOLUTION+DISP_HOR_PULSE_WIDTH+DISP_HOR_BACK_PORCH+DISP_HOR_FRONT_PORCH)

```

```

#define HPS (DISP_HOR_PULSE_WIDTH+DISP_HOR_BACK_PORCH)
#define
(DISP_VER_PULSE_WIDTH+DISP_VER_BACK_PORCH+DISP_VER_FRONT_PORCH+DISP_VER_RESOLUTION)
#define VSP (DISP_VER_PULSE_WIDTH+DISP_VER_BACK_PORCH)
#endif
#ifdef LCD_430
//LCD Shift Clock Polarity - Set LCD shift clock active edge polarity, negative edge
#define CLKPOL (0<<2)
//9 MHz*1024*1024 = 100MHz * PCLK_VALUE
#define PCLK_VALUE 0x170a3
#define DISP_HOR_RESOLUTION 480
#define DISP_VER_RESOLUTION 272

#define DISP_HOR_PULSE_WIDTH 1
#define DISP_HOR_BACK_PORCH 43
#define DISP_HOR_FRONT_PORCH 8
#define DISP_VER_PULSE_WIDTH 4
#define DISP_VER_BACK_PORCH 10
#define DISP_VER_FRONT_PORCH 2

#define
(DISP_HOR_RESOLUTION+DISP_HOR_PULSE_WIDTH+DISP_HOR_BACK_PORCH+DISP_HOR_FRONT_PORCH)
#define HPS (DISP_HOR_PULSE_WIDTH+DISP_HOR_BACK_PORCH)
#define
(DISP_VER_PULSE_WIDTH+DISP_VER_BACK_PORCH+DISP_VER_FRONT_PORCH+DISP_VER_RESOLUTION)
#define VSP (DISP_VER_PULSE_WIDTH+DISP_VER_BACK_PORCH)

#endif

#ifdef LCD_500
//LCD Shift Clock Polarity - Set LCD shift clock active edge polarity, the effective increase
in the extension.
#define CLKPOL (1<<2)
//25MHz*1024*1024 = 100MHz * PCLK_VALUE
#define PCLK_VALUE 0x40fb5
#define DISP_HOR_RESOLUTION 640L
#define DISP_VER_RESOLUTION 480L

#define DISP_HOR_PULSE_WIDTH 10

```

```

#define DISP_HOR_BACK_PORCH          134
#define DISP_HOR_FRONT_PORCH        16

#define DISP_VER_PULSE_WIDTH         2
#define DISP_VER_BACK_PORCH         11
#define DISP_VER_FRONT_PORCH        32

#define                                HT
(DISP_HOR_RESOLUTION+DISP_HOR_PULSE_WIDTH+DISP_HOR_BACK_PORCH+DISP_HOR_FRONT_PORCH)
#define HPS (DISP_HOR_PULSE_WIDTH+DISP_HOR_BACK_PORCH)
#define                                VT
(DISP_VER_PULSE_WIDTH+DISP_VER_BACK_PORCH+DISP_VER_FRONT_PORCH+DISP_VER_RESOLUTION)
#define VSP (DISP_VER_PULSE_WIDTH+DISP_VER_BACK_PORCH)
#endif

#ifdef LCD_560 //5.6 panel display
//LCD Shift Clock Polarity - Set LCD shift clock active edge polarity, the effective increase in
the extension.
#define CLKPOL (1<<2)
//25MHZ*1024*1024 = 100MHZ * PCLK_VALUE
#define PCLK_VALUE 0x40fb5
#define DISP_HOR_RESOLUTION 640
#define DISP_VER_RESOLUTION 480

#define DISP_HOR_PULSE_WIDTH 10
#define DISP_HOR_BACK_PORCH 134
#define DISP_HOR_FRONT_PORCH 16
#define DISP_VER_PULSE_WIDTH 2
#define DISP_VER_BACK_PORCH 11
#define DISP_VER_FRONT_PORCH 32

#define                                HT
(DISP_HOR_RESOLUTION+DISP_HOR_PULSE_WIDTH+DISP_HOR_BACK_PORCH+DISP_HOR_FRONT_PORCH)
#define HPS (DISP_HOR_PULSE_WIDTH+DISP_HOR_BACK_PORCH)
#define                                VT
(DISP_VER_PULSE_WIDTH+DISP_VER_BACK_PORCH+DISP_VER_FRONT_PORCH+DISP_VER_RESOLUTION)
#define VSP (DISP_VER_PULSE_WIDTH+DISP_VER_BACK_PORCH)
#endif

```

```
#ifndef LCD_700 //7.0" PANEL
//LCD Shift Clock Polarity - Set LCD shift clock active edge polarity, the effective increase
in the extension.
```

```
#define CLKPOL (1<<2)
//pclk=26.2 mhz 30mHZ*1024*1024=100mhz * PCLK_VALUE
#define PCLK_VALUE 0x430E0
#define DISP_HOR_RESOLUTION 800
#define DISP_VER_RESOLUTION 480
```

```
#define DISP_HOR_PULSE_WIDTH 128
#define DISP_HOR_BACK_PORCH 88
#define DISP_HOR_FRONT_PORCH 40
```

```
#define DISP_VER_PULSE_WIDTH 3
#define DISP_VER_BACK_PORCH 25
#define DISP_VER_FRONT_PORCH 1
```

```
#define HT
(DISP_HOR_RESOLUTION+DISP_HOR_PULSE_WIDTH+DISP_HOR_BACK_PORCH+DISP_HOR_FRONT_PORCH)
#define HPS (DISP_HOR_PULSE_WIDTH+DISP_HOR_BACK_PORCH)
#define VT
(DISP_VER_PULSE_WIDTH+DISP_VER_BACK_PORCH+DISP_VER_FRONT_PORCH+DISP_VER_RESOLUTION)
#define VSP (DISP_VER_PULSE_WIDTH+DISP_VER_BACK_PORCH)
#endif
```

(2) M7_Bus.C File

```
#include "includes.h"
```

```
// NOTE: In the write command to the M7-B01, only with a low 8-bit data lines to transmit data.
```

```
// LCD initialization must be 8-bit bus transfers data and commands
```

```
void M7_BUS_Instruction_Command_8(uchar cmd)
```

```
{
```

```
ClrM7_BUSDC();
SetM7_BUSRD();
```

```
ClrM7_BUSCS();
ClrM7_BUSWR();
DATA_PORTL=cmd;
SetM7_BUSWR();
```

```

        SetM7_BUSCS();
    }
void M7_BUS_Instruction_Data_8(uchar sdata)
{
    SetM7_BUSDC();

    SetM7_BUSRD();

    ClrM7_BUSCS();
    ClrM7_BUSWR();
    DATA_PORTL=sdata;

    SetM7_BUSWR();
    SetM7_BUSCS();

}
void M7_BUS_Data_Input(uint color)
{
    static dataflag=0;
    //16-bit data bus 16-bit data bus 16-bit color
    #if LCD_DATA_BUS_WIDTH==16
        DATA_PORTL=(uchar)color;
        DATA_PORTH=(uchar)(color>>8);
        ClrM7_BUSWR();
        SetM7_BUSWR();

    #elif LCD_DATA_BUS_WIDTH==8
        DATA_PORTL=(uchar)((color>>8)&0x00f8);

        ClrM7_BUSWR();
        SetM7_BUSWR();

        DATA_PORTL=(uchar)((color>>3)&0x00fc);

        ClrM7_BUSWR();
        SetM7_BUSWR();

        DATA_PORTL=(uchar)((color<<3) & 0x00f8);

        ClrM7_BUSWR();
        SetM7_BUSWR();
    #endif
}
void M7_BUSInit()

```

{

```
M7_BUS_Instruction_Command_8(0x01); //Reset
Delay_Us(400);
Delay_Us(400);
```

```
M7_BUS_Instruction_Command_8(0x01);
Delay_Us(400);
Delay_Us(400);
```

```
//enable pll
M7_BUS_Instruction_Command_8(0xe0);
Delay_Us(400);
M7_BUS_Instruction_Data_8(0x01);
Delay_Us(400);
M7_BUS_Instruction_Command_8(0xe0);
Delay_Us(400);
M7_BUS_Instruction_Data_8(0x03);
Delay_Us(400);
```

```
//pll: n= 30 m= 3 100mhz
M7_BUS_Instruction_Command_8(0xe2);
M7_BUS_Instruction_Data_8(0x1D); //N= 30 =0X1D+1
M7_BUS_Instruction_Data_8(0x02); //M =3 =0X02+1
//Effectuate the multiplier and divider value
M7_BUS_Instruction_Data_8(0x04);
```

```
//dotclk setting
M7_BUS_Instruction_Command_8(0xe6);
M7_BUS_Instruction_Data_8(PCLK_VALUE>>16);
M7_BUS_Instruction_Data_8(PCLK_VALUE>>8);
M7_BUS_Instruction_Data_8(PCLK_VALUE); //
```

```
//panel setting
M7_BUS_Instruction_Command_8(0xB0);
// set 18-bit for 7" panel TY700TFT800480
M7_BUS_Instruction_Data_8(0x38|CLKPOL);//0x10
```

```
M7_BUS_Instruction_Data_8(0x00); // set TTL mode
// Set LCD panel size(DISP_HOR_RESOLUTION = 800) H
M7_BUS_Instruction_Data_8((DISP_HOR_RESOLUTION-1)>>8);
// Set LCD panel size(DISP_HOR_RESOLUTION = 800) L
M7_BUS_Instruction_Data_8(DISP_HOR_RESOLUTION-1);
// Set LCD panel size(DISP_VER_RESOLUTION = 480) H
```



```
M7_BUS_Instruction_Data_8((DISP_VER_RESOLUTION-1)>>8);
// Set LCD panel size(DISP_VER_RESOLUTION = 480) L
M7_BUS_Instruction_Data_8(DISP_VER_RESOLUTION-1);
M7_BUS_Instruction_Data_8(0x00);//0x00          // RGB sequence
```

```
//pixel format
M7_BUS_Instruction_Command_8(0x3a);
M7_BUS_Instruction_Data_8(0x50);
```

```
//hsync setting
M7_BUS_Instruction_Command_8(0xB4);
M7_BUS_Instruction_Data_8((HT-1)>>8);
M7_BUS_Instruction_Data_8(HT-1);
M7_BUS_Instruction_Data_8((HPS-1)>>8);
M7_BUS_Instruction_Data_8(HPS-1);
M7_BUS_Instruction_Data_8(DISP_HOR_PULSE_WIDTH-1);
M7_BUS_Instruction_Data_8(0x00);
M7_BUS_Instruction_Data_8(0x00);
M7_BUS_Instruction_Data_8(0x00);
```

```
//vsync setting
M7_BUS_Instruction_Command_8(0xB6);
M7_BUS_Instruction_Data_8((VT-1)>>8);
M7_BUS_Instruction_Data_8(VT-1);
M7_BUS_Instruction_Data_8((VSP-1)>>8);
M7_BUS_Instruction_Data_8(VSP-1);
M7_BUS_Instruction_Data_8(DISP_VER_PULSE_WIDTH-1);
M7_BUS_Instruction_Data_8(0x00);
M7_BUS_Instruction_Data_8(0x00);
```

```
//col start_end
M7_BUS_Instruction_Command_8(0x2a);
M7_BUS_Instruction_Data_8(0x00);
M7_BUS_Instruction_Data_8(0x00);
// Set LCD panel size(DISP_HOR_RESOLUTION = 800) H
M7_BUS_Instruction_Data_8((DISP_HOR_RESOLUTION-1)>>8);
// Set LCD panel size(DISP_HOR_RESOLUTION = 800) L
M7_BUS_Instruction_Data_8(DISP_HOR_RESOLUTION-1);
//row start_end
M7_BUS_Instruction_Command_8(0x2b);
M7_BUS_Instruction_Data_8(0x00);
M7_BUS_Instruction_Data_8(0x00);
// Set LCD panel size(DISP_VER_RESOLUTION = 480) H
M7_BUS_Instruction_Data_8((DISP_VER_RESOLUTION-1)>>8);
// Set LCD panel size(DISP_VER_RESOLUTION = 480) L
```

```

M7_BUS_Instruction_Data_8(DISP_VER_RESOLUTION-1);

M7_BUS_Instruction_Command_8(0x36);
M7_BUS_Instruction_Data_8(0x00);

// SET M7-BUS IC 8bit Set pixel data interface
M7_BUS_Instruction_Command_8(0xf0);

//16-bit data bus as RGB 565 16-bit data transfer
#if LCD_DATA_BUS_WIDTH==16
    M7_BUS_Instruction_Data_8(0x03); //03 00 8 bit i 03 16bit

#endif
#if LCD_DATA_BUS_WIDTH==8 //8bit bus

    M7_BUS_Instruction_Data_8(0x00); //03 00 8bit 03 16bit

#endif
//display on
M7_BUS_Instruction_Command_8(0x29);
}
void StartScroll(uint start)
{
    M7_BUS_Instruction_Command_8(0x37);
    M7_BUS_Instruction_Data_8(start>>8);
    M7_BUS_Instruction_Data_8(start);
}
void ClearScreen(uint color)
{
    long i ,j;
    /*****
    Set the size of the display screen
    *****/
    M7_BUS_Instruction_Command_8(0x2a);
    M7_BUS_Instruction_Data_8(0x00);
    M7_BUS_Instruction_Data_8(0x00);
    M7_BUS_Instruction_Data_8(((DISP_HOR_RESOLUTION-1)>>8)&0xff);
    M7_BUS_Instruction_Data_8((DISP_HOR_RESOLUTION-1)&0xff);//320
    //row start_end
    M7_BUS_Instruction_Command_8(0x2b);
    M7_BUS_Instruction_Data_8(0x00);
    M7_BUS_Instruction_Data_8(0x00);
    M7_BUS_Instruction_Data_8(((DISP_VER_RESOLUTION-1)>>8)&0xff);
    M7_BUS_Instruction_Data_8((DISP_VER_RESOLUTION-1)&0xff);
    M7_BUS_Instruction_Command_8(0x2c);

```

```

SetM7_BUSDC();
SetM7_BUSRD();
ClrM7_BUSCS();
for (i=0;i<DISP_HOR_RESOLUTION;i++)
{
    for (j=0;j<DISP_VER_RESOLUTION;j++)
    {
        M7_BUS_Data_Input(color);

    }
}
SetM7_BUSCS();
}
// Shows part of the picture
void ClearPartColor(uint color,uint startx,uint starty,uint endx,uint endy)
{
    uint i,j;
    M7_BUS_Instruction_Command_8(0x2a);
    M7_BUS_Instruction_Data_8(startx/256);
    M7_BUS_Instruction_Data_8(startx%256);

    M7_BUS_Instruction_Data_8((endx-1)/256);
    M7_BUS_Instruction_Data_8((endx-1)%256);//480

    M7_BUS_Instruction_Command_8(0x2b);
    M7_BUS_Instruction_Data_8(starty/256);
    M7_BUS_Instruction_Data_8(starty%256);

    M7_BUS_Instruction_Data_8((endy-1)/256);
    M7_BUS_Instruction_Data_8((endy-1)%256);//272

    M7_BUS_Instruction_Command_8(0x2c);

    SetM7_BUSDC();
    SetM7_BUSRD();
    ClrM7_BUSCS();

    for(i=starty;i<endy;i++)
    {
        for(j=startx;j<endx;j++)
        {
            M7_BUS_Data_Input(color);
        }
    }
}

```

```

    }
    SetM7_BUSCS();

}
uint returncolor(uchar R,uchar G,uchar B)
{
    uint R5,G6,B5 ;
R= R&0xf8; //565rgb
    G= G&0xfc; //565rgb
    B= B&0xf8; //565rgb

    R5= R>>3;
    G6= G>>2;
    B5= B>>3;
    return (R5<<11)|(G6<<5)| B5;
}
void GrayDisplay() // Gradation display
{
    uint x,color;
    uchar r,g,b,i;
    x=0;
    r=0;
    g=0;
    b=0;
    for(i=0;i<8;i++)
    {

        color=returncolor(r,g,b);
        ClearPartColor(color,x,0,x+55,136);
        x+=55;
        ClearPartColor(0x0000,x,0,x+5,136);
        x+=5;
        if(r==0)
        {
            r=0x1f;
            g=0x1f;
            b=0x1f;
        }
        else
        {
            r=r+0x10;
            g=g+0x10;
            b=b+0x10;
        }
    }
    x=0;
}

```



```
for(i=0;i<8;i++)
{
    color=returncolor(r,g,b);
    ClearPartColor(color,x,136,x+55,272);
    x+=55;
    ClearPartColor(0x0000,x,136,x+5,272);
    x+=5;

    r=r+0x10;
    g=g+0x10;
    b=b+0x10;
}
}
```

The logo for MIDAS, featuring the word "MIDAS" in a bold, yellow, serif font. The text is centered within a light blue, horizontally-oriented oval shape that has a subtle, wavy texture.

11.Packing Information

TBD

The logo for MIDAS, featuring the word "MIDAS" in a bold, yellow, sans-serif font. The text is centered within a light blue, horizontally-oriented oval shape that has a subtle, wavy texture.