



Address: Midas Components Limited, Electra House, 32 Southdown Road, Great Yarmouth, Norfolk, NR31 0DU  
Telephone: +44 (0)1493 602602  
Fax: +44 (0)1493 665111  
Email: [sales@midascomponents.co.uk](mailto:sales@midascomponents.co.uk)  
Website: [www.midascomponents.co.uk](http://www.midascomponents.co.uk)

# Specification

## MC122032B6W-SPR

A large, faded version of the MIDAS logo is centered on the page. It consists of the word "MIDAS" in a yellow, sans-serif font, set within a light blue oval background with a wavy texture.

## BOOKBINDING AREA

DOC.

DATASHEET STATEMENT

1. The following icons are absolutely designed by Midas independently in 2007-SEP. They are not in common use in the LCD industry yet but just used for marking out Midas products' characteristics quickly and simply without any special meaning. Midas reserves the composing right and copyright. No one else is allowed to adopt these icons without Midas approval.
2. The ISO9001 logo used in this document is authorized by SGS ([www.sgs.com](http://www.sgs.com)). Midas had already successfully passed the strict and professional ISO9001:2000 Quality Management System Certification and got the certificate (No.: CN07/00404)
3. The technologies/techniques/crafts which denoted by the following icons are not exclusively owned by Midas, but also shared by Midas LCD strategic cooperators, however all these technologies/techniques/crafts have been finally confirmed by Midas professional engineers and QC department.
4. As the difference in test standard and test conditions, also Midas insufficient familiarity with the actual LCD using environment, all the referred information in this DATASHEET (including the icons) only have two functions:  
4.1: providing quick reference when you are judging whether or not the product meets your requirements.  
4.2: listing out definitely the tolerance.

SAMPLE APPROVAL document rather than consider this DATASHEET as the standard for judging whether or not the LCD meets your requirements. Once you instruct Midas to a mass-production without definite demand for providing sample before, Midas will disclaim all responsibility if the mass-production is proved not meeting with your requirements.

5. The sequence of the icons is random and doesn't indicate the importance grade.
6. Icons explanation

Midas 2006 version logo. Midas is an integrated manufacturer of flat panel display (FPD). Midas supplies TN, HTN, STN, FSTN monochrome LCD panel; COB, COG, TAB LCD module; and all kinds of LED backlight.



### FAST RESPONSE TIME

This icon on the cover indicates the product is with high response speed; Otherwise not.



### PROTECTION CIRCUIT

This icon on the cover indicates the product is with protection circuit; Otherwise not.



### HIGH CONTRAST

This icon on the cover indicates the product is with high contrast; Otherwise not.



### LONG LIFE VERSION

This icon on the cover indicates the product is long life version (over 9K hours guaranteed); Otherwise not.



### WIDE VIEWING SCOPE

This icon on the cover indicates the product is with wide viewing scope; Otherwise not.



### Anti UV VERSION

This icon on the cover indicates the product is against UV line. Otherwise not.



### RoHS COMPLIANCE

This icon on the cover indicates the product meets ROHS requirements; Otherwise not.



### OPERATION TEMPERATURE RANGE

This icon on the cover indicates the operating temperature range (X-Y).



### 3TIMES 100% QC EXAMINATION

This icon on the cover indicates the product has passed Midas thrice 100% QC. Otherwise not.



### TWICE SELECTION OF LED MATERIALS

This icon on the cover indicates the LED had passed Midas twice strict selection which promises the product's identical color and brightness; Otherwise not.



### Vcm = 3.0V

This icon on the cover indicates the product can work at 3.0V exactly; otherwise not.



### N SERIES TECHNOLOGY (2008 developed)

New structure, new craft, new technology and new materials inside both LCD module and LCD panel to improve the "RainBow"

BOOKBINDING AREA

STANDARD  
DOC.

REVISION RECORD

PAGE

1/18

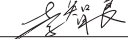
NO.	DATE	DESCRIPTION	ITEM	PAGE	APPROVED
1	2011.05	INITIAL ISSUED	ALL	ALL	

MIDAS

## Midas LCD Part Number System

**MC COG 132033 A \* 6 W \* \* - S N T L W \* \***  
 1 2 3 4 5 6 7 8 9 - 10 11 12 13 14 15 16

- 1 = **MC:** Midas Components
- 2 = **Blank:** COB (chip on board) **COG:** chip on glass
- 3 = **No of dots** (e.g. 240064 = 240 x 64 dots) (e.g. 21605 = 2 x 16 5mm C.H.)
- 4 = **Series**
- 5 = **Series Variant:** A to Z – **see addendum**
- 6 = **3:** 3 o'clock **6:** 6 o'clock **9:** 9 o'clock **12:** 12 o'clock
- 7 = **S:** Normal (0 to + 50 deg C) **W:** Wide temp. (-20 to + 70 deg C) **X:** Extended temp (-30 + 80 Deg C)
- 8 = **Character Set**  
**Blank:** Standard (English/Japanese)  
**C:** Chinese Simplified (Graphic Displays only)  
**CB:** Chinese Big 5 (Graphic Displays only)  
**H:** Hebrew  
**K:** European (std) (English/German/French/Greek)  
**L:** English/Japanese (special)  
**M:** European (English/Scandinavian)  
**R:** Cyrillic  
**W:** European (English/Greek)  
**U:** European (English/Scandinavian/Icelandic)
- 9 = **Bezel Height** (where applicable / available)

	Top of Bezel to Top of PCB	Common (via pins 1 and 2)	Array or Edge Lit
<b>Blank</b>	9.5mm / not applicable	Common	Array
<b>2</b>	8.9 mm	Common	Array
<b>3</b>	7.8 mm	Separate	Array
<b>4</b>	7.8 mm	Common	Array
<b>5</b>	9.5 mm	Separate	Array
<b>6</b>	7 mm	Common	Array
<b>7</b>	7 mm	Separate	Array
<b>8</b>	6.4 mm	Common	Edge
<b>9</b>	6.4 mm	Separate	Edge
<b>A</b>	5.5 mm	Common	Edge
<b>B</b>	5.5 mm	Separate	Edge
<b>D</b>	6.0mm	Separate	Edge
<b>E</b>	5.0mm	Separate	Edge
<b>F</b>	4.7mm	Common	Edge
<b>G</b>	3.7mm	Separate	EL

- 10 = **T:** TN **S:** STN **B:** STN Blue **G:** STN Grey **F:** FSTN **F2:** FFSTN
- 11 = **P:** Positive **N:** Negative
- 12 = **R:** Reflective **M:** Transmissive **T:** Transflective
- 13 = **Backlight:** **Blank:** Reflective **L:** LED
- 14 = **Backlight Colour:** **Y:** Yellow-Green **W:** White **B:** Blue **R:** Red **A:** Amber **O:** Orange **G:** Green **RGB:** R.G.B.
- 15 = **Driver Chip:** **Blank:** Standard **I:** I<sup>2</sup>C **T:** Toshiba T6963C **A:** Avant SAP1024B **R:** Raio RA8835
- 16 = **Voltage Variant:** e.g. **3** = 3v

**BOOKBINDING AREA**

	<b>STANDARD DOC.</b>	<b>CONTENTS</b>	<b>PAGE</b>	<b>3/20</b>
--	--------------------------	-----------------	-------------	-------------

1.	GENERAL SPECIFICATIONS -----	Page 4
2.	MECHANICAL SPECIFICATIONS -----	Page 4
3.	ABSOLUTE MAXIMUM RATINGS -----	Page 4
4.	ELECTRONICAL CHARACTERISTIC -----	Page 4
5.	OPTICAL CHARACTERISTICS -----	Page 5
6.	AC CHARACTERISTICS -----	Page 6
7.	EXTERNAL DIMENSION-----	Page 7
8.	PIN ASSIGNMENT -----	Page 8
9.	BLOCK DIAGRAM AND POWER SUPPLY -----	Page 8
10.	RELATION BETWEEN DISPLAY PATTERN AND DRIVERS -----	Page 9
11.	INSTRUCTION CODE -----	Page 10
12.	INSTRUCTION DESCRIPTION -----	Page 11
13.	APPLICATION EXAMPLE -----	Page 18
14.	PACKING DETAIL -----	Page 20

**BOOKBINDING AREA**

	<b>PRODUCT SPEC.</b>	<b>MODE NO.</b>	<b>PAGE</b>	<b>4/20</b>
		<b>MC122032B6W-SPR</b>		

**1. GENERAL SPECIFICATIONS**

<b>ITEM</b>	<b>NOMINAL DIMENSIONS / AVAILABLE OPTIONS</b>
DISPLAY FORMAT	122 X 32 DOT MATRIX
LCD PANEL OPTIONS	STN (Yellow-green color)
POLARIZER OPTIONS	Positive, Reflective
BACKLIGHT OPTIONS	No backlight
VIEWING ANGLE OPTIONS	6:00 ( Bottom )
TEMPERATURE RANGE OPTIONS	Wide temperature range ( -20°C ~ 70°C )
CONTROLLER IC	AVANT
DISPLAY DUTY	1/32
DRIVING BIAS	1/7

**2. MECHANICAL SPECIFICATIONS**

<b>OVERALL SIZE</b>	LED backlight version : 84.0 x 44.0 x max 10.0				mm
<b>VIEWING AREA</b>	64.0W x 17.9H	mm	<b>HOLE-HOLE</b>	76.0W x 36.0H	mm
<b>DOT SIZE</b>	0.40W x 0.45H	mm	<b>DOT PITCH</b>	0.04W x 0.04H	mm
<b>WEIGHT (EL BKL)</b>	86.0	g	<b>WEIGHT (LED BKL)</b>	105.0	g

**3. ABSOLUTE MAXIMUM RATINGS**

<b>ITEM</b>	<b>SYMBOL</b>	<b>CONDITION</b>	<b>MIN</b>	<b>MAX</b>	<b>UNIT</b>
POWER SUPPLY ( LOGIC)	Vdd	25°C	-0.3	7.0	V
POWER SUPPLY (LCD)	V0	25°C	Vdd -13.5	Vdd +0.3	V
INPUT VOLTAGE	Vin	25°C	-0.3	Vdd +0.3	V
OPERATING TEMPERATURE	Vopr	—	-20	70	°C
STORAGE TEMPERATURE	Vstg	—	-30	80	°C

**4. ELECTRONICAL CHARACTERISTIC\***

<b>ITEM</b>	<b>SYMBOL</b>	<b>CONDITION</b>	<b>STANDARD</b>			<b>UNIT</b>
			<b>MIN</b>	<b>TYP</b>	<b>MAX</b>	
Input voltage	Vdd	+5V	4.7	5.0	5.5	V
Supply current	Idd	Vdd=5V	—	1.5	—	mA
Recommended LCD driving voltage for normal temp. Version module	Vdd - V0	-20°C	4.25	—	4.70	V
		0°C	4.20	—	4.55	
		25°C	4.20	4.40	4.50	
		50°C	4.10	—	4.45	
		70°C	3.90	—	4.40	

\* The above data are for reference only.

	PRODUCT SPEC.	MODE NO.	PAGE	5/20
		MC122032B6W-SPR		

**5. OPTICAL CHARACTERISTICS**

FOR TN TYPE LCD MODULE (TA=25 °C, Vdd=5.0V ± 0.25V)						
ITEM	SYMBOL	CONDITION	MIN	TYP	MAX	UNIT
VIEWING ANGLE	$\Phi 2 - \Phi 1$	K=4	30	---	---	deg
	$\theta$		25			
CONTRAST RATIO	K	---	---	2	---	---
RESPONSE TIME(RISE)	TR	---	---	120	150	ms
RESPONSE TIME(FALL)	TF	---	---	120	150	ms

FOR STN TYPE LCD MODULE (TA=25 °C, Vdd=5.0V ± 0.25V)						
ITEM	SYMBOL	CONDITION	MIN	TYP	MAX	UNIT
VIEWING ANGLE	$\Phi 2 - \Phi 1$	K=4	40	---	---	deg
	$\theta$		60			
CONTRAST RATIO	K	---	---	6	---	---
RESPONSE TIME(RISE)	TR	---	---	150	250	ms
RESPONSE TIME(FALL)	TF	---	---	150	250	ms

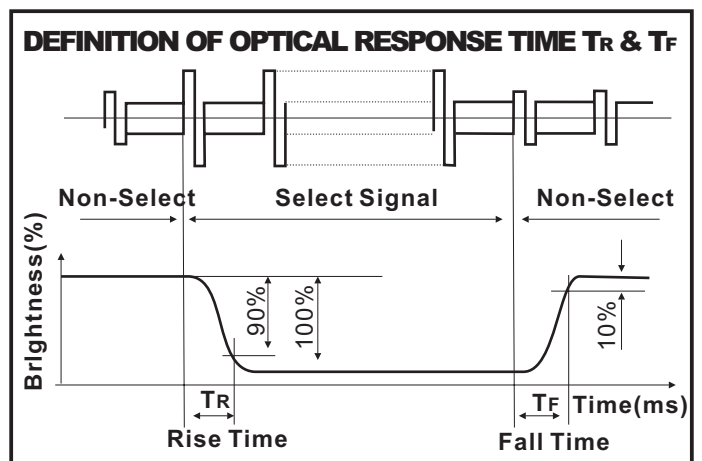
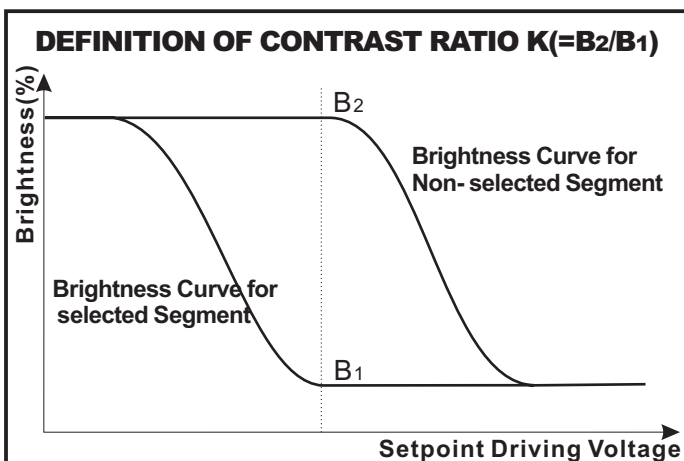
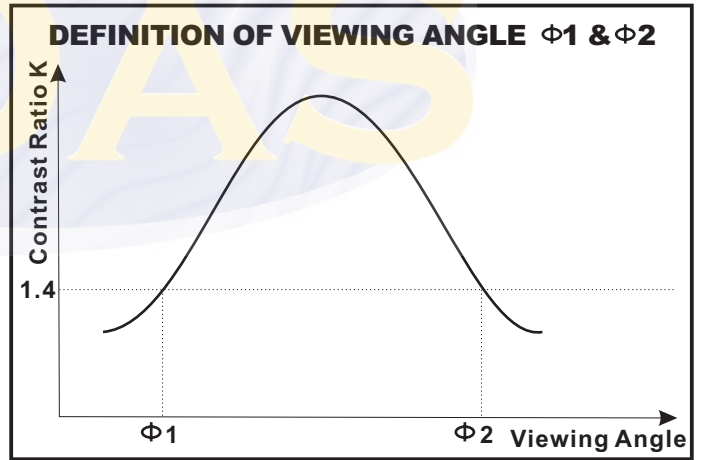
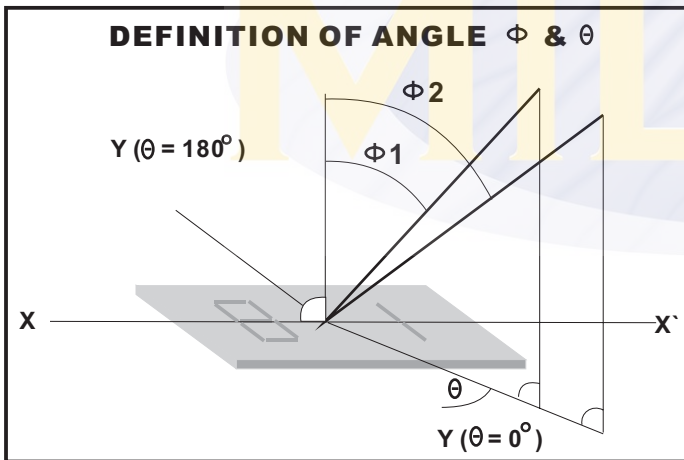

	PRODUCT SPEC.	MODE NO.	PAGE	6/20
		MC122032B6W-SPR		

6. AC CHARACTERISTIC

$V_{dd}=5.0V \pm 10\%, V_{SS}=0V, T_a = -20 \sim +75^\circ C$

Parameter	Symbol	Min	Max	Condition	Unit
Address set up time	$t_{AW6}$	20	—	—	ns
Address hold time	$t_{AH6}$	10	—		ns
System cycle time	$t_{CYC6}$	1000	—		ns
E pulse width	Read	100	—		ns
	Write	80	—		ns
Data set up time	$t_{DS6}$	80	—		ns
Data hold time	$t_{DH6}$	10	—	ns	
Access time	$t_{ACC6}$	—	90	$C_L=100pF$	ns
Output disable time	$t_{OH6}$	10	60		ns

\*Input signal rise time and fall time are less than 15ns.

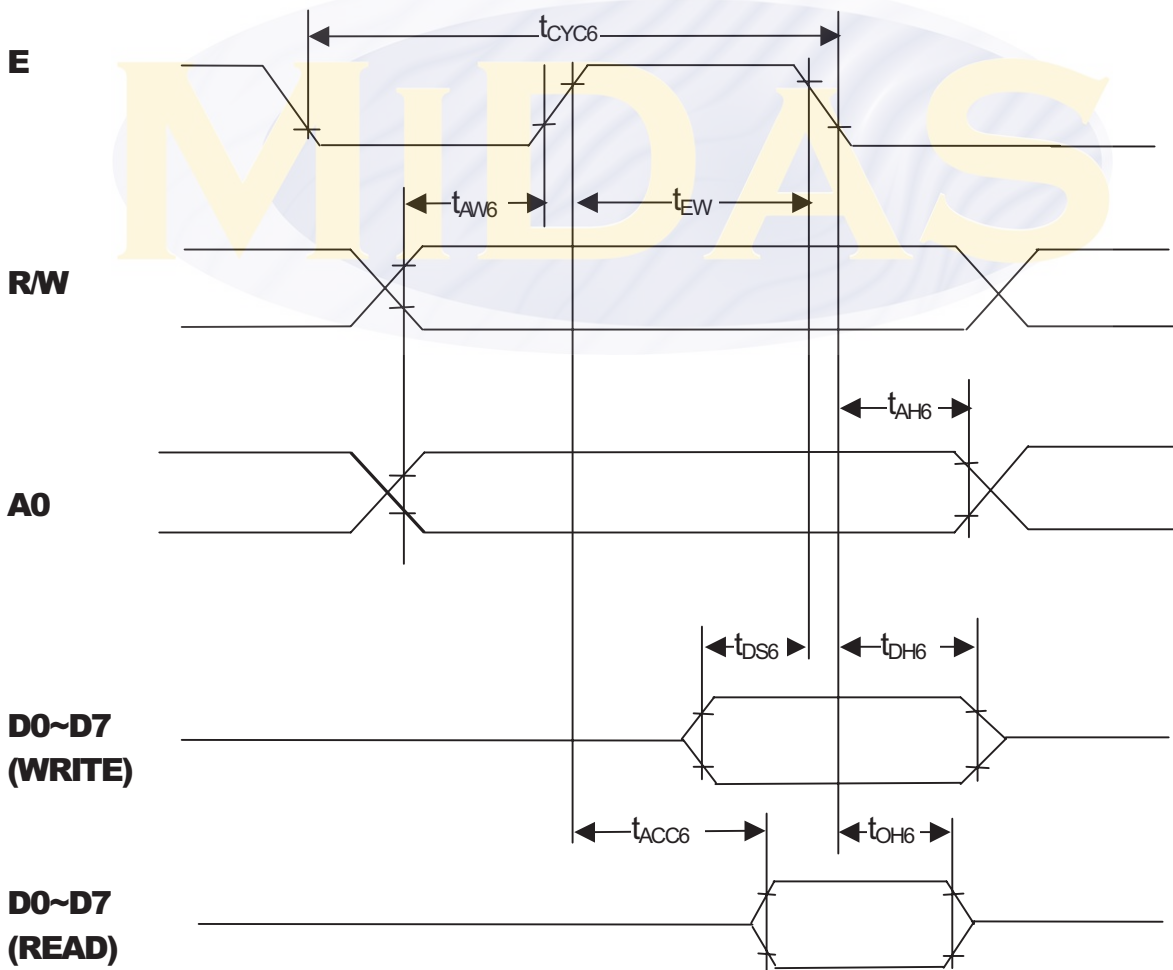



7.EXTERNAL DIMENSIONS

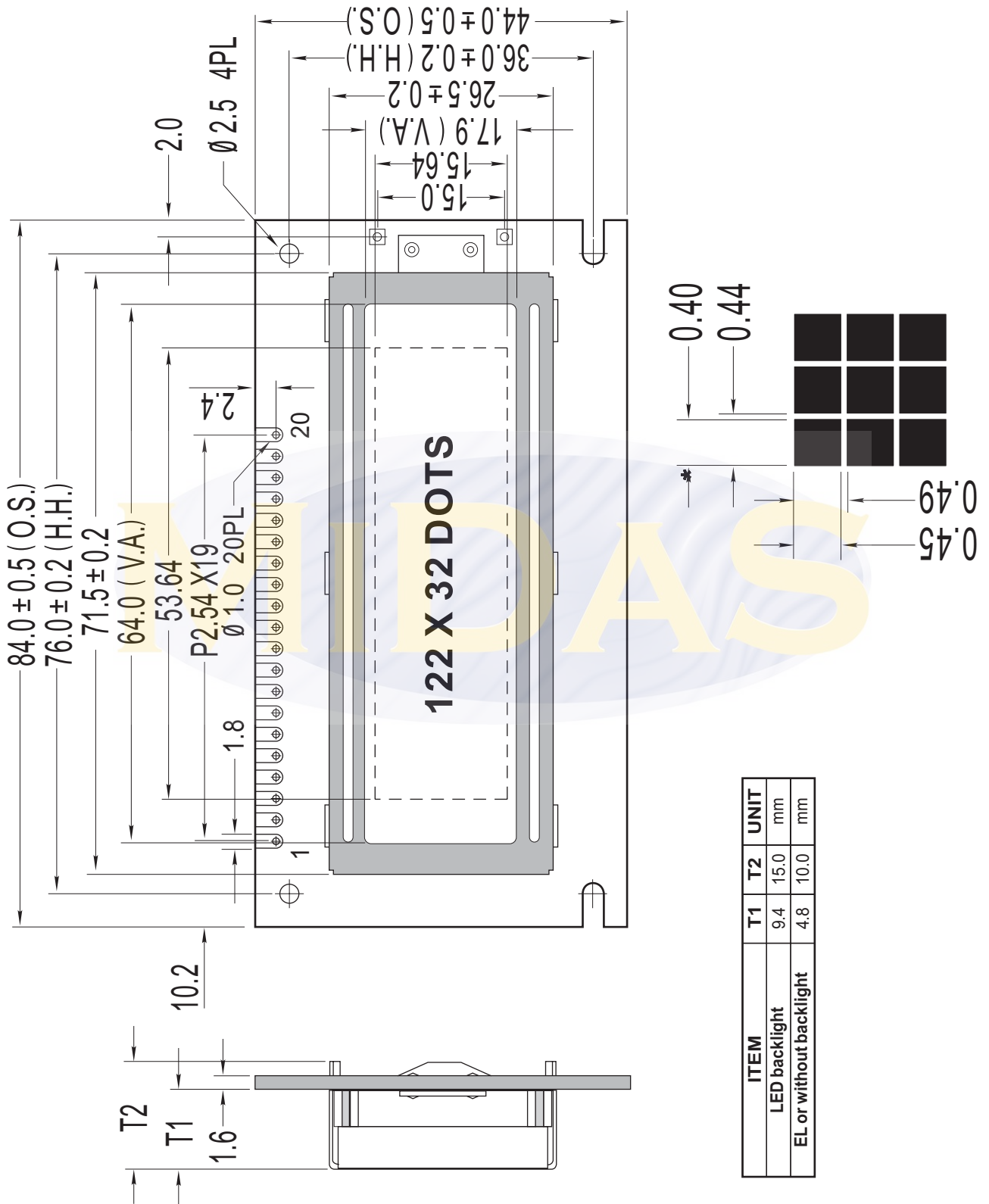

	<b>PRODUCT SPEC.</b>	<b>MODE NO.</b>	<b>PAGE</b>	<b>8/20</b>
		MC122032B6W-SPR		

**8. PIN ASSIGNMENT**

PIN NO.	SYMBOL	FUNCTION	REMARK
1	Vss	Power Supply	0V
2	Vdd		+5V
3	V0		Contrast Adjust
4	A0	H/L H: Data; L: Instruction code	
5	CS1	Chip 1 Enable signal	
6	CS2	Chip 2 Enable signal	
7	CL	Clock Input (2K Hz)	
8	E	Enable Signal	
9	R/W	Read / Write	
10	DB0	Data Bit 0	
11	DB1	Data Bit 1	
12	DB2	Data Bit 2	
13	DB3	Data Bit 3	
14	DB4	Data Bit 4	
15	DB5	Data Bit 5	
16	DB6	Data Bit 6	
17	DB7	Data Bit 7	
18	RST	Reset Signal	
19	NC	No Connection	
20	NC	No Connection	

**9.1 . BLOCK DIAGRAM**

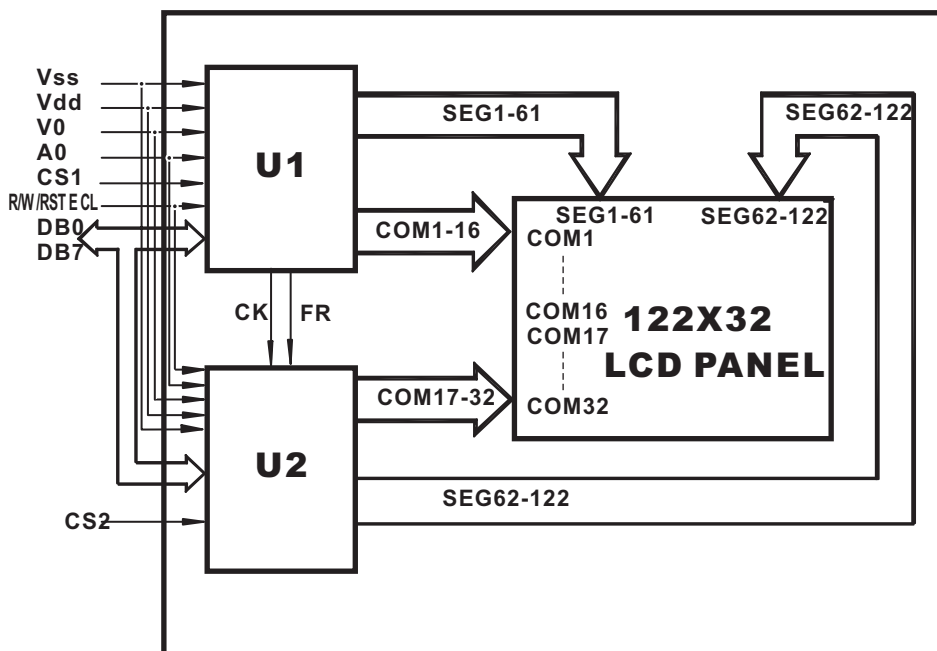

**9.2 . POWER SUPPLY**

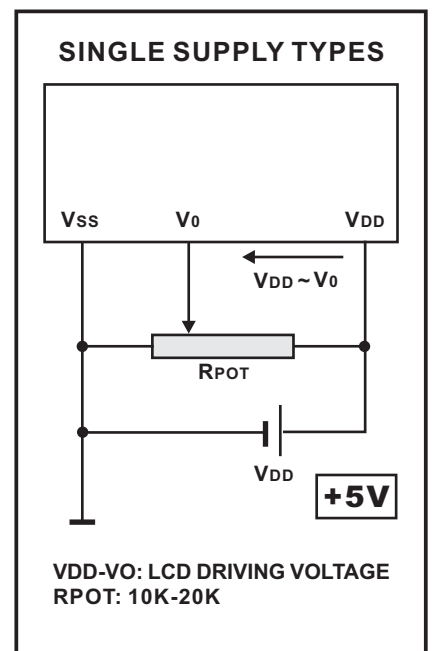

	<b>PRODUCT SPEC.</b>	<b>MODE NO.</b>	<b>PAGE</b>	<b>9/20</b>
		<b>MC122032B6W-SPR</b>		

**10. RELATION BETWEEN DISPLAY PATTERN AND DRIVERS**

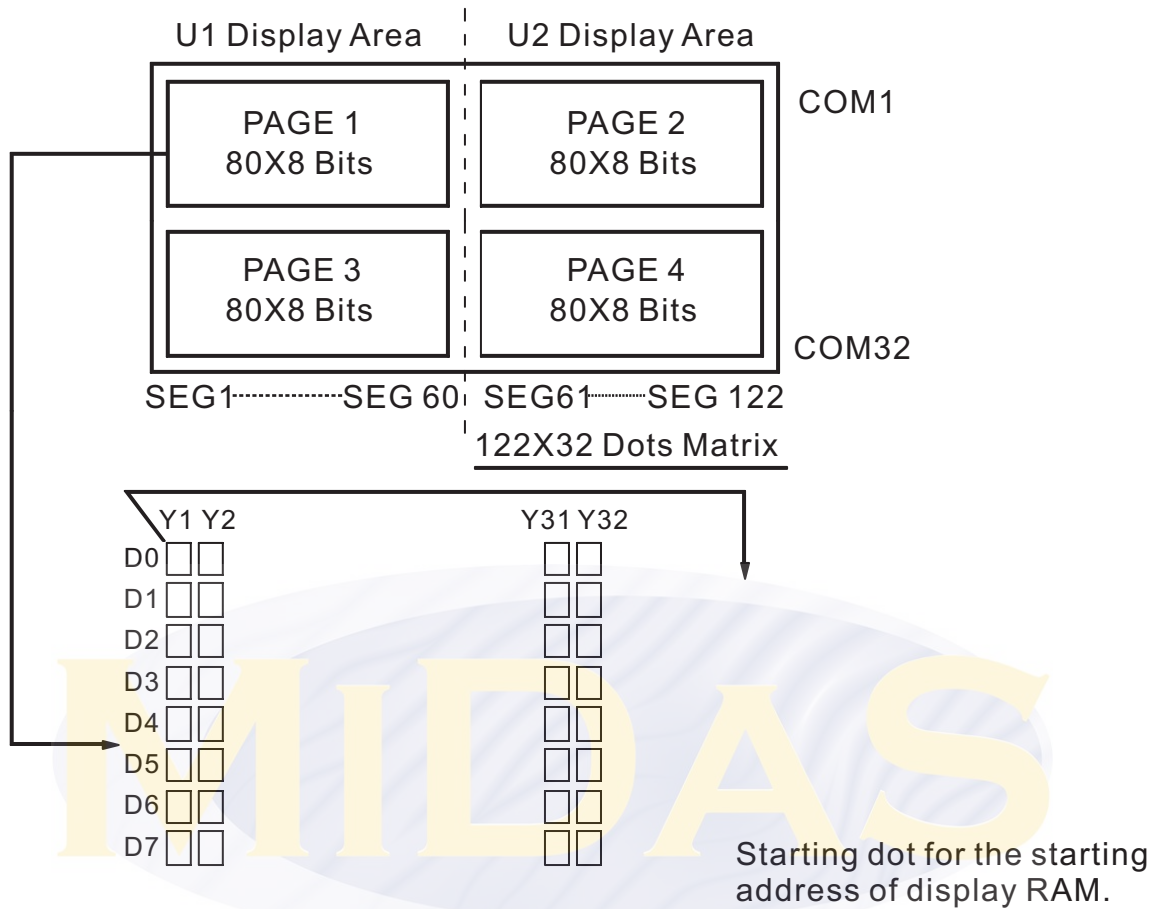

Each segment driver has 4 pages RAM, and each page has 80x8 bits RAM. D0~D7 are 8 bits transmitted data, where D0 is LSB and D7 is MSB.

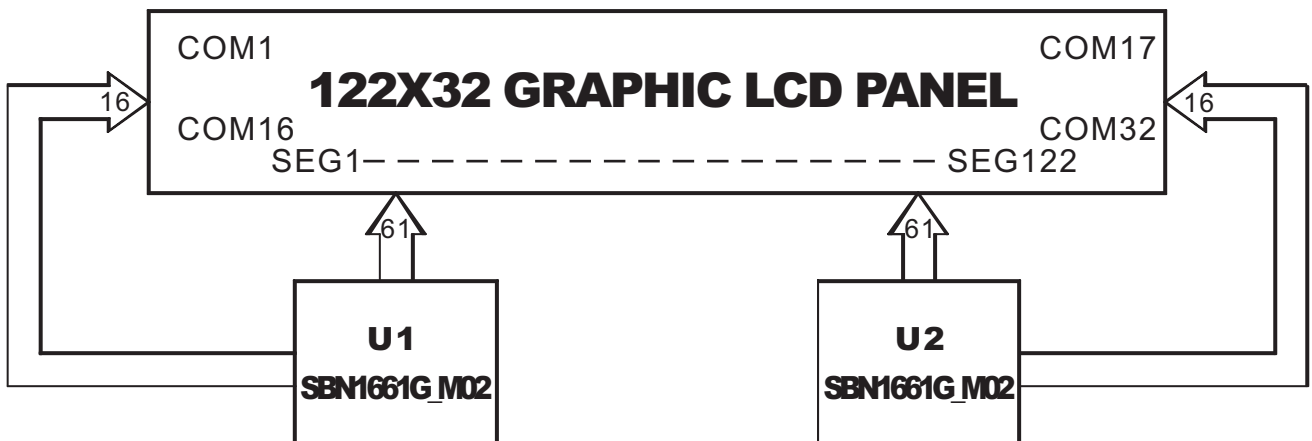

	<b>PRODUCT SPEC.</b>	<b>MODE NO.</b>		<b>PAGE 10/20</b>
		<b>MC122032B6W-SPR</b>		

**11. INSTRUCTIONCODE**

Instruction	A0	R/W	D7	D6	D5	D4	D3	D2	D1	D0	Description
Display on/off	0	0	1	0	1	0	1	1	1	0/1	Whole disp on/off 1: on 0: off
Display Start line	0	0	1	1	0	DISPLAY START ADDRESS (1-31)				Determine the disp line correspond to the COM0	
Page address set	0	0	1	0	1	1	1	0	Page (0-3)		Set the page of disp data RAM
Column address set	0	0	0	Column address(0-79)						Set the column address of disp data RAM	
Status read	0	1	B U S Y	A D C	O N / O F F	R E S E T	0	0	0	0	BUSY 0: ready 1: working ADC 0: counter clockwise 1; clockwise output ON/OFF 0: disp on 1: disp off RESET 0; normal 1: reset
Write display data	1	0	Write data							Write data to disp RAM	Access the predetermined address of the disp RAM
Read display data	1	1	Read data							Read data from disp RAM	
ADC select	0	0	1	0	1	0	0	0	0	0/1	Determine the mode reading of the disp RAM 0: clockwise output 1: counter clockwise output
Static drive on/off	0	0	1	0	1	0	0	1	0	0/1	Select the dynamic or static driving 1: static driving 0: dynamic driving
Duty ratio select	0	0	1	0	1	0	1	0	0	0/1	Select the duty ratio 0: 1/16 1: 1/32
Read Modify write	0	0	1	1	1	0	0	0	0	0	Increment the column address register when writing but no change when reading
END	0	0	1	1	1	0	1	1	1	0	Release from the Read Modify Write mode
Reset	0	0	1	1	1	0	0	0	1	0	Set the display start line register to 1st line, page add register to 3.
Power save (dual command)	0 0	0 0	1 1	0 0	1 1	0 0	1 0	1 1	1 0	0 1	Set the power save mode by selecting disp off and static driving on.



	<b>PRODUCT SPEC.</b>	<b>MODE NO.</b>	<b>PAGE 12/20</b>
		<b>MC122032B6W-SPR</b>	

### C. Page Address Set

When MPU access the display Data RAM, the page address corresponded to the row address must be selected.

The access in the display Data RAM is available by setting the page and column address. The display is no change when the page address is changed.

	A0	R/W	D7	D6	D5	D4	D3	D2	D1	D0
Code	0	0	1	0	1	1	1	0	A1	A0

A1	A0	Page
0	0	0
0	1	1
1	0	2
1	1	3

### D. Column Address Set

This instruction set the column address in the Display Data RAM. When the MPU access the Display Data RAM continuously, the column address increase 1 automatically, therefore, the MPU can access the data only without address setting. The increment of the column address is stopped by the address of 50H automatically, but the page address is no change even if the column address increase to 50H and stop.

	A0	R/W	D7	D6	D5	D4	D3	D2	D1	D0
Code	0	0	0	A6	A5	A4	A3	A2	A1	A0

A6	A5	A4	A3	A2	A1	A0	ColumnAdd.
0	0	0	0	0	0	0	0
0	0	0	0	0	0	1	1
1	0	0	1	1	1	0	4E
1	0	0	1	1	1	1	4F

	<b>PRODUCT SPEC.</b>	<b>MODE NO.</b> MC122032B6W-SPR	<b>PAGE</b>	<b>13/20</b>
--	----------------------	------------------------------------	-------------	--------------

### E. Status Read

This instruction read out the internal status.

	A0	R/W	D7	D6	D5	D4	D3	D2	D1	D0
Code	0	1	BUSY	ADC	ON/OFF	RESET	0	0	0	0

**BUSY:** BUSY=1 indicate the operating or the Reset cycle  
The instruction can be input after the BUSY status change to 0.

**ADC:** Indicate the output correspondence of column ( segment ) address and segment driver.  
 0: Counter clockwise Output (Inverse)  
     Column Address 79 - n      ←————→ Segment Driver n  
 1: Clockwise Output           (Normal)  
     Column Address n         ←————→ Segment Driver n

**ON/OFF:** Indicate the whole display On / Off status.

- 0 : Whole Display On
- 1 : Whole Display Off

**(Note)** The data 0 = On and 1 = Off of Display On/ Off status read out is inverted with the Display On/Off instruction data of 1 = On and 0 = Off

**RESET:** Indicate the initialization period by reset instruction.

- 0:         ———
- 1: Initialization Period

### F. Write Display Data

This instruction write the 8-bit data on the data bus into the Display RAM.  
The column ( segment ) address increase 1 automatically when writing, therefore, the MPU can write the 8-bit data into the Display Data RAM without address setting.

	A0	R/W	D7	D6	D5	D4	D3	D2	D1	D0
<b>61SEG</b>	1	0	WriteData							

	<b>PRODUCT SPEC.</b>	<b>MODE NO.</b>	<b>PAGE</b>	<b>14/20</b>
		<b>MC122032B6W-SPR</b>		

### G. Read Display Data

This instruction read out the 8-bit data from Display Data RAM which addressed by the column and page address. In case of the Read Modify Write Mode is Off, the column address increase 1 automatically after each read out, therefore, the MPU can read out the 8-bit data from the Display Data RAM continuously without address setting.

	A0	R/W	D7	D6	D5	D4	D3	D2	D1	D0
Code	1	1	Read Data							

### H. ADC Select

This instruction set the correspondence of column address in the Display Data RAM and segment driver out. Therefore, the order fo segment output can be changed by the software, and no restriction of the LSI placement against the LCD panel.

	A0	R/W	D7	D6	D5	D4	D3	D2	D1	D0
Code	0	0	1	0	1	0	0	0	0	D

D 0 : Clockwise Output (Inverse)  
 1 : Counter Clockwise Output (Normal)

### I. Static Drive On/ Off

This instruction executes the all common output terms on and whole display on obligatory

	A0	R/W	D7	D6	D5	D4	D3	D2	D1	D0
Code	0	0	1	0	1	0	0	1	0	D

D 0 : Static Drive Off (Normal Operation)  
 1 : Static Drive On (Whole Display Turns On)

When the Display Off mode is selected ( Display Off ) in Static Driver On status, the internal circuits put on the power save mode.



	<b>PRODUCT SPEC.</b>	<b>MODE NO.</b> MC122032B6W-SPR	<b>PAGE</b>	<b>15/20</b>
--	----------------------	------------------------------------	-------------	--------------

### J. Duty ratio Select

This instruction set the LCD driving duty ratio.

	A0	R/W	D7	D6	D5	D4	D3	D2	D1	D0
Code	0	0	1	0	1	0	1	0	0	D

D    0 : 1/16 Duty  
      1 : 1/32 Duty

### K. Read Modify Write

After this instruction is executed, the column address increase 1 automatically when Display Data Write Instruction execution, but the address is not changed when the Display Data Read Instruction execution.

This status continues during End instruction execution. When the End instruction is entered the column address back to the address where Read Modify Write instruction entering. By this function, the load of MPU for example cyclic data writing operation like as cursor blink etc., can be reduced.

	A0	R/W	D7	D6	D5	D4	D3	D2	D1	D0
Code	0	0	1	1	1	0	0	0	0	0

**(Note)** During the Read Modify Write mode, any instruction except Column Address Set can be executed.

	<b>PRODUCT SPEC.</b>	<b>MODE NO.</b>	<b>PAGE 16/20</b>
		MC122032B6W-SPR	

**L. Sequence of cursor display**

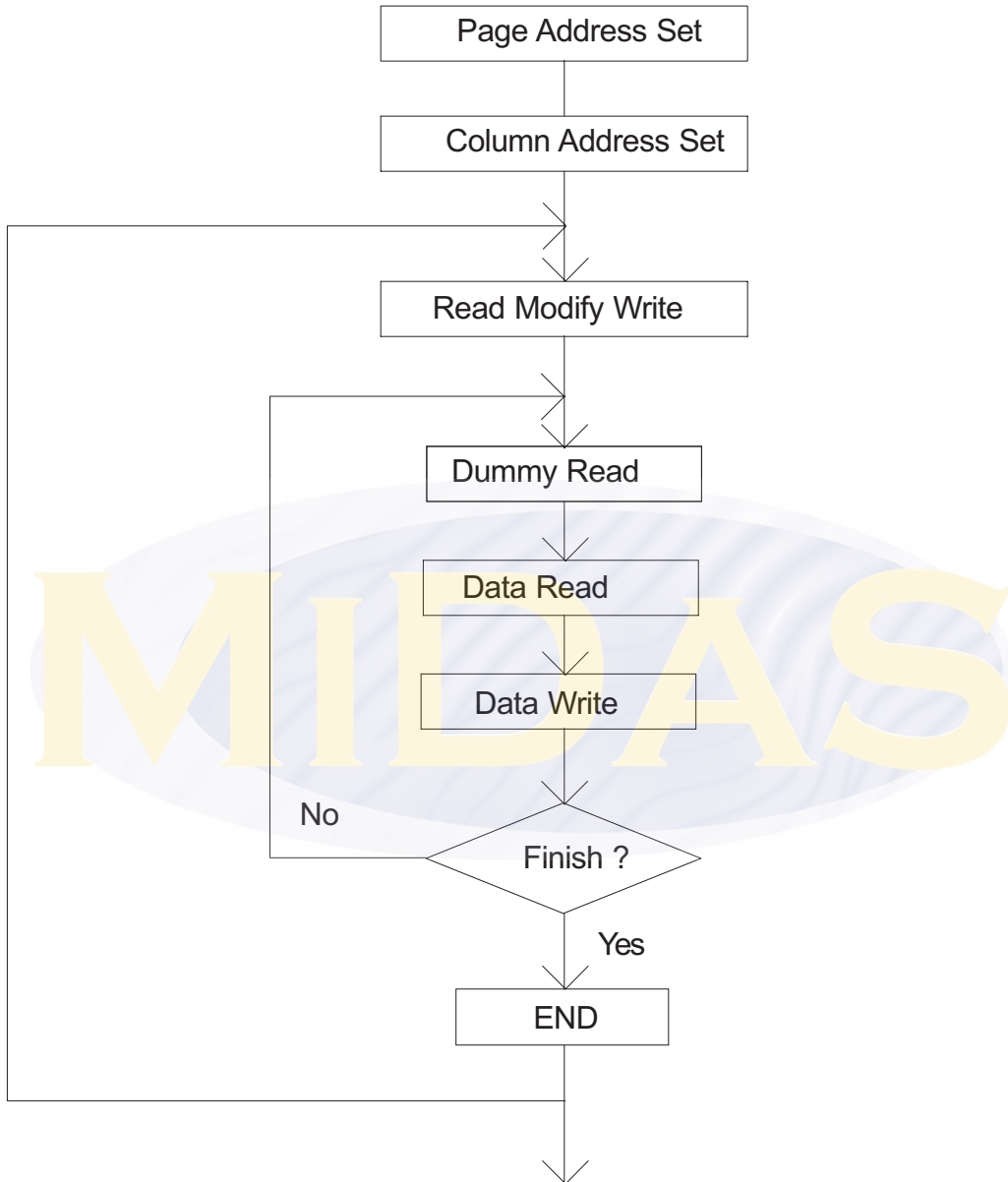

	<b>PRODUCT SPEC.</b>	<b>MODE NO.</b>	<b>PAGE 17/20</b>
		<b>MC122032B6W-SPR</b>	

**M. End**

This instruction release the Read Modify Write mode and the column address back to the address where the Read Modify Write mode setting.

	A0	R/W	D7	D6	D5	D4	D3	D2	D1	D0
Code	0	0	1	1	1	0	1	1	1	0

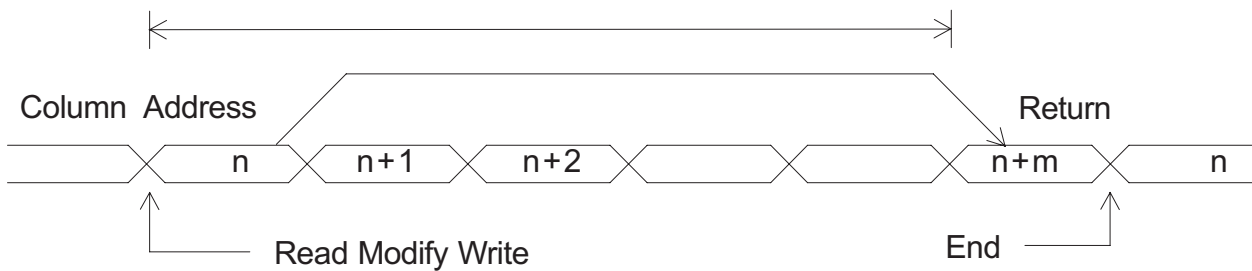

**N. Reset**

This instruction executes the following initialization.

Initialization

- 1) Set the first line in the Display Start Line Register.
- 2) Set the page 3 in the Page Register.

In this time, there are no influence to the Display Data RAM.

	A0	R/W	D7	D6	D5	D4	D3	D2	D1	D0
Code	0	0	1	1	1	0	0	0	1	0

**(Note)** The initialization when the power terms on can not be executed by Reset instruction

**O. Power Save ( Dual Command )**

When both of Display Off and Static Drive On are executed, the internal put on the power save mode and the current consumption is reduced as same as stand by current. The internal status in this mode are as following:

- 1) Stop the LCD driving. Segment and Common drivers output Vdd level
- 2) Stop the oscillation or inhibit the external clock input
- 3) Keeping the display data and operating mode.

The power save mode is released by Display on or static drive off instruction.

	PRODUCT SPEC.	MODE NO.	PAGE 18/20
		MC122032B6W-SPR	

### 13. APPLICATION EXAMPLE

#### Application Flowchart

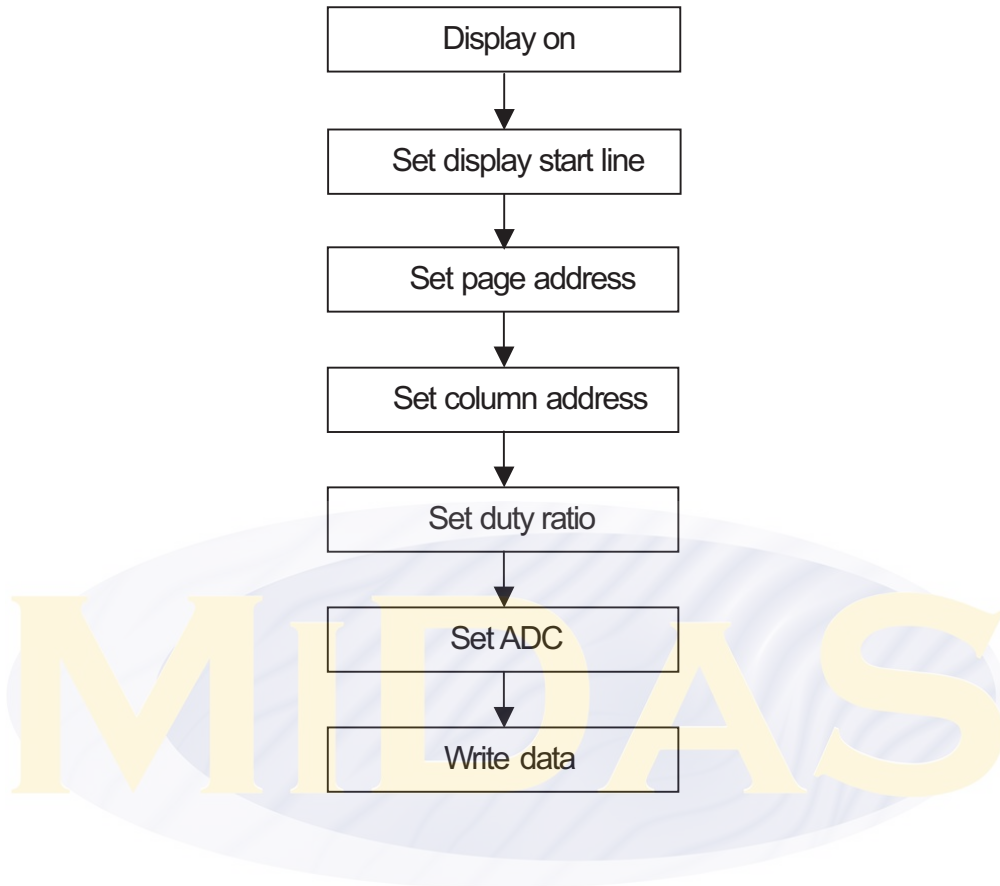

#### Application Circuit

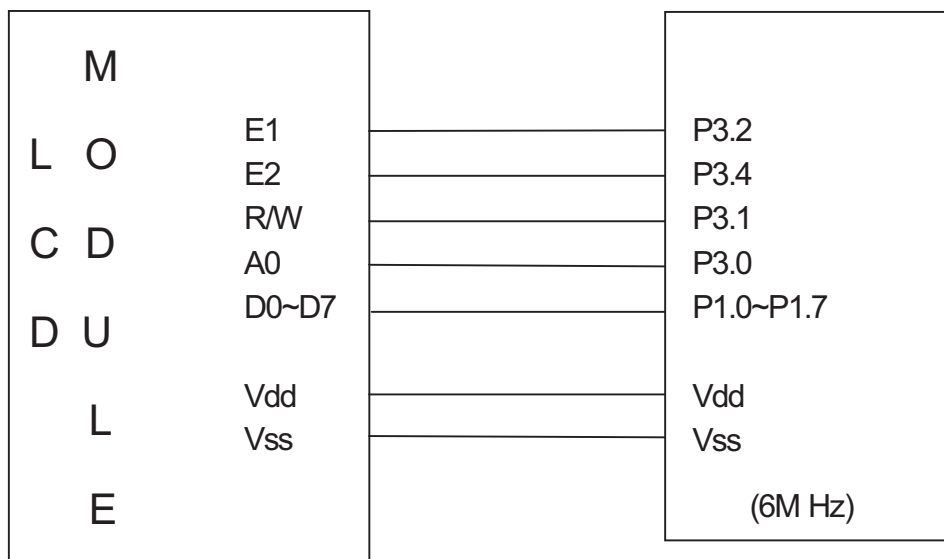

Application Circuit 1

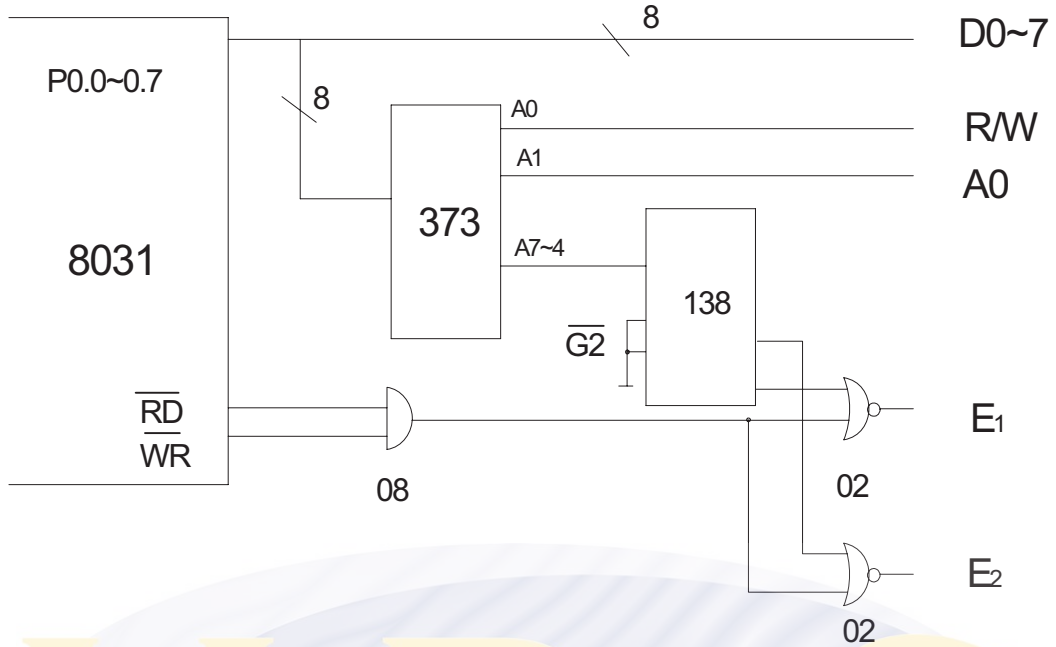

Application Circuit 2

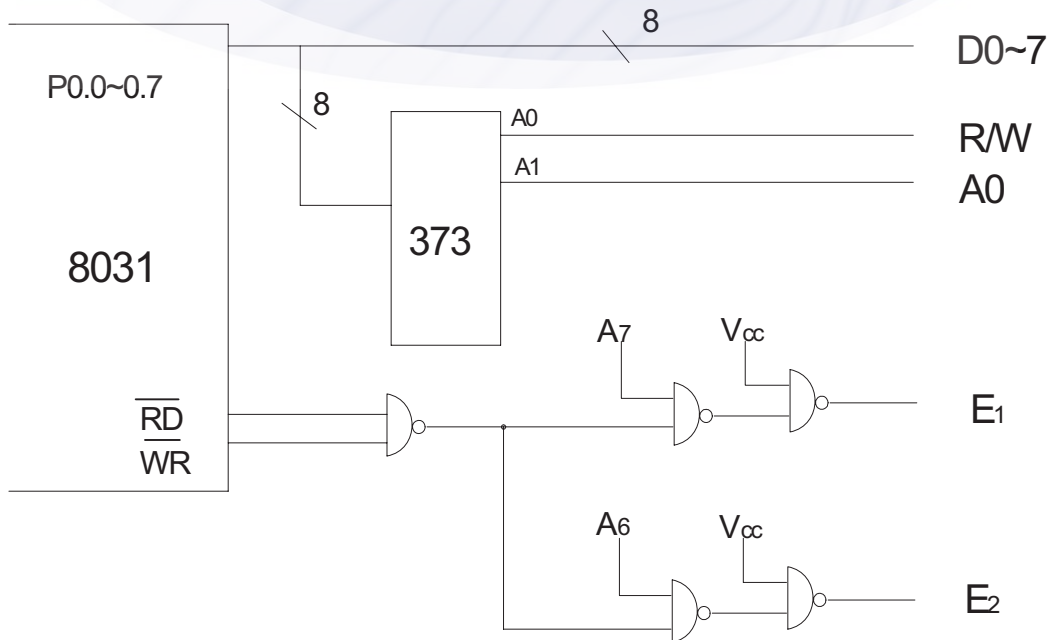

**BOOKBINDING AREA**

	<b>PRODUCT SPEC.</b>	<b>MODE NO.</b>	<b>PAGE 20/20</b>
		MC122032B6W-SPR	

**14. PACKING DETAIL**

WITH LED BKL	WITHOUT LED BKL
45 PCS/BOX	45 PCS/BOX
10 BOXES/CARTON	10 BOXES/CARTON
450 PCS/CARTON	450 PCS/CARTON
20.00 KGS/CTN(G.W.)	18.00 KGS/CTN(G.W.)
0.07 M <sup>3</sup> /CARTON	0.07 M <sup>3</sup> /CARTON

NOTE
1. The weight is estimated for reference only.
2. Packing detail may be changed without notice.

