

# Inductive Sensor M12 Long Housing



## Features:

- Inductive sensor
- Shielded type
- DC 3-wire
- With LED operation indicate lamp, easily identifiable
- Brass chrome plated, proof of oil, water acid, alkaline
- Over-current protection
- Widely applied in measuring, Counting, Rpm measuring in mechanism, chemical, paper manufacture light industry, etc.

## Specifications:

Style	: Cylinder shape
Diameter	: 12mm
Mounting Distance	: Shielded (2mm)
Standard Sensing Object	: Iferrous metals
Protection Rate	: IP67, water resistant
Current Output	: DC: ≤ 200mA / AC: ≤ 300mA
Power Supply	: DC 10V to 30V / AC 90V to 250V
Ambient temperature	: -20°C to +70°C

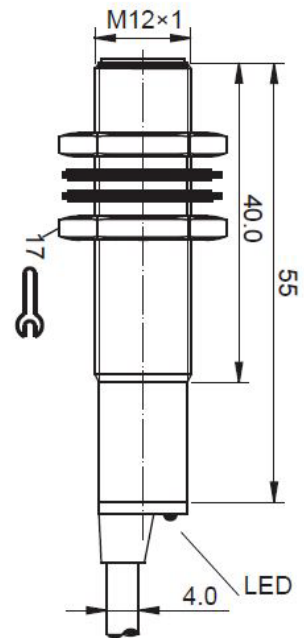

Dimensions : Millimetres

## Electrical Connection Drawing

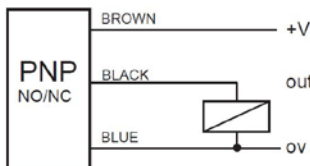

## Part Number Table

Description	Output type	Connector model	Part Number
Inductive Sensor M12 Long Housing	PNP NO	3 Wire	MCPIP-T12L-001
		Straight Plug-in connector	MCPIP-T12L-101
	PNP NC	Straight Plug-in connector	MCPIP-T12L-111
		3 Wire	MCPIP-T12L-011

**Important Notice :** This data sheet and its contents (the "Information") belong to the members of the Premier Farnell group of companies (the "Group") or are licensed to it. No licence is granted for the use of it other than for information purposes in connection with the products to which it relates. No licence of any intellectual property rights is granted. The Information is subject to change without notice and replaces all data sheets previously supplied. The Information supplied is believed to be accurate but the Group assumes no responsibility for its accuracy or completeness, any error in or omission from it or for any use made of it. Users of this data sheet should check for themselves the Information and the suitability of the products for their purpose and not make any assumptions based on information included or omitted. Liability for loss or damage resulting from any reliance on the Information or use of it (including liability resulting from negligence or where the Group was aware of the possibility of such loss or damage arising) is excluded. This will not operate to limit or restrict the Group's liability for death or personal injury resulting from its negligence. Multicomp is the registered trademark of the Group. © Premier Farnell plc 2012.

