

2-Phase, Dual Output Synchronous Boost Controller

FEATURES

- Synchronous Operation for Highest Efficiency and Reduced Heat Dissipation
- Wide Input Range: 4.5V to 38V (40V Abs Max) and Operates Down to 2.5V After Start-Up
- Output Voltages Up to 60V
- $\pm 1\%$ 1.2V Reference Voltage
- R_{SENSE} or Inductor DCR Current Sensing
- 100% Duty Cycle Capability for Synchronous MOSFET
- Low Quiescent Current: 125 μ A
- Phase-Lockable Frequency (75kHz to 850kHz)
- Programmable Fixed Frequency (50kHz to 900kHz)
- Adjustable Output Voltage Soft-Start
- Power Good Output Voltage Monitor
- Low Shutdown Current I_Q : < 8 μ A
- Internal LDO Powers Gate Drive from VBIAS or EXT V_{CC}
- Available in a Narrow SSOP Package

APPLICATIONS

- Industrial
- Automotive
- Medical
- Military

DESCRIPTION

The LTC[®]3788-1 is a high performance 2-phase dual synchronous boost converter controller that drives all N-channel power MOSFETs. Synchronous rectification increases efficiency, reduces power losses and eases thermal requirements, allowing the LTC3788-1 to be used in high power boost applications.

A constant-frequency current mode architecture allows a phase-lockable frequency of up to 850kHz. OPTI-LOOP compensation allows the transient response to be optimized over a wide range of output capacitance and ESR values. The LTC3788-1 features a precision 1.2V reference and a power good output indicator. A 4.5V to 38V input supply range encompasses a wide range of system architectures and battery chemistries.

Independent SS pins for each controller ramp the output voltages during start-up. The PLLIN/MODE pin selects among Burst Mode operation, pulse-skipping mode or continuous inductor current mode at light loads.

For a leadless 32-pin QFN package with additional features of adjustable current limit, clock out, phase modulation and two PGOOD outputs, see the LTC3788 data sheet.

LT, LTC, LTM, Linear Technology, OPTI-LOOP, Burst Mode and the Linear logo are registered trademarks and No R_{SENSE} and ThinSOT are trademarks of Linear Technology Corporation. All other trademarks are the property of their respective owners. Protected by U. S. Patents, including 5408150, 5481178, 5705919, 5929620, 6144194, 6177787, 6580258.

TYPICAL APPLICATION

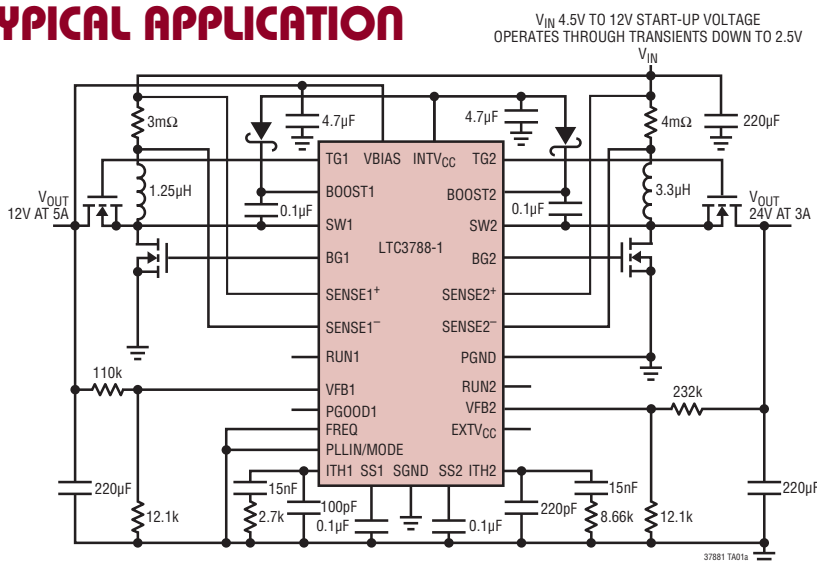

Efficiency and Power Loss vs Load Current

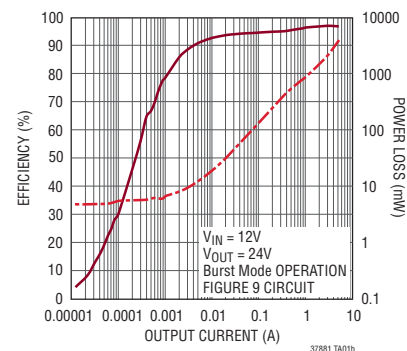

ABSOLUTE MAXIMUM RATINGS

(Note 1)

VBIAS.....	-0.3V to 40V
BOOST1, BOOST2.....	-0.3V to 76V
SW1, SW2.....	-0.3V to 70V
RUN1, RUN2.....	-0.3V to 8V
Maximum Current Sourced into Pin from Source > 8V.....	100µA
PGOOD1, PLLIN/MODE.....	-0.3V to 6V
INTV _{CC} , (BOOST1-SW1, BOOST2-SW2).....	-0.3V to 6V
EXTV _{CC}	-0.3V to 6V
SENSE1 ⁺ , SENSE1 ⁻ , SENSE2 ⁺ , SENSE2 ⁻	-0.3V to 40V
SENSE1 ⁺ – SENSE1 ⁻ , SENSE2 ⁺ – SENSE2 ⁻	-0.3V to 0.3V
SS1, SS2, ITH1, ITH2, FREQ, VFB1, VFB2.....	-0.3V to INTV _{CC}
Operating Junction Temperature Range ...	-40°C to 125°C
Storage Temperature Range.....	-65°C to 125°C
Lead Temperature (Soldering, 10 seconds)	300°C

PIN CONFIGURATION

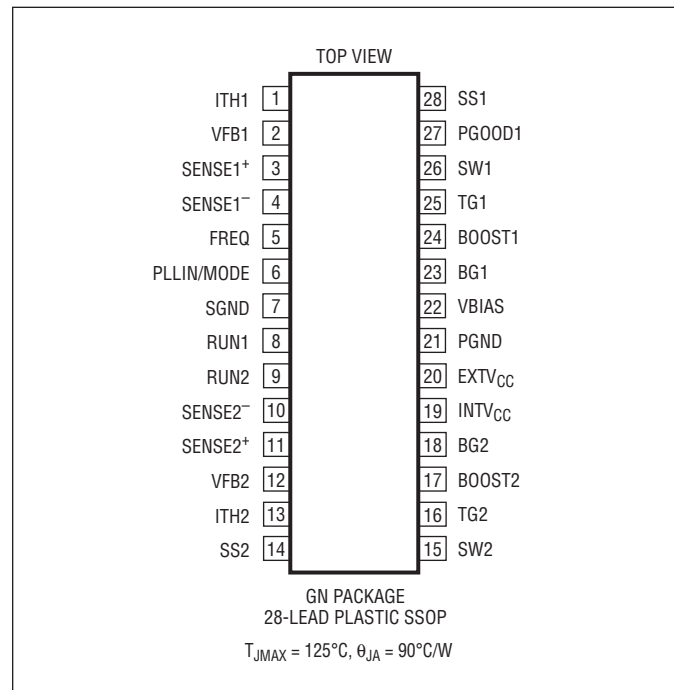

ORDER INFORMATION

LEAD FREE FINISH	TAPE AND REEL	PART MARKING*	PACKAGE DESCRIPTION	TEMPERATURE RANGE
LTC3788EGN-1#PBF	LTC3788EGN-1#TRPBF	LTC3788GN-1	28-Lead Plastic SSOP	-40°C to 125°C
LTC3788IGN-1#PBF	LTC3788IGN-1#TRPBF	LTC3788GN-1	28-Lead Plastic SSOP	-40°C to 125°C

Consult LTC Marketing for parts specified with wider operating temperature ranges. *The temperature grade is identified by a label on the shipping container.

For more information on lead free part marking, go to: <http://www.linear.com/leadfree/>

For more information on tape and reel specifications, go to: <http://www.linear.com/tapeandreeel/>

ELECTRICAL CHARACTERISTICS

The ● denotes the specifications which apply over the full operating junction temperature range, otherwise specifications are at T_A = 25°C, VBIAS = 12V, unless otherwise noted (Note 2).

SYMBOL	PARAMETER	CONDITIONS	MIN	TYP	MAX	UNITS
Main Control Loop						
VBIAS	Chip Bias Voltage Operating Range		4.5		38	V
VFB1,2	Regulated Feedback Voltage	I _{TH} = 1.2V (Note 4)	● 1.188	1.200	1.212	V
IFB1,2	Feedback Current	(Note 4)		±5	±50	nA
V _{REFLNREG}	Reference Line Voltage Regulation	V _{IN} = 6V to 38V		0.002	0.02	%/V

ELECTRICAL CHARACTERISTICS

The ● denotes the specifications which apply over the full operating junction temperature range, otherwise specifications are at $T_A = 25^\circ\text{C}$, $V_{BIAS} = 12\text{V}$, unless otherwise noted (Note 2).

SYMBOL	PARAMETER	CONDITIONS	MIN	TYP	MAX	UNITS	
$V_{LOADREG}$	Output Voltage Load Regulation	(Note 4)					
		Measured in Servo Loop; ΔI_{TH} Voltage = 1.2V to 0.7V	●	0.01	0.1	%	
		Measured in Servo Loop; ΔI_{TH} Voltage = 1.2V to 2V	●	-0.01	-0.1	%	
$g_{m1,2}$	Error Amplifier Transconductance	$I_{TH} = 1.2\text{V}$		2		mmho	
I_Q	Input DC Supply Current	(Note 5)					
	Pulse-Skipping or Forced Continuous Mode (One Channel On)	$RUN1 = 5\text{V}$ and $RUN2 = 0\text{V}$ or $RUN1 = 0\text{V}$ and $RUN2 = 5\text{V}$; $V_{FB1(2)} = 1.25\text{V}$ (No Load)		0.9		mA	
	Pulse-Skipping or Forced Continuous Mode (Both Channels On)	$RUN1,2 = 5\text{V}$; $V_{FB1,2} = 1.25\text{V}$ (No Load)		1.2		mA	
	Sleep Mode (One Channel On)	$RUN1 = 5\text{V}$ and $RUN2 = 0\text{V}$ or $RUN1 = 0\text{V}$ and $RUN2 = 5\text{V}$; $V_{FB1(2)} = 1.25\text{V}$ (No Load)		125	190	μA	
	Sleep Mode (Both Channels On)	$RUN1,2 = 5\text{V}$; $V_{FB1,2} = 1.25\text{V}$ (No Load)		200	300	μA	
	Shutdown	$RUN1,2 = 0\text{V}$		8	20	μA	
UVLO	INTV _{CC} Undervoltage Lockout Thresholds	V _{INTVCC} Ramping Up	●	4.1	4.3	V	
		V _{INTVCC} Ramping Down	●	3.6	3.8	V	
$V_{RUN1,2}$	RUN Pin On Threshold	V_{RUN} Rising	●	1.18	1.28	1.38	V
V_{RUNHYS}	RUN Pin Hysteresis			100		mV	
$I_{RUN1,2}$	RUN Pin Hysteresis Current	$V_{RUN} > 1.28\text{V}$		4.5		μA	
$I_{RUN1,2}$	RUN Pin Current	$V_{RUN} < 1.28\text{V}$		0.5		μA	
$I_{SS1,2}$	Soft-Start Charge Current	$V_{SS} = \text{GND}$		10		μA	
$V_{SENSE(\text{MAX})}$	Maximum Current Sense Threshold	$V_{FB} = 1.1\text{V}$	●	68	75	82	mV
$V_{SENSE(\text{CM})}$	SENSE Pins Common Mode Range (BOOST Converter Input Supply Voltage V_{IN})			2.5		38	V
$I_{SENSE1,2^+}$	SENSE ⁺ Pin Current	$V_{FB} = 1.1\text{V}$, $I_{LIM} = \text{Float}$		200	300	μA	
$I_{SENSE1,2^-}$	SENSE ⁻ Pin Current	$V_{FB} = 1.1\text{V}$, $I_{LIM} = \text{Float}$			±1	μA	
$t_r(\text{TG1,2})$	Top Gate Rise Time	$C_{LOAD} = 3300\text{pF}$ (Note 6)		20		ns	
$t_f(\text{TG1,2})$	Top Gate Fall Time	$C_{LOAD} = 3300\text{pF}$ (Note 6)		20		ns	
$t_r(\text{BG1,2})$	Bottom Gate Rise Time	$C_{LOAD} = 3300\text{pF}$ (Note 6)		20		ns	
$t_f(\text{BG1,2})$	Bottom Gate Fall Time	$C_{LOAD} = 3300\text{pF}$ (Note 6)		20		ns	
$R_{UP(\text{TG1,2})}$	Top Gate Pull-Up Resistance			1.5		Ω	
$R_{DN(\text{TG1,2})}$	Top Gate Pull-Down Resistance			1.5		Ω	
$R_{UP(\text{BG1,2})}$	Bottom Gate Pull-Up Resistance			1.5		Ω	
$R_{DN(\text{BG1,2})}$	Bottom Gate Pull-Down Resistance			1.5		Ω	
$t_D(\text{TG/BG})$	Top Gate Off to Bottom Gate On Switch-On Delay Time	$C_{LOAD} = 3300\text{pF}$ (Each Driver)		70		ns	
$t_D(\text{BG/TG})$	Bottom Gate Off to Top Gate On Switch-On Delay Time	$C_{LOAD} = 3300\text{pF}$ (Each Driver)		70		ns	
$DF_{\text{MAX}(\text{BG1,2})}$	Maximum BG Duty Factor			96		%	
$t_{\text{ON}(\text{MIN})}$	Minimum BG On-Time	(Note 7)		110		ns	

ELECTRICAL CHARACTERISTICS

The ● denotes the specifications which apply over the full operating junction temperature range, otherwise specifications are at $T_A = 25^\circ\text{C}$, $V_{\text{BIAS}} = 12\text{V}$, unless otherwise noted (Note 2).

SYMBOL	PARAMETER	CONDITIONS	MIN	TYP	MAX	UNITS
INTV_{CC} Linear Regulator						
$V_{\text{INTVCCVIN}}$	Internal V_{CC} Voltage	$6\text{V} < V_{\text{BIAS}} < 38\text{V}$, $V_{\text{EXTVCC}} = 0\text{V}$	5.2	5.4	5.6	V
V_{LDOVIN}	INTV _{CC} Load Regulation	$I_{\text{CC}} = 0\text{mA}$ to 50mA , $V_{\text{EXTVCC}} = 0\text{V}$		0.5	2	%
$V_{\text{INTVCCEXT}}$	Internal V_{CC} Voltage	$V_{\text{EXTVCC}} = 6\text{V}$	5.2	5.4	5.6	V
V_{LDOEXT}	INTV _{CC} Load Regulation	$I_{\text{CC}} = 0\text{mA}$ to 40mA , $V_{\text{EXTVCC}} = 6\text{V}$		0.5	2	%
V_{EXTVCC}	EXTV _{CC} Switchover Voltage	EXTV _{CC} Ramping Positive	4.5	4.8	5	V
V_{LDOHYS}	EXTV _{CC} Hysteresis			250		mV
Oscillator and Phase-Locked Loop						
f_{PROG}	Programmable Frequency	$R_{\text{FREQ}} = 25\text{k}$		105		kHz
		$R_{\text{FREQ}} = 60\text{k}$	335	400	465	kHz
		$R_{\text{FREQ}} = 100\text{k}$		760		kHz
f_{LOW}	Lowest Fixed Frequency	$V_{\text{FREQ}} = 0\text{V}$	320	350	380	kHz
f_{HIGH}	Highest Fixed Frequency	$V_{\text{FREQ}} = \text{INTV}_{\text{CC}}$	485	535	585	kHz
f_{SYNC}	Synchronizable Frequency	PLLIN/MODE = External Clock	● 75		850	kHz
PGOOD1 and PGOOD2 Outputs						
V_{PGL}	PGOOD Voltage Low	$I_{\text{PGOOD}} = 2\text{mA}$		0.2	0.4	V
I_{PGOOD}	PGOOD Leakage Current	$V_{\text{PGOOD}} = 5\text{V}$			±1	μA
V_{PG}	PGOOD Trip Level	V_{FB} with Respect to Set Regulated Voltage				
		V_{FB} Ramping Negative	-12	-10	-8	%
		Hysteresis		2.5		%
		V_{FB} Ramping Positive	8	10	12	%
		Hysteresis		2.5		%
$t_{\text{PGOOD(DELAY)}}$	PGOOD Delay	PGOOD Going High to Low		25		μs
BOOST1 and BOOST2 Charge Pump						
$I_{\text{BOOST1,2}}$	BOOST Charge Pump Available Output Current	$V_{\text{SW1,2}} = 12\text{V}$; $V_{\text{BOOST1,2}} - V_{\text{SW1,2}} = 4.5\text{V}$; $\text{FREQ} = 0\text{V}$, Forced Continuous or Pulse-Skipping Mode		55		μA

Note 1: Stresses beyond those listed under Absolute Maximum Ratings may cause permanent damage to the device. Exposure to any Absolute Maximum Rating condition for extended periods may affect device reliability and lifetime.

Note 2: The LTC3788E-1 is guaranteed to meet specifications from 0°C to 85°C . Specifications over the -40°C to 125°C operating junction temperature range are assured by design, characterization and correlation with statistical process controls. The LTC3788I-1 is guaranteed over the full -40°C to 125°C operating junction temperature range.

Note 3: T_J is calculated from the ambient temperature T_A and power dissipation P_D according to the formula: $T_J = T_A + (P_D \cdot 90^\circ\text{C/W})$

Note 4: The LTC3788-1 is tested in a feedback loop that serves V_{FB} to the output of the error amplifier while maintaining I_{TH} at the midpoint of the current limit range.

Note 5: Dynamic supply current is higher due to the gate charge being delivered at the switching frequency.

Note 6: Rise and fall times are measured using 10% and 90% levels. Delay times are measured using 50% levels.

Note 7: See Minimum On-Time Considerations in the Applications Information section.

TYPICAL PERFORMANCE CHARACTERISTICS

Efficiency and Power Loss vs Output Current

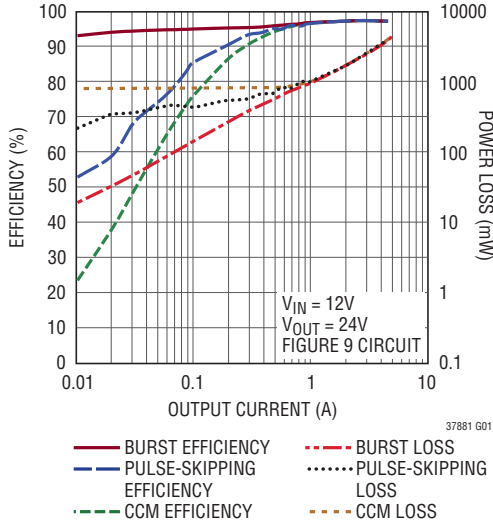

Efficiency and Power Loss vs Output Current

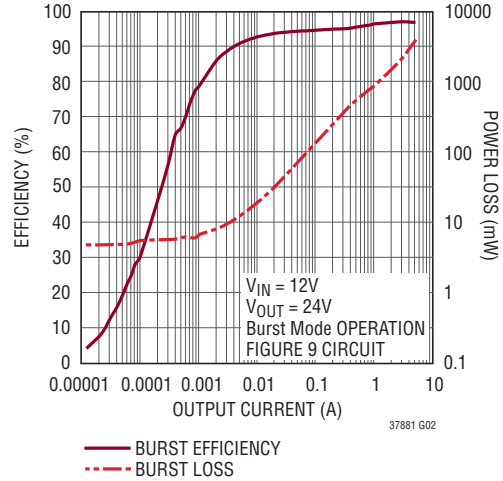

Efficiency vs Input Voltage

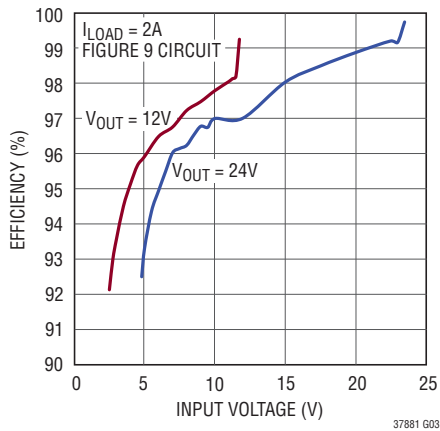

**Load Step
Forced Continuous Mode**

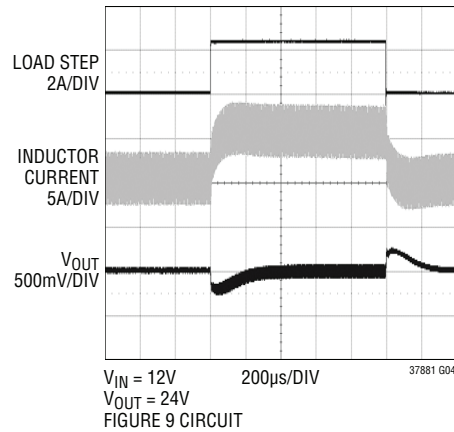

**Load Step
Burst Mode Operation**

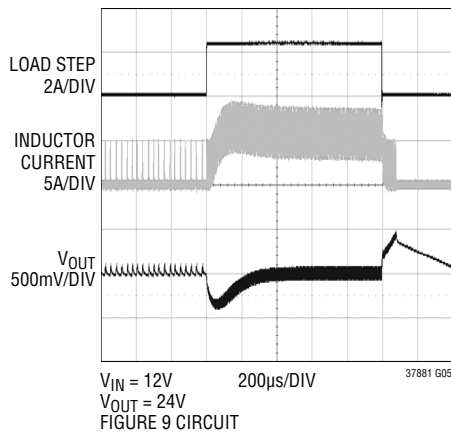

**Load Step
Pulse-Skipping Mode**

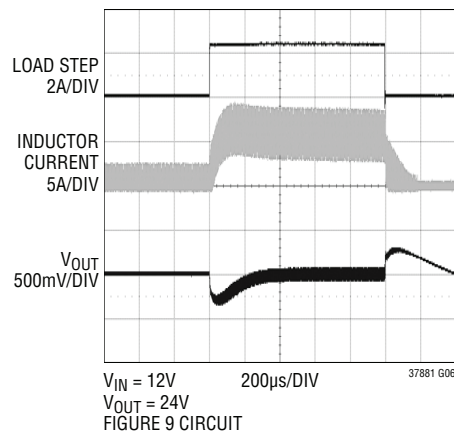

TYPICAL PERFORMANCE CHARACTERISTICS

Inductor Current at Light Load

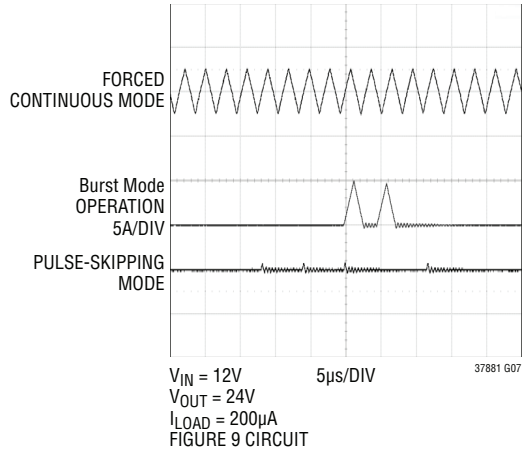

Soft Start-Up

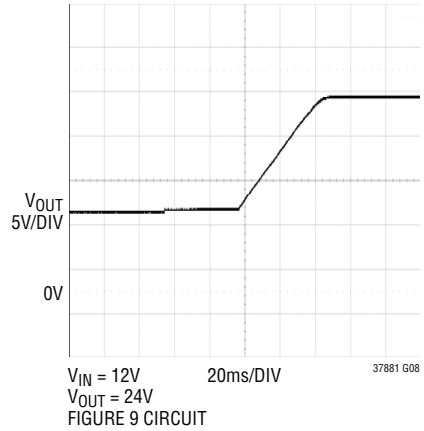

Regulated Feedback Voltage vs Temperature

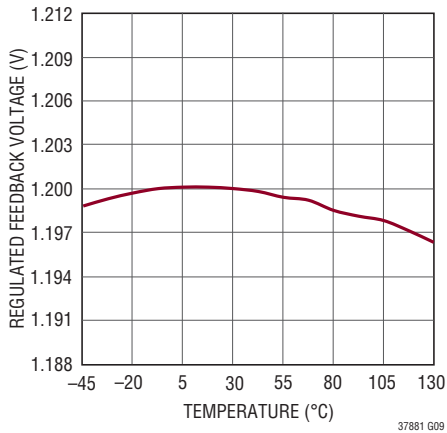

Soft-Start Pull-Up Current vs Temperature

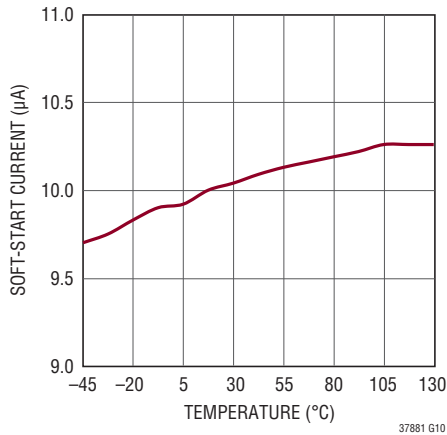

Shutdown Current vs Temperature

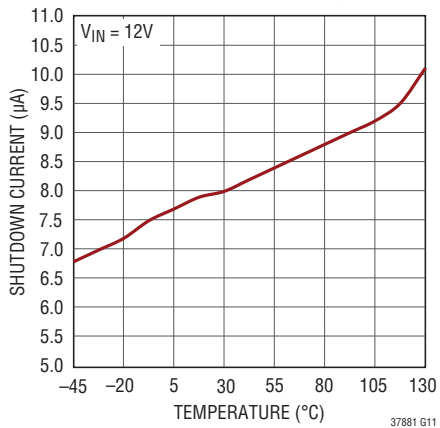

Shutdown Current vs Input Voltage

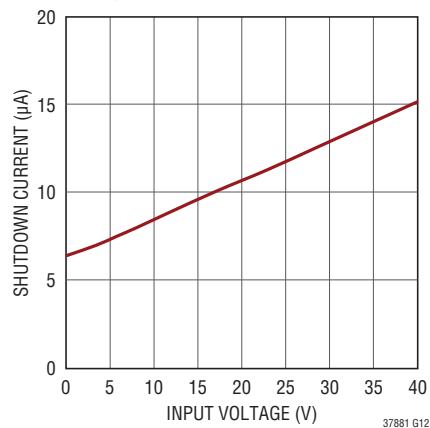

TYPICAL PERFORMANCE CHARACTERISTICS

Quiescent Current vs Temperature

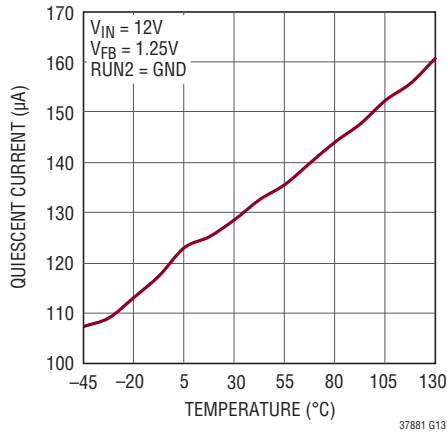

Shutdown (RUN) Threshold vs Temperature

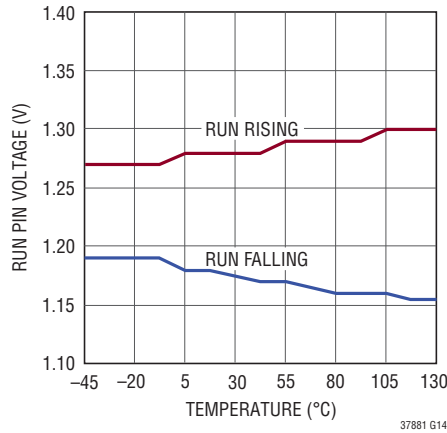

Undervoltage Lockout Threshold vs Temperature

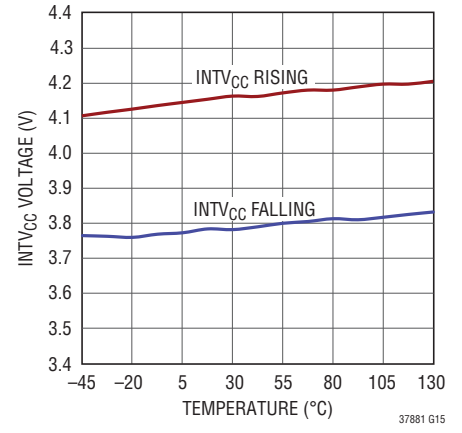

INTV_{CC} Line Regulation

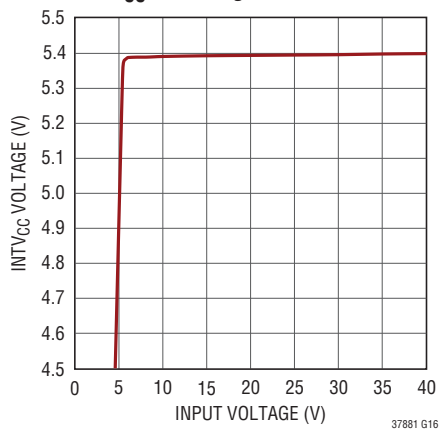

EXTV_{CC} Switchover and INTV_{CC} Voltages vs Temperature

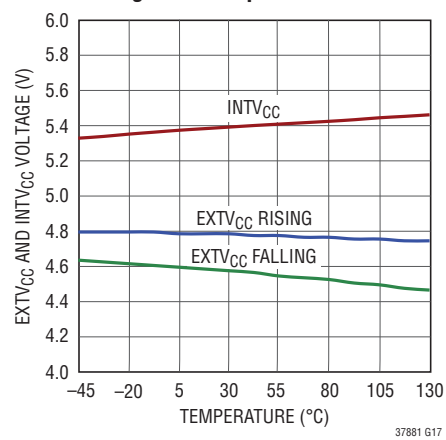

INTV_{CC} vs INTV_{CC} Load Current

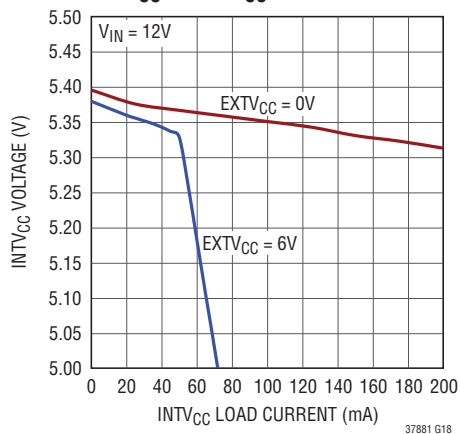

Oscillator Frequency vs Temperature

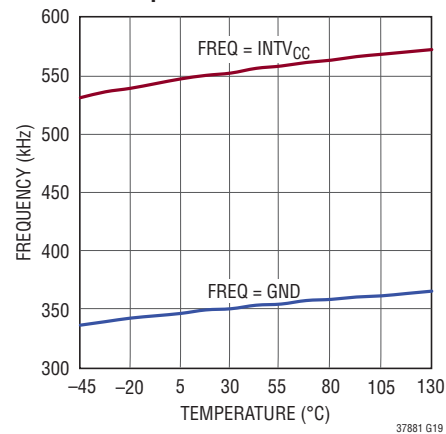

TYPICAL PERFORMANCE CHARACTERISTICS

Oscillator Frequency vs Input Voltage

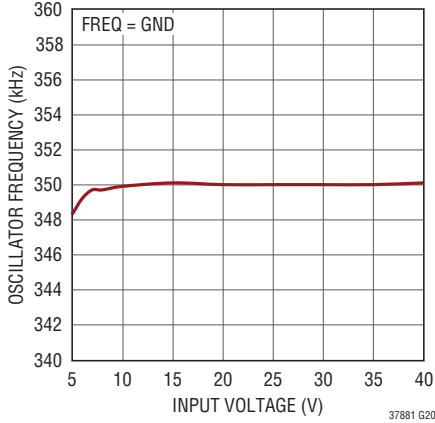

Maximum Current Sense Threshold vs I_{TH} Voltage

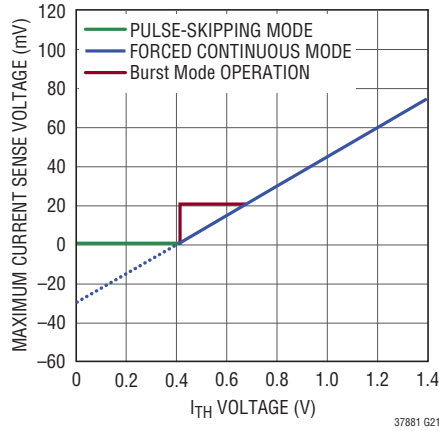

SENSE Pin Input Current vs Temperature

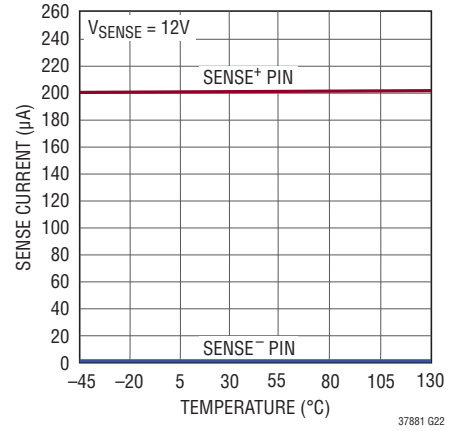

SENSE Pin Input Current vs I_{TH} Voltage

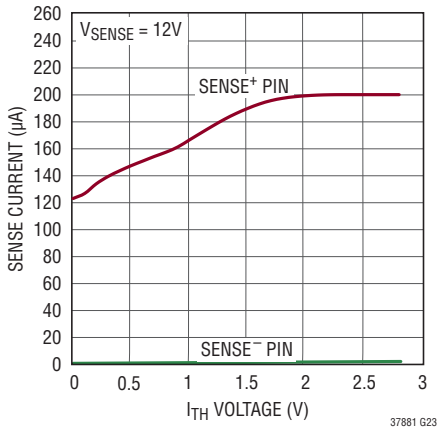

SENSE Pin Input Current vs V_{SENSE} Voltage

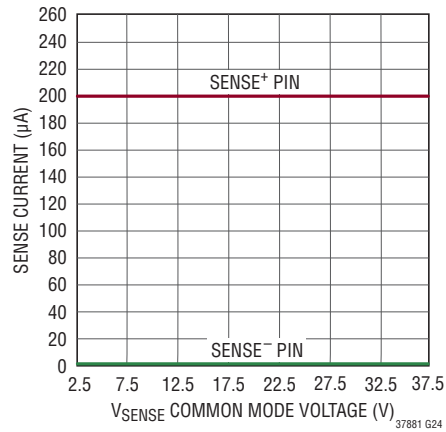

Maximum Current Sense Threshold vs Duty Cycle

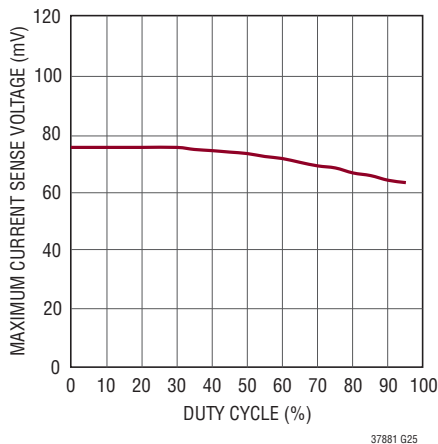

Charge Pump Charging Current vs Operating Frequency

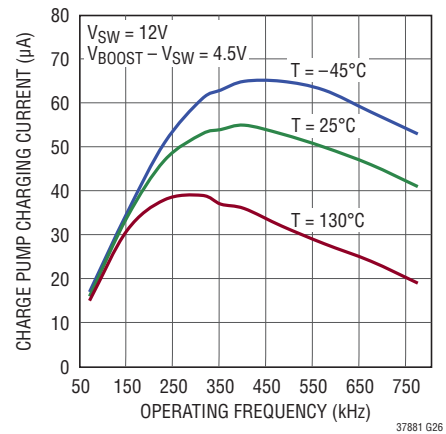

PIN FUNCTIONS

ITH1, ITH2 (Pin 1, Pin 13): Current Control Threshold and Error Amplifier Compensation Point. The voltage on this pin sets the current trip threshold.

VFB1, VFB2 (Pin 2, Pin 12): Error Amplifier Feedback Input. This pin receives the remotely sensed feedback voltage from an external resistive divider connected across the output.

SENSE1+, SENSE2+ (Pin 3, Pin 11): Positive Current Sense Comparator Input. The (+) input to the current comparator is normally connected to the positive terminal of a current sense resistor. The current sense resistor is normally placed at the input of the boost controller in series with the inductor. This pin also supplies power to the current comparator.

SENSE1-, SENSE2- (Pin 4, Pin 10): Negative Current Sense Comparator Input. The (-) input to the current comparator is normally connected to the negative terminal of a current sense resistor connected in series with the inductor. The common mode voltage range on these pins is 2.5V to 38V (40V abs max).

FREQ (Pin 5): The frequency control pin for the internal VCO. Connecting the pin to GND forces the VCO to a fixed low frequency of 350kHz. Connecting the pin to INTV_{CC} forces the VCO to a fixed high frequency of 535kHz. The frequency can be programmed from 50kHz to 900kHz by connecting a resistor from the FREQ pin to GND. The resistor and an internal 20μA source current create a voltage used by the internal oscillator to set the frequency. Alternatively, this pin can be driven with a DC voltage to vary the frequency of the internal oscillator.

PLLIN/MODE (Pin 6): Forced Continuous Mode, Burst Mode or Pulse-Skipping Mode Selection Pin and External Synchronization Input to Phase Detector Pin. Pulling this pin to ground selects Burst Mode operation. Tying this pin to INTV_{CC} forces continuous inductor current operation. Tying this pin to a voltage greater than 1.2V and less than INTV_{CC} - 1.3V selects pulse-skipping operation. A clock on the pin will force the controller into pulse-skipping mode of operation and synchronize the internal oscillator.

SGND (Pin 7): Signal Ground. All small-signal components and compensation components should connect to this ground, which in turn connects to PGND at a single point.

RUN1, RUN2 (Pin 8, Pin 9): Run Control Input. An external resistor divider connects to V_{IN} and sets the thresholds for converter operation with a threshold of 1.28V. Once running, a 4.5μA current is sourced from the RUN pin allowing the user to program hysteresis using the resistor values.

INTV_{CC} (Pin 19): Output of Internal 5.4V LDO. Power supply for control circuits and gate drives. Decouple this pin to GND with a minimum 4.7μF low ESR tantalum or ceramic capacitor.

EXTV_{CC} (Pin 20): External Power Input. When this pin is higher than 4.8V an internal switch bypasses the internal regulator and supply power to INTV_{CC} directly from EXTV_{CC}.

PGND (Pin 21): Driver Power Ground. Connects to the sources of bottom (main) N-channel MOSFETs and the (-) terminal(s) of C_{IN} and C_{OUT}.

VBIAS (Pin 22): Main Supply Pin. It is normally tied to the input supply V_{IN} or to the output of the boost converter. A bypass capacitor should be tied between this pin and the signal ground pin. The operating voltage range on this pin is 4.5V to 38V (40V abs max).

BG1, BG2 (Pin 23, Pin 18): Bottom Gate. Connect to the gate of the main NMOS.

BOOST1, BOOST2 (Pin 24, Pin 17): Floating power supply for the synchronous NMOS. Bypass to SW with a capacitor and supply with a Schottky diode connected to INTV_{CC}.

TG1, TG2 (Pin 25, Pin 16): Top Gate. Connect to the gate of the synchronous NMOS.

SW1, SW2 (Pin 26, Pin 15): Switch Node. Connect to the source of the synchronous NMOS, the drain of the main NMOS and the inductor.

PGOOD1 (Pin 27): Power Good Indicator for Channel 1. Open-drain logic output that is pulled to ground when the output voltage is more than ±10% away from the regulated output voltage. To avoid false trips the output voltage must be outside the range for 25μs before this output is activated.

SS1, SS2 (Pin 28, Pin 14): Output Soft-Start Input. A capacitor to ground at this pin sets the ramp rate of the output voltage during start-up.

OPERATION (Refer to Block Diagram)

Main Control Loop

The LTC3788-1 uses a constant-frequency, current mode step-up architecture with the two controller channels operating 180 degrees out-of-phase. During normal operation, each external bottom MOSFET is turned on when the clock for that channel sets the RS latch, and is turned off when the main current comparator, ICMP, resets the RS latch. The peak inductor current at which ICMP trips and resets the latch is controlled by the voltage on the ITH pin, which is the output of the error amplifier EA. The error amplifier compares the output voltage feedback signal at the VFB pin, (which is generated with an external resistor divider connected across the output voltage, V_{OUT} , to ground) to the internal 1.200V reference voltage. When the load current increases, it causes a slight decrease in V_{FB} relative to the reference, which causes the EA to increase the I_{TH} voltage until the average inductor current matches the new load current.

After the bottom MOSFET is turned off each cycle, the top MOSFET is turned on until either the inductor current starts to reverse, as indicated by the current comparator IR, or the beginning of the next clock cycle.

INTV_{CC}/EXTV_{CC} Power

Power for the top and bottom MOSFET drivers and most other internal circuitry is derived from the INTV_{CC} pin. When the EXTV_{CC} pin is left open or tied to a voltage less than 4.8V, the VBIAS LDO (low dropout linear regulator) supplies 5.4V from VBIAS to INTV_{CC}. If EXTV_{CC} is taken above 4.8V, the VBIAS LDO is turned off and an EXTV_{CC} LDO is turned on. Once enabled, the EXTV_{CC} LDO supplies 5.4V from EXTV_{CC} to INTV_{CC}. Using the EXTV_{CC} pin allows the INTV_{CC} power to be derived from a high efficiency external source such as one of the LTC3788-1 switching regulator outputs.

Shutdown and Start-Up (RUN1, RUN2 and SS1, SS2 Pins)

The two channels of the LTC3788-1 can be independently shut down using the RUN1 and RUN2 pins. Pulling either of these pins below 1.28V shuts down the main control loop for that controller. Pulling both pins below 0.7V disables both controllers and most internal circuits, including the

INTV_{CC} LDO's. In this state, the LTC3788-1 draws only 8 μ A of quiescent current.

The RUN pin may be externally pulled up or driven directly by logic. When driving the RUN pin with a low impedance source, do not exceed the absolute maximum rating of 8V. The RUN pin has an internal 11V voltage clamp that allows the RUN pin to be connected through a resistor to a higher voltage (for example, V_{IN}), as long as the maximum current into the RUN pin does not exceed 100 μ A.

The start-up of each controller's output voltage V_{OUT} is controlled by the voltage on the SS pin for that channel. When the voltage on the SS pin is less than the 1.2V internal reference, the LTC3788-1 regulates the V_{FB} voltage to the SS pin voltage instead of the 1.2V reference. This allows the SS pin to be used to program a soft-start by connecting an external capacitor from the SS pin to SGND. An internal 10 μ A pull-up current charges this capacitor creating a voltage ramp on the SS pin. As the SS voltage rises linearly from 0V to 1.2V (and beyond up to INTV_{CC}), the output voltage V_{OUT} rises smoothly to its final value.

Light Load Current Operation—Burst Mode Operation, Pulse-Skipping or Continuous Conduction (PLLIN/MODE Pin)

The LTC3788-1 can be enabled to enter high efficiency Burst Mode operation, constant-frequency pulse-skipping mode or forced continuous conduction mode at low load currents. To select Burst Mode operation, tie the PLLIN/ MODE pin to a ground (e.g., SGND). To select forced continuous operation, tie the PLLIN/MODE pin to INTV_{CC}. To select pulse-skipping mode, tie the PLLIN/MODE pin to a DC voltage greater than 1.2V and less than INTV_{CC} – 0.5V.

When a controller is enabled for Burst Mode operation, the minimum peak current in the inductor is set to approximately 30% of the maximum sense voltage even though the voltage on the ITH pin indicates a lower value. If the average inductor current is higher than the load current, the error amplifier EA will decrease the voltage on the ITH pin. When the I_{TH} voltage drops below 0.425V, the internal sleep signal goes high (enabling sleep mode) and both external MOSFETs are turned off.

OPERATION

In sleep mode, much of the internal circuitry is turned off, reducing the quiescent current that the LTC3788-1 draws. If one channel is shut down and the other channel is in sleep mode, the LTC3788-1 draws only 125 μ A of quiescent current. If both channels are in sleep mode, the LTC3788-1 draws only 200 μ A of quiescent current. In sleep mode, the load current is supplied by the output capacitor. As the output voltage decreases, the EA's output begins to rise. When the output voltage drops enough, the ITH pin is reconnected to the output of the EA, the sleep signal goes low, and the controller resumes normal operation by turning on the bottom external MOSFET on the next cycle of the internal oscillator.

When a controller is enabled for Burst Mode operation, the inductor current is not allowed to reverse. The reverse current comparator (IR) turns off the top external MOSFET just before the inductor current reaches zero, preventing it from reversing and going negative. Thus, the controller operates in discontinuous current operation.

In forced continuous operation or when clocked by an external clock source to use the phase-locked loop (see the Frequency Selection and Phase-Locked Loop section), the inductor current is allowed to reverse at light loads or under large transient conditions. The peak inductor current is determined by the voltage on the ITH pin, just as in normal operation. In this mode, the efficiency at light loads is lower than in Burst Mode operation. However, continuous operation has the advantages of lower output voltage ripple and less interference to audio circuitry, as it maintains constant-frequency operation independent of load current.

When the PLLIN/MODE pin is connected for pulse-skipping mode, the LTC3788-1 operates in PWM pulse-skipping mode at light loads. In this mode, constant-frequency operation is maintained down to approximately 1% of designed maximum output current. At very light loads, the current comparator I_{CMP} may remain tripped for several cycles and force the external bottom MOSFET to stay off for the same number of cycles (i.e., skipping pulses). The inductor current is not allowed to reverse (discontinuous operation). This mode, like forced continuous operation, exhibits low output ripple as well as low audio noise and reduced RF interference as compared to Burst Mode operation. It provides higher low current efficiency than

forced continuous mode, but not nearly as high as Burst Mode operation.

Frequency Selection and Phase-Locked Loop (FREQ and PLLIN/MODE Pins)

The selection of switching frequency is a trade-off between efficiency and component size. Low frequency operation increases efficiency by reducing MOSFET switching losses, but requires larger inductance and/or capacitance to maintain low output ripple voltage.

The switching frequency of the LTC3788-1's controllers can be selected using the FREQ pin.

If the PLLIN/MODE pin is not being driven by an external clock source, the FREQ pin can be tied to SGND, tied to INTV_{CC}, or programmed through an external resistor. Tying FREQ to SGND selects 350kHz while tying FREQ to INTV_{CC} selects 535kHz. Placing a resistor between FREQ and SGND allows the frequency to be programmed between 50kHz and 900kHz, as shown in Figure 6.

A phase-locked loop (PLL) is available on the LTC3788-1 to synchronize the internal oscillator to an external clock source that is connected to the PLLIN/MODE pin. The LTC3788-1's phase detector adjusts the voltage (through an internal lowpass filter) of the VCO input to align the turn-on of the first controller's external bottom MOSFET to the rising edge of the synchronizing signal. Thus, the turn-on of the second controller's external bottom MOSFET is 180 degrees out-of-phase to the rising edge of the external clock source.

The VCO input voltage is prebiased to the operating frequency set by the FREQ pin before the external clock is applied. If prebiased near the external clock frequency, the PLL loop only needs to make slight changes to the VCO input in order to synchronize the rising edge of the external clock's to the rising edge of BG1. The ability to prebias the loop filter allows the PLL to lock-in rapidly without deviating far from the desired frequency.

The typical capture range of the LTC3788-1's PLL is from approximately 55kHz to 1MHz, and is guaranteed to lock to an external clock source whose frequency is between 75kHz and 850kHz.

The typical input clock thresholds on the PLLIN/MODE pin are 1.6V (rising) and 1.2V (falling).

37881f

OPERATION

Operation When $V_{IN} > V_{OUT}$

When V_{IN} rises above the regulated V_{OUT} voltage, the boost controller can behave differently depending on the mode, inductor current and V_{IN} voltage. In forced continuous mode, the loop works to keep the top MOSFET on continuously once V_{IN} rises above V_{OUT} . The internal charge pump delivers current to the boost capacitor to maintain a sufficiently high TG voltage.

In pulse-skipping mode, if V_{IN} is between 100% and 110% of the regulated V_{OUT} voltage, TG turns on if the inductor current rises above a certain threshold and turns off if the inductor current falls below this threshold. This threshold current is set approximately to 4% of the maximum current. If the controller is programmed to Burst Mode operation under this same V_{IN} window, then TG remains off regardless of the inductor current.

If V_{IN} rises above 110% of the regulated V_{OUT} voltage in any mode, the controller turns on TG regardless of the inductor current. In Burst Mode operation, however, the internal charge pump turns off if the entire chip is asleep (the other channel is asleep or shut down). With the charge pump off, there would be nothing to prevent the boost capacitor from discharging, resulting in an insufficient TG voltage needed to keep the top MOSFET completely on. To prevent excessive power dissipation across the body diode of the top MOSFET in this situation, the chip can be switched over to forced continuous mode to enable the charge pump, or a Schottky diode can also be placed in parallel to the top MOSFET.

Power Good

The PGOOD1 pin is connected to an open-drain of an internal N-channel MOSFET. The MOSFET turns on and pulls the PGOOD1 pin low when the corresponding VFB1 pin voltage is not within $\pm 10\%$ of the 1.2V reference voltage. The PGOOD1 pin is also pulled low when the corresponding

RUN1 pin is low (shut down). When the VFB1 pin voltage is within the $\pm 10\%$ requirement, the MOSFET is turned off and the pin is allowed to be pulled up by an external resistor to a source of up to 6V.

Operation at Low SENSE Pin Common Voltage

The current comparator in the LTC3788-1 is powered directly from the SENSE⁺ pin. This enables the common mode voltage of SENSE⁺ and SENSE⁻ pins to operate at as low as 2.5V, which is below the UVLO threshold. Figure 1 shows a typical application when the controller's VBIAS is powered from V_{OUT} while V_{IN} supply can go as low as 2.5V. If the voltage on SENSE⁺ drops below 2.5V, the SS pin will be held low. When the SENSE voltage returns to the normal operating range, the SS pin will be released, initiating a new soft-start cycle.

BOOST Supply Refresh and Internal Charge Pump

Each top MOSFET driver is biased from the floating bootstrap capacitor C_B , which normally recharges during each cycle through an external diode when the bottom MOSFET turns on. There are two considerations to keep the BOOST supply at the required bias level. During start-up, if the bottom MOSFET is not turned on within 100 μ s after UVLO goes low, the bottom MOSFET will be forced to turn on for ~ 400 ns. This forced refresh generates enough BOOST-SW voltage to allow the top MOSFET ready to be fully enhanced instead of waiting for the initial few cycles to charge up. There is also an internal charge pump that keeps the required bias on BOOST. The charge pump always operates in both forced continuous mode and pulse-skipping mode. In Burst Mode operation, the charge pump is turned off during sleep and enabled when the chip wakes up. The internal charge pump can normally supply a charging current of 55 μ A.

APPLICATIONS INFORMATION

The Typical Application on the first page is a basic LTC3788-1 application circuit. LTC3788-1 can be configured to use either inductor DCR (DC resistance) sensing or a discrete sense resistor (R_{SENSE}) for current sensing. The choice between the two current sensing schemes is largely a design trade-off between cost, power consumption and accuracy. DCR sensing is becoming popular because it does not require current sensing resistors and is more power-efficient, especially in high current applications. However, current sensing resistors provide the most accurate current limits for the controller. Other external component selection is driven by the load requirement, and begins with the selection of R_{SENSE} (if R_{SENSE} is used) and inductor value. Next, the power MOSFETs are selected. Finally, input and output capacitors are selected.

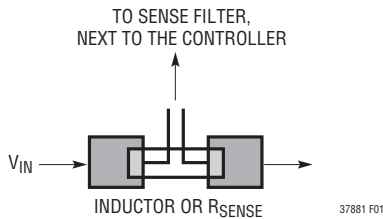

Figure 1. Sense Lines Placement with Inductor or Sense Resistor

SENSE+ and SENSE- Pins

The SENSE+ and SENSE- pins are the inputs to the current comparators. The common mode input voltage range of the current comparators is 2.5V to 38V. The current sense resistor is normally placed at the input of the boost controller in series with the inductor.

The SENSE+ pin also provides power to the current comparator. It draws ~200 μ A during normal operation. There is a small base current of less than 1 μ A that flows into the SENSE- pin. The high impedance SENSE- input to the current comparators allow accurate DCR sensing.

Filter components mutual to the sense lines should be placed close to the LTC3788-1, and the sense lines should run close together to a Kelvin connection underneath the current sense element (shown in Figure 1). Sensing current elsewhere can effectively add parasitic inductance and capacitance to the current sense element, degrading the information at the sense terminals and making the programmed current limit unpredictable. If DCR sensing is used (Figure 2b), sense resistor R1 should be placed close to the switching node, to prevent noise from coupling into sensitive small-signal nodes.

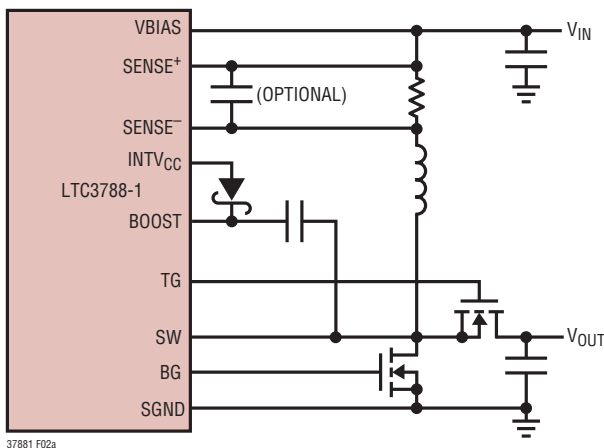

(2a) Using a Resistor to Sense Current

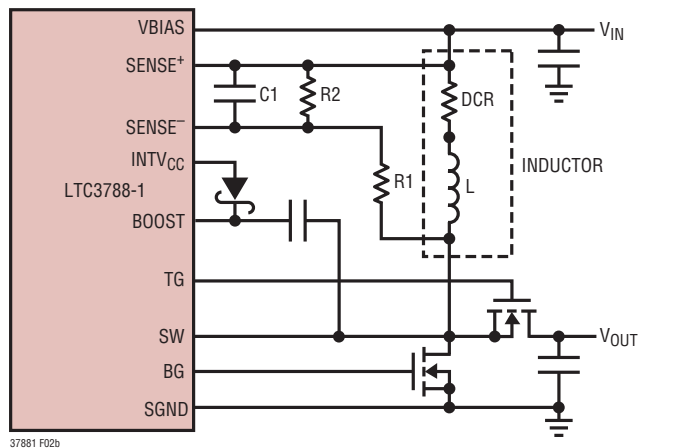

PLACE C1 NEAR SENSE PINS $(R1 \parallel R2) \cdot C1 = \frac{L}{DCR}$ $R_{SENSE(EQ)} = DCR \cdot \frac{R2}{R1 + R2}$

(2b) Using the Inductor DCR to Sense Current

Figure 2. Two Different Methods of Sensing Current

APPLICATIONS INFORMATION

Sense Resistor Current Sensing

A typical sensing circuit using a discrete resistor is shown in Figure 2a. R_{SENSE} is chosen based on the required output current.

The current comparator has a maximum threshold $V_{SENSE(MAX)}$. When the ILIM pin is grounded, floating or tied to $INTV_{CC}$, the maximum threshold is set to 50mV, 75mV or 100mV, respectively. The current comparator threshold sets the peak of the inductor current, yielding a maximum average output current, I_{MAX} , equal to the peak value less half the peak-to-peak ripple current, ΔI_L . To calculate the sense resistor value, use the equation:

$$R_{SENSE} = \frac{V_{SENSE(MAX)}}{I_{MAX} + \frac{\Delta I_L}{2}}$$

When using the controller in low V_{IN} and very high voltage output applications, the maximum output current level will be reduced due to the internal compensation required to meet stability criterion for boost regulators operating at greater than 50% duty factor. A curve is provided in the Typical Performance Characteristics section to estimate this reduction in peak output current level depending upon the operating duty factor.

Inductor DCR Sensing

For applications requiring the highest possible efficiency at high load currents, the LTC3788-1 is capable of sensing the voltage drop across the inductor DCR, as shown in Figure 2b. The DCR of the inductor can be less than 1m Ω for high current inductors. In a high current application requiring such an inductor, conduction loss through a sense resistor could reduce the efficiency by a few percent compared to DCR sensing.

If the external $R1||R2 \cdot C1$ time constant is chosen to be exactly equal to the L/DCR time constant, the voltage drop across the external capacitor is equal to the drop across the inductor DCR multiplied by $R2/(R1 + R2)$. $R2$ scales the voltage across the sense terminals for applications where the DCR is greater than the target sense resistor value. To properly dimension the external filter components, the DCR of the inductor must be known. It can be measured

using a good RLC meter, but the DCR tolerance is not always the same and varies with temperature. Consult the manufacturer's data sheets for detailed information.

Using the inductor ripple current value from the inductor value calculation section, the target sense resistor value is:

$$R_{SENSE(EQUIV)} = \frac{V_{SENSE(MAX)}}{I_{MAX} + \frac{\Delta I_L}{2}}$$

To ensure that the application will deliver full load current over the full operating temperature range, choose the minimum value for the maximum current sense threshold ($V_{SENSE(MAX)}$).

Next, determine the DCR of the inductor. Where provided, use the manufacturer's maximum value, usually given at 20°C. Increase this value to account for the temperature coefficient of resistance, which is approximately 0.4%/°C. A conservative value for the maximum inductor temperature ($T_{L(MAX)}$) is 100°C.

To scale the maximum inductor DCR to the desired sense resistor value, use the divider ratio:

$$R_D = \frac{R_{SENSE(EQUIV)}}{DCR_{MAX} \text{ at } T_{L(MAX)}}$$

$C1$ is usually selected to be in the range of 0.1 μ F to 0.47 μ F. This forces $R1||R2$ to around 2k, reducing error that might have been caused by the SENSE⁺ pin's $\pm 1\mu$ A current.

The equivalent resistance $R1||R2$ is scaled to the room temperature inductance and maximum DCR:

$$R1||R2 = \frac{L}{(DCR \text{ at } 20^\circ\text{C}) \cdot C1}$$

The sense resistor values are:

$$R1 = \frac{R1||R2}{R_D}; \quad R2 = \frac{R1 \cdot R_D}{1 - R_D}$$

The maximum power loss in $R1$ is related to duty cycle, and will occur in continuous mode at $V_{IN} = 1/2 V_{OUT}$:

$$P_{LOSS} R1 = \frac{(V_{OUT} - V_{IN}) \cdot V_{IN}}{R1}$$

APPLICATIONS INFORMATION

Ensure that R1 has a power rating higher than this value. If high efficiency is necessary at light loads, consider this power loss when deciding whether to use DCR sensing or sense resistors. Light load power loss can be modestly higher with a DCR network than with a sense resistor, due to the extra switching losses incurred through R1. However, DCR sensing eliminates a sense resistor, reduces conduction losses and provides higher efficiency at heavy loads. Peak efficiency is about the same with either method.

Inductor Value Calculation

The operating frequency and inductor selection are inter-related in that higher operating frequencies allow the use of smaller inductor and capacitor values. Why would anyone ever choose to operate at lower frequencies with larger components? The answer is efficiency. A higher frequency generally results in lower efficiency because of MOSFET gate charge and switching losses. In addition to this basic trade-off, the effect of inductor value on ripple current and low current operation must also be considered.

The inductor value has a direct effect on ripple current. The inductor ripple current ΔI_L decreases with higher inductance or frequency and increases with higher V_{IN} :

$$\Delta I_L = \frac{V_{IN}}{f \cdot L} \left(1 - \frac{V_{IN}}{V_{OUT}} \right)$$

Accepting larger values of ΔI_L allows the use of low inductances, but results in higher output voltage ripple and greater core losses. A reasonable starting point for setting ripple current is $\Delta I_L = 0.3(I_{MAX})$. The maximum ΔI_L occurs at $V_{IN} = 1/2 V_{OUT}$.

The inductor value also has secondary effects. The transition to Burst Mode operation begins when the average inductor current required results in a peak current below 10% of the current limit determined by R_{SENSE} . Lower inductor values (higher ΔI_L) will cause this to occur at lower load currents, which can cause a dip in efficiency in the upper range of low current operation. In Burst Mode operation, lower inductance values will cause the burst frequency to decrease.

Inductor Core Selection

Once the value for L is known, the type of inductor must be selected. High efficiency converters generally cannot afford the core loss found in low cost powdered iron cores, forcing the use of more expensive ferrite or molypermalloy cores. Actual core loss is independent of core size for a fixed inductor value, but it is very dependent on inductance selected. As inductance increases, core losses go down. Unfortunately, because increased inductance requires more turns of wire, copper losses will increase.

Ferrite core inductors have very low core loss and are preferred at high switching frequencies, so design goals can concentrate on copper loss and preventing saturation. Ferrite core material saturates “hard,” which means that inductance collapses abruptly when the peak design current is exceeded. This results in an abrupt increase in inductor ripple current and consequent output voltage ripple. Do not allow the core to saturate!

Power MOSFET Selection

Two external power MOSFETs must be selected for each controller in the LTC3788-1: one N-channel MOSFET for the bottom (main) switch, and one N-channel MOSFET for the top (synchronous) switch.

The peak-to-peak gate drive levels are set by the $INTV_{CC}$ voltage. This voltage is typically 5.2V during start-up (see $EXTV_{CC}$ pin connection). Consequently, logic-level threshold MOSFETs must be used in most applications. The only exception is if low input voltage is expected ($V_{IN} < 5V$); then, sub-logic level threshold MOSFETs ($V_{GS(TH)} < 3V$) should be used. Pay close attention to the BV_{DSS} specification for the MOSFETs as well; many of the logic level MOSFETs are limited to 30V or less.

Selection criteria for the power MOSFETs include the on-resistance $R_{DS(ON)}$, Miller capacitance C_{MILLER} , input voltage and maximum output current. Miller capacitance, C_{MILLER} , can be approximated from the gate charge curve usually provided on the MOSFET manufacturer’s data sheet. C_{MILLER} is equal to the increase in gate charge along the horizontal axis while the curve is approximately flat divided by the specified change in V_{DS} . This result is then multiplied by the ratio of the application applied V_{DS} to the gate charge curve specified V_{DS} . When the IC is

37881f

APPLICATIONS INFORMATION

operating in continuous mode, the duty cycles for the top and bottom MOSFETs are given by:

$$\text{Main Switch Duty Cycle} = \frac{V_{\text{OUT}} - V_{\text{IN}}}{V_{\text{OUT}}}$$

$$\text{Synchronous Switch Duty Cycle} = \frac{V_{\text{IN}}}{V_{\text{OUT}}}$$

The MOSFET power dissipations at maximum output current are given by:

$$P_{\text{MAIN}} = \frac{(V_{\text{OUT}} - V_{\text{IN}})V_{\text{OUT}}}{V_{\text{IN}}^2} \cdot I_{\text{OUT(MAX)}}^2 \cdot (1 + \delta) \\ \cdot R_{\text{DS(ON)}} + k \cdot V_{\text{OUT}}^3 \cdot \frac{I_{\text{OUT(MAX)}}}{V_{\text{IN}}} \cdot R_{\text{DR}} \\ \cdot C_{\text{MILLER}} \cdot f$$

$$P_{\text{SYNC}} = \frac{V_{\text{IN}}}{V_{\text{OUT}}} \cdot I_{\text{OUT(MAX)}}^2 \cdot (1 + \delta) \cdot R_{\text{DS(ON)}}$$

where δ is the temperature dependency of $R_{\text{DS(ON)}}$ and R_{DR} (approximately 1Ω) is the effective driver resistance at the MOSFET's Miller threshold voltage. The constant k , which accounts for the loss caused by reverse recovery current, is inversely proportional to the gate drive current and has an empirical value of 1.7.

Both MOSFETs have I^2R losses while the bottom N-channel equation includes an additional term for transition losses, which are highest at low input voltages. For high V_{IN} the high current efficiency generally improves with larger MOSFETs, while for low V_{IN} the transition losses rapidly increase to the point that the use of a higher $R_{\text{DS(ON)}}$ device with lower C_{MILLER} actually provides higher efficiency. The synchronous MOSFET losses are greatest at high input voltage when the bottom switch duty factor is low or during overvoltage when the synchronous switch is on close to 100% of the period.

The term $(1 + \delta)$ is generally given for a MOSFET in the form of a normalized $R_{\text{DS(ON)}}$ vs Temperature curve, but $\delta = 0.005/^\circ\text{C}$ can be used as an approximation for low voltage MOSFETs.

C_{IN} and C_{OUT} Selection

The input ripple current in a boost converter is relatively low (compared with the output ripple current), because this current is continuous. The input capacitor C_{IN} voltage rating should comfortably exceed the maximum input voltage. Although ceramic capacitors can be relatively tolerant of overvoltage conditions, aluminum electrolytic capacitors are not. Be sure to characterize the input voltage for any possible overvoltage transients that could apply excess stress to the input capacitors.

The value of the C_{IN} is a function of the source impedance, and in general, the higher the source impedance, the higher the required input capacitance. The required amount of input capacitance is also greatly affected by the duty cycle. High output current applications that also experience high duty cycles can place great demands on the input supply, both in terms of DC current and ripple current.

In a boost converter, the output has a discontinuous current, so C_{OUT} must be capable of reducing the output voltage ripple. The effects of ESR (equivalent series resistance) and the bulk capacitance must be considered when choosing the right capacitor for a given output ripple voltage. The steady ripple voltage due to charging and discharging the bulk capacitance is given by:

$$V_{\text{RIPPLE}} = \frac{I_{\text{OUT(MAX)}} \cdot (V_{\text{OUT}} - V_{\text{IN(MIN)}})}{C_{\text{OUT}} \cdot V_{\text{OUT}} \cdot f} V$$

where C_{OUT} is the output filter capacitor.

The steady ripple due to the voltage drop across the ESR is given by:

$$\Delta V_{\text{ESR}} = I_{\text{L(MAX)}} \cdot \text{ESR}$$

The LTC3788-1 can also be configured as a 2-phase single output converter where the outputs of the two channels are connected together and both channels have the same duty cycle. With 2-phase operation, the two channels of the dual switching regulator are operated 180 degrees out-of-phase. This effectively interleaves the output current pulses, greatly reducing the output capacitor ripple current. As a result, the ESR requirement of the capacitor can be relaxed. Because the ripple current in the output capacitor is a square wave, the ripple current requirements for the output capacitor depend on the duty cycle, the number

37881f

APPLICATIONS INFORMATION

of phases and the maximum output current. Figure 3 illustrates the normalized output capacitor ripple current as a function of duty cycle in a 2-phase configuration. To choose a ripple current rating for the output capacitor, first establish the duty cycle range based on the output voltage and range of input voltage. Referring to Figure 3, choose the worst-case high normalized ripple current as a percentage of the maximum load current.

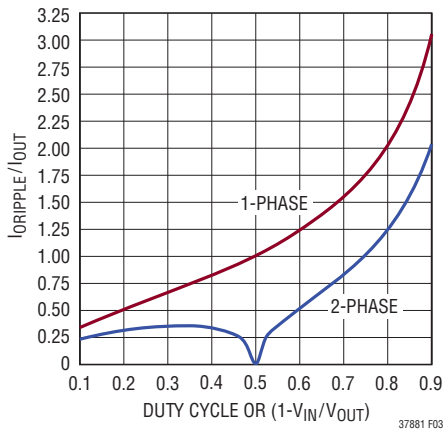

Figure 3. Normalized Output Capacitor Ripple Current (RMS) for a Boost Converter

Multiple capacitors placed in parallel may be needed to meet the ESR and RMS current handling requirements. Dry tantalum, special polymer, aluminum electrolytic and ceramic capacitors are all available in surface mount packages. Ceramic capacitors have excellent low ESR characteristics but can have a high voltage coefficient. Capacitors are now available with low ESR and high ripple current ratings (i.e., OS-CON and POSCAP).

Setting Output Voltage

The LTC3788-1 output voltages are each set by an external feedback resistor divider carefully placed across the output, as shown in Figure 4. The regulated output voltage is determined by:

$$V_{OUT} = 1.2V \left(1 + \frac{R_B}{R_A} \right)$$

Great care should be taken to route the V_{FB} line away from noise sources, such as the inductor or the SW line.

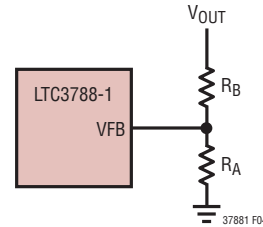

Figure 4. Setting Output Voltage

Soft-Start (SS Pins)

The start-up of each V_{OUT} is controlled by the voltage on the respective SS pins. When the voltage on the SS pin is less than the internal 1.2V reference, the LTC3788-1 regulates the VFB pin voltage to the voltage on the SS pin instead of 1.2V.

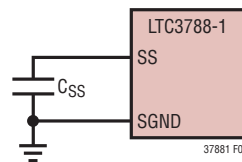

Figure 5. Using the SS Pin to Program Soft-Start

Soft-start is enabled by simply connecting a capacitor from the SS pin to ground, as shown in Figure 5. An internal $10\mu A$ current source charges the capacitor, providing a linear ramping voltage at the SS pin. The LTC3788-1 will regulate the VFB pin (and hence, V_{OUT}) according to the voltage on the SS pin, allowing V_{OUT} to rise smoothly from V_{IN} to its final regulated value. The total soft-start time will be approximately:

$$t_{SS} = C_{SS} \cdot \frac{1.2V}{10\mu A}$$

APPLICATIONS INFORMATION

INTV_{CC} Regulators

The LTC3788-1 features two separate internal P-channel low dropout linear regulators (LDO) that supply power at the INTV_{CC} pin from either the VBIAS supply pin or the EXTV_{CC} pin depending on the connection of the EXTV_{CC} pin. INTV_{CC} powers the gate drivers and much of the LTC3788-1's internal circuitry. The VBIAS LDO and the EXTV_{CC} LDO regulate INTV_{CC} to 5.4V. Each of these can supply a peak current of 50mA and must be bypassed to ground with a minimum of 4.7μF ceramic capacitor. Good bypassing is needed to supply the high transient currents required by the MOSFET gate drivers and to prevent interaction between the channels.

High input voltage applications in which large MOSFETs are being driven at high frequencies may cause the maximum junction temperature rating for the LTC3788-1 to be exceeded. The INTV_{CC} current, which is dominated by the gate charge current, may be supplied by either the VBIAS LDO or the EXTV_{CC} LDO. When the voltage on the EXTV_{CC} pin is less than 4.8V, the VBIAS LDO is enabled. In this case, power dissipation for the IC is highest and is equal to $V_{IN} \cdot I_{INTVCC}$. The gate charge current is dependent on operating frequency, as discussed in the Efficiency Considerations section. The junction temperature can be estimated by using the equations given in Note 3 of the Electrical Characteristics. For example, the LTC3788-1 INTV_{CC} current is limited to less than 15mA from a 40V supply when not using the EXTV_{CC} supply:

$$T_J = 70^\circ\text{C} + (15\text{mA})(40\text{V})(90^\circ\text{C}/\text{W}) = 125^\circ\text{C}$$

To prevent the maximum junction temperature from being exceeded, the input supply current must be checked while operating in continuous conduction mode (PLLIN/MODE = INTV_{CC}) at maximum V_{IN} .

When the voltage applied to EXTV_{CC} rises above 4.7V, the V_{IN} LDO is turned off and the EXTV_{CC} LDO is enabled. The EXTV_{CC} LDO remains on as long as the voltage applied to EXTV_{CC} remains above 4.55V. The EXTV_{CC} LDO attempts to regulate the INTV_{CC} voltage to 5.4V, so while EXTV_{CC} is less than 5.4V, the LDO is in dropout and the INTV_{CC} voltage is approximately equal to EXTV_{CC}. When EXTV_{CC} is greater than 5.4V, up to an absolute maximum of 6V, INTV_{CC} is regulated to 5.4V.

The following list summarizes possible connections for EXTV_{CC}:

EXTV_{CC} Left Open (or Grounded). This will cause INTV_{CC} to be powered from the internal 5.4V regulator resulting in an efficiency penalty at high input voltages.

EXTV_{CC} Connected to an External Supply. If an external supply is available in the 5.4V to 6V range, it may be used to power EXTV_{CC} providing it is compatible with the MOSFET gate drive requirements. Ensure that $EXTV_{CC} < V_{BIAS}$.

Topside MOSFET Driver Supply (C_B, D_B)

External bootstrap capacitors C_B connected to the BOOST pins supply the gate drive voltages for the topside MOSFETs. Capacitor C_B in the Block Diagram is charged through external diode D_B from INTV_{CC} when the SW pin is low. When one of the topside MOSFETs is to be turned on, the driver places the C_B voltage across the gate-source of the desired MOSFET. This enhances the MOSFET and turns on the topside switch. The switch node voltage, SW, rises to V_{IN} and the BOOST pin follows. With the topside MOSFET on, the boost voltage is above the input supply: $V_{BOOST} = V_{IN} + V_{INTVCC}$. The value of the boost capacitor C_B needs to be 100 times that of the total input capacitance of the topside MOSFET(s). The reverse breakdown of the external Schottky diode must be greater than $V_{IN(MAX)}$.

Fault Conditions: Overtemperature Protection

At higher temperatures, or in cases where the internal power dissipation causes excessive self-heating on chip (such as an INTV_{CC} short to ground), the overtemperature shutdown circuitry will shut down the LTC3788-1. When the junction temperature exceeds approximately 170°C, the overtemperature circuitry disables the INTV_{CC} LDO, causing the INTV_{CC} supply to collapse and effectively shut down the entire LTC3788-1 chip. Once the junction temperature drops back to approximately 155°C, the INTV_{CC} LDO turns back on. Long term overstress ($T_J > 125^\circ\text{C}$) should be avoided as it can degrade the performance or shorten the life of the part.

APPLICATIONS INFORMATION

Phase-Locked Loop and Frequency Synchronization

The LTC3788-1 has an internal phase-locked loop (PLL) comprised of a phase frequency detector, a low pass filter and a voltage-controlled oscillator (VCO). This allows the turn-on of the top MOSFET of controller 1 to be locked to the rising edge of an external clock signal applied to the PLLIN/MODE pin. The turn-on of controller 2's top MOSFET is thus 180 degrees out-of-phase with the external clock. The phase detector is an edge-sensitive digital type that provides zero degrees phase shift between the external and internal oscillators. This type of phase detector does not exhibit false lock to harmonics of the external clock.

If the external clock frequency is greater than the internal oscillator's frequency, f_{OSC} , then current is sourced continuously from the phase detector output, pulling up the VCO input. When the external clock frequency is less than f_{OSC} , current is sunk continuously, pulling down the VCO input. If the external and internal frequencies are the same but exhibit a phase difference, the current sources turn on for an amount of time corresponding to the phase difference. The voltage at the VCO input is adjusted until the phase and frequency of the internal and external oscillators are identical. At the stable operating point, the phase detector output is high impedance and the internal filter capacitor, C_{LP} , holds the voltage at the VCO input.

Typically, the external clock (on PLLIN/MODE pin) input high threshold is 1.6V, while the input low threshold is 1.2V.

Note that the LTC3788-1 can only be synchronized to an external clock whose frequency is within range of the LTC3788-1's internal VCO, which is nominally 55kHz to 1MHz. This is guaranteed to be between 75kHz and 850kHz.

Rapid phase locking can be achieved by using the FREQ pin to set a free-running frequency near the desired synchronization frequency. The VCO's input voltage is prebiased at a frequency corresponding to the frequency set by the FREQ pin. Once prebiased, the PLL only needs to adjust the frequency slightly to achieve phase lock and synchronization. Although it is not required that the free-running frequency be near external clock frequency, doing so will prevent the operating frequency from passing through a large range of frequencies as the PLL locks.

Table 1 summarizes the different states in which the FREQ pin can be used.

Table 1.

FREQ PIN	PLLIN/MODE PIN	FREQUENCY
0V	DC Voltage	350kHz
INTV _{CC}	DC Voltage	535kHz
Resistor	DC Voltage	50kHz to 900kHz
Any of the Above	External Clock	Phase Locked to External Clock

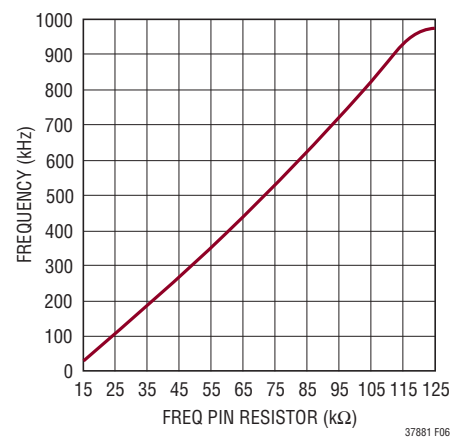

Figure 6. Relationship Between Oscillator Frequency and Resistor Value at the FREQ Pin

Minimum On-Time Considerations

Minimum on-time, $t_{ON(MIN)}$, is the smallest time duration that the LTC3788-1 is capable of turning on the bottom MOSFET. It is determined by internal timing delays and the gate charge required to turn on the top MOSFET. Low duty cycle applications may approach this minimum on-time limit.

In forced continuous mode, if the duty cycle falls below what can be accommodated by the minimum on-time, the controller will begin to skip cycles but the output will continue to be regulated. More cycles will be skipped when V_{IN} increases. Once V_{IN} rises above V_{OUT} , the loop works to keep the top MOSFET on continuously. The minimum on-time for the LTC3788-1 is approximately 110ns.

APPLICATIONS INFORMATION

Efficiency Considerations

The percent efficiency of a switching regulator is equal to the output power divided by the input power times 100%. It is often useful to analyze individual losses to determine what is limiting the efficiency and which change would produce the greatest improvement. Percent efficiency can be expressed as:

$$\% \text{Efficiency} = 100\% - (L1 + L2 + L3 + \dots)$$

where L1, L2, etc., are the individual losses as a percentage of input power.

Although all dissipative elements in the circuit produce losses, four main sources usually account for most of the losses in LTC3788-1 circuits: 1) IC V_{IN} current, 2) INTV_{CC} regulator current, 3) I^2R losses, 4) Bottom MOSFET transition losses.

1. The V_{IN} current is the DC supply current given in the Electrical Characteristics table, which excludes MOSFET driver and control currents. V_{IN} current typically results in a small (<0.1%) loss.
2. INTV_{CC} current is the sum of the MOSFET driver and control currents. The MOSFET driver current results from switching the gate capacitance of the power MOSFETs. Each time a MOSFET gate is switched from low to high to low again, a packet of charge, dQ , moves from INTV_{CC} to ground. The resulting dQ/dt is a current out of INTV_{CC} that is typically much larger than the control circuit current. In continuous mode, $I_{GATECHG} = f(Q_T + Q_B)$, where Q_T and Q_B are the gate charges of the topside and bottom side MOSFETs.
3. DC I^2R losses. These arise from the resistances of the MOSFETs, sensing resistor, inductor and PC board traces and cause the efficiency to drop at high output currents.
4. Transition losses apply only to the bottom MOSFET(s), and become significant only when operating at low input voltages (typically 15V or greater). Transition losses can be estimated from:

$$\text{Transition Loss} = (1.7) \frac{V_{OUT}^3}{V_{IN}} I_{O(MAX)} \cdot C_{RSS} f$$

Other hidden losses, such as copper trace and internal battery resistances, can account for an additional 5% to

10% efficiency degradation in portable systems. It is very important to include these system-level losses during the design phase.

Checking Transient Response

The regulator loop response can be checked by looking at the load current transient response. Switching regulators take several cycles to respond to a step in DC (resistive) load current. When a load step occurs, V_{OUT} shifts by an amount equal to ΔI_{LOAD} (ESR), where ESR is the effective series resistance of C_{OUT} . ΔI_{LOAD} also begins to charge or discharge C_{OUT} generating the feedback error signal that forces the regulator to adapt to the current change and return V_{OUT} to its steady-state value. During this recovery time V_{OUT} can be monitored for excessive overshoot or ringing, which would indicate a stability problem. OPTI-LOOP compensation allows the transient response to be optimized over a wide range of output capacitance and ESR values. *The availability of the ITH pin not only allows optimization of control loop behavior, but it also provides a DC coupled and AC filtered closed loop response test point. The DC step, rise time and settling at this test point truly reflects the closed loop response.* Assuming a predominantly second order system, phase margin and/or damping factor can be estimated using the percentage of overshoot seen at this pin. The bandwidth can also be estimated by examining the rise time at the pin. The I_{TH} external components shown in Figure 9 circuit will provide an adequate starting point for most applications.

The I_{TH} series RC-CC filter sets the dominant pole-zero loop compensation. The values can be modified slightly (from 0.5 to 2 times their suggested values) to optimize transient response once the final PC layout is complete and the particular output capacitor type and value have been determined. The output capacitors must be selected because the various types and values determine the loop gain and phase. An output current pulse of 20% to 80% of full-load current having a rise time of 1 μ s to 10 μ s will produce output voltage and ITH pin waveforms that will give a sense of the overall loop stability without breaking the feedback loop.

Placing a power MOSFET and load resistor directly across the output capacitor and driving the gate with an appropriate signal generator is a practical way to produce

37881f

APPLICATIONS INFORMATION

a realistic load step condition. The initial output voltage step resulting from the step change in output current may not be within the bandwidth of the feedback loop, so this signal cannot be used to determine phase margin. This is why it is better to look at the ITH pin signal which is in the feedback loop and is the filtered and compensated control loop response.

The gain of the loop will be increased by increasing R_C and the bandwidth of the loop will be increased by decreasing C_C . If R_C is increased by the same factor that C_C is decreased, the zero frequency will be kept the same, thereby keeping the phase shift the same in the most critical frequency range of the feedback loop. The output voltage settling behavior is related to the stability of the closed-loop system and will demonstrate the actual overall supply performance.

A second, more severe transient is caused by switching in loads with large ($>1\mu\text{F}$) supply bypass capacitors. The discharged bypass capacitors are effectively put in parallel with C_{OUT} , causing a rapid drop in V_{OUT} . No regulator can alter its delivery of current quickly enough to prevent this sudden step change in output voltage if the load switch resistance is low and it is driven quickly. If the ratio of C_{LOAD} to C_{OUT} is greater than 1:50, the switch rise time should be controlled so that the load rise time is limited to approximately $25 \cdot C_{LOAD}$. Thus, a $10\mu\text{F}$ capacitor would require a $250\mu\text{s}$ rise time, limiting the charging current to about 200mA.

Design Example

As a design example for one channel, assume $V_{IN} = 12\text{V}$ (nominal), $V_{IN} = 22\text{V}$ (max), $V_{OUT} = 24\text{V}$, $I_{MAX} = 4\text{A}$, $V_{SENSE(MAX)} = 75\text{mV}$, and $f = 350\text{kHz}$.

The inductance value is chosen first based on a 30% ripple current assumption. The highest value of ripple current occurs at the maximum input voltage. Tie the PLLLPF pin to GND, generating 350kHz operation. The minimum inductance for 30% ripple current is:

$$\Delta I_L = \frac{V_{IN}}{f \cdot L} \left(1 - \frac{V_{IN}}{V_{OUT}} \right)$$

A $6.8\mu\text{H}$ inductor will produce a 30% ripple current. The peak inductor current will be the maximum DC value plus one half the ripple current, or 9.25A.

The R_{SENSE} resistor value can be calculated by using the maximum current sense voltage specification with some accommodation for tolerances:

$$R_{SENSE} \leq \frac{75\text{mV}}{9.25\text{A}} = 0.008\Omega$$

Choosing 1% resistors: $R_A = 5\text{k}$ and $R_B = 95.3\text{k}$ yields an output voltage of 24.072V.

The power dissipation on the top side MOSFET can be easily estimated. Choosing a Vishay Si7848BDP MOSFET results in: $R_{DS(ON)} = 0.012\Omega$, $C_{MILLER} = 150\text{pF}$. At maximum input voltage with T (estimated) = 50°C :

$$P_{MAIN} = \frac{(24\text{V} - 12\text{V}) 24\text{V}}{(12\text{V})^2} \cdot (4\text{A})^2 \\ \cdot [1 + (0.005)(50^\circ\text{C} - 25^\circ\text{C})] \cdot 0.008\Omega \\ + (1.7)(24\text{V})^3 \frac{4\text{A}}{12\text{V}} (150\text{pF})(350\text{kHz}) = 0.7\text{W}$$

C_{OUT} is chosen to filter the square current in the output. The maximum output current peak is:

$$I_{OUT(PEAK)} = \frac{24}{12} \cdot 4 \left(1 + \frac{31\%}{2} \right) = 9.3\text{A}$$

A low ESR ($5\text{m}\Omega$) capacitor is suggested. This capacitor will limit output voltage ripple to 46.5mV (assuming ESR dominate ripple).

PC Board Layout Checklist

When laying out the printed circuit board, the following checklist should be used to ensure proper operation of the IC. These items are also illustrated graphically in the layout diagram of Figure 7. Figure 8 illustrates the current waveforms present in the various branches of the 2-phase synchronous regulators operating in the continuous mode. Check the following in your layout:

1. Put the bottom N-channel MOSFETs MBOT1 and MBOT2 and the top N-channel MOSFETs MTOP1 and MTOP2 in one compact area with C_{OUT} .

APPLICATIONS INFORMATION

- Are the signal and power grounds kept separate? The combined IC signal ground pin and the ground return of C_{INTVCC} must return to the combined C_{OUT} (-) terminals. The path formed by the bottom N-channel MOSFET and the C_{IN} capacitor should have short leads and PC trace lengths. The output capacitor (-) terminals should be connected as close as possible to the (-) terminals of the input capacitor by placing the capacitors next to each other.
- Do the LTC3788-1 VFB pins' resistive dividers connect to the (+) terminals of C_{OUT} ? The resistive divider must be connected between the (+) terminal of C_{OUT} and signal ground and placed close to the VFB pin. The feedback resistor connections should not be along the high current input feeds from the input capacitor(s).
- Are the $SENSE^-$ and $SENSE^+$ leads routed together with minimum PC trace spacing? The filter capacitor between $SENSE^+$ and $SENSE^-$ should be as close as possible to the IC. Ensure accurate current sensing with Kelvin connections at the sense resistor.
- Is the $INTV_{CC}$ decoupling capacitor connected close to the IC, between the $INTV_{CC}$ and the power ground pins? This capacitor carries the MOSFET drivers' current peaks. An additional $1\mu F$ ceramic capacitor placed immediately next to the $INTV_{CC}$ and PGND pins can help improve noise performance substantially.
- Keep the switching nodes (SW1, SW2), top gate nodes (TG1, TG2) and boost nodes (BOOST1, BOOST2) away from sensitive small-signal nodes, especially from the opposites channel's voltage and current sensing feedback pins. All of these nodes have very large and fast moving signals and, therefore, should be kept on the output side of the LTC3788-1 and occupy a minimal PC trace area.
- Use a modified "star ground" technique: a low impedance, large copper area central grounding point on the same side of the PC board as the input and output capacitors with tie-ins for the bottom of the $INTV_{CC}$ decoupling capacitor, the bottom of the voltage feedback resistive divider and the SGND pin of the IC.

PC Board Layout Debugging

Start with one controller on at a time. It is helpful to use a DC-50MHz current probe to monitor the current in the inductor while testing the circuit. Monitor the output switching node (SW pin) to synchronize the oscilloscope to the internal oscillator and probe the actual output voltage. Check for proper performance over the operating voltage and current range expected in the application. The frequency of operation should be maintained over the input voltage range down to dropout and until the output load drops below the low current operation threshold— typically 10% of the maximum designed current level in Burst Mode operation.

The duty cycle percentage should be maintained from cycle to cycle in a well designed, low noise PCB implementation. Variation in the duty cycle at a subharmonic rate can suggest noise pickup at the current or voltage sensing inputs or inadequate loop compensation. Overcompensation of the loop can be used to tame a poor PC layout if regulator bandwidth optimization is not required. Only after each controller is checked for its individual performance should both controllers be turned on at the same time. A particularly difficult region of operation is when one controller channel is nearing its current comparator trip point while the other channel is turning on its bottom MOSFET. This occurs around the 50% duty cycle on either channel due to the phasing of the internal clocks and may cause minor duty cycle jitter.

Reduce V_{IN} from its nominal level to verify operation with high duty cycle. Check the operation of the undervoltage lockout circuit by further lowering V_{IN} while monitoring the outputs to verify operation.

Investigate whether any problems exist only at higher output currents or only at higher input voltages. If problems coincide with high input voltages and low output currents, look for capacitive coupling between the BOOST, SW, TG, and possibly BG connections and the sensitive voltage and current pins. The capacitor placed across the current sensing pins needs to be placed immediately adjacent to the pins of the IC. This capacitor helps to minimize the effects of differential noise injection due to high frequency capacitive coupling. If problems are encountered with high current output loading at lower input voltages, look

APPLICATIONS INFORMATION

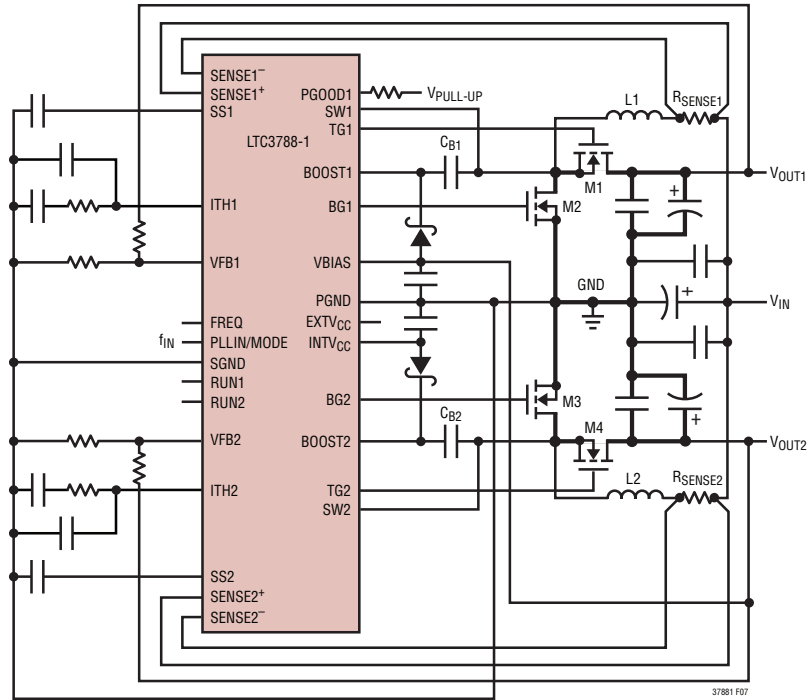

Figure 7. Recommended Printed Circuit Layout Diagram

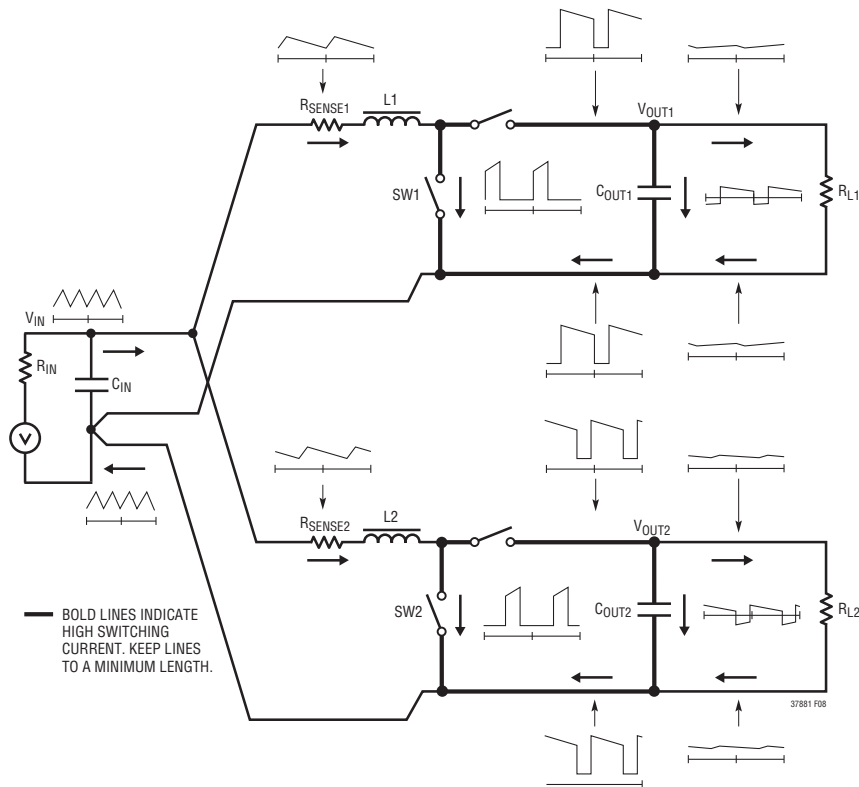

Figure 8. Branch Current Waveforms

APPLICATIONS INFORMATION

for inductive coupling between C_{IN} , Schottky and the top MOSFET components to the sensitive current and voltage sensing traces. In addition, investigate common ground path voltage pickup between these components and the SGND pin of the IC.

An embarrassing problem, which can be missed in an otherwise properly working switching regulator results when the current sensing leads are hooked up backwards.

The output voltage under this improper hook-up will still be maintained, but the advantages of current mode control will not be realized. Compensation of the voltage loop will be much more sensitive to component selection. This behavior can be investigated by temporarily shorting out the current sensing resistor—don't worry, the regulator will still maintain control of the output voltage.

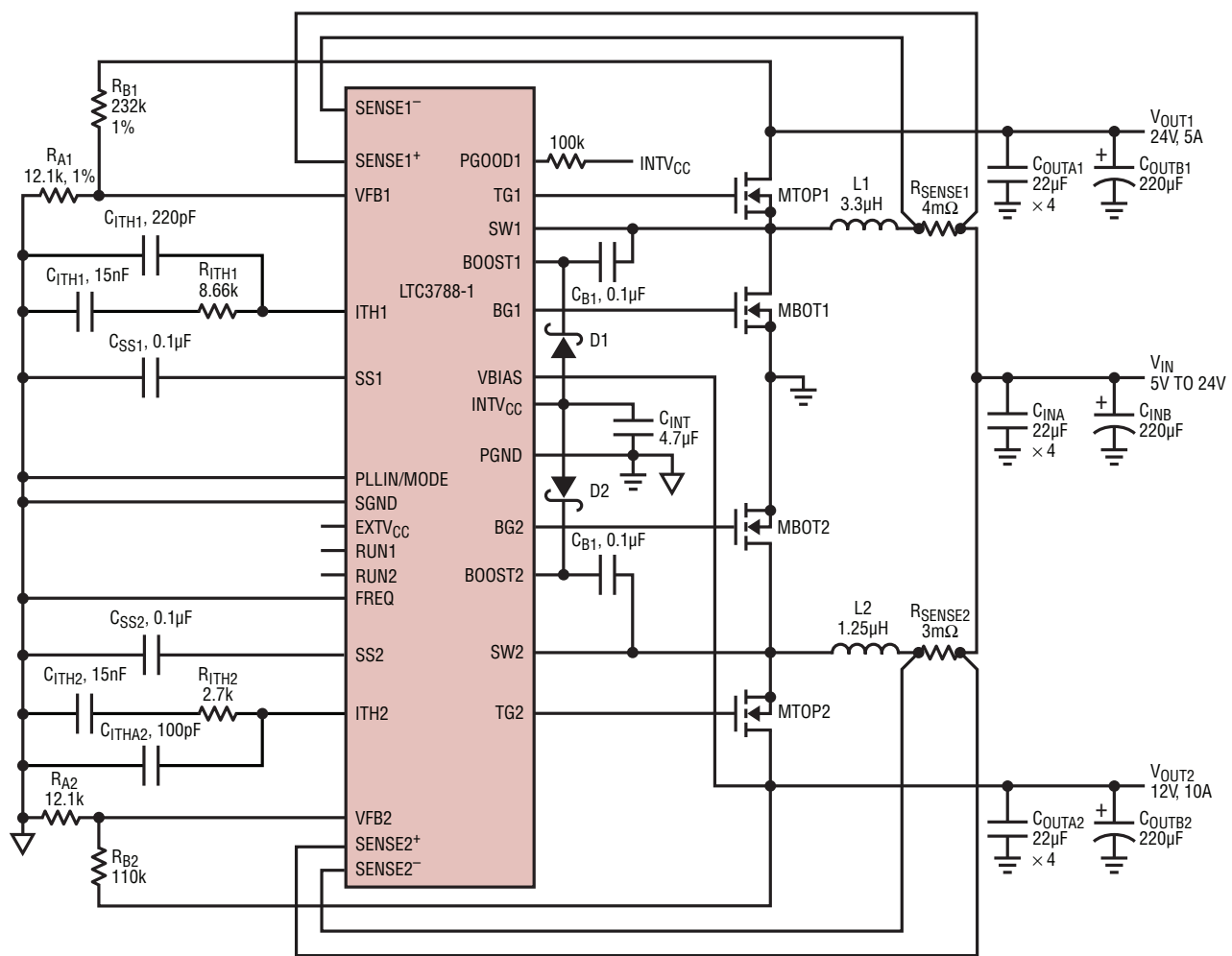

C_{INA} , C_{OUTA1} , C_{OUTA2} : SANYO, 50CE220AX
 C_{INB} , C_{OUTB1} , C_{OUTB2} : TDK C4532X5R1E226M
 L1: PULSE PA1494.362NL
 L2: PULSE PA1294.132NL
 MBOT1, MBOT2, MTOP1, MTOP2: RENESAS HAT2169H

Figure 9. High Efficiency Dual 12V/24V Boost Converter

TYPICAL APPLICATIONS

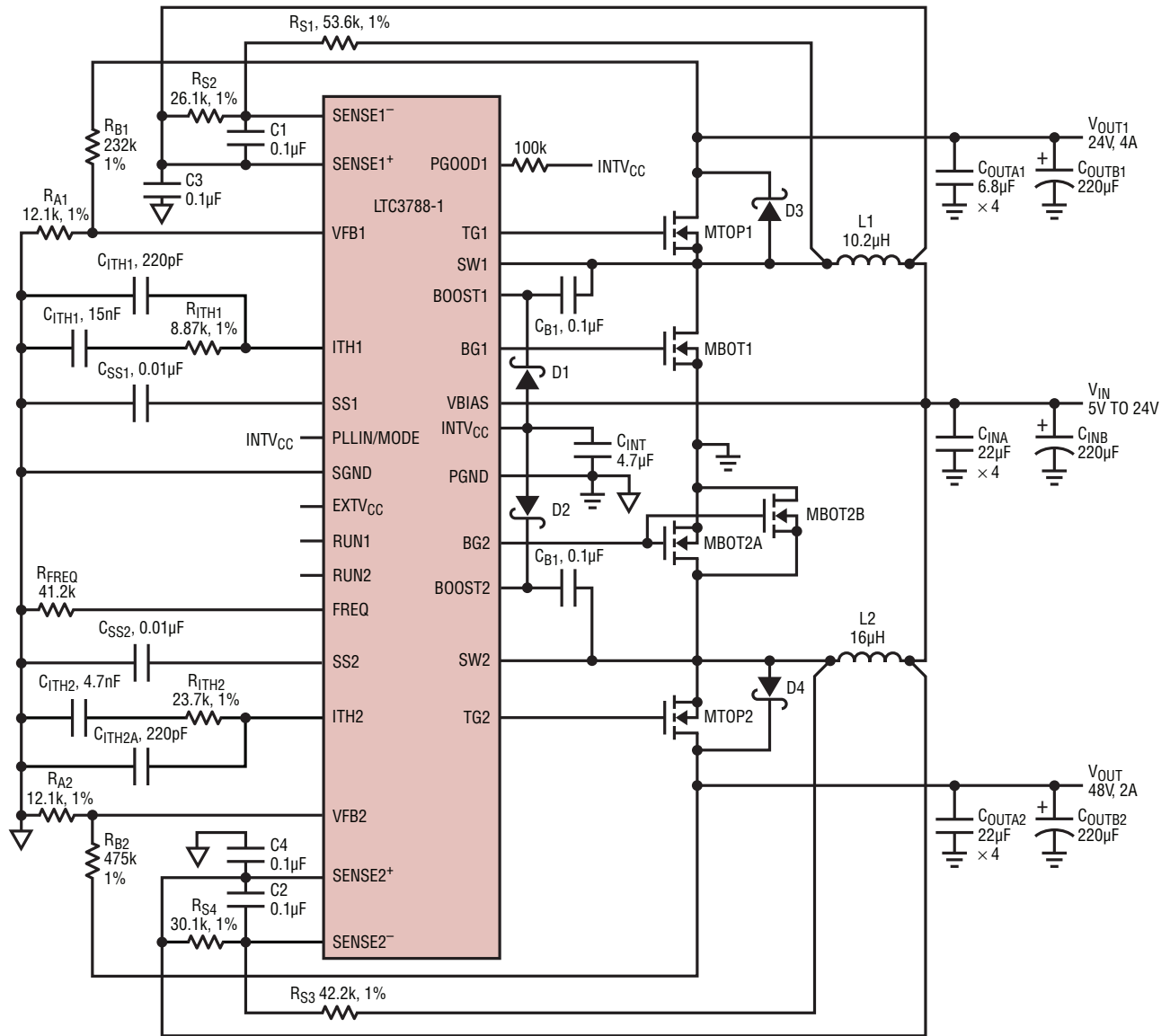

- C_{OUTA1}: C4532x7R1H685K
- C_{OUTB1}: SANYO 63CE220KX
- C_{INA}, C_{OUTA2}: TDK C4532X5R1E226M
- C_{INB}, C_{OUTB2}: SANYO 50CE220AX
- L1: PULSE PA2050.103NL
- L2: PULSE PA2050.163NL
- MBOT1, MTOP1: RENESAS RJK0305
- MBOT2A, MBOT2B, MTOP2: RENESAS RJK0652
- D3: DIODES INC B340B
- D4: DIODES INC B360A

Figure 10. High Efficiency Dual 24V/48V Boost Converter with Inductor DCR Current Sensing

PACKAGE DESCRIPTION

GN Package 28-Lead Plastic SSOP (Narrow .150 Inch) (Reference LTC DWG # 05-08-1641)

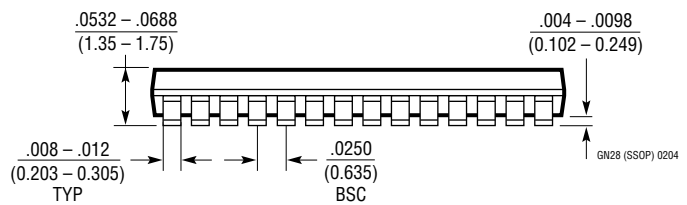
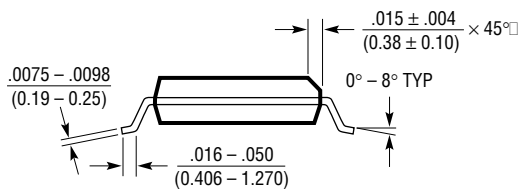
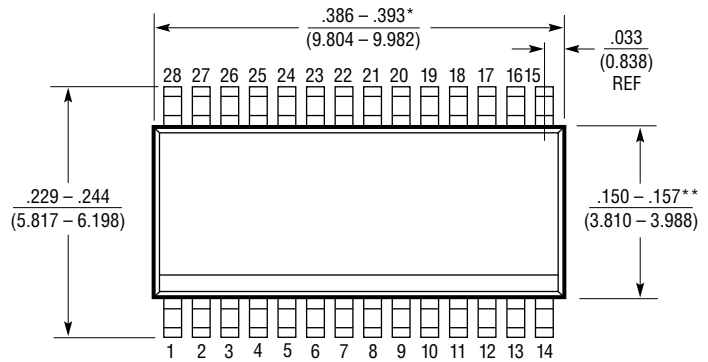
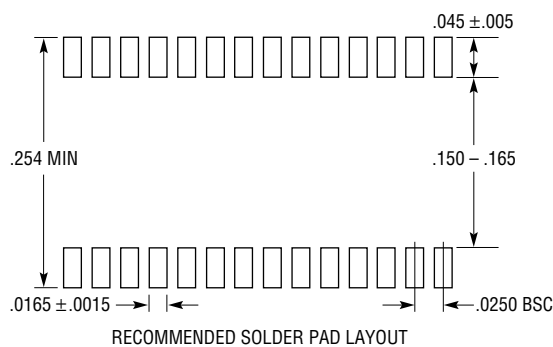

- NOTE:
1. CONTROLLING DIMENSION: INCHES
 2. DIMENSIONS ARE IN $\frac{\text{INCHES}}{\text{MILLIMETERS}}$
 3. DRAWING NOT TO SCALE
- *DIMENSION DOES NOT INCLUDE MOLD FLASH. MOLD FLASH SHALL NOT EXCEED 0.006" (0.152mm) PER SIDE
- **DIMENSION DOES NOT INCLUDE INTERLEAD FLASH. INTERLEAD FLASH SHALL NOT EXCEED 0.010" (0.254mm) PER SIDE

RELATED PARTS

PART NUMBER	DESCRIPTION	COMMENTS
LTC3788	Multiphase, Dual Output Synchronous Step-Up Controller	$4.5V \leq V_{IN} \leq 38V$, V_{OUT} Up to 60V, 50kHz to 900kHz, 5mm × 5mm QFN-32 Package
LTC3862/LTC3862-1	Multiphase Current Mode Step-Up DC/DC Controller	$4V \leq V_{IN} \leq 36V$, 5V or 10V Gate Drive, 75kHz to 500kHz
LTC3813	100V Maximum V_{OUT} Current Mode Synchronous Step-Up DC/DC Controller	No R_{SENSE} , Large 1 Ω Gate Driver, Adjustable Off-Time, SSOP-28 Package
LTC3814-5	60V Maximum V_{OUT} Current Mode Synchronous Step-Up DC/DC Controller	No R_{SENSE} , Large 1 Ω Gate Driver, Adjustable Off-Time, TSSOP-16 Package
LTC1871/LTC1871-1/ LTC1871-7	Wide Input Range, No R_{SENSE} Low Quiescent Current Flyback, Boost and SEPIC Controller	Adjustable Switching Frequency, $2.5V \leq V_{IN} \leq 36V$, Burst Mode Operation at Light Load, MSOP-10 Package
LT3757	Boost, Flyback, SEPIC and Inverting Controller	$2.9V \leq V_{IN} \leq 40V$, 100kHz to 1MHz Programmable Operation Frequency, 3mm × 3mm DFN-10 and MSOP-10E Packages
LT3758	Boost, Flyback, SEPIC and Inverting Controller	$5.5V \leq V_{IN} \leq 100V$, 100kHz to 1MHz Programmable Operation Frequency, 3mm × 3mm DFN-10 and MSOP-10E Packages
LT3782A	2-Phase Step-Up DC/DC Controller	$6V \leq V_{IN} \leq 40V$, Optional Synchronous Operation
LT3580	Boost/Inverting DC/DC Converter with 2A Switch, Soft-Start and Synchronization	$2.5V \leq V_{IN} \leq 32V$, 200kHz to 2.5MHz, 3mm × 3mm DFN-8 and MSOP-8E Packages
LTC3872	No R_{SENSE} Current Mode Boost DC/DC Controller	550kHz Fixed Frequency, $2.75V \leq V_{IN} \leq 9.8V$, ThinSOT Package
LTC3857/LTC3857-1	Low I_Q , Dual, 2-Phase Synchronous Step-Down DC/DC Controller	$4V \leq V_{IN} \leq 38V$, $0.8V \leq V_{OUT} \leq 24V$, 50 μ A I_Q
LTC3780	High Efficiency Synchronous 4-Switch Buck-Boost DC/DC Controller	$4V \leq V_{IN} \leq 36V$, $0.8V \leq V_{OUT} \leq 30V$, SSOP-24 and 5mm × 5mm QFN-32 Packages