

# Black and White Video Camera High Resolution



## Features:

- The 1/3-inch black and white CCD video camera is designed for use in a monitoring system
- High resolution and high sensitivity with 1/3-inch SONY CCD sensor and IC
- Electronic iris adjustment by automatic shutter speed control
- AGC (automatic gain control)
- Accepts C or CS mount lens
- Low light, high sensitivity
- Compact and light-weight
- Low power consumption
- Back light compensation
- Not supplied with lens

## Specifications:

Image device	: 1/3 inches interline transfer SONY CCD
Signal system	: CCIR or EIA standard
Picture element	: EIA : 752 (H) × 582 (V)
	: CCIR : 768 (H) × 494 (V)
Sync System	: Internal
Horizontal resolution	: 550 TV lines
Minimum illumination	: 0.02 lux at F 1.4
S/N ratio	: Better than 46dB
AE electronic iris mode	: 1/50 (CCIR), 1/60 (EIA) to 1/100,000 seconds
Auto iris lens	: Video/DC drive lens available
Gamma	: 0.45
Back light compensation	: ON-OFF interchangeable
Video output signal	: Composite : 1V p-p, 75Ω load
Lens mount	: C and CS mount acceptable
Operation temperature	: -10°C to 50°C (14°F to 122°F)
Power supply	: 12V DC, 24V AC, 220V, 240V (options)
Maximum Power consumption	: 3.6W, 110mA
Dimensions	: 117mm (L) × 57mm (W) × 57mm (H)

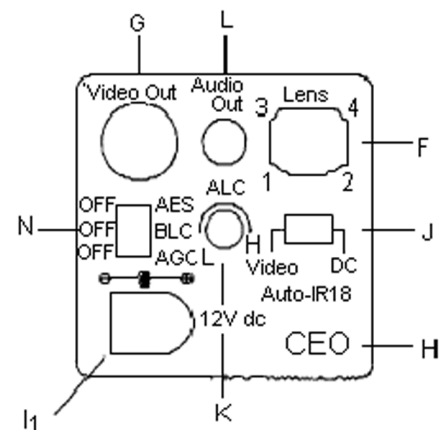
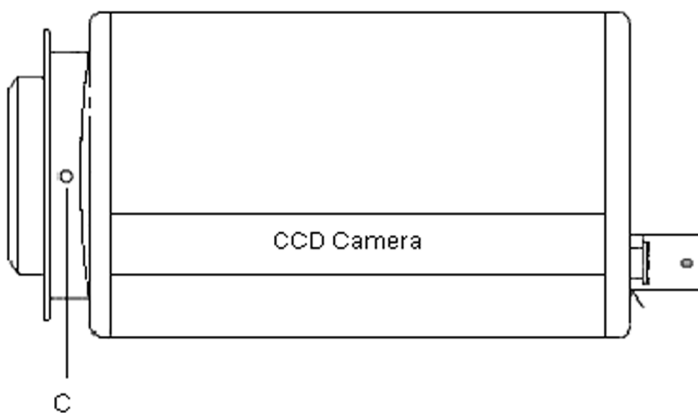

# Black and White Video Camera High Resolution

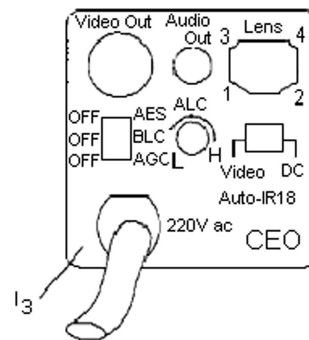
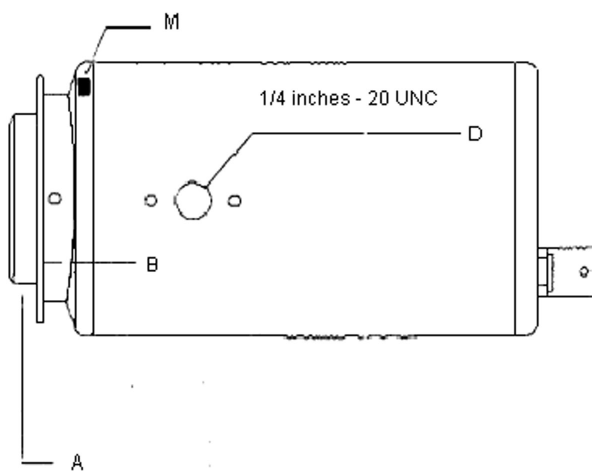
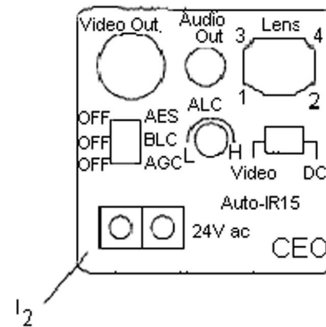
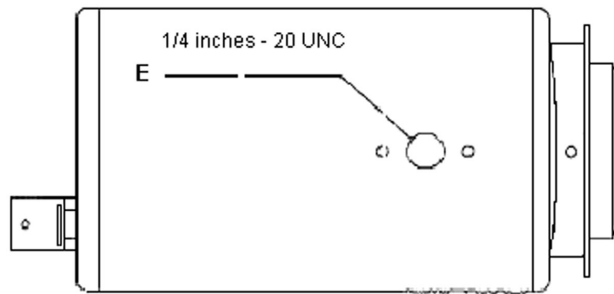

- A - C mount lens ring adapter  
If a C mount lens is used, add the C mount lens ring adapter
- B - Flange back adjusting ring  
If back focus adjustment is required, loosen the flange back locking screw and then back focus can be adjusted by rotating the ring
- C - Flange back locking screw
- D - Mounting bracket screw hole (1/4 inches - 20 UNC) (Bottom)
- E - Mounting bracket screw hole (1/4 inches - 20 UNC) (Top)
- F - Auto iris lens connector (Mini jack)
- G - Video output terminal (BNC)
- H - Power supply indicator
- I - Power input terminal.
  - I<sub>1</sub> : +12V DC (±, Don't mis-connect 12V DC)
  - I<sub>2</sub> : 24V AC
  - I<sub>3</sub> : 110V ac, 220V AC and 240V AC
- J - Video/DC drive auto iris lens selector
- K - For DC-Drive lens, DC level adjuster
- L - Audio output terminal-for Audio type only (RCA Jack)
- M - Micphone-for Audio type only
- N - Function control DIP switch



# Black and White Video Camera High Resolution



Code	Function
AES	Auto electronic shutter ON-OFF
BLC	Back light compensation ON-OFF
AGC	Auto gain control ON-OFF

## Installing Lens:

Remove the lens cap from the front of the camera.

If using a "C" mount lens, this may be screwed directly into the camera.

If using a "CS" mount lens, have to remove a "C" mount lens ring adapter.

When using a fixed iris lens, switch the shutter control to AES ON.

When using a manual adjustable iris lens, switch the shutter control to AES OFF.

When using a Video Servo auto-Iris lens or DC servo auto-iris lens, switch the shutter control to AES OFF.

## Auto Iris Lens Connection:

### 1. Video servo auto iris lens (with EE amp)

Set the lens selector to "Video" position

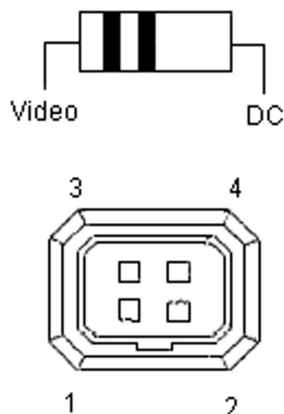

Pin	Definitions	Lens Cable Leads
1	+12V DC	Red
2	Video Iris	White
3	NC	-
4	Ground	Black

### 2. DC servo auto iris lens (without EE amp)

Set the lens selector to "DC" position.

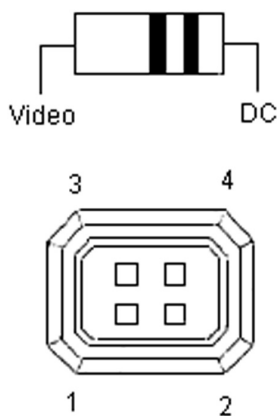

Pin	Definitions
1	Damping -
2	Damping +
3	Driving +
4	Driving -

# Black and White Video Camera High Resolution



## Connections:

1. Keep the camera's power "OFF" during installation
2. Ensure the input voltage is correct for the plug pack or else both the camera and the plug may be damaged
3. Terminate the camera output to 75Ω

Use 75Ω coaxial cable (RG-59/U, RG-6/U, RG-11/U). Always set the last monitor termination switch to 75Ω and set the termination switches of intermediate monitors to high (HI-Z)

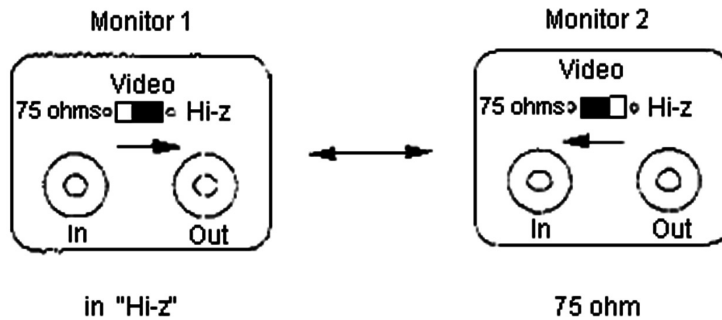

Type of Coaxial Cable	RG-59/U (3C-2V)	RG-6/U (5C-2V)	RG-11/U (7C-2V)
Recommended Maximum Cable Length	Length 330ft (100m)	660ft (200m)	825ft (250m)

## Trouble Shooting

Problem	Where to check
No picture on the monitor	<ul style="list-style-type: none"> <li>Is the system power on?</li> <li>Is the cable connected properly?</li> <li>Has the lens cap been removed?</li> <li>Is the illumination proper?</li> <li>Is the monitor properly adjusted?</li> </ul>
.A picture is not clear	<ul style="list-style-type: none"> <li>Is the lens mount ring proper?</li> <li>Is the lens clear?</li> <li>Is the lens properly focused?</li> <li>Is the monitor terminated properly?</li> </ul>

**Notes:** If dust adheres to the lens, the picture quality will be adversely affected. Wipe the lens lightly with a soft cloth or commercially available lens cleaning paper.

## Part Number Table

Description	Part Number
Camera, 570TVL, AI/DD, 240V	M3806/240

**Important Notice :** This data sheet and its contents (the "Information") belong to the members of the Premier Farnell group of companies (the "Group") or are licensed to it. No licence is granted for the use of it other than for information purposes in connection with the products to which it relates. No licence of any intellectual property rights is granted. The Information is subject to change without notice and replaces all data sheets previously supplied. The Information supplied is believed to be accurate but the Group assumes no responsibility for its accuracy or completeness, any error in or omission from it or for any use made of it. Users of this data sheet should check for themselves the Information and the suitability of the products for their purpose and not make any assumptions based on information included or omitted. Liability for loss or damage resulting from any reliance on the Information or use of it (including liability resulting from negligence or where the Group was aware of the possibility of such loss or damage arising) is excluded. This will not operate to limit or restrict the Group's liability for death or personal injury resulting from its negligence. Defender security is the registered trademark of the Group. © Premier Farnell plc 2012.

