



UM10469

48 V/150 W demo board using the SSL4101

Rev. 1.1 — 22 May 2012

User manual

Document information

Info	Content
Keywords	SSL4101, GreenChip III+, SSL, low cost, LED driver, mains supply, user manual
Abstract	This document explains the basic operation and application of the 150 W SSL4101 Solid-State Lighting (SSL) driver evaluation board. The SSL4101 is designed to meet the needs of universal mains SSL drivers used in industrial and commercial lighting applications.



Revision history

Rev	Date	Description
v.1.1	20120522	second issue
v.1	20110517	first issue

Contact information

For more information, please visit: <http://www.nxp.com>

For sales office addresses, please send an email to: salesaddresses@nxp.com

1. Introduction

WARNING

Lethal voltage and fire ignition hazard



The non-insulated high voltages that are present when operating this product, constitute a risk of electric shock, personal injury, death and/or ignition of fire.

This product is intended for evaluation purposes only. It shall be operated in a designated test area by personnel qualified according to local requirements and labor laws to work with non-insulated mains voltages and high-voltage circuits. This product shall never be operated unattended.

This document explains the basic operation and application of the 150 W SSL4101 Solid-State Lighting (SSL) driver evaluation board. The device is designed to meet the requirements of universal mains SSL drivers used in industrial and commercial lighting applications. Both Constant Current Mode (CCM) or Constant Voltage Mode (CVM) outputs are supported over power ranges from 100 W to 280 W delivered to the load with minor modifications.

The SSL4101 uses NXP Semiconductors GreenChip III+ Switched Mode Power Supply (SMPS) controller IC technology. The SSL4101 combines a controller for Power Factor Correction (PFC) and a flyback controller. The SSL4101's high level of integration allows design of a cost-effective LED lighting applications in a small form factor using low number of components.

Remark: In this user manual, all voltages are in V (AC) unless otherwise specified.



019aac388

Fig 1. SSL4101 demo board

2. Safety warning

The board can be connected to a mains voltage between 108 V and 305 V. A different mains voltage range can be selected with minor modifications. The output connected to the LEDs is designed for reinforced isolation from the mains. The demo board is designed to meet UL1950, UL8750 and EN61347 but was not submitted for safety compliance. Touching the reference board during operation must be avoided at all times.

An isolated housing for the board and the LED's is mandatory when used in uncontrolled, non-laboratory environments. Therefore the board must be connected to the mains supply via a galvanic isolated (variable) transformer. These devices can be recognized by the symbols shown in [Figure 2](#).

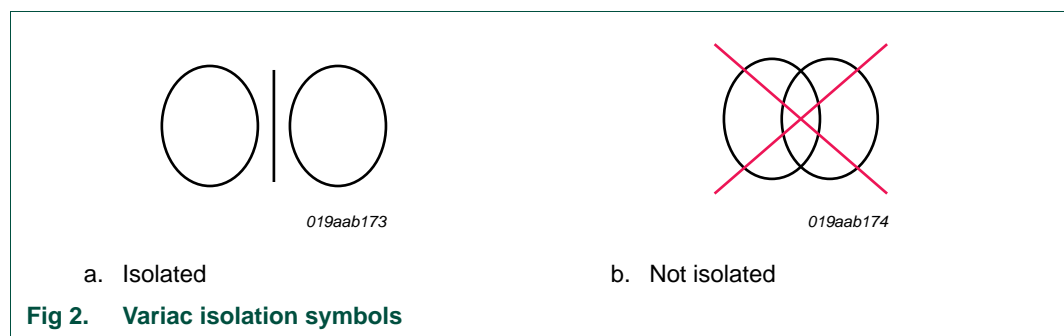

3. SSL4101 driver board specifications

Table 1. SSL4101 driver board specifications

Symbol	Parameter Name	Minimum	Target	Units	Remarks
T_{oper}	operating temperature	-25 to +60; +5 to +95	-40 to +85; +0 to +95	°C/%	ambient temperature; non-condensing relative humidity
V_i	input voltage (mains AC)	108 to 305	85 to 305	V	-
f_i	input frequency	49 to 61	47 to 63	Hz	-
δ_{life}	duty cycle (operational life)	35 000	50;000	hour	< 5 % failure rate at 60 °C; full load
V_o	output voltage	-	48; ± 2 %	V	output voltage must always stay below 60 V to meet the Class II operating requirements
$I_{o(max)}$	maximum output current	3.1	-	A	unit must keep constant voltage output from no-load through maximum output current
η	efficiency	91*/94 **	-	%	* measured with V_i set to 120 V ** measured with V_i set to 277 V (full load)
PF	Power Factor	0.95***	0.9****	-	Measured with V_i set to 120 V; 230 V and 277 V *** at full load **** for loads from 50 % to full load
P_{stb}	standby power	< 500	< 300	mW	power in mW at no-load
$t_{d(start)}$	start-up delay time	< 300	< 200	ms	startup delay time from power-up until I_o is above 90 % of its rated output current measured at maximum load

4. SSL4101 driver overview

The SSL4101 is part of NXP Semiconductors GreenChip III+ (third generation) of green Switched Mode Power Supply (SMPS) controller ICs. The SSL4101T combines both a controller for Power Factor Correction (PFC) and a flyback controller. The integrated green functions provide high-efficiency at all power levels. This applies to quasi-resonant operation at high power levels, quasi-resonant operation with valley skipping, as well as to reduced frequency operation at lower power levels. At low power levels, the PFC switches off to maintain the SSL4101's high-efficiency.

During low power conditions, the flyback controller switches to frequency reduction mode and limits the peak current to 25 % of its maximum value. This ensures high-efficiency at low power and good standby power performance while minimizing audible noise from the transformer.

The SSL4101T is a MultiChip Module (MCM) containing two chips. The proprietary high voltage BCD800 process which makes direct start-up possible from the rectified universal mains voltage in an effective and green way. The second low voltage Silicon On Insulator (SIO) is used for accurate, high speed protection functions and control.

The SSL4101T enables extremely efficient and reliable LED lighting application power supplies with power requirements from 10 W to 300 W to be designed easily using the minimum number of additional components.

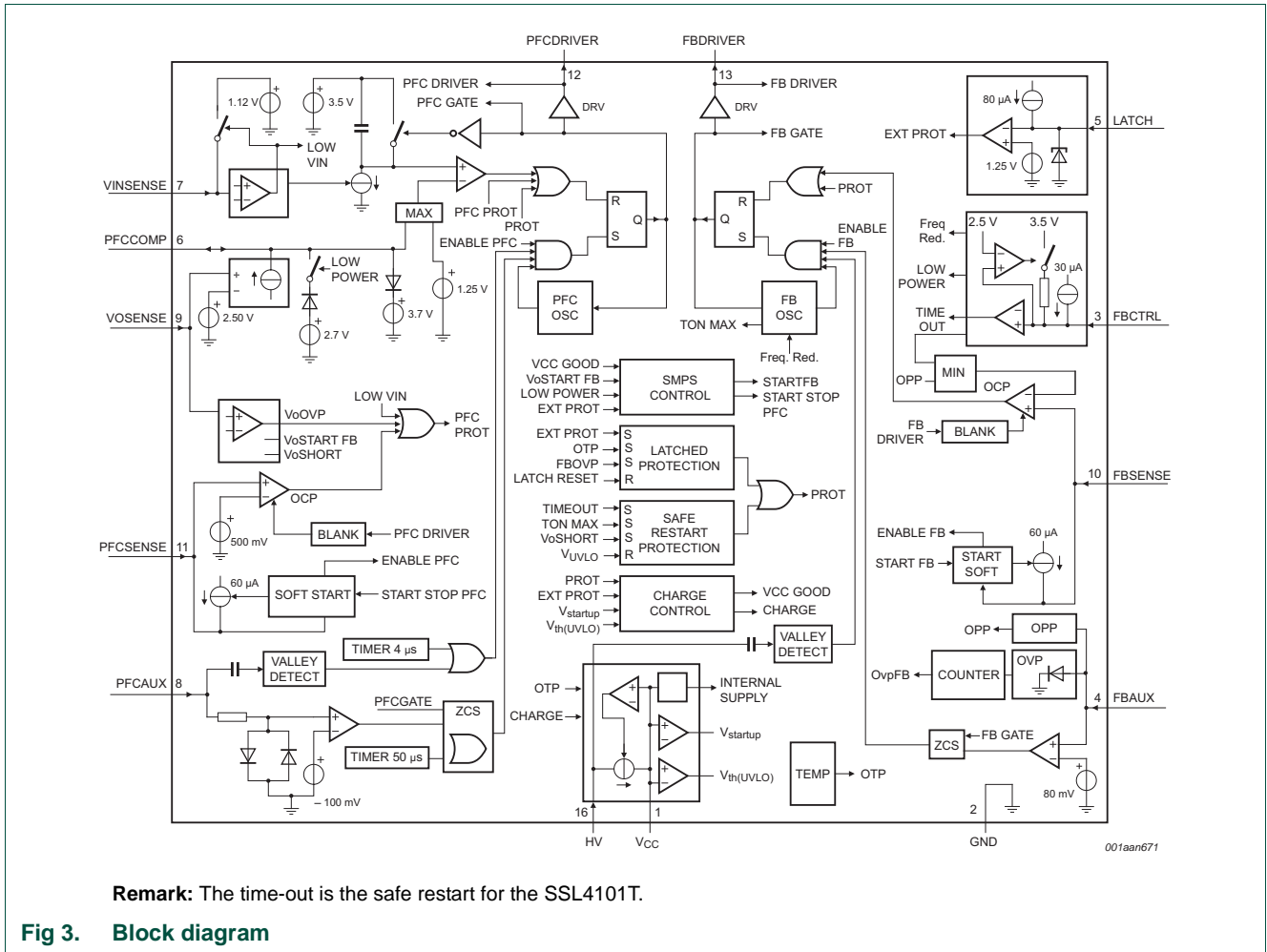

5. Pin description

5.1 Pin configuration

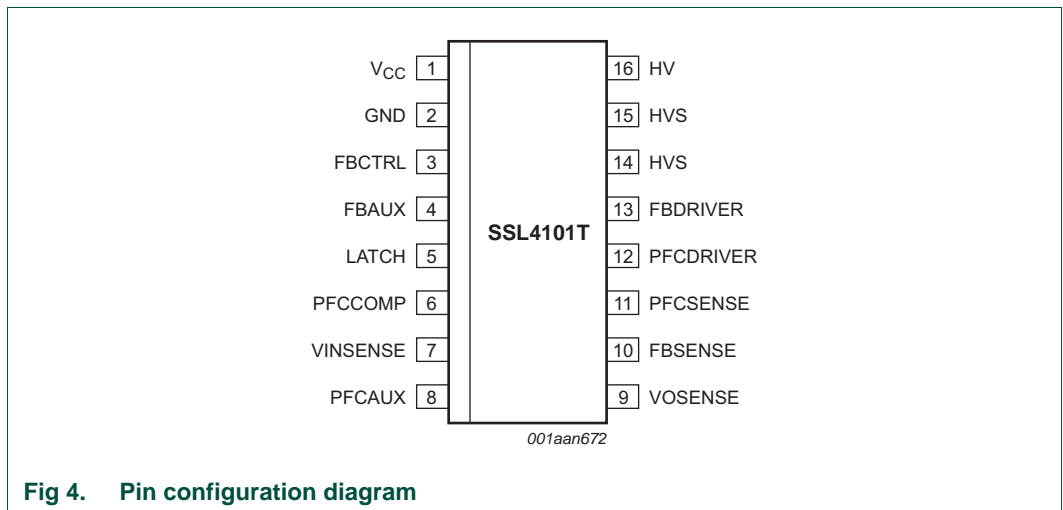

5.2 Pin description

Table 2. Pin description

Symbol	Pin	Description
V _{CC}	1	supply voltage
GND	2	ground
FBCTRL	3	control input for flyback
FBAUX	4	input from auxiliary winding for demagnetization timing and overvoltage protection for flyback
LATCH	5	general purpose protection input
PFCCOMP	6	frequency compensation pin for PFC
VINSENSE	7	sense input for mains voltage
PFC AUX	8	input from auxiliary winding for demagnetization timing for PFC
VOSENSE	9	sense input for PFC output voltage
FBSNSE	10	programmable current sense input for flyback
PFCSENSE	11	programmable current sense input for PFC
PFC DRIVER	12	gate driver output for PFC
FB DRIVER	13	gate driver output for flyback
HVS	14; 15	high voltage safety spacer; not connected
HV	16	high voltage start-up and valley sensing of flyback part

5.3 Schematic SSL4101 demo board

The major components of a typical SSL4101 application are shown in [Figure 5](#). The following remarks are very important when designing your application.

Remark: Minimize both the perimeters and the areas encircled by the indicated loops.

Remark: Power and signal GND must have only one connection between the C22 ground pin and the C7 minus pin.

Remark: In [Figure 5](#) the connections for some capacitors must be soldered directly to the capacitors solder point on the PCB and from that point connected to the next component.

Remark: Components that are not parts of the power loops, particularly the ICs and the filter capacitors must not be enclosed by a power loop. Moreover, they should be kept as far from them as possible.

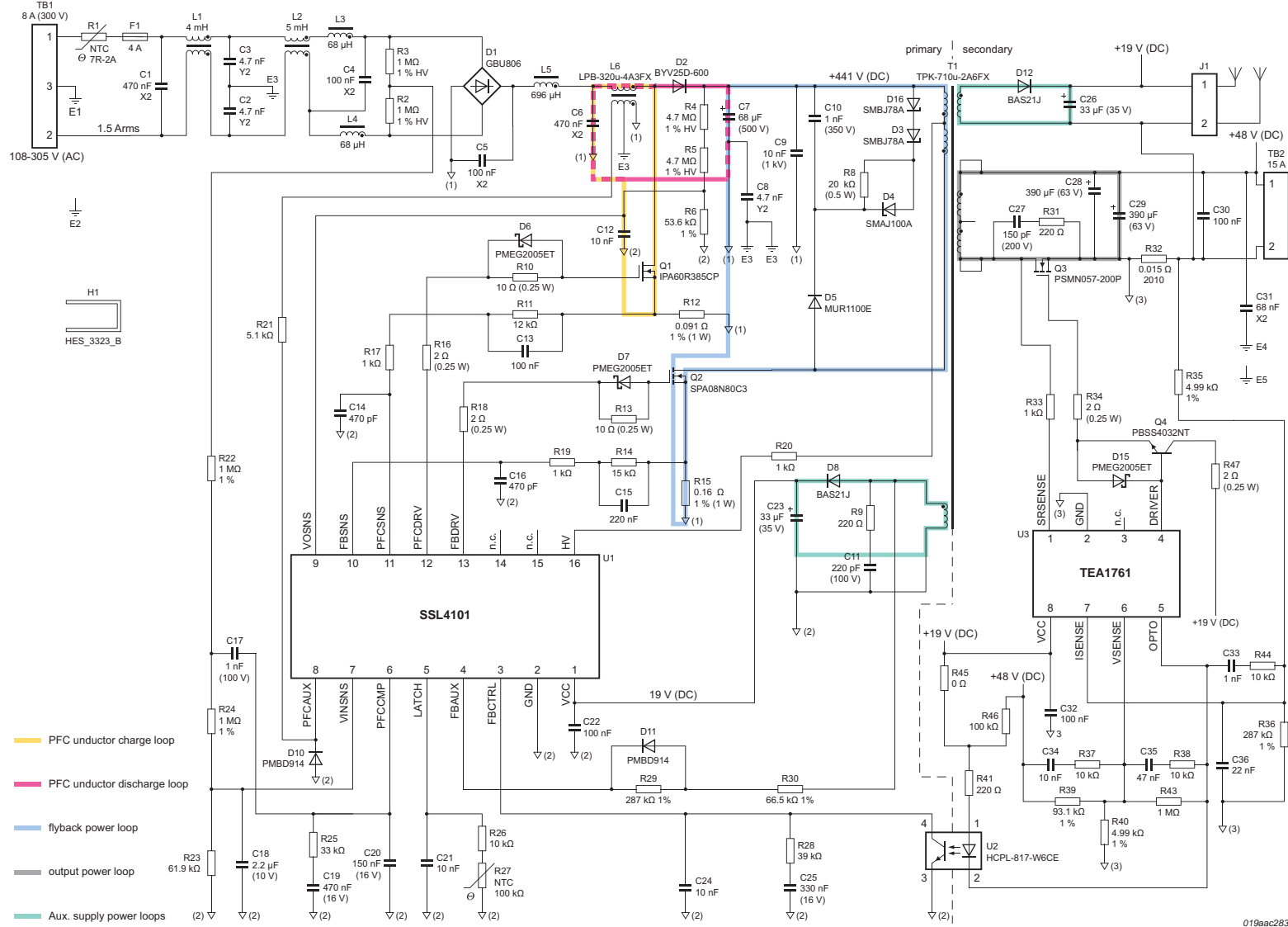

- (1) Primary power GND, all connections go to the C7 minus pin.
- (2) Primary signal GND, all connections go to the C22 ground pin.

Fig 5. Schematic SSL4101 demo board

6. Bill of materials

Table 3. Bill of materials

Component	Qty	Description	Manufacturer and type
C1; C6	2	film capacitor; 470 nF; 305 V (AC); X2	EPCOS; B32922C3474M
C2; C3; C8	3	ceramic capacitor; 4.7 nF; 300 V (AC); Y2; disc	Vishay; VY2472M49Y5US63V7
C4	1	film capacitor; 100 nF; 305 V (AC); X2; 10 mm LdSp	EPCOS; B32921C3104M
C5	1	film capacitor; 100 nF; 305 V (AC); X2; 15 mm LdSp	EPCOS; B32922A2104M
C7	1	electrolytic capacitor; 68 μ F; 500 V; 0.78 A to 1.1 A (RMS)	Panasonic; ECO-S2HP680CA
C9	1	ceramic capacitor; 10 nF; 1 kV; -20 to +80 %; disc	Murata; DEBE33A103ZA3B
C10	1	ceramic capacitor; 1 nF; 300 V (AC); Y2; disc	Vishay; VY2102M29Y5US63V7
C11	1	MLCC; 220 pF; 100 V; 10 %; X7R; SMD 0805	AVX; 08051C221KAT2A
C12; C21; C24	3	MLCC; 10 nF; 50 V; 10 %; X7R; SMD 0805	AVX; 08055C103KAT2A
C13; C22	2	MLCC; 100 nF; 100 V; 10 %; X7R; SMD 0805	TDK; C2012X7R2A104K
C14; C16	2	MLCC; 470 pF; 100 V; 5 %; NPO; SMD 0805	TDK; C2012COG2A471J
C15	1	MLCC; 220 nF; 16 V; 10 %; X7R; SMD 0805	Murata; GRM219R71C224KA01D
C17; C33	2	MLCC; 1 nF; 100 V; 10 %; X7R; SMD 0805	AVX; 08051C102KAT2A
C18	1	MLCC; 2.2 μ F; 10 V; 10 %; X7R; SMD 0805	Murata; GRM21BR71A225KA01L
C19	1	MLCC; 470 nF; 16 V; 10 %; X7R; SMD 0805	Panasonic; ECJ-2FB1C474K
C20	1	MLCC; 150 nF; 16 V; 10 %; X7R; SMD 0805	AVX; 0805YC153KAT2A
C23; C26	2	electrolytic capacitor; 33 μ F; 35 V; 105 $^{\circ}$ C; 0.175 A (RMS)	Nippon Chemi-Con; ELXZ350ELL330MEB5D
C25	1	MLCC; 330 nF; 16 V; 10 %; X7R; SMD 0805	AVX; 0805YC334KAT2A
C27	1	MLCC; 150 pF; 200 V; 10 %; NPO; SMD 1206	-
C31	1	film capacitor; 68 nF; 305 V (AC); X2	Vishay; BFC233820683
C28; C29	2	electrolytic capacitor; 390 μ F; 63 V; 1.9 A (RMS)	Nippon Chemi-Con; EKZE630ELL391MK25S
C30; C32	2	MLCC; 100 nF; 100 V; 10 %; X7R; SMD 0805	TDK; C2012X7R2A104K
C35	1	MLCC; 47 nF; 50 V; 10 %; X7R; SMD 0805	AVX; 08055C473KAT2A
C34	1	MLCC; 10 nF; 50 V; 10 %; X7R; SMD 0805	AVX; 08055C103KAT2A
C36	1	MLCC; 22 nF; 50 V; 10 %; X7R; SMD 0805	AVX; 08055C223KAT2A
D1	1	diode bridge; 8 A; 600 V; GBU806	Diodes Incorporated; GBU806
D2	1	diode; 5 A; 600 V; ultrafast; DPAK	NXP Semiconductors; BYV25D-600
D3; D16	2	diode; Zener; 91 V; 5 %; 5 W; SMB	Littelfuse; SMBJ78A
D4	1	diode; Zener; 117 V; 5 %; 3 W; SMA	Littelfuse; SMAJ100A
D5	1	diode; 1 A; 1 kV; ultrafast; DO-41	ON Semiconductor; MUR1100E
D6; D7	2	diode; Schottky; 0.5 A; 20 V; SOT23	NXP Semiconductors; PMEG2005ET
D8; D12	2	diode; 0.25 A; 300 V; fast recovery; SOD323F	NXP Semiconductors; BAS21J
D10; D11	2	diode; 0.2 A; 100 V; high speed switching; SOT23	NXP Semiconductors; PMBD914
D15	1	diode; Schottky; 0.5 A; 20 V; SOT23	NXP Semiconductor; PMEG2005ET
F1	1	fuse; 4 A; 300 V; time-lag	Littelfuse; 3691400044

Table 3. Bill of materials ...continued

Component	Qty	Description	Manufacturer and type
H1	1	heatsink spreader; D1; Q1; Q2; D13/Q3	Custom; HCC-8706-BkA1
case	1	case; 12.45 mm × 6.35 mm × 3.89 mm (4.90" × 2.50" × 1.53"); yellow anodized	Custom; HCC-4925-YelA1
case top	1	case top; 12.45 mm × 6.05 mm × 0.51 mm (4.90" × 2.38" × 0.20"); yellow anodized	Custom; HCC-4924-YelA1
J1	1	connector; RCPT; 2 POS; .100";SNGL GOLD	Samtec Inc; CES-102-01-S-S
L1	1	inductor; common mode; 4 mH; 2 A; 10 kμ; split	Würth Elektronik 750312184
L2	1	inductor; common mode; 5 mH; 2 A; 10 kμ; bifilar	Würth Elektronik 750312185
L3; L4	2	inductor; differential mode; 68 μH; 2 A	Murata; 13R683C
L5	1	inductor; differential mode; 696 μH; 2 A; high flux 160 u	Würth Elektronik 750341186
L6	1	inductor; 320 μH; RM10-3C95; 47.5T; 40/38 SPNSN Served Litz	Würth Elecktronik 750312188
R1	1	NTC resistor; 7 Ω; 2 A	Ametherm; SL08 7R002
R2; R3	2	resistor; 1 MΩ; 1 %; SMD 1206; high voltage	Rohm; KTR18EZPF1004
R4; R5	2	resistor; 4.7 MΩ; 1 %; SMD 1206; high voltage	Rohm; KTR18EZPF4704
R6	1	resistor; 53.6 kΩ; 0.125 W; 1 %; SMD 0805	Yageo; RC0805FR-0753K6L
R8	1	resistor; 20 kΩ; 0.5 W; 1 %; SMD 1206	Stackpole Electronics; RNCP1206FTD20K0
R9	1	resistor; 220 Ω; 0.125 W; 5 %; SMD 0805	Stackpole Electronics; RMCF0805JT220R
R10; R13	2	resistor; 10 Ω; 0.25 W; 5 %; SMD 1206	Stackpole Electronics; RMCF1206JT10R0
R11	1	resistor; 12 kΩ; 0.125 W; 5 %; SMD 0805	Stackpole Electronics; RMCF 1/10 12K 5% R
R14	1	resistor; 15 kΩ; 0.125 W; 5 %; SMD 0805	Stackpole Electronics; RMCF 1/10 15K 5% R
R12	1	resistor; 0.091 Ω; 1 W; 1 %; SMD 2010	Stackpole Electronics; CSRN2010FKR091
R15	1	resistor; 0.16 Ω; 1 W; 1 %; SMD 2010	Stackpole Electronics; CSRN2010FKR160
R16; R18	2	resistor; 2 Ω; 0.25 W; 5 %; SMD 1206	Panasonic; ERJ-8GEYJ2R0V
R17; R19; R20	3	resistor; 1 kΩ; 0.125 W; 5 %; SMD 0805	Stackpole Electronics; RMCF 1/10 1K 5% R
R21	1	resistor; 5.1 kΩ; 0.125 W; 5 %; SMD 0805	Stackpole Electronics; RMCF 1/10 5.1K 5% R
R22; R24	2	resistor; 1 MΩ; 1 %; SMD 0805	Stackpole Electronics; RMCF0805FT1M00
R23	1	resistor; 61.9 kΩ; 0.125 W; 1 %; SMD 0805	Yageo; RC0805FR-0761K9L
R25	1	resistor; 33 kΩ; 0.125 W; 5 %; SMD 0805	Stackpole Electronics; RMCF 1/10 33K 5% R
R26	1	resistor; 10 kΩ; 0.125 W; 1 %; SMD 0805	Stackpole Electronics; RMCF 1/10 10K 1% R
R27	1	NTC Resistor; 100 kΩ; 5 %; 3950-4400 B25/50	Cantherm; MF52A104J3950
R28	1	resistor; 39 kΩ; 0.125 W; 5 %; SMD 0805	Stackpole Electronics; RMCF 1/10 39K 5% R
R29; R36	2	resistor; 287 kΩ; 0.125 W; 1 %; SMD 0805	Stackpole Electronics; RMCF0805FT287K
R30	1	resistor; 66.5 kΩ; 0.125 W; 1 %; SMD 0805	Yageo; RC0805FR-0766K5L
R31; R41	2	resistor; 220 Ω; 0.125 W; 5 %; SMD 0805	Stackpole Electronics; RMCF 1/10 220 5% R
R33	1	resistor; 1 kΩ; 0.125 W; 5 %; SMD 0805	Stackpole Electronics; RMCF 1/10 1K 5% R
R32	1	resistor; 0.015 Ω; 1 W; 1 %; SMD 2010	Stackpole Electronics; CSRN2010FKR015
R34; R47	2	resistor; 2 Ω; 0.25 W; 5 %; SMD 1206	Panasonic; ERJ-8GEYJ2R0V
R35; R40	2	resistor; 4.99 kΩ; 0.125 W; 1 %; SMD 0805	Stackpole Electronics; RMCF 1/10 4.99K 1% R
R37; R38; R44	3	resistor; 10 kΩ; 0.125 W; 1 %; SMD 0805	Stackpole Electronics; RMCF 1/10 10K 1% R
R39	1	resistor; 93.1 kΩ; 0.125 W; 1 %; SMD 0805	Stackpole Electronics; RMCF0805FG93K1

Table 3. Bill of materials ...continued

Component	Qty	Description	Manufacturer and type
R43	1	resistor; 1 M Ω ; 1 %; SMD 0805	Stackpole Electronics; RMCF0805FT1M00
R45	1	resistor; 0 Ω ; SMD 0805	Stackpole Electronics; Jumper
R46	1	resistor; 100 k Ω ; 0.125 W; 1 %; SMD 0805	Stackpole Electronics; RMCF0805FT100K
PCB1	1	PCB; double-sided	SMPS designed; ADx-yyyW-PCBC1
Q1	1	MOSFET; 650 V; 5.7 A; 0.63 Ω at 100 $^{\circ}$ C; TO220F	Infineon; IPA60R385CP
Q2	1	MOSFET; 800 V; 5.1 A; 1.08 Ω at 100 $^{\circ}$ C; TO220F	Infineon; SPA08N80C3
Q3	1	MOSFET; 200 V; 27 A; 73 m Ω at 100 $^{\circ}$ C; TO220	NXP Semiconductor; PSMN057-200P
Q4	1	NPN; 30 V; 2 A; SOT23	NXP Semiconductor; PBSS4032NT
T1	1	transformer; flyback; PQ32/20-3C95; 710 μ H; 40 : 10: 4 : 4	Würth Elektronik 750341026
TB1	1	terminal block; 3 \times 15 A; 300 V (AC)	On-Shore Technology; OSTTC032162
TB2	1	terminal block; 2 \times 16 A; 250 V (AC)	On-Shore Technology; OSTTC020162
U1	1	IC; GreenChip III SMPS Controller	NXP Semiconductors; SSL4101
U2	1	optocoupler; CTR = 200-400	Avago Technologies; HCPL-817-W6CE
U3	1	IC; GreenChip synchronous rectifier controller	NXP Semiconductor; TEA1761T
(C7)	1	nomex insulator; 0.254 mm (10 mil); \varnothing 2.67 mm (\varnothing 1.050")	-
(case top)	6	screw; #2-56; 3.17 mm (1/8") length; flat head; undercut; stainless steel	McMaster; 91771A074
	1	copper shield; 0.127 mm (5 mil); 5.51 mm \times 1.78 mm (2.170" \times 0.700")	-
(case)	2	nomex strip; 1.63 mm \times 12.31 mm (0.640" \times 4.850")	-
(D1; Q1; Q2; D13/Q3)	4	screw; #4-40; 7.94 mm (5/16") length; flat head; undercut; stainless steel	McMaster; 91099A160
(D1; Q1; Q2; D13/Q3)	4	belleville washer; #4	McMaster; 9713K54
(D1; Q1; Q2; D13/Q3)	4	hex nut; #4; stainless steel	McMaster; 91841A005
(E1-E5)	5	screw; #4-40; 6.35 mm (1/4"); pan head; external washer; zinc plated steel	McMaster; 90402A106
(H1)	6	screw; #4-40; 1/8" length; flat head; undercut; stainless steel	McMaster; 91771A103
(L5)	1	nomex insulator; 0.254 mm (10 mil); 1.27 mm \times 2.54 mm (0.500" \times 1.000")	-
(L6)	1	nomex insulator; 0.254 mm (10 mil); 2.54 mm \times 2.54 mm (1.000" \times 1.000")	-
(R27)	2	heatshrink tubing; \varnothing 0.127 mm (\varnothing 0.050"); long 0.76 mm (0.300")	-
(T1)	1	nomex insulator; 0.254 mm (10 mil); 3.43 mm \times 3.56 mm (1.350" \times 1.400")	-

7. Operation and connection

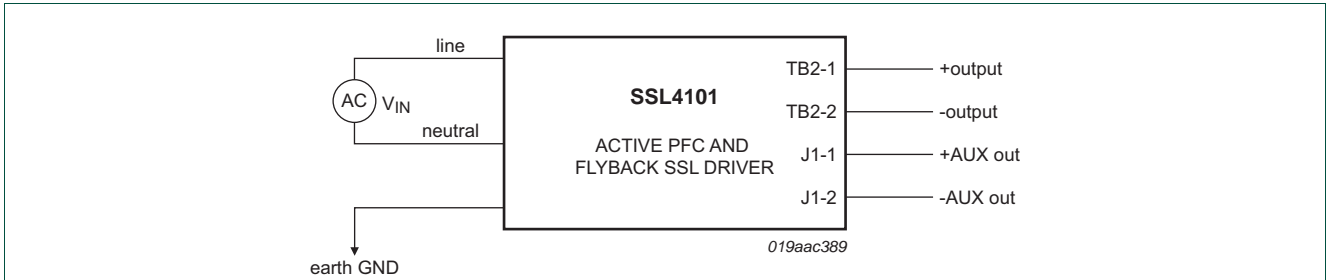
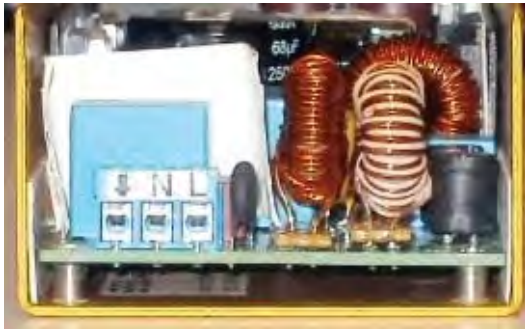
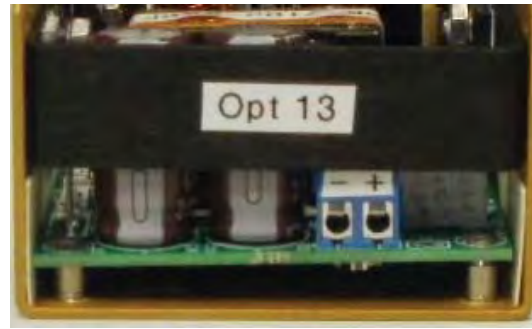

Fig 6. General connection of the SSL4101 demo board



019aac390

Fig 7. Input side



019aac391

Fig 8. Output side

8. Measurements

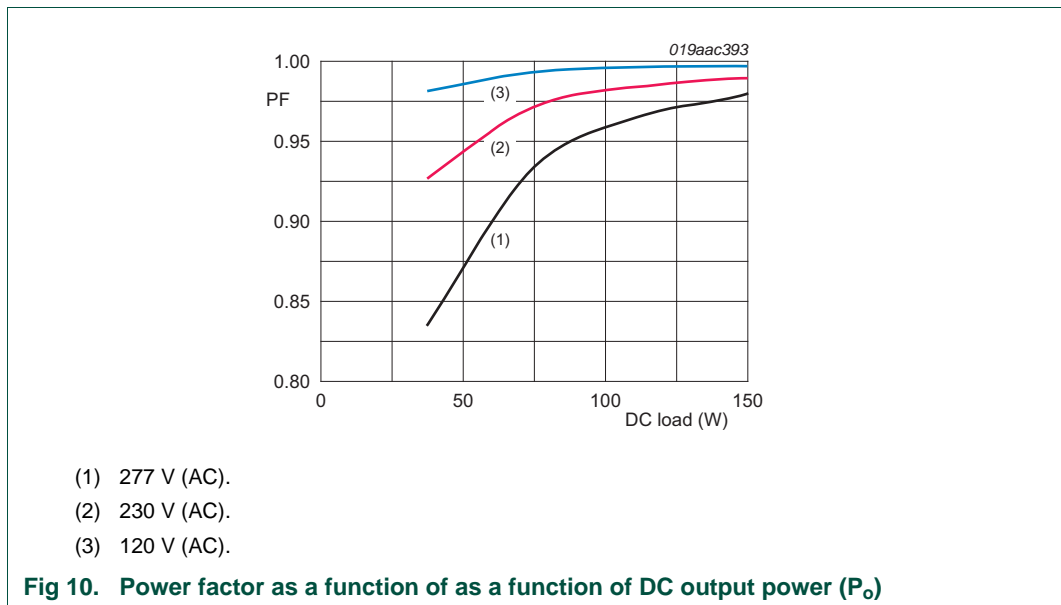
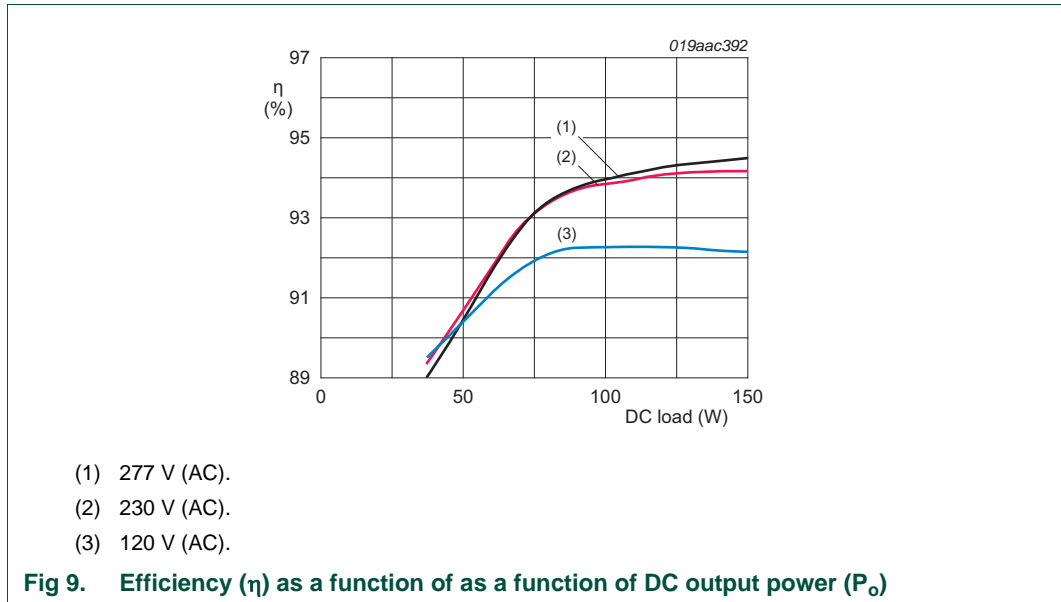

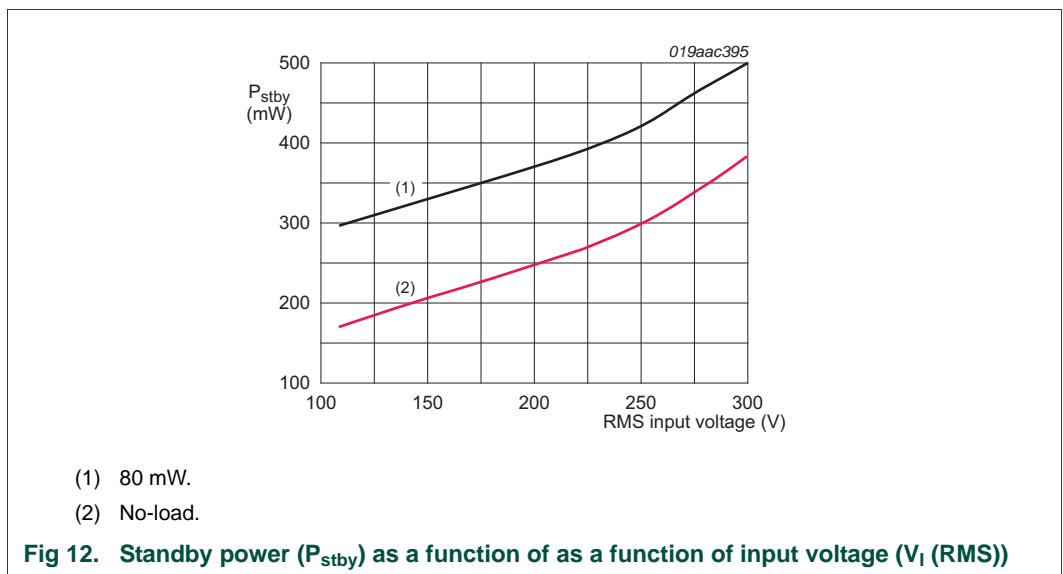
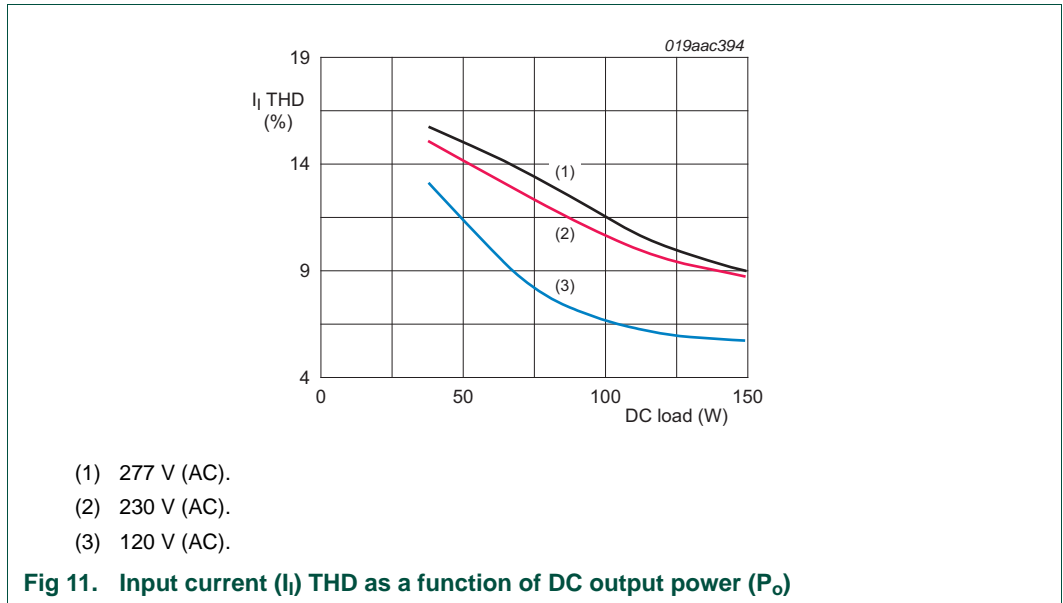

9. PCB layouts

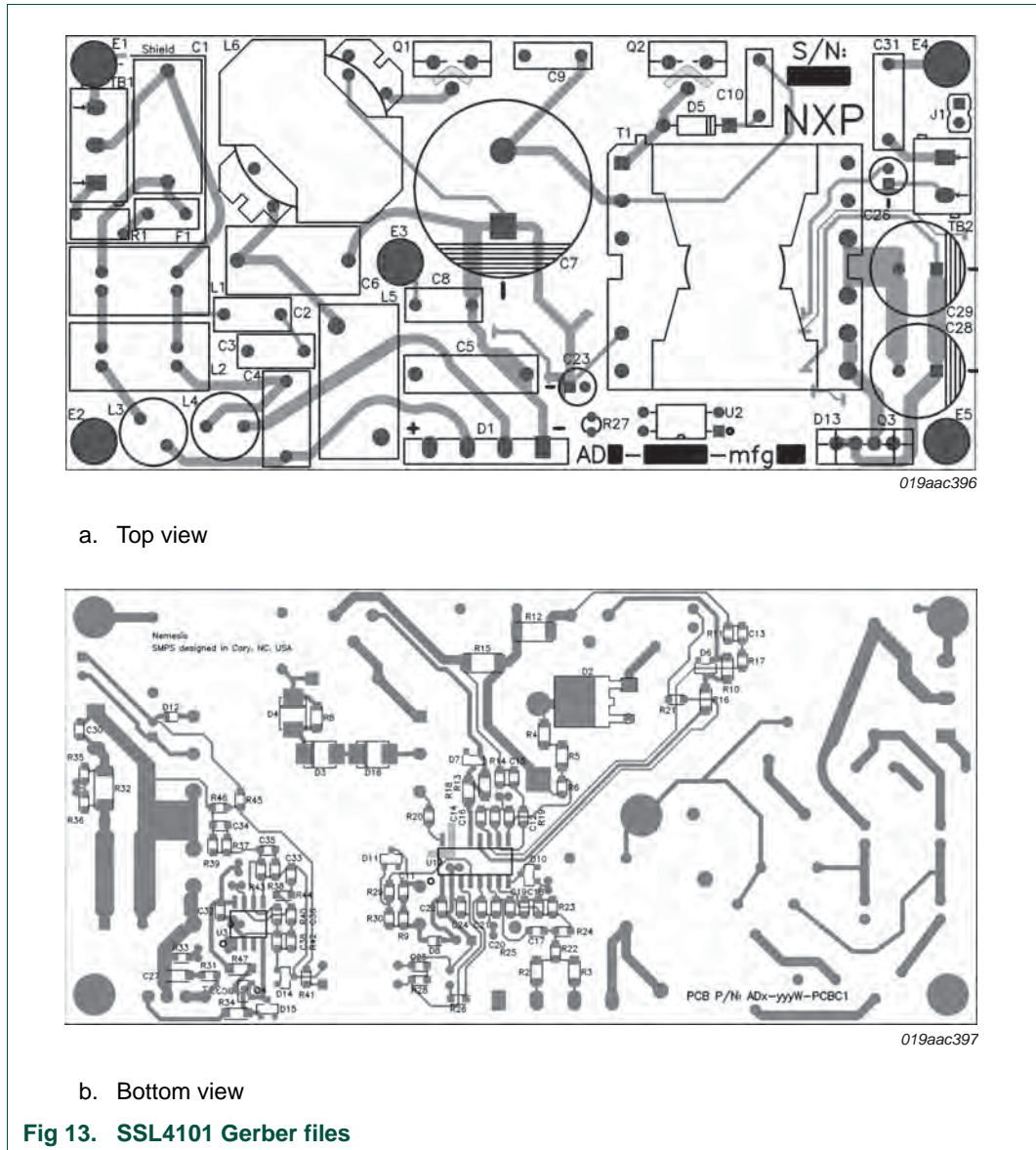

10. References

- [1] AN11054 — GreenChip III+ SSL4101 integrated PFC and flyback controller application note.
- [2] SSL4101T — Data sheet.

11. Legal information

11.1 Definitions

Draft — The document is a draft version only. The content is still under internal review and subject to formal approval, which may result in modifications or additions. NXP Semiconductors does not give any representations or warranties as to the accuracy or completeness of information included herein and shall have no liability for the consequences of use of such information.

11.2 Disclaimers

Limited warranty and liability — Information in this document is believed to be accurate and reliable. However, NXP Semiconductors does not give any representations or warranties, expressed or implied, as to the accuracy or completeness of such information and shall have no liability for the consequences of use of such information. NXP Semiconductors takes no responsibility for the content in this document if provided by an information source outside of NXP Semiconductors.

In no event shall NXP Semiconductors be liable for any indirect, incidental, punitive, special or consequential damages (including - without limitation - lost profits, lost savings, business interruption, costs related to the removal or replacement of any products or rework charges) whether or not such damages are based on tort (including negligence), warranty, breach of contract or any other legal theory.

Notwithstanding any damages that customer might incur for any reason whatsoever, NXP Semiconductors' aggregate and cumulative liability towards customer for the products described herein shall be limited in accordance with the *Terms and conditions of commercial sale* of NXP Semiconductors.

Right to make changes — NXP Semiconductors reserves the right to make changes to information published in this document, including without limitation specifications and product descriptions, at any time and without notice. This document supersedes and replaces all information supplied prior to the publication hereof.

Suitability for use — NXP Semiconductors products are not designed, authorized or warranted to be suitable for use in life support, life-critical or safety-critical systems or equipment, nor in applications where failure or malfunction of an NXP Semiconductors product can reasonably be expected to result in personal injury, death or severe property or environmental damage. NXP Semiconductors and its suppliers accept no liability for inclusion and/or use of NXP Semiconductors products in such equipment or applications and therefore such inclusion and/or use is at the customer's own risk.

Applications — Applications that are described herein for any of these products are for illustrative purposes only. NXP Semiconductors makes no representation or warranty that such applications will be suitable for the specified use without further testing or modification.

Customers are responsible for the design and operation of their applications and products using NXP Semiconductors products, and NXP Semiconductors accepts no liability for any assistance with applications or customer product design. It is customer's sole responsibility to determine whether the NXP Semiconductors product is suitable and fit for the customer's applications and products planned, as well as for the planned application and use of customer's third party customer(s). Customers should provide appropriate design and operating safeguards to minimize the risks associated with their applications and products.

NXP Semiconductors does not accept any liability related to any default, damage, costs or problem which is based on any weakness or default in the customer's applications or products, or the application or use by customer's third party customer(s). Customer is responsible for doing all necessary testing for the customer's applications and products using NXP Semiconductors products in order to avoid a default of the applications and the products or of the application or use by customer's third party customer(s). NXP does not accept any liability in this respect.

Export control — This document as well as the item(s) described herein may be subject to export control regulations. Export might require a prior authorization from competent authorities.

Evaluation products — This product is provided on an "as is" and "with all faults" basis for evaluation purposes only. NXP Semiconductors, its affiliates and their suppliers expressly disclaim all warranties, whether express, implied or statutory, including but not limited to the implied warranties of non-infringement, merchantability and fitness for a particular purpose. The entire risk as to the quality, or arising out of the use or performance, of this product remains with customer.

In no event shall NXP Semiconductors, its affiliates or their suppliers be liable to customer for any special, indirect, consequential, punitive or incidental damages (including without limitation damages for loss of business, business interruption, loss of use, loss of data or information, and the like) arising out of the use of or inability to use the product, whether or not based on tort (including negligence), strict liability, breach of contract, breach of warranty or any other theory, even if advised of the possibility of such damages.

Notwithstanding any damages that customer might incur for any reason whatsoever (including without limitation, all damages referenced above and all direct or general damages), the entire liability of NXP Semiconductors, its affiliates and their suppliers and customer's exclusive remedy for all of the foregoing shall be limited to actual damages incurred by customer based on reasonable reliance up to the greater of the amount actually paid by customer for the product or five dollars (US\$5.00). The foregoing limitations, exclusions and disclaimers shall apply to the maximum extent permitted by applicable law, even if any remedy fails of its essential purpose.

11.3 Trademarks

Notice: All referenced brands, product names, service names and trademarks are the property of their respective owners.

GreenChip — is a trademark of NXP B.V.

12. Contents

1	Introduction	3
2	Safety warning	4
3	SSL4101 driver board specifications	4
4	SSL4101 driver overview	5
5	Pin description	6
5.1	Pin configuration	6
5.2	Pin description	7
5.3	Schematic SSL4101 demo board	7
6	Bill of materials	9
7	Operation and connection	11
8	Measurements	13
9	PCB layouts	15
10	References	15
11	Legal information	16
11.1	Definitions	16
11.2	Disclaimers	16
11.3	Trademarks	16
12	Contents	17

Please be aware that important notices concerning this document and the product(s) described herein, have been included in section 'Legal information'.

© NXP B.V. 2012.

All rights reserved.

For more information, please visit: <http://www.nxp.com>

For sales office addresses, please send an email to: salesaddresses@nxp.com

Date of release: 22 May 2012

Document identifier: UM10469