

CAN Bus Driver and Receiver

FEATURES

- Survives Ground Shorts and Transients on Multiplexed Bus in Automotive and Industrial Applications
- Single Power Supply
- Compatible with Intel 82526 CAN Controller
- Direct Interface – No External Components Required
- Automotive Temperature Range (–40 to 125°C)

DESCRIPTION

The Si9200EY is designed to interface between the Intel 82526 CAN controller and the physical bus to provide drive capability to the bus and differential receive capability to the controller. It is designed to absorb typical electrical transients on the bus which may occur in an automotive or industrial application, and protect itself against any abnormal bus conditions. The transmitter will be disabled during these conditions and will be re-enabled when the abnormal condition is cleared.

The Si9200EY is built using the Siliconix BiC/DMOS process. This process supports CMOS, DMOS, and isolated bipolar transistors and uses an epitaxial layer to prevent latchup. The bus line pins are diode protected and can be driven beyond the V_{DD} to ground range.

The Si9200EY is offered in the space efficient 8-pin high-density surface-mount plastic package and is specified over the automotive temperature range (–40 to 125°C). The Si9200EY is available in lead free.

PIN CONFIGURATION AND FUNCTIONAL BLOCK DIAGRAM

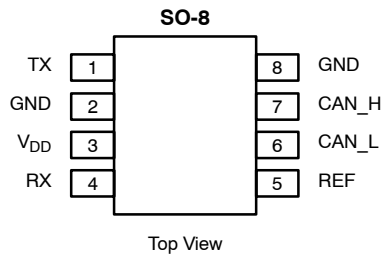

Ordering Information: Si9200EY-T1
Si9200EY-T1—E3 (Lead Free)

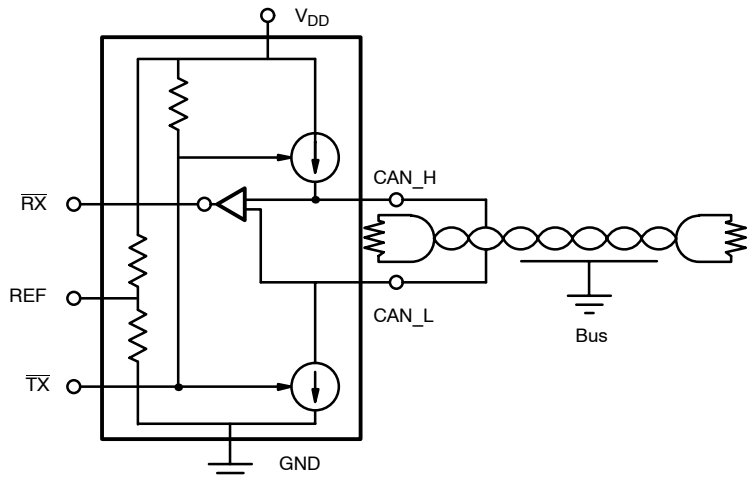



ABSOLUTE MAXIMUM RATINGS^a

Operating Temperature (T_A) -40 to 125°C
 Junction and Storage Temperature -55 to 150°C
 Voltage On Any Pin (Except CAN_H and CAN_L)
 with Respect to Ground -0.3 to V_{DD} +0.3 V
 Voltage On CAN_H and CAN_L
 with Respect to Ground -3 to +16 V
 Supply Voltage, V_{DD} -0.3 to 12 V

Continuous Output Current ±100 mA
 Thermal Ratings^b: R_{θJA} 62.5°C/W (no airflow)

- Notes
 a. Extended exposure to the absolute maximum ratings or stresses beyond these ratings may affect device reliability or may cause permanent damage to the device. Functional operation at conditions other than the recommended operating conditions is not implied.
 b. Mounted on 1-IN², FR4 PC Board.

RECOMMENDED OPERATING CONDITIONS

V_{DD} 4.75 to 5.25 V
 Bus Load Resistance 60 Ω

SPECIFICATIONS						
Parameter	Symbol	Test Conditions Unless Otherwise Specified V _{DD} = 4.75 to 5.25 V	Limits T _A = -40 to 125°C			Unit
			Min ^b	Typ ^a	Max ^b	
Input						
T _X Input Voltage High	V _{INH}		4			V
T _X Input Voltage Low	V _{INL}				1	
T _X Input Current Low	I _{IL}	T _X = 0 V	-50		-2.0	μA
T _X Input Current High	I _{IH}	T _X = V _{DD}	-1.0		1.0	
Output						
Bus Recessive	V _{CAN_HR} , V _{CAN_LR}	T _X = V _{INH} , R _L = ∞	2	2.5	3	V
	V _{DIF} = V _{CAN_HR} - V _{CAN_LR}		-0.5	0	0.05	
Bus Dominant	V _{CAN_HD}	T _X = V _{INL} , R _L = 60 Ω	2.75	3.5	4.5	
	V _{CAN_LD}		0.5	1.5	2.25	
	V _{DIF} = V _{CAN_HD} - V _{CAN_LD}		1.5	2	3	
Reference Output	V _{REF}	-25 μA ≤ I _{REF} ≤ 25 μA	0.5 V _{DD} -0.2	0.5 V _{DD}	0.5 V _{DD} +0.2	
Receive Output (Bus Recessive Condi- tions)	V _{RXH}	T _X = V _{INH} -2.0 V ≤ V _{CAN_H} , V _{CAN_L} ≤ 7 V -1 V ≤ V _{CAN_H} - V _{CAN_L} ≤ 0.5 V (Bus Recessive)	I _{OUT} = -10 μA	V _{DD} -0.3	V _{DD} -0.05	
			I _{OUT} = -100 μA	V _{DD} -1	V _{DD} -0.2	
			I _{OUT} = -2 mA	V _{DD} -1.75	V _{DD} -1	
Receive Output (Bus Dominant Conditions)	V _{RXL}	T _X = V _{INH} -0.8 V ≤ V _{CAN_H} ≤ 7 V -2 V ≤ V _{CAN_L} ≤ 5.8 V 0.9 V ≤ V _{CAN_H} - V _{CAN_L} ≤ 5 V (Bus Dominant)	I _{OUT} = 10 μA		0.05	0.3
			I _{OUT} = 100 μA		0.2	1
			I _{OUT} = 2 mA		1	1.75
Internal Resistance from Bus Pins	R _{IN} , BUS_L	T _X = V _{INH} (Recessive)	5		50	kΩ
	R _{IN} , BUS_H		5		50	
	R _{DIFF}		10		100	
Internal Capacitance from Bus Pins ^c	C _{IN} (CAN_H, CAN_L)				50	pF



SPECIFICATIONS						
Parameter	Symbol	Test Conditions Unless Otherwise Specified $V_{DD} = 4.75$ to 5.25 V	Limits $T_A = -40$ to 125°C			Unit
			Min ^b	Typ ^a	Max ^b	
Dynamic						
Propagation Delay – TX to V_{DIFF} High	t_{ON-TX}				50	ns
Propagation Delay – TX to V_{DIFF} Low	t_{OFF-TX}				50	
Propagation Delay – TX to Receive Low	t_{ON-RX}				120	
Propagation Delay – TX to Receive High	t_{OFF-RX}				120	
Supply						
Supply Current	I_{DD}	$\overline{TX} = V_{INH}, V_{DD} = 5.25$ V, $R_L = 60$ Ω (Recessive)			25	mA
		$\overline{TX} = V_{INL}, V_{DD} = 5.25$ V, $R_L = 60$ Ω (Dominant)	40		75	
Transient^c						
Electrostatic Discharge Human Body Model	V_{ESD}	$C_L = 100$ pF, $R_L = 1500$ Ω MIL-STD-883D, Method 3015		2000		V
Bus Transient Voltage	V_{TRANS}	$R_S = 1000$ Ω , 1 msec	-60		60	
Protection						
Thermal Trip Point ^c	T_{TRP}		150	165	180	$^\circ\text{C}$
Thermal Hysteresis ^c	T_{HYS}		10	20	30	

Notes

- a. Typical values are for DESIGN AID ONLY at $T_A = 25^\circ\text{C}$, not guaranteed nor subject to production testing.
- b. The algebraic convention whereby the most negative value is a minimum and the most positive a maximum.
- c. Guaranteed by design, not subject to production test.

TRUTH TABLE					
\overline{TX}	Mode	Bus State	CAN_H	CAN_L	RX
Low	Transmit	Dominant	High	Low	Low
High (or Floating)	Transmit and Receive	Recessive	Floating	Floating	High
High (or Floating)	Receive	Recessive	High	Low	Low

SWITCHING TIME TEST CIRCUIT

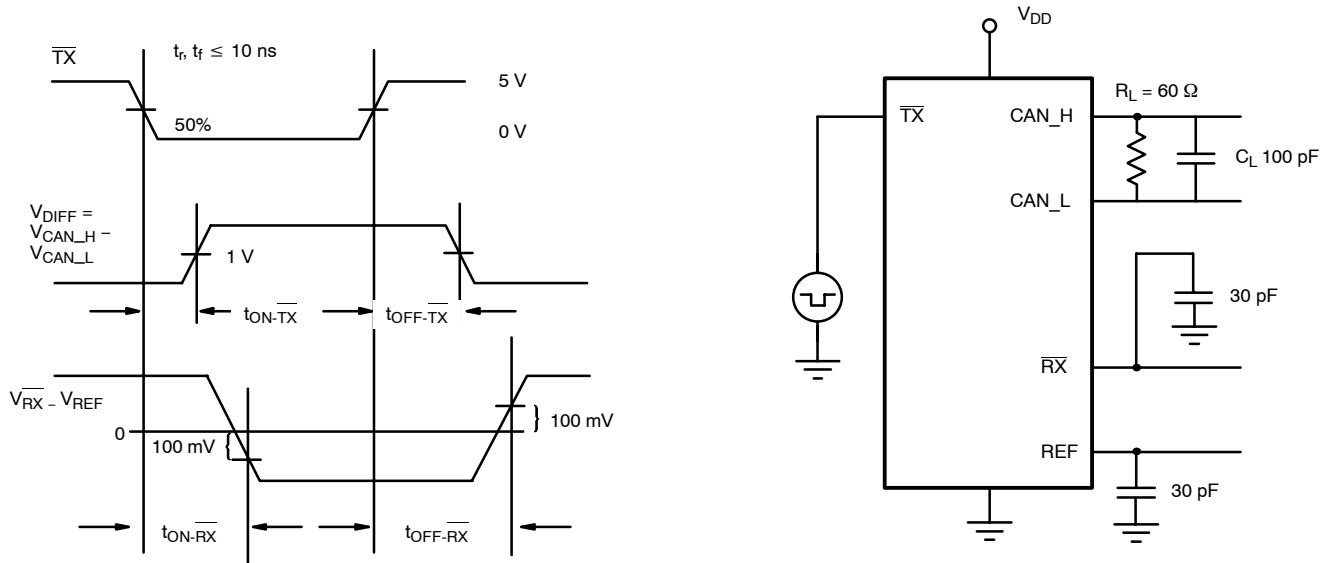

CIRCUIT SCHEMATIC

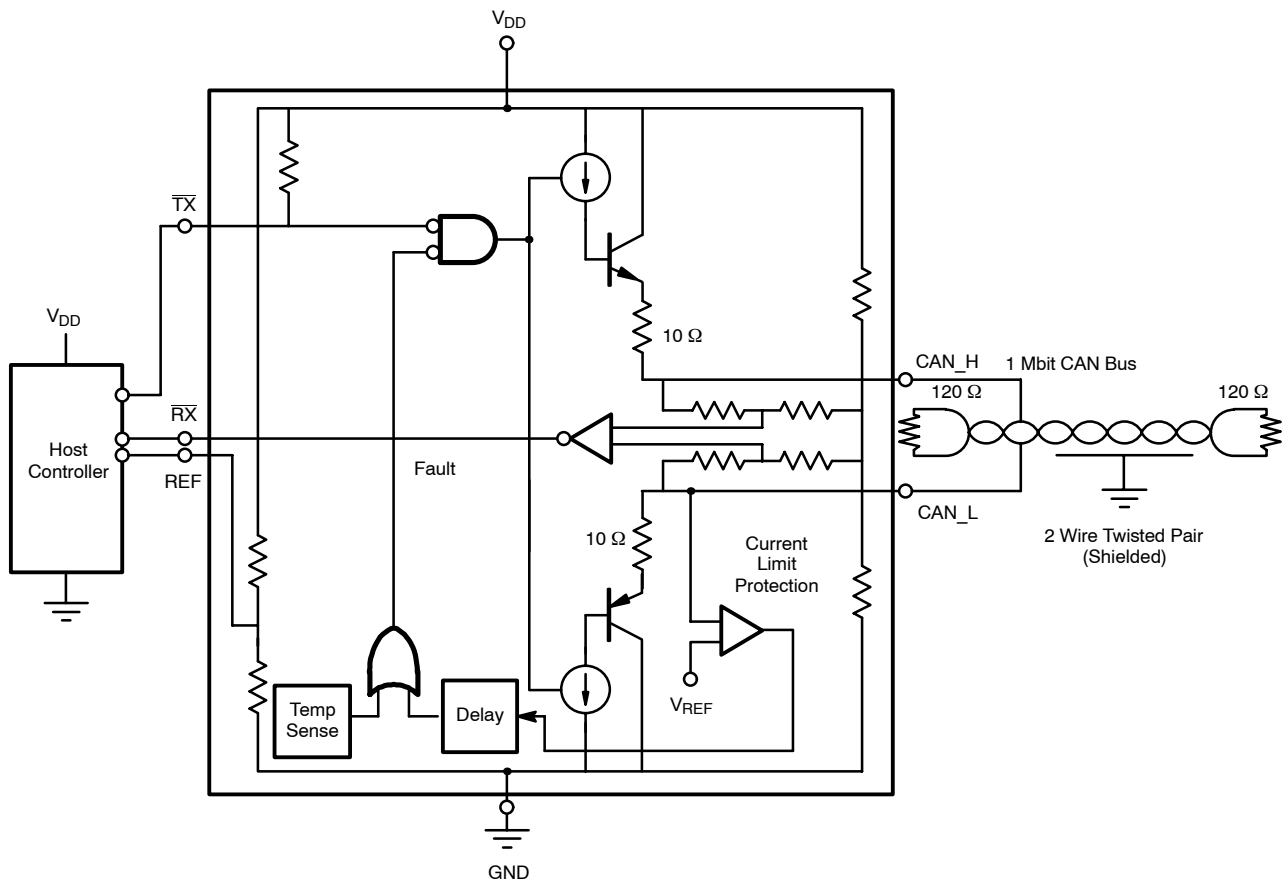



Notice

Specifications of the products displayed herein are subject to change without notice. Vishay Intertechnology, Inc., or anyone on its behalf, assumes no responsibility or liability for any errors or inaccuracies.

Information contained herein is intended to provide a product description only. No license, express or implied, by estoppel or otherwise, to any intellectual property rights is granted by this document. Except as provided in Vishay's terms and conditions of sale for such products, Vishay assumes no liability whatsoever, and disclaims any express or implied warranty, relating to sale and/or use of Vishay products including liability or warranties relating to fitness for a particular purpose, merchantability, or infringement of any patent, copyright, or other intellectual property right.

The products shown herein are not designed for use in medical, life-saving, or life-sustaining applications. Customers using or selling these products for use in such applications do so at their own risk and agree to fully indemnify Vishay for any damages resulting from such improper use or sale.