

**Features and Benefits**

Wall-Mount Racks are ideal for smaller installations and can be stacked for future expansion. Available in shallow, deep and ultra-deep mount, all racks are hinged for easy access to the back of mounted equipment. Racks can be installed using toggle bolts or wall anchors.

- Stackable for future growth
- Hinged for easy equipment access
- Variety of position sizes available

**Material**

Black Powdercoat 13 Gauge Cold Rolled Steel

**Reference Information**

Parts List

- Wall-Mount Rack
- Mounting Screws
- Assembly Instructions

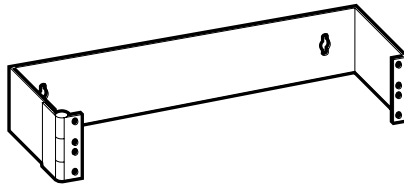

**2U Shallow Wall-Mount Rack**  
 Dimensions: 89mm x 495mm x 102mm  
 (3.5"H x 19.5"W x 4"D)  
 Shipping Weight: 1.4kg (3 lb.)

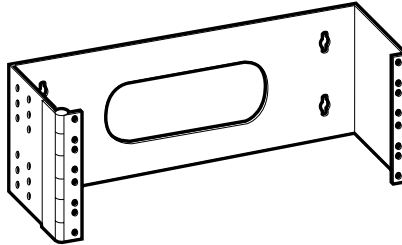

**4U Shallow Wall-Mount Rack**  
 Dimensions: 178mm x 495mm x 102mm  
 (7"H x 19.5"W x 4"D)  
 Shipping Weight: 2.3kg (5 lb.)

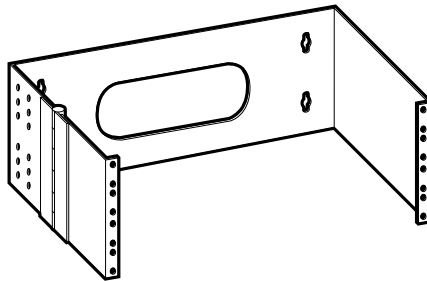

**4U Deep Wall-Mount Rack**  
 Dimensions: 178mm x 489mm x 203mm  
 (7"H x 19.25"W x 8"D)  
 Shipping Weight: 2.3kg (5 lb.)

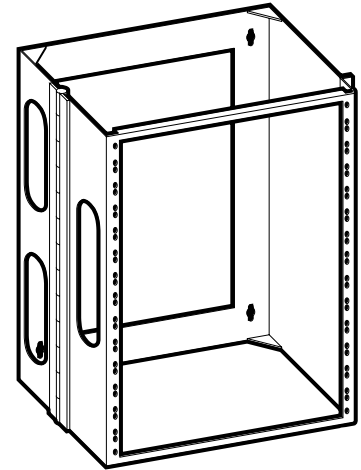

**14U Deep Wall-Mount Rack**  
 Dimensions: 648mm x 489mm x 203mm  
 (25.5"H x 19.25"W x 8"D)  
 Shipping Weight: 12.7kg (28 lb.)

**ORDERING INFORMATION**

Order No.	Description
27-300	2U Shallow Wall-Mount Rack
25-104	4U Shallow Wall-Mount Rack
25-1D-04	4U Deep Wall-Mount Rack
25-1D-14	14U Deep Wall-Mount Rack

**MOLEX PREMISE NETWORKS**

Molex Premise Networks  
 Corporate Headquarters  
 New Hampshire, USA  
 Tel: 1 603 324 0200  
 www.molexpn.com

European Headquarters  
 Hampshire, England  
 Tel: 44 (0) 1489 527111  
 www.molexpn.co.uk

Pac Rim Headquarters  
 Victoria, Australia  
 Tel: 61 3 9971 7111  
 www.molexpn.com.au